

# OPERATOR'S MANUAL

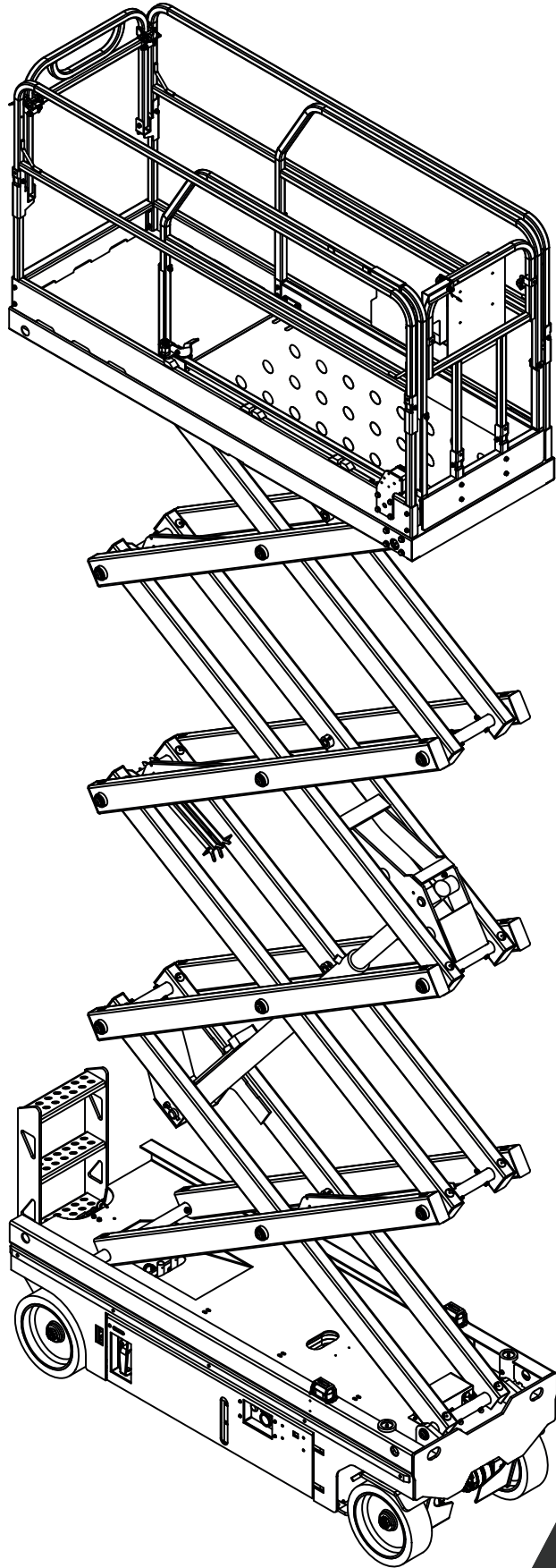

1930ED  
2632ED  
2646ED  
3346ED  
4046ED  
4646ED

# GMG

Global Machinery Group, Inc.

i.	Specifications.....	4
1.	Introduction.....	7
2.	Safety.....	9
2.1	Safety Alert Symbols.....	9
2.2	Fall Protection.....	10
2.3	Electrocution Hazard .....	10
2.4	Tip-over Hazards .....	11
2.5	Fall Hazards.....	12
2.6	Collision Hazards.....	12
2.7	Additional Safety Hazards .....	13
2.7.1	Explosion and Fire Hazards.....	13
2.7.2	Damaged Machine Hazards .....	13
2.7.3	Bodily Injury Hazards.....	13
2.7.4	Weld Line to Platform Safety (if equipped) .....	13
2.7.5	Battery Safety .....	13
3.	Controls & Components.....	15
3.1	Component Locations.....	15
3.2	Platform Controls.....	16
3.3	Lower Controls.....	19
4.	Workplace Inspection .....	21
4.1	Workplace Inspection .....	21
5.	Operating Instructions & Function Tests.....	23
5.1	Prestart.....	23
5.1.1	Functions Test.....	23
5.1.2	At the Lower Controls .....	23
5.1.3	Test Emergency Stop.....	23
5.1.4	Test Up/Down Functions.....	24
5.1.5	Test the Emergency Lowering .....	24
5.1.6	At the Platform Controls.....	24
5.1.7	Test EMERGENCY STOP .....	24
5.1.8	Test the Horn .....	24
5.2	Test Function Enable and Up/Down Functions.....	25
5.3	Test the Steering.....	26
5.4	Test Drive and Braking.....	26
5.5	Test Limited Drive Speed.....	27

6.	Operating Instructions.....	29
6.1	EMERGENCY STOP.....	29
6.2	Emergency Lowering.....	29
6.3	Operation from Lower Controls.....	30
6.4	Operation from Platform Controls.....	30
6.4.1	To Position Platform.....	30
6.4.2	To Steer.....	31
6.4.3	To Drive.....	32
6.4.4	To Reduce Drive Speed.....	33
6.5.1	Tilt reading.....	34
6.5.2	Overload indication.....	34
6.5.3	Battery status (only on type C control box).....	35
6.6	Driving On A Slope.....	35
6.7	To extend and retract the deck extension.....	36
6.8	Shutdown Procedure.....	36
8.	Battery Charging.....	37
9.	Maintenance.....	39
9.1	Routine Maintenance.....	40
9.2	Pre-Start Inspection.....	40
9.3	Frequent and Annual Maintenance.....	40
9.4	Lubrication.....	41
9.5	Maintenance Lock.....	42
10.	Inspections.....	43
10.1	pre-start inspection.....	43
10.2	Frequent Inspection Checklist.....	44
10.3	Annual Inspection Report.....	45
11.	Transport and Lifting Instructions.....	47
11.1	Safety Information.....	47
11.2	Free-wheel configuration for Winching or Towing.....	47
11.2.1	Driving or Winching onto or off of a Transport Vehicle.....	48
11.2.2	Securing to Truck or Trailer for Transport.....	48
11.3	Lifting Instructions.....	49

## I. SPECIFICATIONS

	1930ED	2632ED	2646ED
--	--------	--------	--------

### HEIGHTS

Working Height	7,80 m	10,00 m	10,00 m
Platform Height	5,80 m	8,00 m	8,00 m
Stowed:			
Guardrails up	2,16 m	2,29 m	2,25 m
Guardrails folded	1,79 m	1,80 m	1,69 m
Platform floor	1,03 m	1,17 m	1,04 m
Guardrail	1,10 m	1,10 m	1,10 m
Toeboard height	0,15 m	0,15 m	0,15 m

### DIMENSIONS

Length			
Stowed	1,82 m	2,45 m	2,46 m
With step removed	1,66 m	2,26 m	2,32 m
Width	0,76 m	0,80 m	1,17 m
Ground clearance	5 cm	10 cm	10 cm
Platform length			
Extended	2,55 m	3,24 m	3,32 m
Retracted	1,64 m	2,25 m	2,31 m
Platform width	0,74 m	0,80 m	1,15 m

### PERFORMANCE - GENERAL SPECIFICATIONS

Platform lift capacity	230 kg	230 kg	450 kg
Extension deck capacity	120 kg	120 kg	120 kg
Turning radius - outside	1,56 m	1,74 m	2,00 m
Power source	Batteries 24V/ 224 Ah		
Drive system	Direct Electric Drive		
Drive speed			
Stowed	4,02 km/h 0,70 km/h		
Elevated			
Wheel size	14 x 4,5 inch	16 x 5 inch	
Gradeability	30 %	25 %	
Brakes	Multiple disc		
Weight	1490 kg	2000 kg	2535 kg
Max allowable drive height	5,80 m	8,00 m	8,00 m
Max. allowable wind speed	0 m/s	0 m/s	12,5 m/s

## II. SPECIFICATIONS

**3346ED**
**4046ED**
**4646ED**

### HEIGHTS

Working Height	12,00 m	13,90 m	15,90 m
Platform Height	10,00 m	11,89 m	13,90 m
Stowed:			
Guardrails up	2,44 m	2,55 m	2,69 m
Guardrails folded	1,76 m	1,88 m	2,00 m
Platform floor	1,31 m	1,34 m	1,60 m
Guardrail	1,10 m	1,10 m	1,10 m
Toeboard height	0,17 m	0,17 m	0,17 m

### DIMENSIONS

Length			
Stowed	2,46 m	2,46 m	2,46 m
With step removed	2,32 m	2,32 m	2,32 m
Width	1,17 m	1,17 m	1,17 m
Ground clearance	10 cm	10 cm	10 cm
Platform length			
Extended	3,32 m	3,32 m	3,32 m
Retracted	2,31 m	2,31 m	2,31 m
Platform width	1,15 m	1,15 m	1,15 m

### PERFORMANCE - GENERAL SPECIFICATIONS

Platform lift capacity	350 kg	350 kg	230 kg
Extension deck capacity	120 kg	120 kg	120 kg
Turning radius - outside	2,00 m	2,00 m	2,00 m
Power source	Direct electric drive		
Drive system	24v, 225 Ah batteries		
Drive speed			
Stowed	3,8 km/h	3,8 km/h	3,4 km/h
Elevated	0,7 km/h		
Wheel size	16 x 5 inch		
Gradeability	25 %		
Brakes	Multiple disc		
Weight	2950 kg	3225 kg	3400 kg
Max allowable drive height	10,00 m	11,89 m	10,00 m
Max. allowable wind speed	12,5 m/s	0 m/s	0m/s

# GMG 1930ED - 4646ED

Operator's manual

## 1. INTRODUCTION

---

This Operator's Manual has been designed to provide you, the owner, user or operator, with the instructions and operating procedures essential to properly and safely operate your GMG Aerial Work Platform for positioning personnel, along with their necessary tools and materials, to overhead work locations.



**The Operator's Manual must be read and understood prior to operating your GMG Aerial Work Platform. The user/operator should not accept operating responsibility until he/she has read and understands the operator's manual as well as having operated the GMG Aerial Work Platform under supervision of unauthorized, trained and qualified operator.**

**It is essential that the operator of the aerial work platform is not alone on the workplace during operation.**

**Modifications of this machine from the original design and specifications without written permission from GMG are strictly forbidden. A modification may compromise the safety of the machine, subjecting operator(s) to serious injury or death.**



Your GMG Aerial Work Platform has been designed, built, and tested to provide safe, dependable service. Only authorized, trained and qualified personnel shall be allowed to operate or service the machine.

GMG, as manufacturer, has no direct control over machine application and operation. Proper safety practices are the responsibility of the owner, user and operator.

If there is a question on application and/or operation contact:

### Global Machinery Group

**USA Office:**

Global Machinery Group, Inc.  
3428 Bullock Lane  
San Luis Obispo, CA 93401  
USA  
Phone: +1.805.303.2066

**Eruope Office:**

GMG Europe  
Leemidden 21  
2678ME DE LIER  
The NETHERLANDS  
Phone: + 31 174 52 59 90

[www.goGMG.com](http://www.goGMG.com)

# GMG 1930ED - 4646ED

Operator's manual



## 2. SAFETY

---

**DO NOT** operate this machine until you have read and understood this manual, have performed the Workplace Inspection, Pre-Start Inspection and Routine Maintenance, and have completed all the test operations detailed in the Operating Instructions section.

Failure to read, understand and follow all safety rules, warnings, and instructions could result in serious injury or death. For your safety and the safety of those around you, you must operate your machine as instructed in this manual.

GMG designs aerial work platforms to safely and reliably position personnel, along with their necessary tools and materials, at overhead work locations. The owner/user/operator of the machine should not accept responsibility for the operation of the machine unless properly trained.

### 2.1 SAFETY ALERT SYMBOLS

---

GMG manuals use symbols and colours to help you recognize important safety, operation and maintenance information:



**RED** - Indicates an imminently hazardous situation which, if not avoided, will result in death or serious injury.



**ORANGE** - Indicates a potentially hazardous situation which, if not avoided, could result in death or serious injury.



**YELLOW** with alert symbol – Indicates a potentially hazardous situation which, if not avoided, may result in minor or moderate injury.

## 2.2 FALL PROTECTION

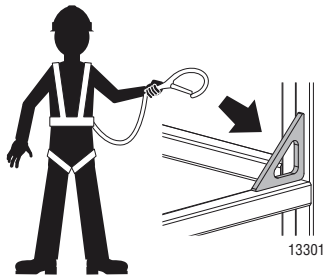

Operators must comply with employer, job site and governmental rules regarding the use of personal protective equipment.

If required by your employer or job site, use personal fall protection equipment (PFPE) when operating this machine.

All PFPE must comply with applicable governmental regulations, and must be inspected and used in accordance with the PFPE manufacturer's instructions.

Fall restraint must be properly attached to a designated anchorage point when driving or operating the machine. Attach only one fall restraint to each anchorage point.

## 2.3 ELECTROCUTION HAZARD



### ELECTROCUTION HAZARD! THIS MACHINE IS NOT INSULATED!

**DEATH OR SERIOUS INJURY will result from contact with or inadequate clearance from any electrically charged conductor.**

**You must maintain a CLEARANCE OF AT LEAST 3.05 m between any part of the machine, or its load, and any electrical line or apparatus carrying over 300 Volts up to 50,000 Volts. 30.5 cm additional clearance is required for every additional 30,000 Volts.**

#### Observe Minimum Safe Approach Distance.

This machine is not electrically insulated and will not provide protection from contact with or proximity to electrical current.

Maintain safe distances from electrical power lines and apparatus in accordance with applicable government regulations and the following chart:

#### Minimum safe distance voltage conductors

Voltage	
0 to 300 Volts	Avoid contact
Over 300V to 50kV	3,10 m
Over 50kV to 200kV	4,60 m
Over 200kV to 350 kV	6,10 m
Over 350kV to 500kV	7,60 m
Over 500kV to 750 kV	10,7 m
Over 750kV to 1000kV	13,7 m



Allow for platform movement, electrical line sway or sag and beware of strong or gusty winds.

Keep away from the machine if it contacts energized power lines. Personnel on the ground or in the platform must not touch or operate the machine until energized power lines are shut off.

Do not use the machine as a ground for welding.

## 2.4 TIP-OVER HAZARDS



13304  
**DO NOT OVERLOAD**

**DO NOT** exceed the maximum platform capacity. The weight of options and accessories will reduce the rated platform capacity and must be factored into the total platform load. Refer to the decals on the options.

**DO NOT** elevate the platform when the machine is on a surface that is soft and / or on a slope.

**DO NOT** depend on the tilt alarm as a level indicator. STOP if the tilt alarm sounds and the red light illuminates when the platform is raised. Use extreme caution to lower the platform. Move the machine to a firm, level surface.



13305  
**DO NOT DRIVE ON IRREGULAR OR UNSTABLE SURFACE**

Driving: **DO NOT** drive the machine on a slope that exceeds the maximum uphill or downhill slope rating. Slope rating applies to machines in the stowed position.

Driving in stowed position: use extreme care and reduce speed when driving across uneven terrain, debris, unstable or slippery surfaces, and near holes or drop-offs.

Driving with the platform elevated: **DO NOT** drive on or near uneven terrain, unstable surfaces, curbs, drop-offs or other hazardous conditions.



13306  
**DO NOT PUSH OR PULL OBJECTS OUTSIDE PLATFORM**

**DO NOT** push or pull toward any object outside the platform.  
**DO NOT** push the machine or other objects with the platform.  
**DO NOT** contact adjacent structures with the platform.

<p><b>Maximum Allowable Side Force</b> <b>200 Newton per person</b></p>
-----------------------------------------------------------------------------

**DO NOT** use the platform controls to free a platform that is caught, snagged or otherwise prevented from normal motion by an adjacent structure. For outdoor rated machines, **DO NOT** elevate the platform when wind speeds are in excess 12,5 m/s. If wind speeds exceed 12,5 m/s when the platform is elevated, carefully lower the platform and discontinue operation.

**DO NOT** increase the surface area of the platform (i.e. cover the rails with tarp or plywood). Increased surface area exposed to the wind will decrease machine stability.

**DO NOT** attach overhanging loads or use the machine as a crane.

**DO NOT** place loads outside the platform perimeter.

**NEVER** transport tools and materials unless they are firmly secured. Secure all tools and loose materials.

**NEVER** alter or disable any machine components.

**NEVER** replace any part of the machine with items of different weight or specification.

**NEVER** modify or alter the work platform without written permission from GMG.

**NEVER** place ladders or scaffolds in the platform or against any part of the machine.

**NEVER** use the machine on a moving or mobile surface or vehicle.

Ensure that all tires are in good condition and lug nuts are properly torqued.

**DO NOT** operate the machine with the chassis trays open.

**DO NOT** alter or disable the limit switches or machine components that in any way affect safety and stability.

**DO NOT** replace items critical to machine stability with items of different weight or specification. **DO NOT** modify or alter this machine without prior written permission from the manufacturer.

**DO NOT** use batteries that weigh less than the original equipment. Each battery must weigh 25 kg. The batteries must weigh a minimum of 50 kg.



13307  
**DO NOT ELEVATE IN WINDY CONDITIONS**



13308  
**DO NOT USE AS CRANE**

## 2.5 FALL HAZARDS



13309

**DO NOT CLIMB ON RAILS**

**DO NOT** sit, stand or climb on the platform guard rails. Maintain a firm footing on the platform floor at all times.

**DO NOT** exit the platform when elevated. Keep the platform floor clear of debris.

**DO NOT** fasten a fall restraint lanyard to an adjacent structure.

Ensure that all gates are properly closed and secured before operating the machine. Operators must comply with employer and job site rules and governmental regulations regarding the use of personal protective equipment.



13310

**DO NOT EXIT PLATFORM  
WHEN ELEVATED**

## 2.6 COLLISION HAZARDS



13311

Check for equipment, materials or other obstructions before moving.

Check for overhead obstructions before moving.

Check for crushing hazards when holding the platform rail before moving.

Be aware of limited sight distance and blind spots when driving or operating.

Be aware of extended platform position(s) when moving the machine.



13312

Reduce travel speed when moving the machine on slopes, when near personnel and obstacles, or when surface conditions are wet, slippery or otherwise limiting.

**DO NOT** operate in the path of any crane unless the controls of the crane have been locked out and/or precautions have been taken to prevent any possible collision.



13313

Stunt driving and horseplay are **PROHIBITED**.

Watch for personnel and obstructions below the platform when lowering the platform. Keep hands and limbs out of scissers.

Use common sense and planning when operating the machine with the controller from the ground. Maintain safe distances between the operator, the machine and fixed objects.

## 2.7 ADDITIONAL SAFETY HAZARDS

---

### 2.7.1 EXPLOSION AND FIRE HAZARDS

---

**DO NOT** operate the machine in hazardous locations or locations where potentially flammable or explosive gases or particles may be present.

### 2.7.2 DAMAGED MACHINE HAZARDS

---

Conduct a thorough prestart inspection of the machine and test all functions before each work shift to check for damage, malfunction and unauthorized modification. Tag and remove a damaged, malfunctioning or modified machine from service. **DO NOT** use a damaged, malfunctioning or modified machine.

Routine maintenance must be performed by the operator before each work shift. Scheduled maintenance must be performed by a qualified service technician at scheduled intervals. Tag and remove from service any machine that has not had scheduled preventative maintenance performed.

Check that all safety and instructional decals are in place and undamaged.  
Check that the operator's, safety and responsibilities manuals are present in the storage container located in the platform. All manuals must be complete, undamaged and readable.

### 2.7.3 BODILY INJURY HAZARDS

---

**DO NOT** operate the machine when there is a hydraulic fluid or air leak. Hydraulic fluid or air under pressure can penetrate and/or burn skin.

All compartments must remain closed and secure during machine operation. Improper contact with components under any cover will cause serious injury. Only trained maintenance personnel should access compartments. The operator should only access a compartment when performing prestart inspection.

### 2.7.4 WELD LINE TO PLATFORM SAFETY (IF EQUIPPED)

---

Read, understand and follow all warnings and instructions provided with the welding power unit.

**DO NOT** connect weld leads or cables unless the welding power unit is turned off at the platform controls.  
**DO NOT** operate unless the weld cables are properly connected.  
**DO NOT** connect the ground lead to the platform.

### 2.7.5 BATTERY SAFETY

---

#### Burn Hazards

Batteries contain acid. Always wear protective clothing and eye wear when working with batteries. Avoid spilling or contacting battery acid. Neutralize battery acid spills with baking soda and water.

#### Explosion Hazards

Keep sparks, flame and lighted tobacco away from batteries. Batteries emit explosive gas. Leave the battery tray open while charging to avoid gas buildup.

#### Electrocution Hazards

Avoid contact with electrical terminals.

# GMG 1930ED - 4646ED

Operator's manual

### 3. CONTROLS & COMPONENTS

#### 3.1 COMPONENT LOCATIONS

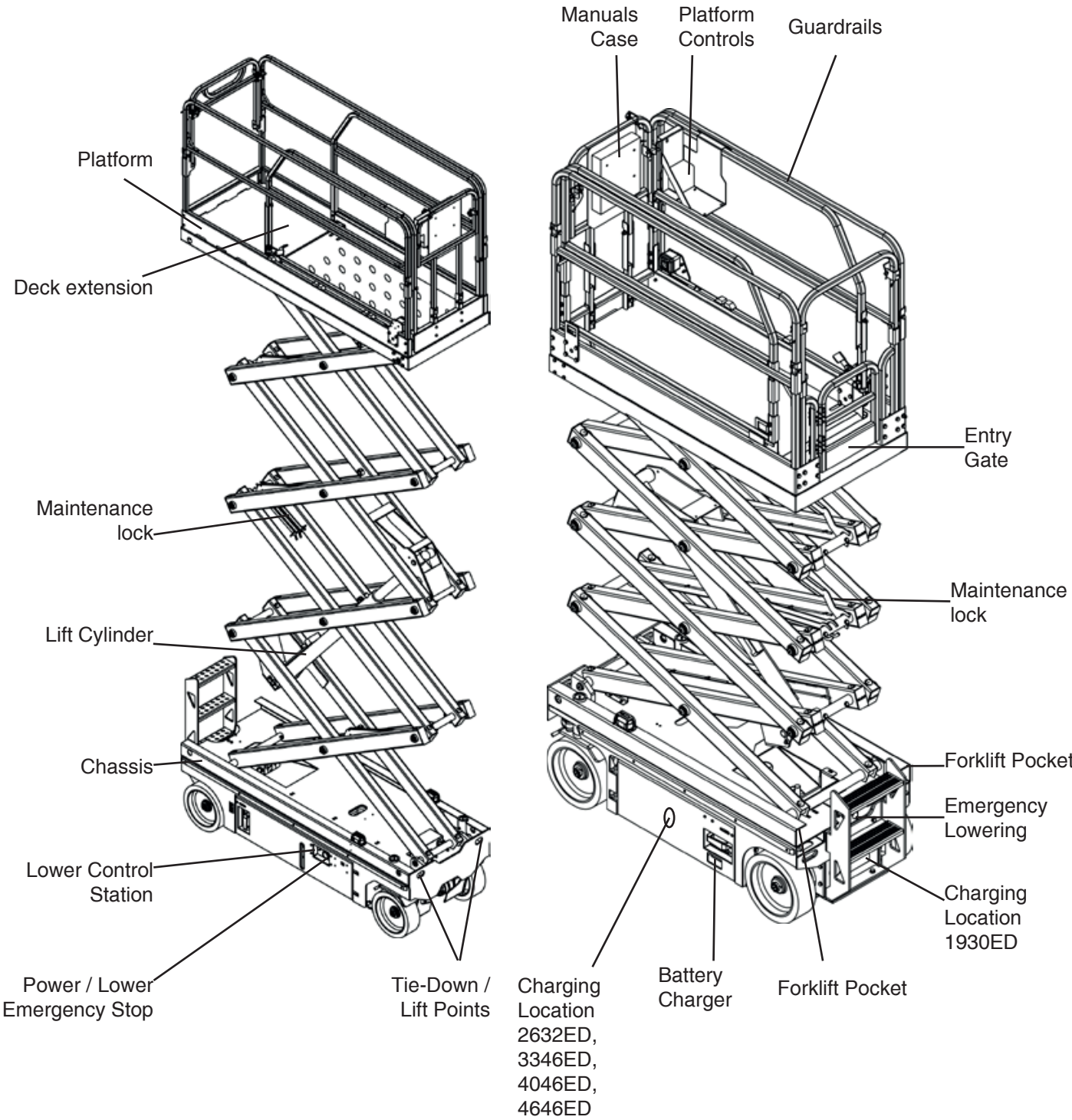

## 3.2.A PLATFORM CONTROLS (TYPE A)

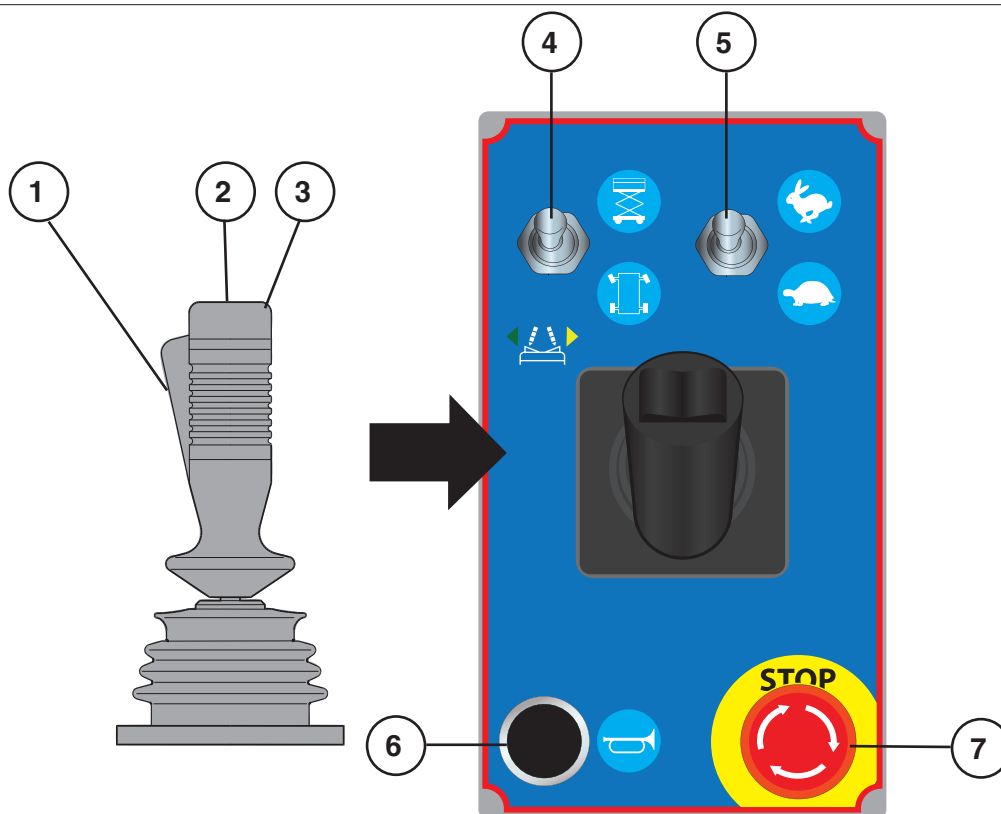

**! WARNING**

Be aware of the machine's position and of your surroundings before activating any control function.

Control	Description
1	Function Enable Switch Squeeze to enable DRIVE, STEER and LIFT functions from the Control Handle.
2	Steer Switch Using your thumb, press and hold the rocker switch to steer Left or Right.
3	Control Handle DRIVE - Proportionally controls Forward and Reverse Travel. LIFT - Proportionally controls Lift and Lower functions.
4	Lift/Drive Select Toggle this switch to the UP position for Lift function. Toggle this switch to the DOWN position for Drive function.
5	Drive Speed Select Switch in UP position (Rabbit symbol) indicates High Speed Drive is selected. Switch in DOWN position (Turtle symbol) indicates Low Speed Drive is selected.
6	Horn Button Press to sound warning horn.
7	Emergency Stop Press the EMERGENCY STOP at any time to stop all machine functions. Turn the switch clockwise to reset.



3.2.B PLATFORM CONTROLS (TYPE B)

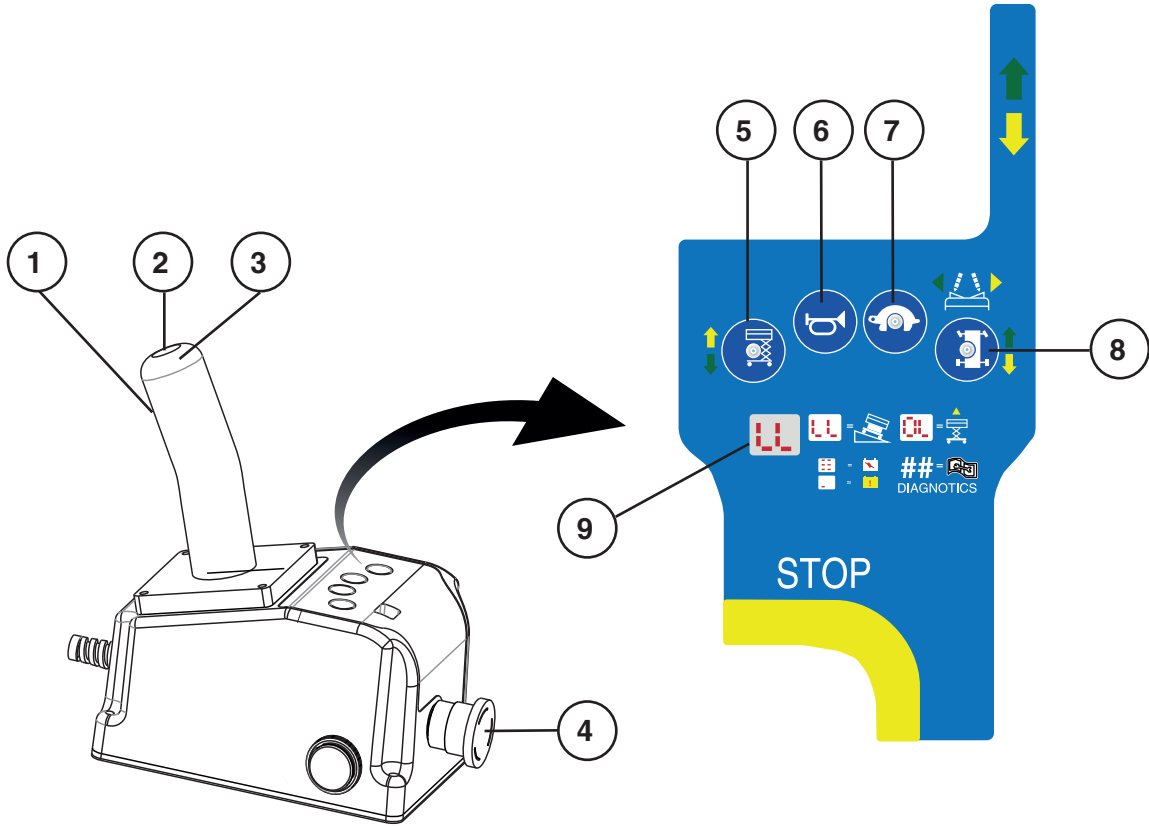

**! WARNING**

Be aware of the machine’s position and of your surroundings before activating any control function.

Control		Description
1	Function Enable Switch	Squeeze to enable DRIVE, STEER and LIFT functions from the Control Handle.
2	Steer Switch / thumb rocker	Using your thumb, press and hold the rocker switch to steer Left or Right.
3	Control Handle	DRIVE - Proportionally controls Forward and Reverse Travel. LIFT - Proportionally controls Lift and Lower functions.
4	Emergency Stop	Press the EMERGENCY STOP at any time to stop all machine functions. Turn switch clockwise to reset.
5	Lift Select	Press the button to enable the Lift function.
6	Horn Button	Press to sound warning horn.
7	Drive Speed Select	Light ON indicates Low Speed Drive is selected. Light OFF indicates High Speed Drive is selected.
8	Drive Select	Press this button to enable the Drive function.
9	Diagnostic display	Indicates the state of the battery charge and displays diagnostic codes when necessary.

## 3.2.C PLATFORM CONTROLS (TYPE C)

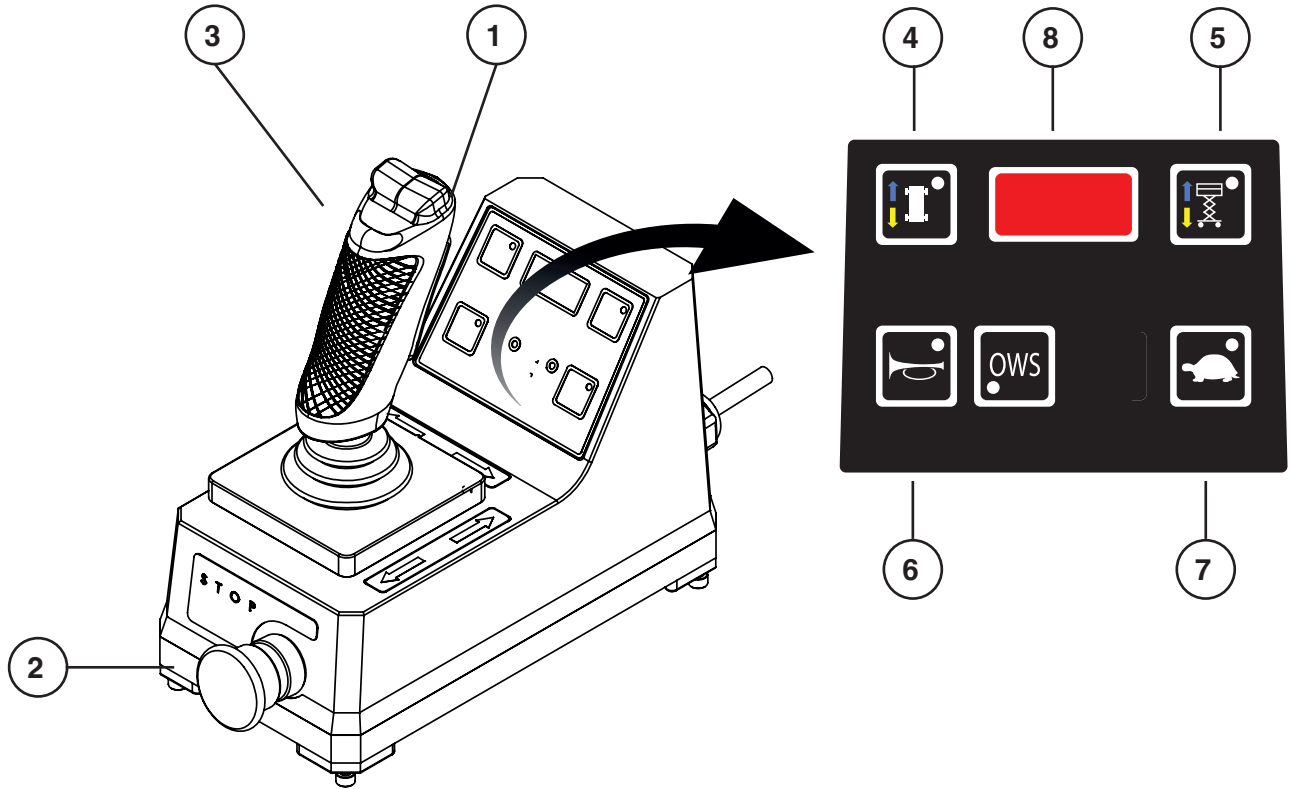

### WARNING

Be aware of the machine's position and of your surroundings before activating any control function.

Control	Description
1	Function Enable Switch Squeeze to enable DRIVE, STEER and LIFT functions from the Control Handle.
2	Emergency Stop Press the EMERGENCY STOP at any time to stop all machine functions. Turn switch clockwise to reset.
3	Control Handle DRIVE - Proportionally controls Forward and Reverse Travel. LIFT - Proportionally controls Lift and Lower functions. DECK - Proportionally controls deck movement - retract / extend
4	Drive Select Press this button to enable the Drive function.
5	Lift Select Press the button to enable the Lift function.
6	Horn Button Press to sound warning horn.
7	Drive Speed Select Light ON indicates slow Speed Drive is selected. Light OFF indicates high Speed Drive is selected.
8	Diagnostic display Indicates the state of the battery charge and displays diagnostic codes when necessary.

3.3 LOWER CONTROLS

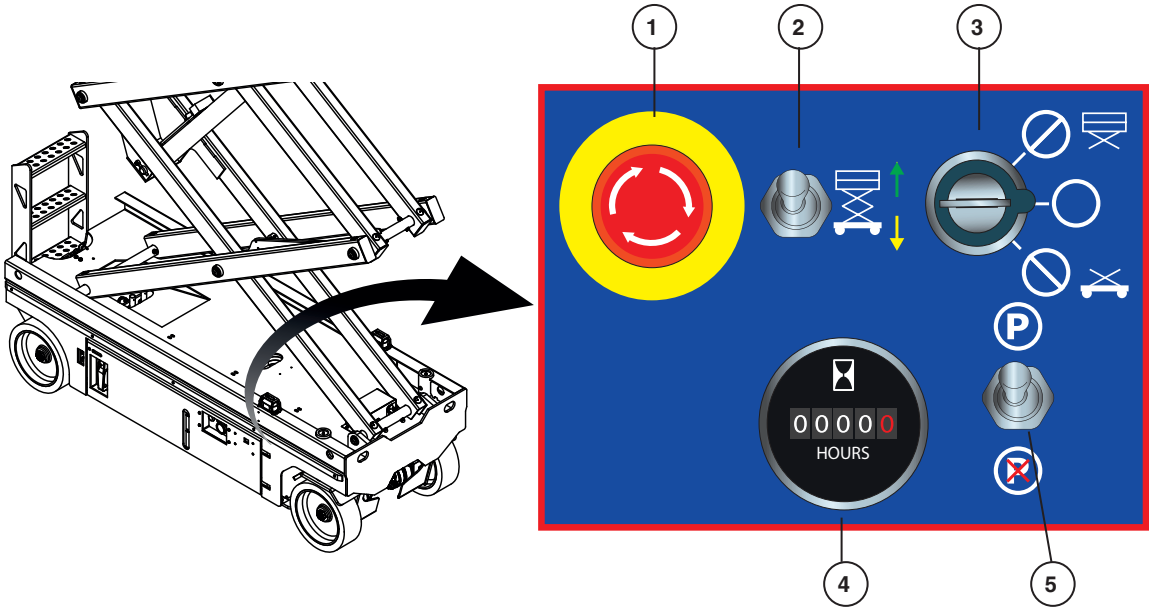

**WARNING**

Be aware of the machine’s position and of your surroundings before activating any control function.

Control		Description
1	Emergency Stop	Press the EMERGENCY STOP at any time to stop all machine functions. Turn switch clockwise to reset.
2	Platform Lift/Lower Switch	With the Key Switch in the LOWER position, move this switch up to lift the platform or down to lower the platform
3	Key Switch	PLATFORM - Select to operate from the PLATFORM control panel. LOWER - Select to operate from the LOWER control panel. OFF - Select to stop operation from either control panels.
4	Battery Indicator	Indicates the state of the battery charge
5	Brake Release Switch	Operate the brake release switch UP and hold to release brakes. Release the brake release switch after use. <b>DO NOT</b> operate the brake release switch if the machine is elevated or is on a sloped surface, or if there is an operator in the platform.

# GMG 1930ED - 4646ED

Operator's manual

## 4. WORKPLACE INSPECTION

---

**DO NOT** operate this machine until you have read and understood this manual, have performed the Workplace Inspection, Pre-Start Inspection and Routine Maintenance, and have completed all the test operations detailed in the Operating Instructions section.

Inspect the workplace and determine whether the workplace is suitable for safe machine operation. Do this before moving the machine to the workplace.

Be sure the lift is the correct machine for the job.

Be aware of workplace conditions, and continue to watch for hazards while operating the machine.

### 4.1 WORKPLACE INSPECTION

---

Before operating the machine, check the workplace for all possible hazards, including but not limited to:

- Drop-offs or holes, including those concealed by water, ice, mud, etc.
- Sloped, unstable or slippery surfaces
- Bumps, surface obstructions and debris
- Overhead obstructions and electrical conductors
- Other objects or equipment
- Hazardous locations and atmospheres
- Inadequate surface and support to withstand all load forces imposed by the machine
- Wind and weather conditions
- The presence of unauthorized personnel
- Other possible unsafe conditions

# GMG 1930ED - 4646ED

Operator's manual

## 5. OPERATING INSTRUCTIONS & FUNCTION TESTS

---

**DO NOT** operate this machine until you have read and understood this manual, have performed the Workplace Inspection, Prestart Inspection and Routine Maintenance, and have completed all the test operations detailed in the Operating Instructions section.

This section provides instructions and tests for each function of machine operation. Follow all safety rules and instructions. The operator must conduct inspections and a Functions Test of the machine before each work shift to check that all machine systems are working properly.

Test the machine on a firm level surface with no debris, drop-offs, potholes or overhead obstructions. Perform each step outlined in this section.

This machine shall only be operated by trained and authorized personnel. If multiple operators use this machine, all must be trained, qualified and authorized to use it. New operators must perform a Pre-Start Inspection and Functions Test prior to operating the machine.

Operators must comply with all employer and job site rules and governmental regulations regarding the use of personal protective equipment.

**DO NOT** use a machine that is malfunctioning. If any function does not perform as described, tag the machine and remove for repair by a qualified service technician.

### 5.1 PRESTART

---



- Perform *Prestart Inspection*.
- Check EMERGENCY STOP at both the lower and platform controls turn clockwise to reset.

#### 5.1.1 FUNCTIONS TEST

---

1. Select a test area that is firm, level and free of obstruction.
2. Be sure the battery pack is connected.

#### 5.1.2 AT THE LOWER CONTROLS

---

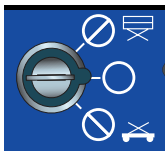

3. Turn the EMERGENCY STOP clockwise to set it to the ON position.
4. Set the KEY SWITCH at the lower controls at LOWER controls

#### 5.1.3 TEST EMERGENCY STOP

---



5. Push the EMERGENCY STOP to set it in the OFF position.
6. When EMERGENCY STOP is pressed in, all functions are disabled - flashing light should not lit.
7. Turn the EMERGENCY STOP clockwise to set it to the ON position.
8. When EMERGENCY STOP is set to ON - all functions are enabled - flashing light should blink.

## 5.1.4 TEST UP/DOWN FUNCTIONS

**WARNING** Check the area above and around the machine for obstructions and electrical power lines before operating the machine.

A buzzer with different sound frequency is controlled by the central system. The descent alarm sounds at 80 beeps per minute. The alarm that goes off when the machine is not level sounds at 200 beeps per minute.

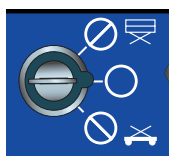

9. At the Lower Controls, turn the KEY SWITCH to OFF or PLATFORM position.
10. At the Lower Controls, push the button for ELEVATING/LOWERING the platform.. No function should operate.
11. Turn the KEY SWITCH to lower control position.

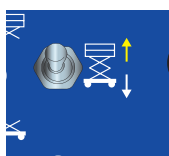

12. At the Lower Controls station, push up and hold the PLATFORM UP SWITCH. Platform should raise.
13. Push down and hold the PLATFORM DOWN SWITCH. The platform should lower to end. The descent alarm should sound while the platform is lowering.

## 5.1.5 TEST THE EMERGENCY LOWERING

Machine Rear View

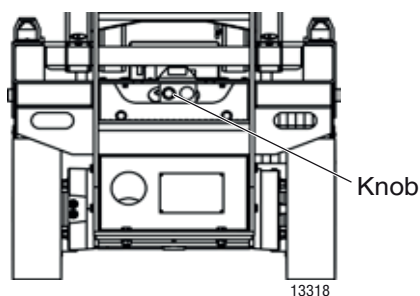

14. Activate the UP function and raise the platform approximately 60 cm.
15. Pull the EMERGENCY LOWERING. The platform should lower. The descent alarm will not sound.

## 5.1.6 AT THE PLATFORM CONTROLS

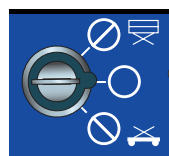

16. Turn the KEY SWITCH to platform control.

## 5.1.7 TEST EMERGENCY STOP



17. Push in the platform EMERGENCY STOP button to the off position. No functions should operate.
18. Pull or turn the EMERGENCY STOP button clockwise to the on position. The LED indicator light should come on.

## 5.1.8 TEST THE HORN



19. Push the HORN BUTTON. The horn should sound.



## 5.2.A TEST FUNCTION ENABLE AND UP/DOWN FUNCTIONS

**WARNING** Check the area above and around the machine for obstructions and electrical power lines before operating the machine.

Control handle forward



Control handle reverse

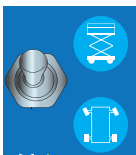
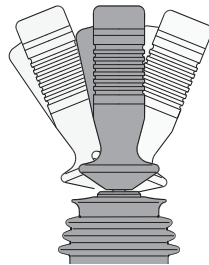

20. Toggle this switch to the UP position for Lift function.
21. Slowly move the CONTROL HANDLE forward and following reverse - not holding the Enable switch on the control handle.  
No functions should operate.
22. Press and hold the FUNCTION ENABLE SWITCH on the control handle.
23. Slowly move the CONTROL HANDLE reverse.  
The platform should raise. Releasing the control handle should stop the function.
24. Press and hold the FUNCTION ENABLE SWITCH. Slowly push the control handle forward.  
The platform should lower. The descent alarm should sound while the platform is lowering.

## 5.2.B TEST FUNCTION ENABLE AND UP/DOWN FUNCTIONS



20. Activate the Lift functions by pressing the LIFT-FUNCTION BUTTON.  
One pressed - the LED centred in this button will lit up.
21. Slowly move the CONTROL HANDLE forward and following reverse - not holding the Enable switch on the control handle.  
No functions should operate.
22. Press and hold the FUNCTION ENABLE SWITCH on the control handle.
23. Slowly move the CONTROL HANDLE reverse.  
The platform should raise. Releasing the control handle should stop the function.
24. Press and hold the FUNCTION ENABLE SWITCH. Slowly push the control handle forward.  
The platform should lower. The descent alarm should sound while the platform is lowering.

## 5.2.C TEST FUNCTION ENABLE AND UP/DOWN FUNCTIONS



20. Activate the Lift functions by pressing the LIFT-FUNCTION BUTTON.  
One pressed - the LED in this button will lit up.
21. Slowly move the CONTROL HANDLE forward and following reverse - not holding the Enable switch on the control handle.  
No functions should operate.
22. Press and hold the FUNCTION ENABLE SWITCH on the control handle.
23. Slowly move the CONTROL HANDLE reverse.  
The platform should raise. Releasing the control handle should stop the function.
24. Press and hold the FUNCTION ENABLE SWITCH. Slowly push the control handle forward.  
The platform should lower. The descent alarm should sound while the platform is lowering.

## 5.3.A TEST THE STEERING

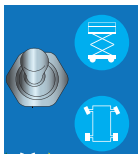

25. Toggle this switch to the DOWN position for Drive function.

26. Press and hold the FUNCTION ENABLE SWITCH on the control handle.

27. Depress the THUMB ROCKER SWITCH on top of the control handle in the direction identified by the green left arrow on the control panel. The steer wheels should turn in the direction that the green left arrow points on the control panel.



28. Depress the THUMB ROCKER SWITCH in the direction identified by the yellow right arrow on the control panel. The steer wheels should turn in the direction that the yellow right arrow points on the control panel.

## 5.3.B TEST THE STEERING



25. Activate the Drive functions by pressing the DRIVE-FUNCTION BUTTON. Once pressed - the LED centred in this button will lit up.

26. Press and hold the FUNCTION ENABLE SWITCH on the control handle.

27. Depress the THUMB ROCKER SWITCH on top of the control handle in the direction identified by the green left arrow on the control panel. The steer wheels should turn in the direction that the green left arrow points on the control panel.

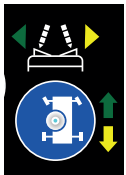

28. Depress the THUMB ROCKER SWITCH in the direction identified by the yellow right arrow on the control panel. The steer wheels should turn in the direction that the yellow right arrow points on the control panel.

## 5.3.C TEST THE STEERING



25. Activate the Drive functions by pressing the DRIVE-FUNCTION BUTTON. Once pressed - the LED in this button will lit up.

26. Press and hold the FUNCTION ENABLE SWITCH on the control handle.

27. Depress the THUMB ROCKER SWITCH on top of the control handle in the direction identified by the green left arrow on the control panel. The steer wheels should turn in the direction that the green left arrow points on the control panel.



28. Depress the THUMB ROCKER SWITCH in the direction identified by the yellow right arrow on the control panel. The steer wheels should turn in the direction that the yellow right arrow points on the control panel.

## 5.4 TEST DRIVE AND BRAKING

29. Press and hold the Function Enable Switch on the control handle.

30. Slowly move the control handle forward/downward until the machine begins to move, then return the handle to the center position.

The machine should move forward, in the direction of the steering wheels, then come to an abrupt stop.

31. Press and hold the Function Enable Switch on the control handle.

32. Slowly move the control handle rearward/upward until the machine begins to move, then return the handle to the center position.

The machine should move rearward, in the direction of the platform entry, then come to an abrupt stop.

**Note:** The brakes must be able to hold the machine on any slope it is able to climb.

## 5.5.A TEST LIMITED DRIVE SPEED

---

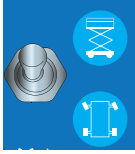

33. Toggle this switch to the UP position for Lift function.
  34. Press the FUNCTION ENABLE SWITCH. Raise the platform approximately 2 m from the ground.
  35. Toggle this switch to the DOWN position for Drive function.
  36. Press and hold the FUNCTION ENABLE SWITCH on the control handle.
  37. Slowly move the CONTROL HANDLE to the full drive position.  
The maximum achievable drive speed with the platform raised should not exceed 30.5 cm/s.
- If the drive speed with the platform raised exceeds 30.5 cm/s, immediately tag and remove the machine from service.

## 5.5.B TEST LIMITED DRIVE SPEED

---



33. Activate the Lift functions by pressing the LIFT-FUNCTION BUTTON.
34. Press the FUNCTION ENABLE SWITCH. Raise the platform approximately 2 m from the ground.



35. Activate the Drive functions by pressing the DRIVE-FUNCTION BUTTON.
  36. Press and hold the FUNCTION ENABLE SWITCH on the control handle.
  37. Slowly move the CONTROL HANDLE to the full drive position.  
The maximum achievable drive speed with the platform raised should not exceed 30.5 cm/s.
- If the drive speed with the platform raised exceeds 30.5 cm/s, immediately tag and remove the machine from service.

## 5.5.C TEST LIMITED DRIVE SPEED

---



33. Activate the Lift functions by pressing the LIFT-FUNCTION BUTTON.
34. Press the FUNCTION ENABLE SWITCH. Raise the platform approximately 2 m from the ground.

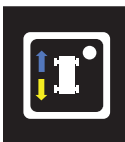

35. Activate the Drive functions by pressing the DRIVE-FUNCTION BUTTON.
  36. Press and hold the FUNCTION ENABLE SWITCH on the control handle.
  37. Slowly move the CONTROL HANDLE to the full drive position.  
The maximum achievable drive speed with the platform raised should not exceed 30.5 cm/s.
- If the drive speed with the platform raised exceeds 30.5 cm/s, immediately tag and remove the machine from service.

# GMG 1930ED - 4646ED

Operator's manual

## 6. OPERATING INSTRUCTIONS

---



### **WARNING**

Check the area above and around the machine for obstructions and electrical power lines before operating the machine.

### 6.1 EMERGENCY STOP

---



- Push in the EMERGENCY STOP to the OFF position at the lower controls or the platform controls to stop all machine functions.
- If any function operates when either EMERGENCY STOP is pushed in, repair the EMERGENCY STOP function before using the machine.

### 6.2 EMERGENCY LOWERING

---



### **WARNING**

If the control system fails while the platform is elevated, use the emergency lowering procedure to safely lower the platform.

**Do not climb down the scissor assembly or exit the platform.**

The Emergency Lowering System is used to lower the platform in case of power failure.

- Pull the Emergency Lowering Handle to lower the platform.

## 6.3 OPERATION FROM LOWER CONTROLS

**! WARNING** Check the area above and around the machine for obstructions and electrical power lines before operating the machine.

Drive and steer functions are not available from the LOWER CONTROLS.

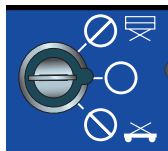

1. Turn the KEY SWITCH to LOWER CONTROLS.
2. Set the EMERGENCY STOP to the ON position at both the lower and platform controls.



3. Be sure the battery pack is connected before operating the machine.

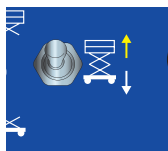

4. Move the UP/DOWN TOGGLE SWITCH according to the markings on the control panel.

## 6.4 OPERATION FROM PLATFORM CONTROLS

**! WARNING** Check the area above and around the machine for obstructions and electrical power lines before operating the machine.

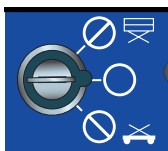

1. Turn the KEY SWITCH to PLATFORM CONTROLS.
2. Set the EMERGENCY STOP to the ON position at both the lower and platform controls.
3. Be sure the battery pack is connected before operating the machine.

### 6.4.1.A To POSITION PLATFORM

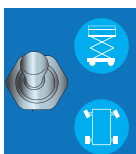

1. Toggle this switch to the UP position for Lift function.
2. Press and hold the FUNCTION ENABLE SWITCH on the CONTROL HANDLE.
3. Pull the CONTROL HANDLE forward/reverse to raise the platform.
4. Push the CONTROL HANDLE forward/reverse to lower the platform



### 6.4.1.B To POSITION PLATFORM



1. Activate the Lifting-functions by pressing the LIFT-FUNCTION BUTTON.
2. Press and hold the FUNCTION ENABLE SWITCH on the CONTROL HANDLE.
3. Pull the CONTROL HANDLE forward/reverse to raise the platform.
4. Push the CONTROL HANDLE forward/reverse to lower the platform

## 6.4.1.C To POSITION PLATFORM

---



1. Activate the Lifting-functions by pressing the LIFT-FUNCTION BUTTON.
2. Press and hold the FUNCTION ENABLE SWITCH on the CONTROL HANDLE.
3. Pull the CONTROL HANDLE forward/reverse to raise the platform.
4. Push the CONTROL HANDLE forward/reverse to lower the platform

## 6.4.2.A To STEER

---

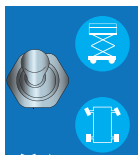

1. Toggle this switch to the DOWN position for Drive function.
2. Press and hold the FUNCTION ENABLE SWITCH on the CONTROL HANDLE.
3. Turn the steer wheels with the THUMB ROCKER SWITCH located on the top of the CONTROL HANDLE.

## 6.4.2.B To STEER

---



1. Activate the Drive-functions by pressing the DRIVE-FUNCTIONS BUTTON.
2. Press and hold the FUNCTION ENABLE SWITCH on the CONTROL HANDLE.
3. Turn the steer wheels with the THUMB ROCKER SWITCH located on the top of the CONTROL HANDLE.

## 6.4.2.C To STEER

---

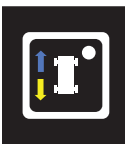

1. Activate the Drive-functions by pressing the DRIVE-FUNCTIONS BUTTON.
2. Press and hold the FUNCTION ENABLE SWITCH on the CONTROL HANDLE.
3. Turn the steer wheels with the THUMB ROCKER SWITCH located on the top of the CONTROL HANDLE.

## 6.4.3.A To DRIVE

---

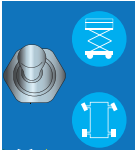

1. Toggle this switch to the DOWN position for Drive function.
2. Press and hold the FUNCTION ENABLE SWITCH on the CONTROL HANDLE.
  - Increase speed: Slowly move the control handle off center.
  - Push the CONTROL HANDLE forward to move forward. Pull the control handle reverse to move reverse.
  - Decrease speed: Slowly move the CONTROL HANDLE towards center.
  - Stop: Return the control handle to center or release the FUNCTION ENABLE SWITCH. Use the color-coded direction arrows on the platform controls to identify the direction the machine will travel.

Machine travel speed is restricted when the platform is raised.

Battery condition will affect machine performance. Machine drive speed and function speed will drop when the battery level indicator is flashing.

## 6.4.3.B To DRIVE

---



1. Activate the Drive-functions by pressing the DRIVE-FUNCTION BUTTON.
2. Press and hold the FUNCTION ENABLE SWITCH on the CONTROL HANDLE.
  - Increase speed: Slowly move the CONTROL HANDLE off center.
  - Push the CONTROL HANDLE forward to move forward. Pull the CONTROL HANDLE reverse to move reverse.
  - Decrease speed: Slowly move the CONTROL HANDLE toward center.
  - Stop: Return the control handle to center or release the FUNCTION ENABLE SWITCH. Use the color-coded direction arrows on the platform controls to identify the direction the machine will travel.

Machine travel speed is restricted when the platform is raised.

Battery condition will affect machine performance. Machine drive speed and function speed will drop when the battery level indicator is flashing.

## 6.4.3.C To DRIVE

---



1. Activate the Drive-functions by pressing the DRIVE-FUNCTION BUTTON.
2. Press and hold the FUNCTION ENABLE SWITCH on the CONTROL HANDLE.
  - Increase speed: Slowly move the CONTROL HANDLE off center.
  - Push the CONTROL HANDLE forward to move forward. Pull the CONTROL HANDLE reverse to move reverse.
  - Decrease speed: Slowly move the CONTROL HANDLE toward center.
  - Stop: Return the control handle to center or release the FUNCTION ENABLE SWITCH. Use the color-coded direction arrows on the platform controls to identify the direction the machine will travel.

Machine travel speed is restricted when the platform is raised.

Battery condition will affect machine performance. Machine drive speed and function speed will drop when the battery level indicator is flashing.



## 6.4.4.A To REDUCE DRIVE SPEED

---



The drive controls can operate in two different drive speed modes.

When the Drive Speed Switch is in the DOWN position and set to the Turtle icon, slow drive speed mode is active.

When the Drive Speed Switch is in the UP position and set to the Rabbit icon, fast drive speed mode is active.

## 6.4.4.B To REDUCE DRIVE SPEED

---



The drive controls can operate in two different drive speed modes.

When the Drive Speed Select button (turtle icon) is pushed in and the LED light is on, slow drive speed mode is active.

When the Drive Speed Select button (turtle icon) is not pushed in and the LED light is not on, fast drive speed mode is active.

## 6.4.4.C To REDUCE DRIVE SPEED

---



The drive controls can operate in two different drive speed modes.

When the Drive Speed Select button (turtle icon) is pushed in and the LED light is on, slow drive speed mode is active.

When the Drive Speed Select button (turtle icon) is not pushed in and the LED light is not on, high drive speed mode is active.

## 6.5.1.A TILT READING

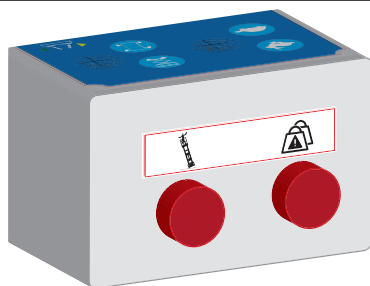

Front side upper control box - type A

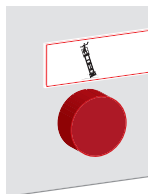

If the red light lit's up (left), the internal tilt sensors are detecting a TILT situation.

Further movements are being disabled, with the exception of lower the platform.

Lower the platform directly when the light lit's up. Position the machine of firm level ground.

## 6.5.2.A OVERLOAD INDICATION

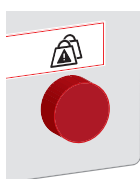

If the red light lit's up (right), the platform is overloaded.

No function will operate. An Alarm will sound.

1. Push in the EMERGENCY STOP to the OFF position
2. Remove weight from the platform.
3. Pull out the EMERGENCY STOP to the ON position

## 6.5.1.B TILT READING



If any of the DIAGNOSTIC DISPLAYS read out the message LL, the internal tilt sensors are detecting a TILT situation.

Further movements are being disabled, with the exception of lower the platform.

Lower the platform directly when the LL message is given. Position the machine of firm level ground.

## 6.5.2.B OVERLOAD INDICATION



If any of the DIAGNOSTIC DISPLAYS read out the message OL, the platform is overloaded.

No function will operate. An Alarm will sound.

1. Push in the EMERGENCY STOP to the OFF position
2. Remove weight from the platform.
3. Pull out the EMERGENCY STOP to the ON position

## 6.5.1.C TILT READING

If the DIAGNOSTIC DISPLAYS read out the message TLT the internal tilt sensors are detecting a TILT situation.

Further movements are being disabled, with the exception of lower the platform.

Lower the platform directly when the TLT message is given. Position the machine on firm level ground.

## 6.5.2.C OVERLOAD INDICATION

If any of the DIAGNOSTIC DISPLAYS read out the message OL, the platform is overloaded. No function will operate. An Alarm will sound.

1. Push in the EMERGENCY STOP to the OFF position
2. Remove weight from the platform.
3. Pull out the EMERGENCY STOP to the ON position

## 6.5.3.C BATTERY STATUS (ONLY ON TYPE C CONTROL BOX)

When none of the above is applied, display shows the status of the batteries. Where 100 is a full charge / 0 (zero) flat batteries.

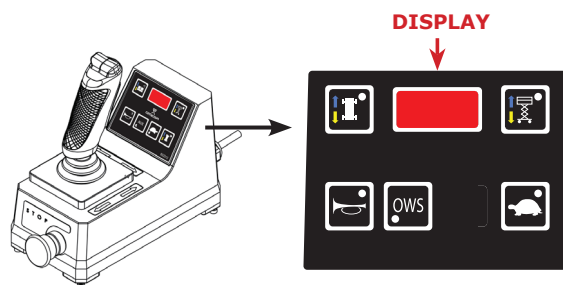

## 6.6 DRIVING ON A SLOPE

**WARNING** DO NOT drive the machine on a slope with the platform elevated. The platform must be in the fully stowed position before driving on a slope.

Determine the slope and side slope ratings for the machine and determine the slope grade.

Maximum forward/rearward slope rating, stowed position 25%.

Maximum side slope rating, stowed position 5°.

**Note:** Slope rating is subject to ground conditions and adequate traction.

Set the Drive Speed Switch to the DOWN (Turtle) position to engage slow speed drive mode.

## 6.7 To EXTEND AND RETRACT THE DECK EXTENSION

---

1 Press the Platform Lock Pin Foot Pedal on the extension deck.

2 Push the platform extension guardrail to extend the platform to the desired position.

**Do not** stand on the platform extension while extending or retracting it.

Platform Lock Pin  
Foot Pedal

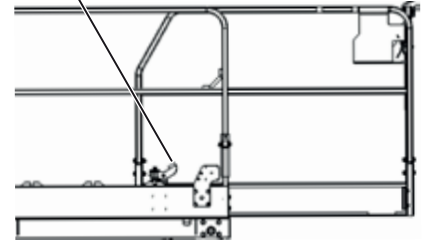

**! WARNING** IF THE ROLL-OUT DECK IS EXTENDED CHECK FOR CLEARANCE UNDER DECK AREA BEFORE LOWERING PLATFORM.

## 6.8 SHUTDOWN PROCEDURE

---

- When finished with the machine, place the platform in the stowed position.
- Park the machine on a level surface.
- Turn the Key Switch to the OFF position and remove the key to prevent unauthorized use. Carefully exit the platform using a constant three (3) point dismount/grip.
- Push in the red Main Power/Lower EMERGENCY STOP Switch button to the OFF position when leaving the machine at the end of the work day.
- Charge the batteries.

## 8. BATTERY CHARGING

### **WARNING**

The charger surface can get hot while operating. Contact with the skin or surrounding materials should be avoided.

To reduce the risk of an electric shock, connect only to a properly grounded single-phase (3 wire) outlet.

Do not use an external charger or booster battery.

Charge the battery in a well-ventilated area.

### **CAUTION**

Use proper AC input voltage for charging as indicated on the machine.  
Use only GMG authorized batteries and chargers.

**IMPORTANT**— Be sure to disconnect the charger from the outlet before attempting to operate the unit. The charger will indicate the status of the charge cycle.

1930-ED

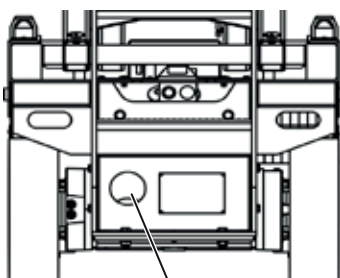

Battery Charge Location

2632-ED, 3346-ED,  
4046-ED, 4646-ED

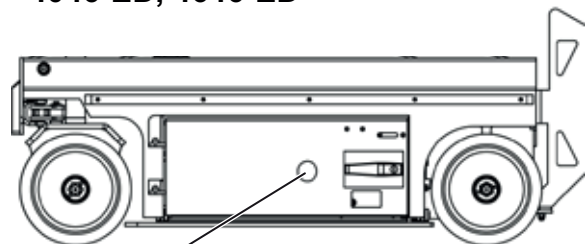

Battery Charge Location

# GMG 1930ED - 4646ED

Operator's manual

## 9. MAINTENANCE

---

**DO NOT** operate this machine until you have read and understood this manual, have performed the Workplace Inspection, Pre-Start Inspection and Routine Maintenance, and have completed all the test operations detailed in the Operating Instructions section.

The operator must conduct a Pre-Start Inspection of the machine and test all functions before each work shift to check for damage, malfunction and unauthorized modification. The inspection is designed to discover if anything is apparently wrong with a machine before the operator performs the function tests. Tag and remove a damaged, malfunctioning or modified machine from service.

**DO NOT** use a damaged, malfunctioning or modified machine.

Use the Pre-Start Inspection to determine what Routine Maintenance is required.

The operator may perform only the routine maintenance items specified in this manual.

**IMPORTANT**— Scheduled maintenance inspection checklists are included in this manual for use only by qualified service technicians. Only qualified service technicians may perform repairs to the machine. After repairs are completed, the operator must perform a Pre-Start Inspection before proceeding to the Functions Test.



**Hydraulic fluid under pressure can penetrate and burn skin, damage eyes, and may cause serious injury, blindness, and death. Repair leaks immediately. Fluid leaks under pressure may not always be visible. Check for pin hole leaks with a piece of cardboard, not your hand.**



**NEVER** perform work or inspection on the machine with the platform elevated without first blocking the scissor assembly with the Maintenance Lock.

**Perform scheduled maintenance at recommended intervals. Failure to perform scheduled maintenance at recommended intervals may result in a defective or malfunctioning machine and may result in injury or death of the operator. Keep maintenance records current and accurate. Immediately report any damage, defect, unauthorized modification or malfunction to your supervisor. Any defect must be repaired prior to continued use.**

**DO NOT** use a damaged, modified or malfunctioning machine.



**Never leave hydraulic components or hoses open. Plug all hoses and fitting immediately after disassembly to protect the system from outside contamination (including rain). Never open a hydraulic system when there are contaminants in the air. Always clean the surrounding area before opening hydraulic systems. Use only recommended lubricants. Improper lubricants or incompatible lubricants may cause as much damage as no lubrication. Watch for makeshift “fixes” which can jeopardize safety as well as lead to more costly repair. Inspection and maintenance should be performed by qualified personnel familiar with the equipment.**

## 9.1 ROUTINE MAINTENANCE

---



### **WARNING**

**NEVER** perform work or inspection on the machine with the platform elevated without first blocking the scissor assembly with the Maintenance Lock.

**IMPORTANT**—The operator may perform only maintenance items on the Pre-Start Inspection Checklist. Frequent and Annual maintenance must be performed by qualified service technicians.

## 9.2 PRE-START INSPECTION

---

Perform routine maintenance as identified in the *Pre-Start Inspection Checklist*.

## 9.3 FREQUENT AND ANNUAL MAINTENANCE

---

Frequent Inspection Checklists and Annual Inspection Reports must be completed by qualified service technicians trained and authorized to perform maintenance on this machine, and must be done in accordance with the procedures outlined in the service manual. Scheduled maintenance inspection checklists are included in this manual for use by qualified service technicians.

Machines that have been out of service for more than three months must have the Frequent Inspection Checklists completed before returning to service.

**IMPORTANT**— In addition to the Frequent Inspection Checklists and Annual Inspection, the 30-Day Service must be performed after the first 30 days or 40 hours of initial service. See the Service & Parts Manual for specific instructions.



## 9.4 LUBRICATION

Operator may perform routine maintenance only. Lubrication listed as Scheduled Maintenance must be performed by a qualified service technician.

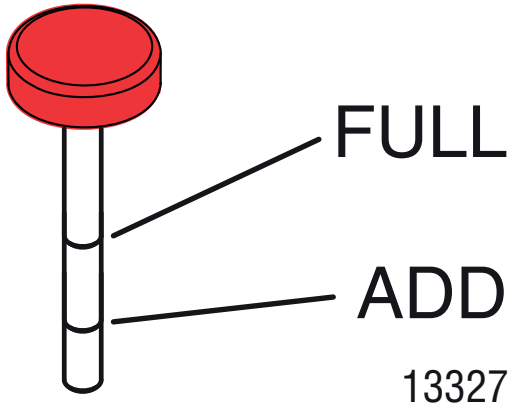

### 9.4.1 LUBRICATION

NO	ITEM	SPECIFICATION	FREQUENCY
1	Hydraulic Reservoir	<p>Mobile Fluid DTE 10, DTE 13M or AW32.</p> <p>Do not substitute other fluids as pump damage may result.</p> <p>Fill to the middle of the dipstick with platform in the stowed position.</p>	<p><b>Routine Maintenance</b> Check level daily Scheduled</p> <p><b>Maintenance Change</b> yearly or every 600 hours, whichever occurs first.</p>
2	Hydraulic Cap Breather Filter Hydraulic Filter	<p>Breather Filter (located inside filler cap)</p> <p>Hydraulic Filter Canister</p>	<p>Scheduled Maintenance</p> <p>Normal Conditions Change every six months or 300 hours, whichever occurs first</p> <p>Severe Conditions --very dusty, exceptionally hot or exceptionally cold conditions Change every three months or 150 hours, whichever occurs first</p>

## 9.5 MAINTENANCE LOCK



### WARNING

#### DEATH OR SERIOUS INJURY HAZARD!

**NEVER** perform work or inspection on the machine with the platform elevated without first blocking the scissor assembly with the Maintenance Lock. On machines equipped with two Maintenance Locks, **BOTH** must be set to safely work on or inspect the machine. **BOTH** Maintenance Locks must be stowed before lowering the platform.

**DO NOT** attempt to lower the platform with one maintenance lock in place. **DO NOT** engage the Maintenance Locks unless the platform is empty of tools and material.

- 1 Raise the platform approximately 2.2m from the ground
- 2 Rotate the Maintenance Lock(s) and allow it/them to hang straight down.
- 3 Lower the platform until the Maintenance Lock(s) rests securely on the link.

Keep clear of the Maintenance Lock when lowering the platform.

Stow the Maintenance locks by raising the platform slightly and rotating them to the stowed position.

#### 1930-ED & 2632-ED

The 1930-ED and 2632-ED have one Maintenance Lock, located at the machine rear.

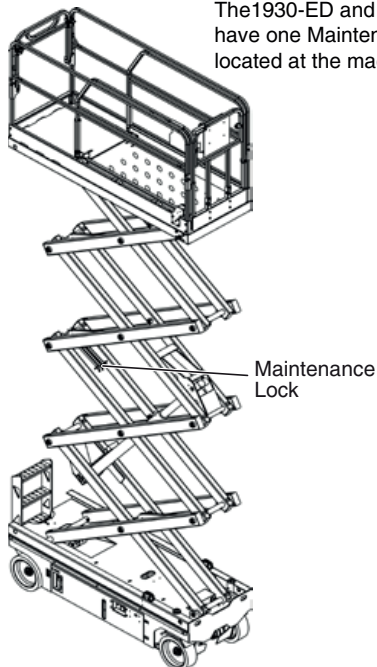

#### 3346-ED, 4046-ED & 4646-ED

The 3346-ED, 4046-ED and 4646-ED machines have two Maintenance Locks, located at the machine rear and front.

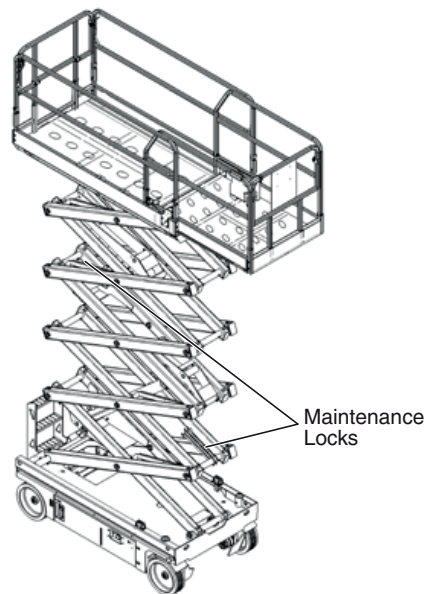

## 10. INSPECTIONS

### 10.1 PRE-START INSPECTION

The operator conduct a Pre-Start Inspection of the machine before each work shift. **DO NOT** use a damaged or malfunctioning machine.

Initial Description

- \_\_\_\_\_ Be sure that the operator's manual is complete, legible and in the storage container located in the platform.
- \_\_\_\_\_ Be sure that all decals are legible and in place.
- \_\_\_\_\_ Check for hydraulic oil leaks.
- \_\_\_\_\_ Check for battery fluid leaks.

**Check the following components or areas for damage, improperly installed or missing parts and unauthorized modifications:**

- \_\_\_\_\_ Electrical components, wiring and electrical cables
- \_\_\_\_\_ Battery connections
- \_\_\_\_\_ Electrical components, wiring and electrical cables
- \_\_\_\_\_ Battery pack and connections
- \_\_\_\_\_ Drive motors
- \_\_\_\_\_ Slide blocks/wear pads
- \_\_\_\_\_ Tires and wheels
- \_\_\_\_\_ Ground strap
- \_\_\_\_\_ Limit switches, alarm and beacon
- \_\_\_\_\_ Nuts, bolts and other fasteners
- \_\_\_\_\_ Platform entry gate
- \_\_\_\_\_ Beacons and alarms
- \_\_\_\_\_ Maintenance Lock
- \_\_\_\_\_ Platform extension
- \_\_\_\_\_ Scissor pins and retaining fasteners
- \_\_\_\_\_ Platform control handle
- \_\_\_\_\_ Brake release components
- \_\_\_\_\_ Pothole guards

**Check entire machine for:**

- \_\_\_\_\_ Cracks in welds or structural components
- \_\_\_\_\_ Dents or damage to machine
- \_\_\_\_\_ Be sure that all structural and other critical components are present and all associated fasteners and pins are in place and properly tightened
- \_\_\_\_\_ Be sure that guard rails are properly installed and secured, and that all pins and bolts are properly fastened.
- \_\_\_\_\_ Be sure that the chassis trays are closed and latched and the batteries are properly connected.



**WARNING**

**NEVER perform work or inspection on the machine with the platform elevated without first blocking the scissor assembly with the Maintenance Lock.**

## 10.2 FREQUENT INSPECTION CHECKLIST



**This checklist must be used at 3-month intervals or every 150 hours of machine use, whichever occurs first. Failure to do so could result in death or serious injury.**

Frequent Maintenance Inspections should be conducted by qualified service technicians only.  
Photocopy this page for reuse. Keep inspections records up to date.  
Record and report all discrepancies to your supervisor.  
See the Service & Parts Manual for specific instructions.

Model Number \_\_\_\_\_ Serial Number \_\_\_\_\_ Hour Meter Reading \_\_\_\_\_

Initial	Description
_____	Perform all checks listed on Pre-Start Inspection.
_____	Grease the Steering Yokes.
_____	Inspect the condition of hydraulic fluid in the reservoir. Oil should be a clear and amber in color.
_____	Batteries
_____	Electrial wiring
_____	Tires and wheels
_____	EMERGENCY STOP
_____	Key switch
_____	Horn (if equipped)
_____	Drive brakes
_____	Drive speed - stowed
_____	Drive speed - raised
_____	Drive speed - slow
_____	Tank venting system
_____	Latch Components
_____	Test Down & Pothole limit switches
_____	Test Up limit switches

### Additional maintenance requirements for severe conditions

If the machine is used in very dusty, exceptionally hot or exceptionally cold conditions, replace the Hydraulic Cap Breather Filter and Hydraulic Filter (under normal conditions replace every 6months or 300 hours, whichever comes first).



# GMG 1930ED - 4646ED

Operator's manual

## 11. TRANSPORT AND LIFTING INSTRUCTIONS

### 11.1 SAFETY INFORMATION



#### **WARNING**

This section is provided for reference and does not supersede any government or company policy regarding the loading, transport or lifting of GMG machinery. Truck drivers are responsible for loading and securing machines, and should be properly trained and authorized to operate GMG machinery. Drivers are also responsible for selecting the correct and appropriate trailer according to government regulations and company policy. Drivers must ensure that the vehicle and chains are strong enough to hold the weight of the machine (see the serial number plate for machine weight).

While loading and unloading, the transport vehicle must be parked on a level surface and secured to prevent rolling.

### 11.2 FREE-WHEEL CONFIGURATION FOR WINCHING OR TOWING



#### **DANGER**

**RUNAWAY HAZARD!** After releasing the brakes there is nothing to stop machine travel. Machine will roll freely on slopes. **ALWAYS** chock the wheels before manually releasing the brakes.

Before towing or winching the machine, it is necessary to release the brakes. Reset the brakes after towing or winching.

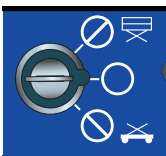

Disengage Brakes before Towing or Winching

1	Chock the wheels.
2	At the Lower Controls panel, turn the Key Switch to the Lower position.
3	At the Platform Controls, set the EMERGENCY STOP clockwise to the ON position
4	At the Ground Controls panel, press the EMERGENCY STOP.
5	Lift up red cover to Brake Release Switch and move the Brake Release Switch to UP position and hold.

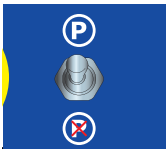

#### **Resetting Brakes**

Turn the Key Switch to the OFF position to reset the brake.

## 11.2.1 DRIVING OR WINCHING ONTO OR OFF OF A TRANSPORT VEHICLE

**! WARNING** Always attach the machine to a winch when loading or unloading from a truck or trailer by driving. Read and understand all safety, control, and operating information found on the machine and in this manual before operating the machine.

Before loading or unloading the machine, check that:

- The deck extension, controls and component trays are secure.
- The platform is fully lowered.
- All loose items have been removed.

Before driving or winching the machine:

- Attach the machine to a winch.
- Remove all machine tie downs. Remove wheel chocks.

### Driving

- Turn the Base Key Switch to PLATFORM. Check that the EMERGENCY STOP is reset by turning it clockwise.
- Enter the platform and reset the Platform EMERGENCY STOP.
- Test platform control functions.
- Select slow drive speed mode. Carefully drive the machine off the transport vehicle with the winch attached.

**Note:** The brakes are automatically released for driving and will automatically apply when the machine stops.

### Winching

- Carefully operate the winch to lower the machine down the ramp.
- Chock the wheels and engage the brakes.

### Lifting The Machine With A Forklift

- Position the forklift forks in line with the forklift pockets.
- Drive forward to the full extent of the forks.
- Raise the machine 15 cm and then tilt the forks back slightly to keep the machine secure.
- Be sure the machine is level when lowering the forks.

## 11.2.2 SECURING TO TRUCK OR TRAILER FOR TRANSPORT

- Turn the Key Switch to OFF and remove the key before transport.
- Inspect the entire machine for loose or unsecured items.
- Chock the wheels
- Use the tie-down points on the chassis for anchoring down to the transport surface.
- Use chains or straps of ample load capacity.
- Use a minimum of four (4) chains or straps.
- Adjust the rigging to prevent damage to the chains and the machine.

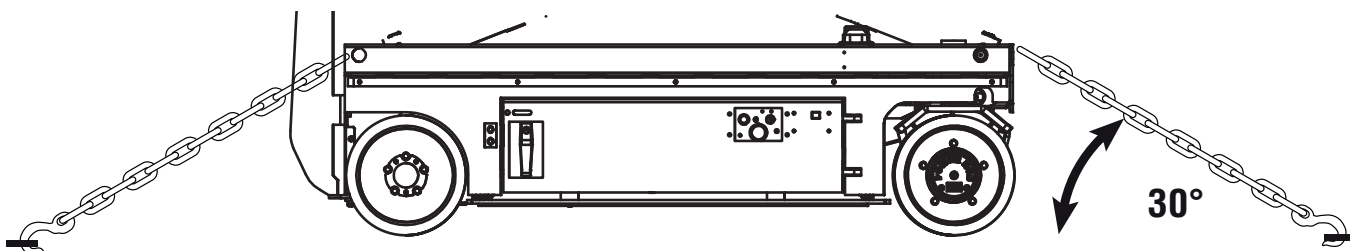



## 11.3 LIFTING INSTRUCTIONS

---



Only qualified riggers shall rig and lift the machine. Ensure that the crane, loading surfaces, spreader bars, cables, chains and straps are of sufficient capacity to withstand the machine weight. See the serial plate for the machine weight.

- Fully lower the platform. Be sure the deck extension is retracted and the controls and component trays are closed and secure. Remove all loose items from the machine.
- Determine the center of gravity of the machine.
- Attach rigging to the designated lift points only.
- Adjust the rigging to prevent damage to the machine and to keep the machine level.







**Global Machinery Group, Inc.**

## **Global Machinery Group**

Global Machinery Group, Inc.  
3428 Bullock Lane  
San Luis Obispo, CA 93401 USA  
Tel USA: +1.805.303.2066  
Toll Free (USA/Canada): 800.303.0499  
[www.goGMG.com](http://www.goGMG.com)

GMG EU office  
Leemidden 21  
2678ME DE LIER  
The Netherlands  
Tel.: +31 174 52 59 90