

## Operation Section

### Before Operation

i02601969

#### Mounting and Dismounting

SMCS Code: 7000



Illustration 143

g00037860

Typical example

Mount the machine and dismount the machine only at locations that have steps and/or handholds. Before you mount the machine, clean the steps and the handholds. Inspect the steps and handholds. Make all necessary repairs.

Face the machine whenever you get on the machine and whenever you get off the machine.

Maintain a three-point contact with the steps and with the handholds.

**Note:** Three-point contact can be two feet and one hand. Three-point contact can also be one foot and two hands.

Do not mount a moving machine. Do not dismount a moving machine. Never jump off the machine. Do not carry tools or supplies when you try to mount the machine or when you try to dismount the machine. Use a hand line to pull equipment onto the platform. Do not use any controls as handholds when you enter the operator compartment or when you exit the operator compartment.

#### Daily Inspection

SMCS Code: 1000; 7000

i0794285A

##### NOTICE

Accumulated grease and oil on a machine is a fire hazard. Remove this debris with steam cleaning or high pressure water, at least every 1000 hours or each time any significant quantity of oil is spilled on a machine.

For maximum service life of the machine, make a thorough daily inspection before you operate the machine. Remove any debris from the engine compartment and the undercarriage. Ensure that all guards, covers, and caps are secured. Inspect all hoses and belts for damage. Make the needed repairs before you operate the machine.

Inspect the area around the machine and under the machine. Look for loose bolts, trash buildup, oil, coolant, fuel, or exhaust leakage, broken parts, or worn parts.

**Note:** Watch closely for leaks. If you observe a leak, find the source of the leak and correct the leak. If you suspect a leak or you observe a leak, check the fluid levels more frequently.

Visually inspect the high-pressure fuel lines before the engine is started. If you inspect the engine in operation, always use the proper inspection procedure to avoid a fluid penetration hazard. Refer to Operation and Maintenance Manual, "High-Pressure Fuel Lines", in the Safety Section.

Inspect the condition of the equipment and of the hydraulic components.

Check all the oil levels, all the coolant levels, and all the fuel levels.

Remove any trash buildup and debris. Inspect the area between lift cylinder and lower plate of the lift tower for debris and clean as necessary. Inspect the rear portion of the right side lift cylinder tower for debris and clean as necessary.

Perform all necessary repairs before you operate the machine.

Ensure that all covers and guards are securely attached.

Adjust the mirrors for the correct rear view of the machine.

Grease all the fittings that are scheduled daily.

If equipped, inspect the status of the Fire Suppression System (FSS) on the operator control module, follow "Daily Inspections" listed in the Fire Suppression System Operator and Maintenance Manual.

Daily, perform the procedures that are applicable to your machine. Refer to the Operation and Maintenance Manual, "Maintenance Interval Schedule" "Every 10 Service Hours or Daily" category for the list of procedures.

## Machine Operation

i08016508

### Alternate Exit

SMCS Code: 7000

### Primary Exit

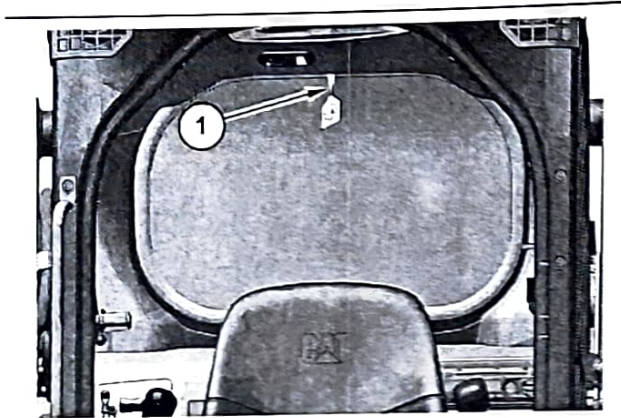

Illustration 144

g06327960

(1) Latch pin

The rear window in the machine serves as the primary alternate exit. The window will need to be removed to use the primary alternate exit. Pull on the ring at the top of the window to remove the window. This will remove the seal that holds the window in place. When the seal is taken out, carefully remove the window.

### Secondary Exit

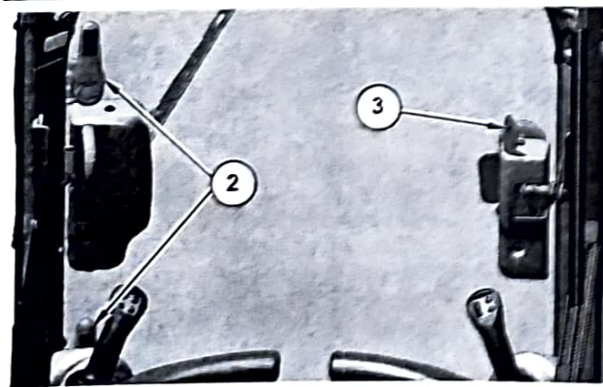

Illustration 145

g06327977

(2) Release levers for the hinge  
(3) Door Latch

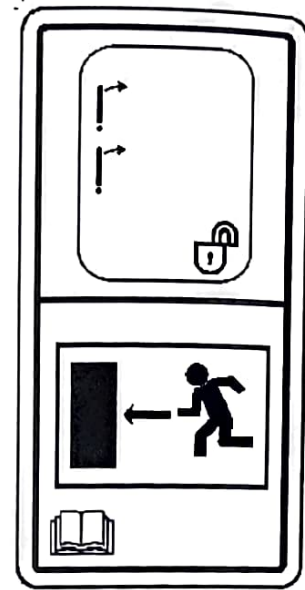

Illustration 146

g03381684

If necessary, the cab door may be removed from the hinges inside the machine. Use the following procedure:

1. Release the door from the striker (4).
2. Use the two levers (2) to release the hinge. Move both levers clockwise
3. Push the door away from the cab.



## Reassembly

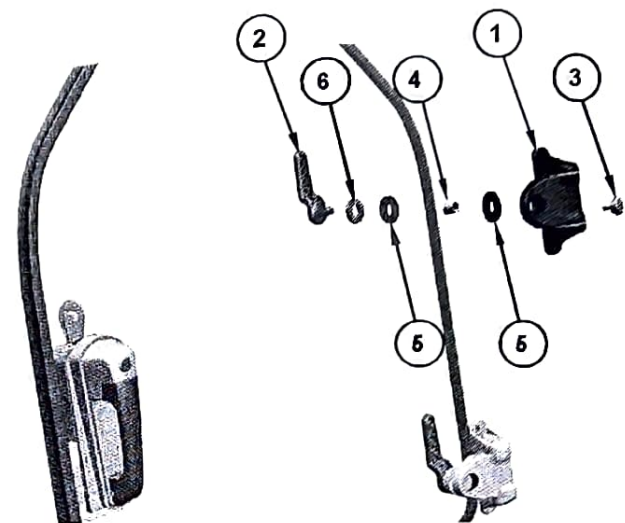

Illustration 147

g06508561

- (1) Hinge Asm
- (2) Handle Asm
- (3) Latch Asm
- (4) Bushing
- (5) Rubber Gasket
- (6) Hard Washer

1. Ensure that the components are assembled in the proper order according to illustration 147 .

**Note:** Failure to reassemble the hinges properly may negatively impact door life and function of the alternate exit.

2. With the handle assembly in the horizontal position, press the handle assembly into the latch assembly.

3. Rotate the handle assembly to the vertical position to complete the hinge reassembly.

4. Repeat for the other hinge assembly.

i07092308

## Seat Belt

SMCS Code: 7327

**Note:** This machine was equipped with a seat belt when the machine was shipped from Caterpillar. At the time of installation, the seat belt and the instructions for installation of the seat belt meet the SAE J386 and ISO 6683 standards. Consult your Cat dealer for all replacement parts.

Always check the condition of the seat belt and the condition of the mounting hardware before you operate the machine.

## Seat Belt Adjustment for Retractable Seat Belts

## Fastening The Seat Belt

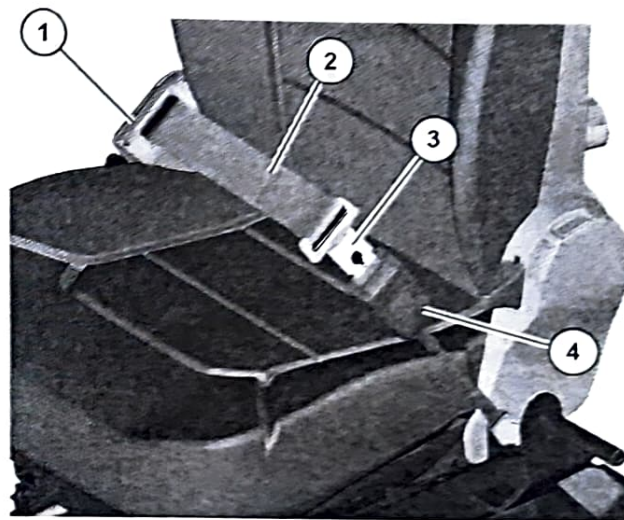

Illustration 148

g06223891

Pull seat belt (2) out of retractor (1) in a continuous motion.

Fasten seat belt catch (3) into buckle (4). Make sure that the seat belt is placed low across the lap of the operator.

The retractor will adjust the belt length and the retractor will lock in place. The comfort ride sleeve will allow the operator to have limited movement.



## Releasing The Seat Belt

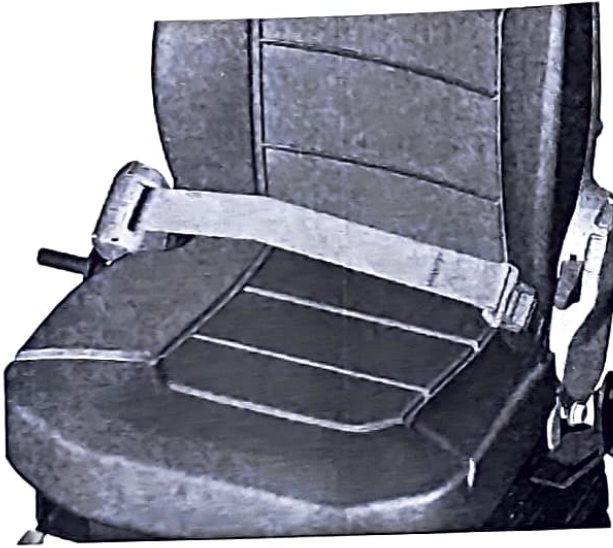

Illustration 149

g06223894

Push the release button on the buckle to release the seat belt. The seat belt will automatically retract into the retractor.

## Extension of the Seat Belt

### **WARNING**

When using retractable seat belts, do not use seat belt extensions, or personal injury or death can result.

The retractor system may or may not lock up depending on the length of the extension and the size of the person. If the retractor does not lock up, the seat belt will not retain the person.

Longer, non-retractable seat belts and extensions for the non-retractable seat belts are available.

Caterpillar requires only non-retractable seat belts to be used with a seat belt extension.

Consult your Cat dealer for longer seat belts and for information on extending the seat belts.

i08442714

## Operator Controls

SMCS Code: 7300; 7451

**Note:** Your machine may not be equipped with all the controls that are discussed in this topic.

The operation section is a reference for the new operator and a refresher for the experienced operator. This section includes descriptions of gauges, switches, machine controls, attachment controls, transportation, and towing information.

Illustrations guide the operator through correct procedures of checking, starting, operating, and stopping the machine. Operating techniques that are outlined in this publication are basic. Skill and techniques develop as the operator gains knowledge of the machine and the capabilities of the machine.

**Note:** Simple hydromechanical work tools may be shipped without hydraulic oil. Uneven movement may occur until all the air has been removed from the work tool. You may need to add hydraulic oil to the machine after the machine fills the circuits of the work tool. Refer to Operation and Maintenance Manual, "Hydraulic System Oil Level - Check" for the proper procedure for checking the hydraulic oil level.

**Note:** If the machine is not equipped with a cab that is enclosed, Caterpillar recommends the use of a flying object guard. If the machine is equipped with an enclosed cab, operate the machine with the cab door in the CLOSED position.

# Left Side Controls

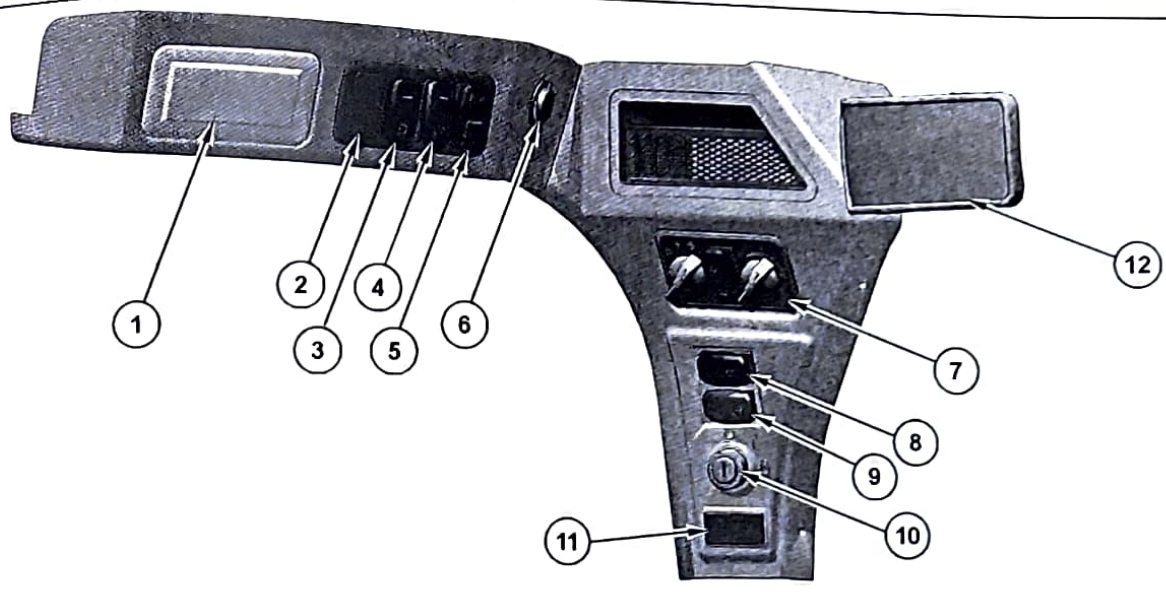

Illustration 150

g06330870

- (1) Cab dome light
- (2) Auxiliary electrical control
- (3) Multifunction switch for left-hand trigger
- (4) Self-Level System Switch

- (5) Work tool coupler control switch
- (6) Power Supply Port
- (7) Heating and air conditioning controls
- (8) Window wiper and washer control

- (9) Parking brake switch
- (10) Engine key start switch
- (11) Selectable control pattern switch
- (12) Mirror



## Cab Dome Light (1)



**Cab Dome Light** – Press either side of the light to turn on the light. Move the light to the middle position to turn off the light.

## Auxiliary Electrical Control "AUX 8" (2)

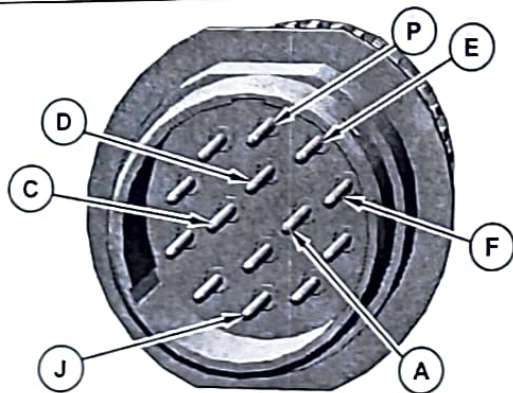

Illustration 151

g06353203

Typical electrical connection on the loading arm

- (A) Left-Hand Trigger Control "AUX 7"
- (C) C- Control
- (D) C+ Control
- (E) C2 Control
- (F) C1 Control
- (J) Auxiliary Electrical Control "AUX 8"
- (P) +12V with KEY ON



**Auxiliary Electrical Control "AUX 8"** – The auxiliary electrical control supplies continuous electrical power to pin (J) on

the connector for the work tool on the loader arm. Press the bottom of the switch to turn on electrical power. Press the top of the switch to turn off electrical power.

## Multifunction Switch for the Left-Hand Trigger (3)

This switch is used to toggle the function of the trigger on the left-hand joystick between Two Speed and the Auxiliary Electrical Function "AUX 7".

### Two-Speed



**Two-Speed** – Push the top of the multifunction switch to use the trigger for the two-speed control. Press the trigger and release the trigger on the front of the left-hand joystick to activate two-speed travel mode. To return to one-speed travel mode, press the trigger and release the trigger again.

**Note:** Keep the work tool close to the ground when you travel in two-speed mode. This method will maximize the stability of the machine.

**Note:** Do not move the multifunction switch while the two-speed function is active. Ensure that the machine is in one-speed mode before the Auxiliary Electrical Function "AUX 7" is activated.

**Note:** The Creep Mode must be turned off to shift the machine into two speed. If you activate the Creep Mode, the machine will return to one-speed mode. If you set the parking brake, the machine will return to one-speed mode.

## Auxiliary Electrical Function "AUX 7"

**Note:** If the switch is not present, the trigger on the left-hand joystick only provides this auxiliary function.



**Auxiliary Electrical Function "AUX 7"** – Push the bottom of the switch to enable the seventh auxiliary electrical function.

Pull the trigger and hold the trigger on the left-hand joystick to provide electrical power to pin (A) on the work tool connector on the loader arm. Release the trigger to deactivate the control.

## Self-Level System Switch (4)



Press the bottom of the switch to enable self-level. The alert indicator for Self-Level will illuminate indicating the system is on. Press the top of the switch to turn off the Self-Level system.



### Self-Level

### Return to Dig

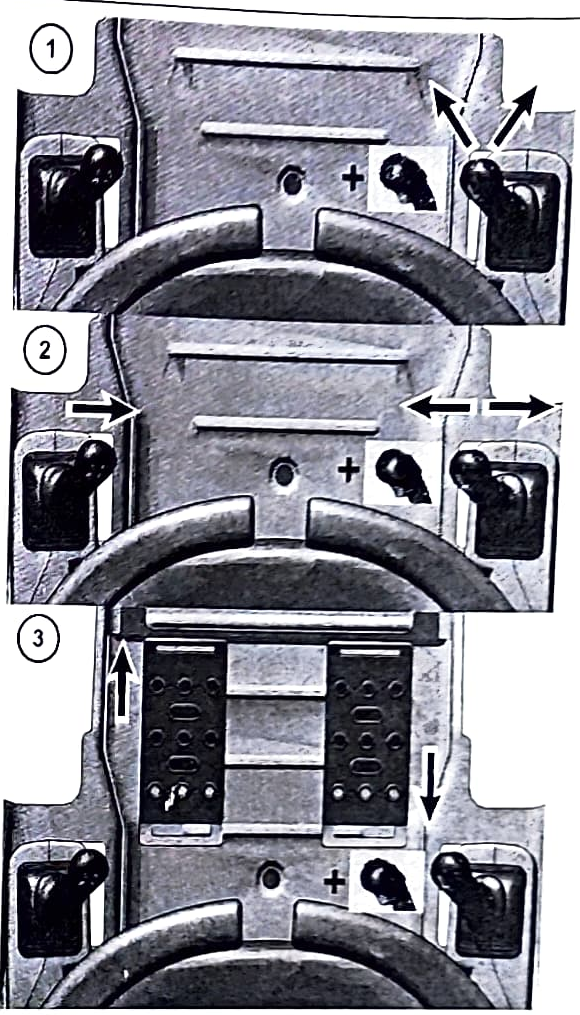
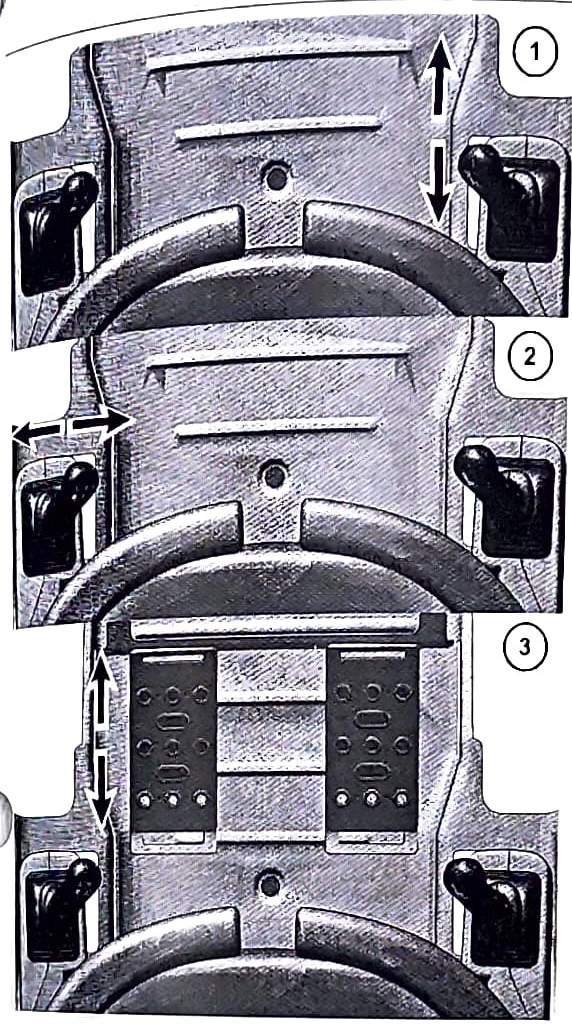

Illustration 152  
g06354572  
(1) Cat Control Pattern  
(2) H-Control Pattern  
(3) Hand and Foot Control Pattern

Illustration 153  
g06354582  
(1) Cat Control Pattern  
(2) H-Control Pattern  
(3) Hand and Foot Control Pattern

The Dual Direction Self-Level feature maintains the approximate starting angle of the work tool as the loader arms are raised or lowered.

The Return to Dig feature lowers the lift arms and returns the work tool to a user-selected target angle. Set the work tool to the desired angle using the controls. Pull the right-hand joystick trigger and hold for 5 seconds to set the target angle. The Self-Level alert indicator will flash twice to confirm that the angle was accepted. After a dump cycle, with the lift arms raised, give a momentary Lower and Dump or Lower and Tilt Back command. Momentarily press and release the right-hand joystick trigger to initiate Return to Dig mode. The lift arms will lower to the stops and the work tool will return to the user-selected target angle without further operator input.

**Note:** The target angle will reset to a factory default when the machine is keyed off. The factory default approximates a level bucket with the lift arms in the lowest position.



## Work Tool Positioner

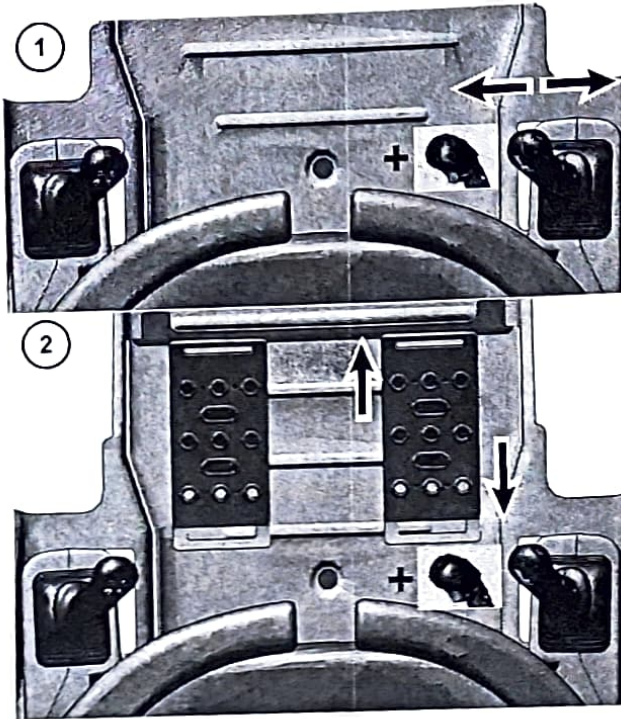

Illustration 154

g06354805

- (1) Cat Control Pattern and H-Control Pattern  
(2) Hand and Foot Control Pattern

The Work Tool Positioner feature returns the work tool to a user-selected target angle. Set the work tool to the desired angle using the controls. Pull the right-hand joystick trigger and hold for 5 seconds to set the target angle. The Self-Level alert indicator will flash twice to confirm that the angle was accepted. Start the work tool in the direction of the target angle by giving a momentary Dump or Tilt Back command. Momentarily press and release the right-hand joystick trigger to initiate Work Tool Positioner mode. The work tool will return to the user-selected target angle without further operator input. Work Tool Positioner mode has no impact on the lift arm position.

**Note:** The target angle will reset to a factory default when the machine is keyed off. The factory default approximates a level bucket with the lift arms in the lowest position.

## Work Tool Coupler Control (5)

### **WARNING**

Improper Attachment of the Work Tool could result in injury or death.

Do not operate the machine without confirmation that the coupler pins are fully engaged. Follow the operating procedures in the Operation and Maintenance Manual.

**Work Tool Coupler Control** – The work tool coupler controls the engagement of the coupler pins.

**Note:** The hydraulic quick coupler only works while the ENGINE IS RUNNING.



**Disengaged** – Push the red button upward and press the bottom of the switch. Hold the switch in the downward position until the coupler pins disengage.



**Engaged** – Press the top of the switch and hold the top of the switch until the coupler pins engage.

Refer to Operation and Maintenance Manual, "Work Tool Coupler Operation" for the proper procedure for the work tool coupler.

## Power Supply Port (6)

This electrical outlet is a 12V power round receptacle in machines equipped with the standard display or a USB port in machines equipped with the Advanced Display.

Either may be used to operate electrical accessories. The USB port may be used by the owner to upload a custom image to the Advanced Display. See Operator Controls, Right Side Controls (Alternate), Menu Screen, Service Menu". The USB port is also used by the Cat dealer to service the Advanced Display software as needed.

## Heating and Air Conditioning Control Panel (7)

Heating and air conditioning control panel (7) houses the switches for controlling the temperature and operator comfort level inside the cab.

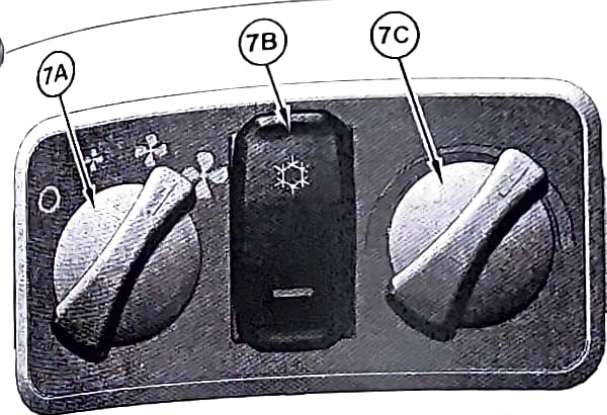

g06330900

Illustration 155

 **Fan Speed Control (7A)** – The fan speed switch controls the three-speed blower fan motor.

 **Air Conditioning Switch (7B)** – Depress A/C switch (7B) to activate the air conditioning system. Turn fan speed switch (7A) to LOW, MEDIUM, or HIGH speed. Adjust temperature variable control (7C) for the desired temperature.

 **Temperature Variable Control (7C)** – Turn the control knob anywhere between the blue area (left) and the red area (right). This action will control the amount of heating and cooling.

## Window Wiper and Window Washer (8)

 **Window Wiper and Window Washer** – Move the switch to the middle position to turn on the wiper. Press the right side of the switch to operate the washer. Press the left side of the switch to turn off the wipers.

## Parking Brake Control (9)

 **Parking Brake Control** – After starting the engine, press the right side of the switch and release the switch to disengage the parking brake and enable the hydraulic implement system. Successive operation of this switch will only cycle the parking brake on and off and will not impact the hydraulic implement system.

**Note:** The parking brake will engage when the engine is stopped. The parking brake will engage when the armrests are moved to the RAISED position. The parking brake will engage when the operator leaves the operator seat for a time.

**Note:** If the switch for the Joystick Control Pattern is installed, select a pattern to release the parking brake. See Selectable Control Pattern Switch (11).

## Engine Key Start Switch (10)

 **OFF** – Insert the engine start switch key only from the OFF position and remove the engine start switch key only from the OFF position. Turn the engine start switch key to the OFF position to stop the engine. In the OFF position, there is no power to most electrical circuits on the machine. The cab dome light is operational even when the engine start switch is in the OFF position.

 **ON** – Turn the engine start switch key clockwise to the ON position to activate all the cab circuits.

 **START** – Turn the engine start switch key clockwise to the START position to crank the engine. Release the engine start switch key after the engine starts and the engine start switch key returns to the ON position.

**Note:** If the Machine Security System is enabled, the correct pin code must be entered before the machine will start. See "Anti-Theft Security System", for further information.



**Note:** If the engine fails to start, turn the engine start switch key to the OFF position to attempt to start the engine again. Refer to the Operation and Maintenance Manual, "Engine Starting" for more details about starting the engine.

## Selectable Control Pattern Switch (11)

If the machine is equipped with the optional Selectable Control Pattern feature, a rocker switch will be present at this location with the number (1) on one side and the number (2) on the other side. After starting the machine, a control pattern must be selected before the parking brake can be released. Press the switch to the (1) position for Cat Control Pattern or press the switch to the (2) position for H-Control Pattern. The alert indicators (1) and (2) will blink until a control pattern is selected. Once a control pattern has been selected, activating the parking brake will not affect the selection of the pattern. Keying the machine off will reset the control pattern selection. Refer to the section "Joystick Controls" for detailed information on the possible joystick control patterns.

## Mirror (12)

Adjust the rear view mirror properly to view objects that are behind the machine.

## Right Side Controls

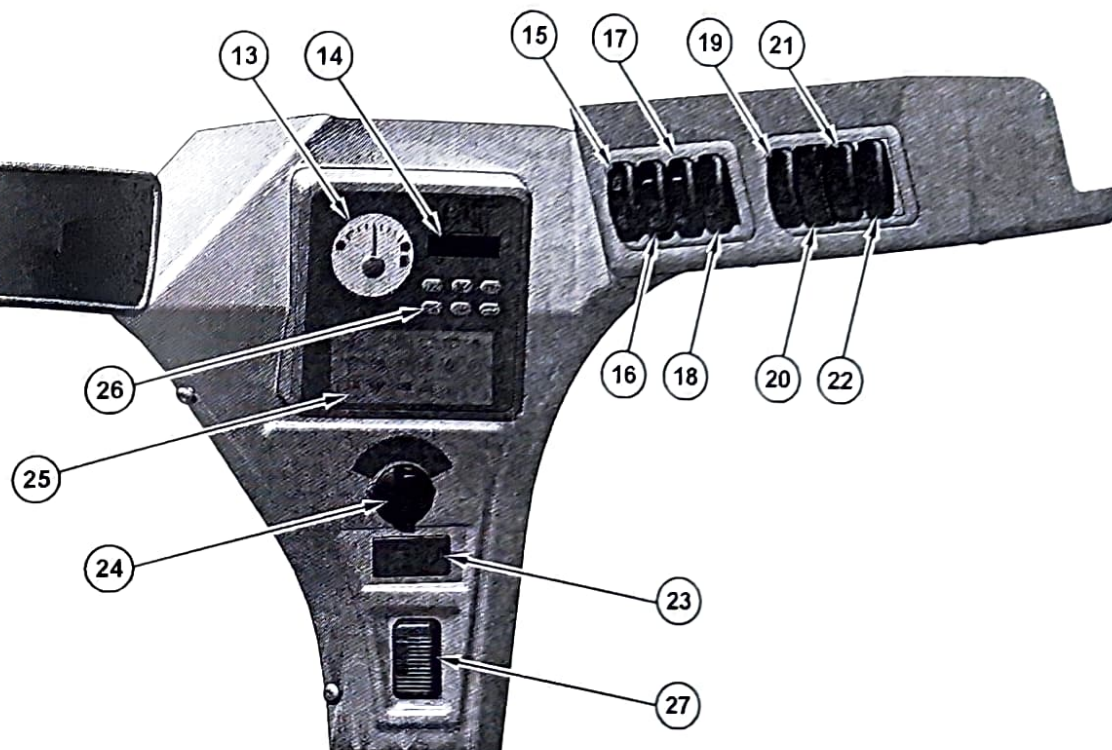

Illustration 156

g06354503

- (13) Fuel gauge
- (14) Service hour meter
- (15) Hydraulic lockout
- (16) Front working lights
- (17) Rear working lights

- (18) Continuous hydraulic flow
- (19) Ride control
- (20) Reversing fan
- (21) Roading lights
- (22) Hazard lights

- (23) Turn Signal
- (24) Engine speed control knob
- (25) Alert indicator panel
- (26) Anti-Theft security soft keys
- (27) Bluetooth microphone

## Fuel Level Gauge (13)

 **Fuel Level Gauge** – The needle in the red range indicates low fuel.

## Service Hour Meter (14)

 **Service Hour Meter** – The service hour meter indicates the total number of hours the engine has been running. The service hour meter should be used to determine service hour maintenance intervals. This window will also display the Basic Machine Security information. See Basic Security Soft Keys.

## Hydraulic Lockout (15)

 **Hydraulic Lockout** – Press the top of the switch to disable the hydraulic functions. Press the bottom of the switch to enable the hydraulic functions.

**Note:** Activate the hydraulic lockout when you are roading the machine to prevent unplanned movement of the work tool and the loader arms.

**Note:** If your machine is equipped with a Hydraulic Lockout switch only and the application requires the ability to override the hydraulic interlock system, see your Cat dealer to have a dual purpose switch installed

## Hydraulic Lockout and Interlock Override (15 If Equipped)

 **Hydraulic Lockout** – Press the top of the switch to disable the hydraulic functions. Return the switch to the middle position to activate the hydraulic functions.

**Note:** Activate the hydraulic lockout when you are roading the machine to prevent unplanned movement of the work tool and the loader arms.





**Interlock Override** – The interlock override allows the auxiliary hydraulic circuits to function with the armrest in the **RAISED** position. First bring the machine to a complete stop. Activate the continuous flow control. Press the bottom of the interlock override switch and release the switch to activate the interlock override function. To turn off the interlock override and continuous flow, press the bottom of the switch and release the switch again.

### **WARNING**

Inadvertent movement of the work tool may occur if the interlock override function is used with work tools. This may result in personal injury or death. Only use interlock override function for hand-held work tools.

### **NOTICE**

Before putting the machine into hydraulic interlock override, the work tool hydraulic lines must be connected to the machine couplers. Hooking hydraulic lines up with pressure will result in destroyed seals in the coupler and result in poor hydraulic performance.

**Note:** Certain work tools should not be operated with the hydraulic interlock system overridden. Consult your work tool Operation and Maintenance Manual for further information. If the machine will run a work tool where the presence of this switch represents a possible safety issue, see your Cat dealer to have the switch replaced with one having the Hydraulic Lock out feature only.

**Note:** The alert indicator for the parking brake will light when the interlock override is activated. When the interlock override is deactivated, press the parking brake switch to disengage the parking brake and activate the hydraulic functions.

### **Switch on the Cab Door**

A switch is provided on the cab door that prevents the work tool from operating when the cab door is open. If the cab door is not installed or if the cab door is removed, the cab door jumper plug must be installed to operate a hydraulic work tool.

**Note:** The cab door jumper plug is located behind the seat on the machine's left-hand side. The cab door jumper plug is cable-strapped to the cab harness near the point of use. To enable the work tool hydraulics with the front door removed, cut the cable strap securing the jumper plug to the cab harness, disconnect the front door harness from the cab harness behind the seat, and connect the front door jumper plug in its place.

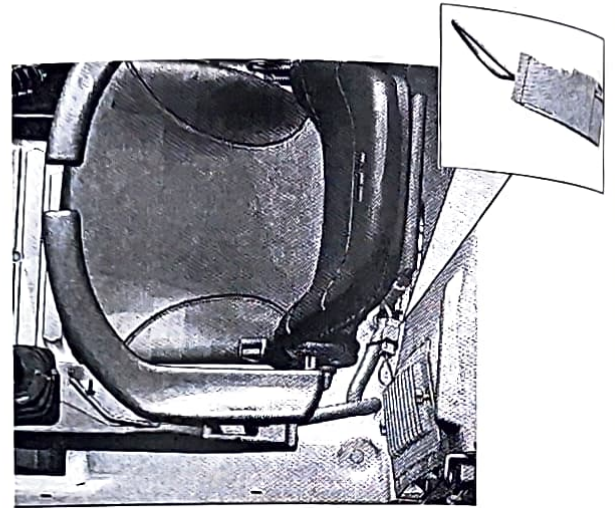

Illustration 157

g06354134

If the cab door jumper plug cannot be found, a plug can be assembled. Refer to M0069152, Assembly of Safety Bypass Plug for the Front Door on Compact Track Loaders, Multi-Terrain Loaders, and Skid steer Loaders for instruction on assembling the plug.

### **Front Work Lights (16)**



**Front Work Lights** – Press the bottom of the switch to turn on the lights. Press the top of the switch to turn off the lights.

### **Rear Work Lights (17)**



**Rear Work Lights** – Press the bottom of the switch to turn on the lights. Press the top of the switch to turn off the lights.

### **Continuous Flow Switch (18)**



**Continuous Flow** – Continuous flow control (18) supplies continuous flow of hydraulic fluid to the auxiliary hydraulic circuit without continuously holding the auxiliary hydraulic control. Press the bottom of the continuous flow rocker switch. The continuous flow alert indicator will flash continuously indicating the system is in the "Continuous Flow Ready Mode". Press either of the two auxiliary hydraulic switches (1) or (2) that are on the right-hand joystick. If equipped, you may also move the thumb wheel on the right-hand joystick to the desired flow position and hold either of these commands for several seconds. The continuous flow alert indicator will stop flashing and remain



tilt continuously. Releasing the button or thumb wheel now will engage Continuous Flow Mode, providing flow to the auxiliary hydraulic circuit without further command input. To disengage continuous flow, either press the bottom of the continuous flow switch, press either of the two auxiliary hydraulic switches or operate the thumb wheel in either direction.

## Ride Control (19)

Ride Control helps with smoothing the ride of the machine. Travel over rough terrain causes bucket movement. The ride control system uses the lift cylinders as shock absorbers. The lift cylinders dampen the forces from the work tool.

 **Ride Control – Press the bottom of the switch to turn on the ride control. Ride control will activate and the alert indicator will illuminate at the appropriate speed. Press the top of the switch to turn off the ride control.**

**Note:** The ride control will deactivate and the indicator will not be illuminated at the appropriate speed. The ride control will also deactivate if the tilt function for the work tool is operated.

Default activation speed is approximately 8 km/h (5.0 mph) for wheeled machines and 6 km/h (3.7 mph) for tracked machines.

**Note:** If the Advanced Display is equipped, the Ride Control activation speed may be adjusted to better suit the application if needed. Refer to Operation and Maintenance Manual, "Right Side Controls (Alternate), Ride Control" for more information.

## Reversing Fan (20)

The machine may be equipped with a reversing fan. Momentarily reversing the cooling fan direction aids in removing debris from the screened area of the engine enclosure, thereby improving air flow across the engine radiator and hydraulic oil cooler which may help the machine run cooler.

 **There are 3 modes for the reversing fan to function in, all functions are controlled by a switch in the cab.**

- OFF position (normal demand fan operation) Switch CENTERED.
- AUTOMATIC position (this mode sets the fan to reverse at set intervals and duration set by Cat dealer) Switches UP.

- MANUAL OVERRIDE position (a MOMENTARY SWITCH that allows the operator to force a set cycle to occur) Switch is pressed down and springs back up.

**Note:** The reversing cycle parameters for duration and frequency are user adjustable through the advanced display. See "Operator Controls, Right Side Controls (Alternate), Menu Screen, Operator Settings, Reversing Fan" for details. The reversing cycle parameters are dealer adjustable regardless of the monitor equipped.

- Default reversing cycle frequency is once every 30 minutes.

- Default reversing cycle duration is 8 seconds.

## Roading Lights (21)



**Roading Lights** – Move the switch to the middle position to turn on the control panel lights and position lights. Press the bottom of the switch to turn on the front low beams. Press the top of the switch to turn off the lights.

## Hazard Lights (22)



**Hazard Flasher Control** – Press the bottom of the switch to activate the hazard flashers. Press the top of the switch to deactivate the hazard flashers.

## Turn Signals (23)



**Turn Signals** – Press the left of the switch to turn on the left turn signals. Press the right of the switch to turn on the right turn signals. Move the switch to the middle position to turn off the turn signals.

## Engine Speed Control Knob (24)

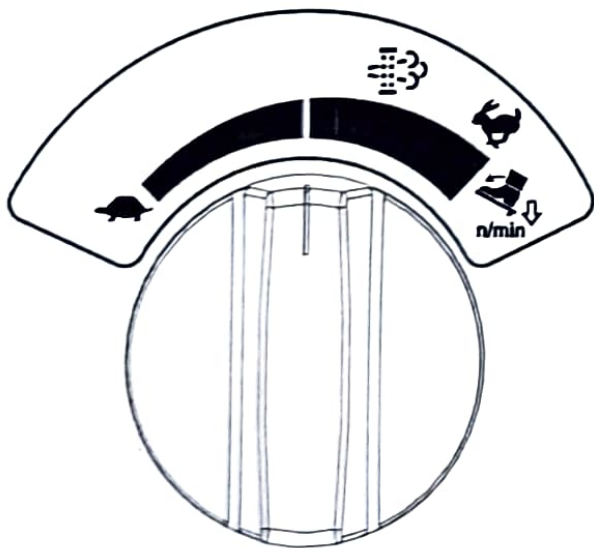

Illustration 158

g03618758

Use the knob to set the engine speed. Use the engine speed control knob when you want to set a constant engine speed. Move the knob clockwise to increase engine speed. Move the knob counter clockwise to decrease engine speed.

When the knob is fully clockwise, the engine speed control pedal, if equipped, become a deceleration pedal to lower engine RPM. The engine speed control pedal will temporarily override the engine speed control set point.

**Note:** The deceleration function will not lower the RPM to low idle. Do not use this function as a braking function.

**Note:** There are several features that may impact the low idle of the machine. Refer to Operation and Maintenance Manual, "Engine Starting" for more detailed information.

When the DPF light is on (if equipped), regeneration is needed. The operator can increase the engine speed to the active regeneration threshold. This is the green shaded area on the engine speed control knob that has the DPF symbol.

Refer to this Operation and Maintenance Manual, "Diesel Particulate Filter Regeneration".

## Alert Indicator Panel (25)



Illustration 159

Basic electronic display window

g06354091



Refer to the section Operator and Maintenance Manual "Alert Indicators" for a description about the status indicators.

## Anti-Theft Security System Soft Keys (26)

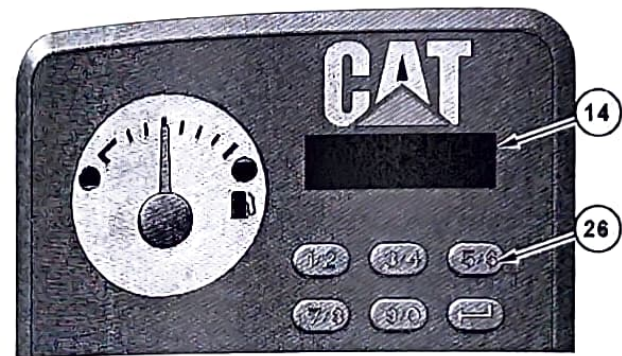

Illustration 160 g06354085

Basic electronic display window

- (14) Service hour meter window
- (26) Anti-Theft Security System

## Entering the Pin

If the Anti-Theft Security System is enabled, service hour meter window (14) will display "COdE" at machine start-up. This event occurs when key start switch (10) is moved to the ON position. Enter the secure PIN number using soft keys (26). Press the appropriate key to enter the secure code. For odd numerals (1, 3, 5, 7, or 9), press the appropriate key one time. For even numerals (2, 4, 6, 8 or 0), press the appropriate key twice. After the code is entered, press the arrow key to submit the code.

If the entered PIN number is correct, the machine service hours will display in the service hour meter window (14). Key start switch (10) may be moved to the START position to start the machine.

If the entered PIN number is incorrect, the window will flash the word "CODE" for several seconds before another attempt can be made.

**Note:** For security purposes, in the event an incorrect PIN is entered five times consecutively, the system will lock down for 15 minutes, during which period even a correct PIN will not allow the engine to crank. After the 15 minute lockdown period, entry of a correct PIN will unlock the system as usual.

## Right Side Controls (Alternate)

## Changing the Pin

The factory default PIN is "1111" and should be changed by the machine owner as soon as possible after enabling the Anti-Theft Security System. The PIN can be changed through the Standard Display to any 4-6 digit code. To change this, the system must be unlocked first by entering the current secure PIN, then simultaneously holding down the soft keys labeled "1/2" and "5/6" for 3 seconds. The system will prompt for a new "CODE" to be entered twice before accepting this as the new PIN.

## Bluetooth Microphone (27)

This microphone may be set up with your mobile telephone to provide a hands-free method of communicating. See the operating manual of your mobile device for instructions of connecting with the Bluetooth microphone.



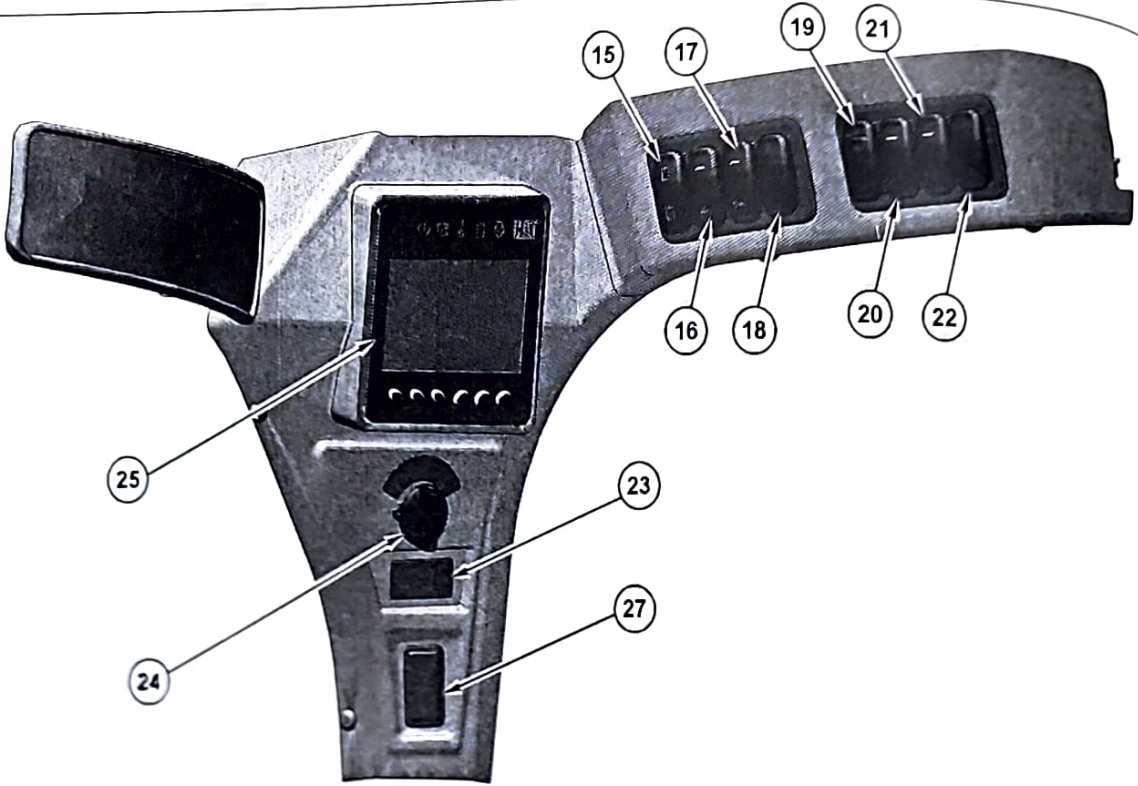

Illustration 161

g06353260

- (15) Hydraulic lockout
- (16) Front working lights
- (17) Rear working lights
- (18) Continuous hydraulic flow

- (19) Ride control
- (20) Reversing Fan
- (21) Roading lights
- (22) Hazard lights

- (23) Turn Signal
- (24) Engine speed control knob
- (25) Advanced Display Module
- (27) Bluetooth microphone

### Advanced Display Module (If Equipped) (25)

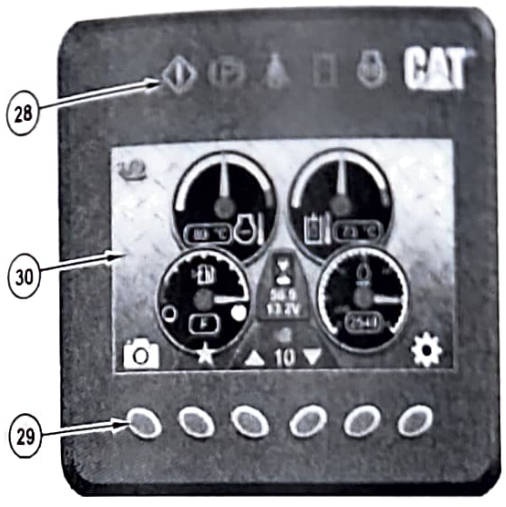

### Display Window (30)

The Display window will display the welcome screen, the main monitoring screen, and the various menu and adjustment screens. The display window will also become the Backup Camera monitor when that feature is active. See "Backup Camera Mode"

### Monitoring Screen

The monitoring screen is the primary screen that displays information to the operator during most operations. Several background color schemes and gauge layouts are available for selection by the operator. See "Menu Screen, Display Settings"

Illustration 162 g06406125

### Advanced electronic display window

- (28) Dedicated Alert Indicators
- (29) Soft Input Keys
- (30) Display Window

The optional Advanced Display has several built-in features which are arranged into menu screens.

### Dedicated Alert Indicators (28)

There are several dedicated alert indicator lamps located across the top of the Advanced Display. All other alert indicators will be icons located along the sides of the display window & will activate as needed. See "Alert Indicators".

### Soft Input Keys (29)

There are six soft input keys located across the bottom of the Advanced Display. These keys are used to navigate among the various menu screens and to input operator selections within the menu screens. The functions will vary depending on the menu. The current function will be displayed as an icon on the display window directly above the key.



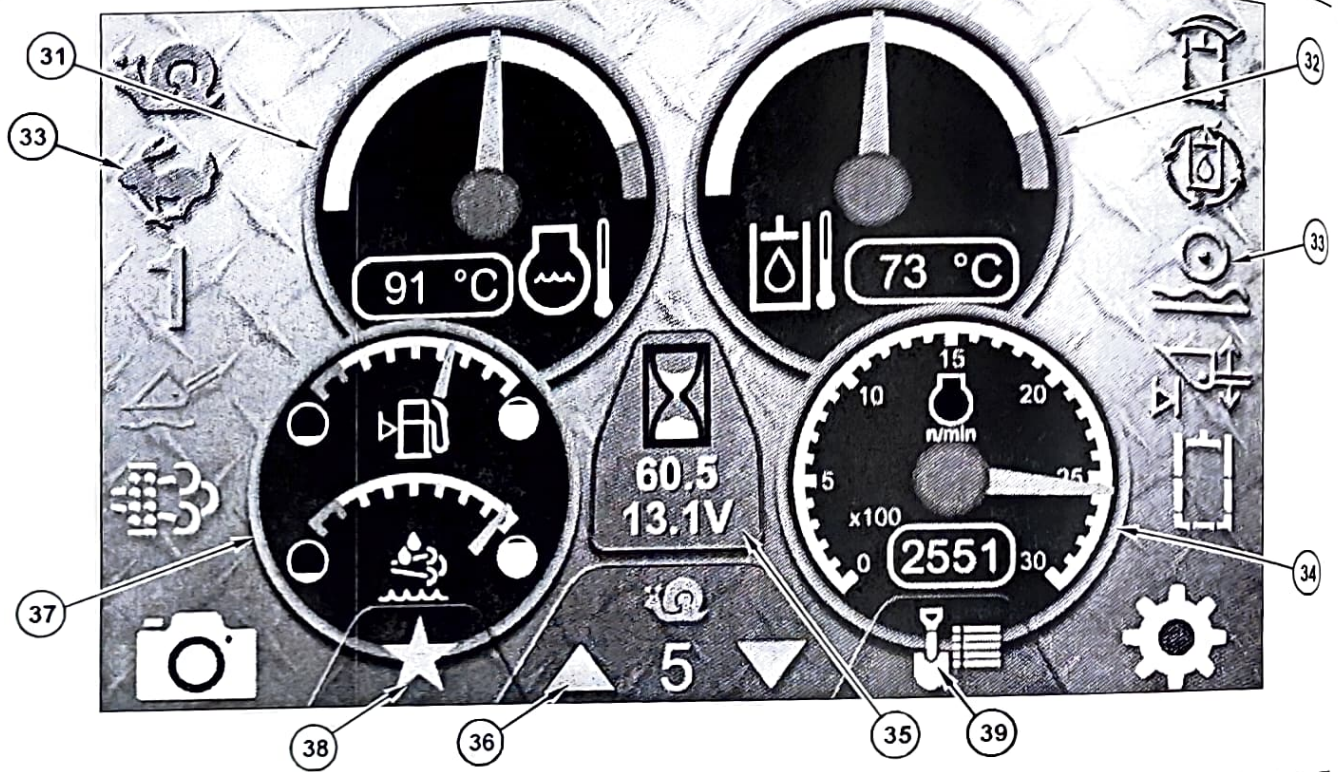
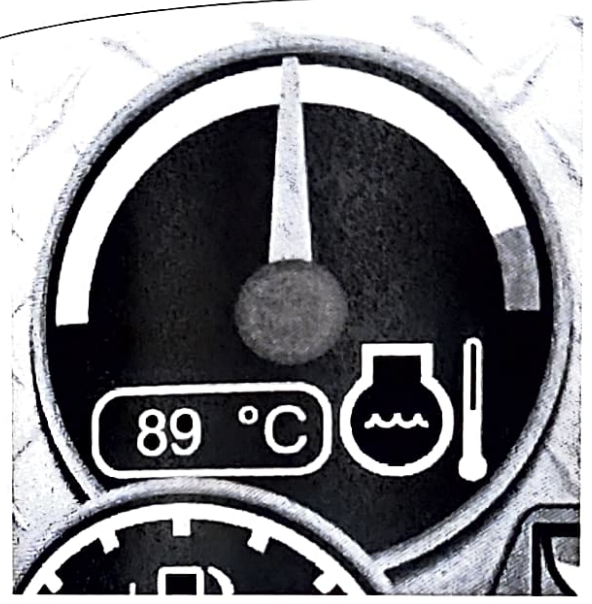

Illustration 163

Default layout of monitoring screen

- (31) Engine Coolant Temperature Gauge
- (32) Hydraulic Oil Temperature Gauge
- (33) Alert Indicators
- (34) Engine Speed Gauge
- (35) Service Hour Meter
- (36) Creep Controller
- (37) Fuel and Diesel Exhaust Fluid (DEF) Level Gauge and SCR Warning Alert Indicator
- (38) Favorites
- (39) Smart Attachment Portal

### Engine Coolant Temperature Gauge (31)



### Hydraulic Oil Temperature Gauge (32)

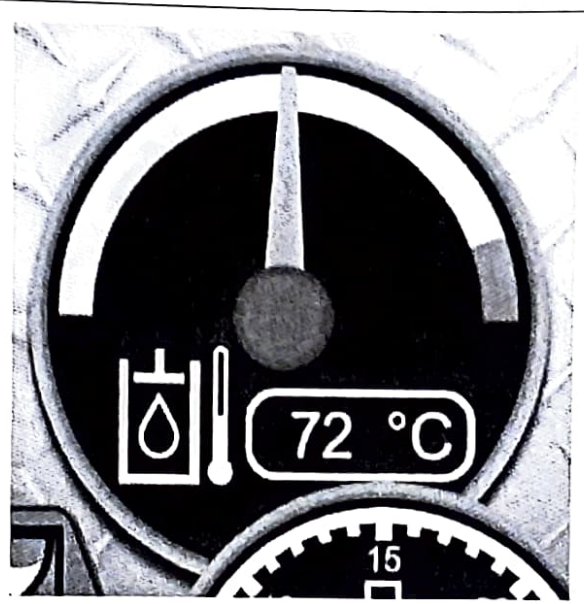

Illustration 164 g06406181

Illustration 165 g06406186

The needle in the red zone indicates that the engine coolant temperature is too high. If the gauge numerical values are enabled, the background will change from black to red to indicate that the engine coolant is approaching an unsafe temperature. The machine should be stopped soon and the engine set to low idle to allow the engine to cool. See "Operator Settings, Digital Readout".

The needle in the red zone indicates that the hydraulic oil temperature is too high. If the gauge numerical values are enabled, the background will change from black to red to indicate that the hydraulic oil temperature is approaching an unsafe temperature. The hydraulics functions should be stopped soon and the engine set to low idle to allow the hydraulic system to cool. See "Menu Screen, Display Setting, Digital Readout".

### Alert Indicators (33)



Illustration 166 g06406191

There are several alert indicator icons located along the sides of the display window & will activate as needed. See "Alert Indicators" for a description of the warnings.



**Engine Speed Gauge (34)**

Illustration 167

g06406197

The needle in the red zone indicates that the engine RPM is too high. If the gauge numerical values are enabled, the background will change from black to red to indicate that the engine speed is above the allowable HIGH IDLE limit. The throttle should be turned down to the acceptable range. The CAT dealer should be contacted to determine the cause. See "Display Settings, Digital Readout".

**Service Hour and Battery Voltage Meter (35)**

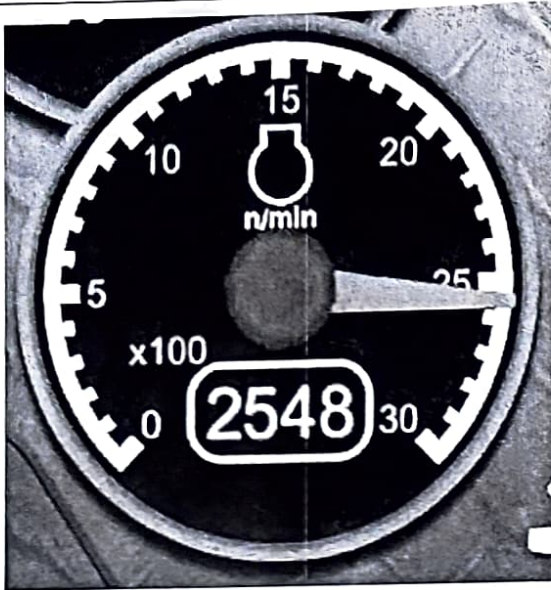
Illustration 168

g06406208

The service hour meter indicates the number of engine running hours for the machine. The hours should be used to determine which maintenance interval service items to perform. The hourglass icon blinks slowly when the engine is running indicating that hours are being accrued. The hour meter also indicates the current battery voltage.

**Creep Controller (36)**

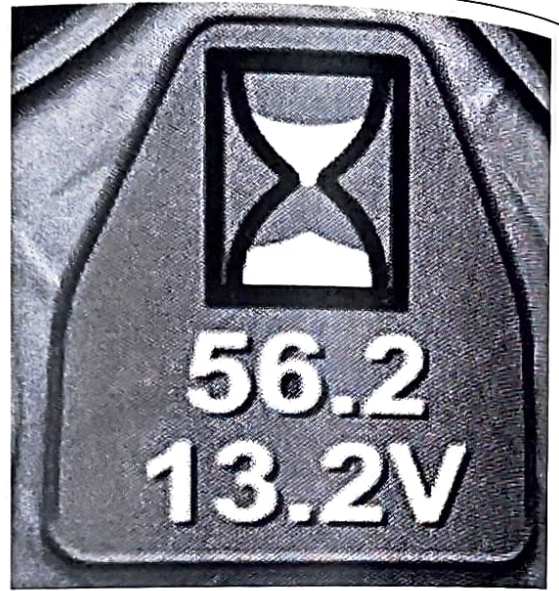
Illustration 169

g06406224

This controller will be displayed when "Creep Control" is engaged. Reference the section, "Operator Controls, Joystick Controls". This controller allows the operator to adjust the creep setting from the main screen without having to enter the Creep Control sub screen. See the section, "Menu Screen, Operator Settings, Creep Control".

**Note:** The optional Advanced Display module is required for Creep Control feature.

### Fuel and Diesel Exhaust Fluid (DEF) Level Gauge and SCR Warning Alert Indicator (37)

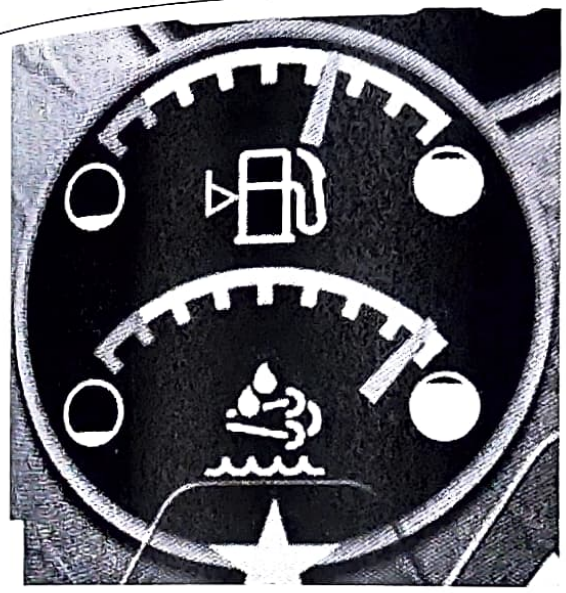

Illustration 170 g06406242

The fuel level gauge indicates the amount of fuel that remains in the fuel tank. The needle in the red range indicates low fuel.

On machines which require diesel exhaust fluid (DEF), this gauge will contain two independent needles. The top needle will indicate the amount of fuel that remains in the fuel tank. The bottom needle will indicate the amount of DEF that remains in the DEF tank.

**Note:** DEF will be consumed at a significantly slower rate than diesel fuel.

The icon below the DEF gauge is designated the SCR Warning alert indicator. The status of this lamp will vary based on the SCR warning levels. Refer to Operation and Maintenance Manual, "Selective Catalytic Reduction Warning System" for complete details.

### Favorites Icon (38)



Illustration 171 g06406246

There are several settings within the "Machine Settings" and "Display Settings" menus that may be selected as the "Favorite". This is useful for quickly recalling an often used setting without having to navigate the menu system in the normal manner.

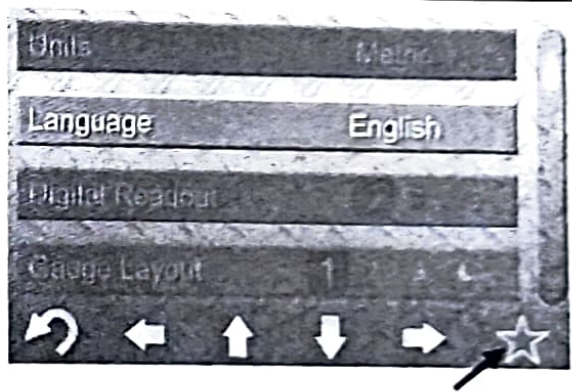

Illustration 172 g06406250

Anytime an open star icon appears over the right most soft key, the currently highlighted setting may be chosen as the "Favorite" by pressing the soft key. The open star icon will become solid indicating that setting is now the "Favorite".

When a "Favorite" is established, a solid star icon will appear above one of the soft keys anytime the main monitoring screen is the active display. Pressing this soft key will immediately jump the user to the sub menu where the "Favorite" setting is located and highlight the setting.

Pressing the right most soft key while any other eligible setting is highlighted will make this setting the new "Favorite". Pressing the right most soft key while the current favorite is highlighted will turn the "Favorite" off, indicated by changing the solid star icon back to an open star.

**Note:** There can only be one "Favorite" at any time.



## Smart Attachment Portal (39)



Illustration 173

g06452816

The menu screens for smart attachments are accessed from the Monitoring Screen by pressing the soft key under this icon. The portal to smart attachment screens is only available when the machine ECM detects the presence of a smart attachment via the machine's electrical connector. The smart attachment monitoring and adjustment screens will vary depending on which attachment is connected.



Illustration 174

g06452823

Example: Monitoring Screen

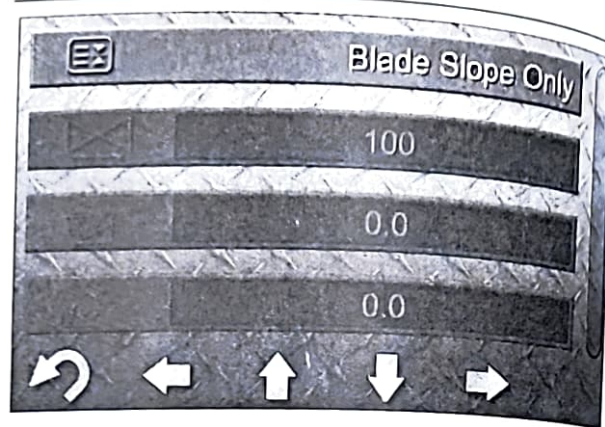

Illustration 175

Example: Adjustment Screen

g06452831

**Note:** A detailed description of the smart attachment's monitoring and adjustment screens will be found in the attachment's Operation and Maintenance Manual..

## Machine Setting Menu

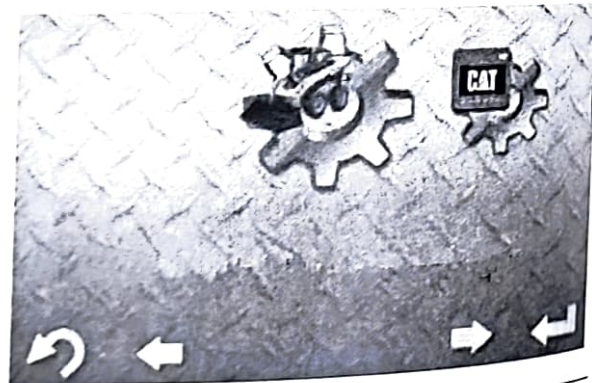

Illustration 176

g06406271

The "Machine Settings" menu allows the operator to adjust several machine response and performance settings. These settings will be stored under each operator profile. When the Anti-Theft Security System is enabled, the settings take effect each time an Operator Code is entered at the log in prompt. If the Anti-Theft Security System is not enabled, the operator settings at the time of the previous KEY OFF will remain in effect. See "Anti-Theft Security System".

## Drive System Sensitivity

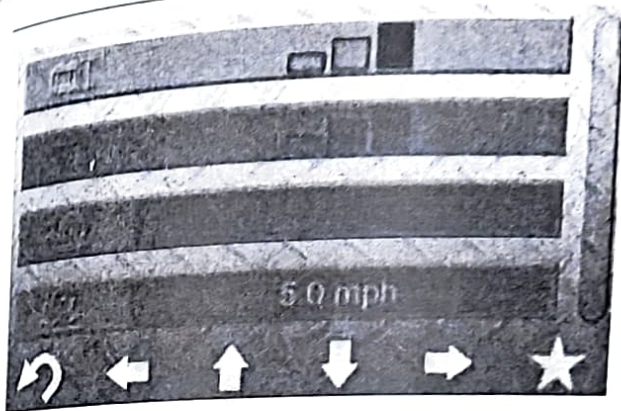

Illustration 177

g06406281

This parameter is used to change the "Drive Control Mode" which has three settings.

**Standard Mode** – 1 bar

**Intermediate Mode** – 2 bars

**Maximum Mode** – 3 bars

**Note:** Intermediate Mode (two bars) is the factory default setting.

**Note:** The Drive Control Mode setting will not return to the factory default level when the ignition key switch is turned OFF.

**Note:** The machine will start, stop, and steer more aggressively with each progressive drive control mode. Test drive the machine in an open area to become familiar with the new operating characteristics of the machine.

## Implement System Sensitivity

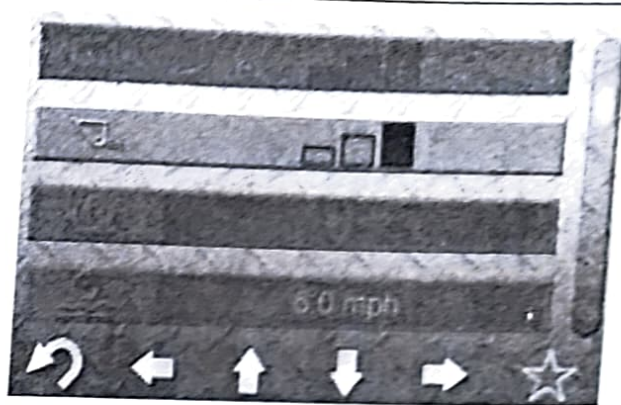

Illustration 178

g06406285

This parameter is used to change the "Implement Control Mode" which has three settings.

**Fine Control Mode** – 1 bar

**Standard Mode** – 2 bars (factory default)

**Coarse Control Mode** – three bars

**Note:** The Implement Control Mode setting will not return to a default level when the ignition switch is turned OFF.

**Note:** The machine lift arms and work tool coupler will move more aggressively with each progressive implement control mode. Test the implement functions in an open area to become familiar with the new operating characteristics of the machine.

## Creep Control



Illustration 179

g06406310

The Creep Control allows the operator to set a maximum machine travel speed at full joystick movement. Use Creep control for operations that require slow, constant speed independent of engine idle speed. The Creep Control has 20 settings.



**Slowest Setting – 1 bar**

**Default Setting – 5 bars**

**Fastest Setting – twenty bars**

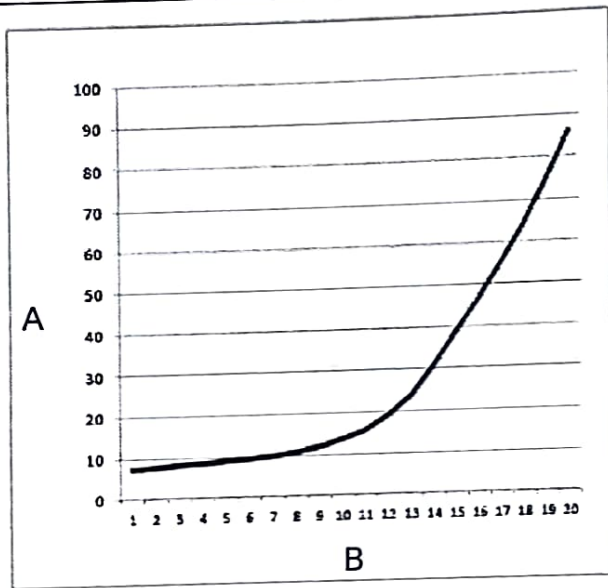

Illustration 180

g06311375

**Creep Speed Map**

(A) % of Maximum Travel Speed  
(B) Creep Speed Setting

**Note:** The machine may not travel at the lower settings depending on terrain, work tool, load, etc. If the machine does not travel at a particular setting, increment the Creep Control to progressively higher values until travel occurs.

**Note:** The optional Advanced Display module is required for Creep Control feature. See "Monitoring Screen, Creep Controller"

**Ride Control**

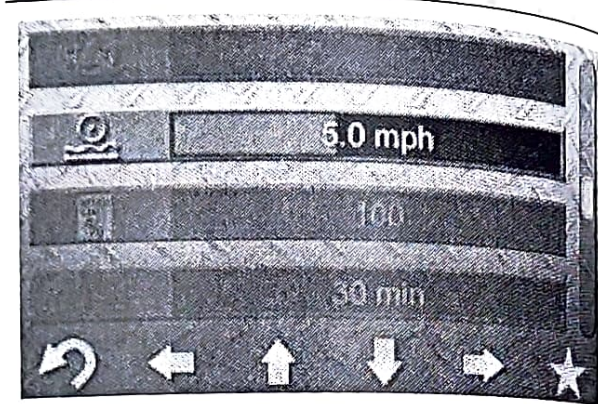

Illustration 181

g06406319

Ride Control improves the ride quality & material retention over rough terrain while carrying heavy loads by essentially using the lift cylinders as shock absorbers.

The "Ride Control Adjustment" allows the operator to change the activation speed at which the system engages when the Ride Control system is ON. Refer to Operation and Maintenance Manual, "Operator Controls, Right Side Controls". The adjustment can be made in 0.1 km/h (0.06 mph) increments.

Default activation speed is approximately 8 km/h (5 mph) for wheeled machines and 6 km/h (3.7 mph) for tracked machines.

**Steering Drift Correction**

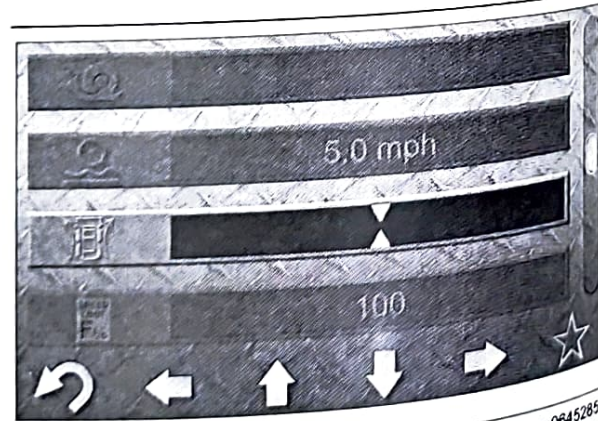

Illustration 182

g06452852

NEUTRAL (No Correction)



The "Steering Drift Correction Adjustment" allows the operator to make fine adjustments to straight-line travel to account for things like tire mismatch, drive chain tension differences, normal drive motor wear. The adjustment is offered in 10 fine increments to correct either a left or right bias. Adjust the feature left for a machine that drifts to the right. Adjust the feature right for a machine that drifts to the left.

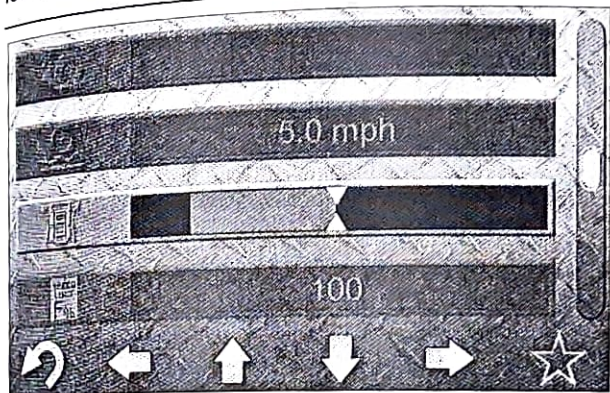

Illustration 183  
LEFT Correction

g06453166

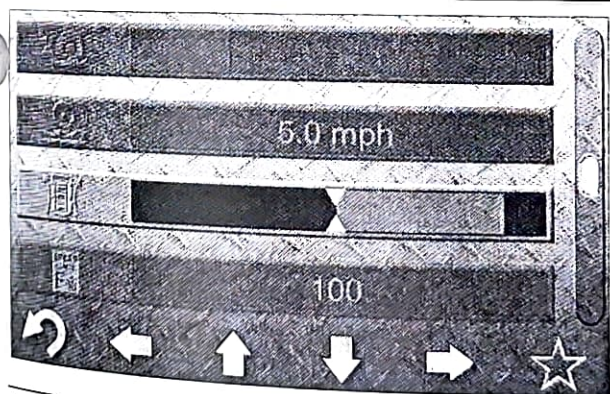

Illustration 184  
RIGHT Correction

g06453195

### Machine Speed Limit

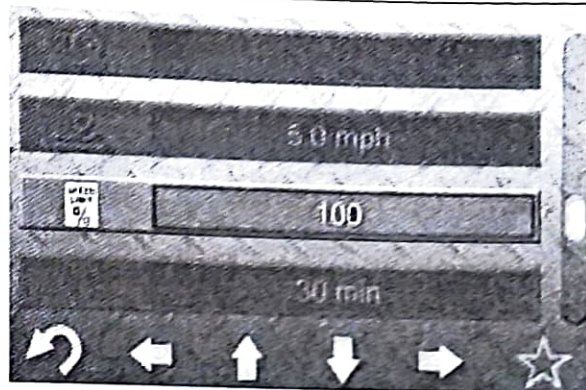

Illustration 185

g06406337

The "Machine Speed Limit Adjustment" allows the maximum travel speed to be limited. The adjustment can be made in 1% increments from 20% to 100% of the machine's maximum travel speed.

**Note:** If the Anti-Theft Security System is enabled, a user logged in under an Operator Code will only be allowed to adjust this setting up to the value stored in the Master Profile. See "Menu Screen, User Management, Master Code, and Operator Code".

**Note:** At some of the lower Speed Limit settings, 2-speed shifting may be automatically disabled.

### Reversing Fan Frequency

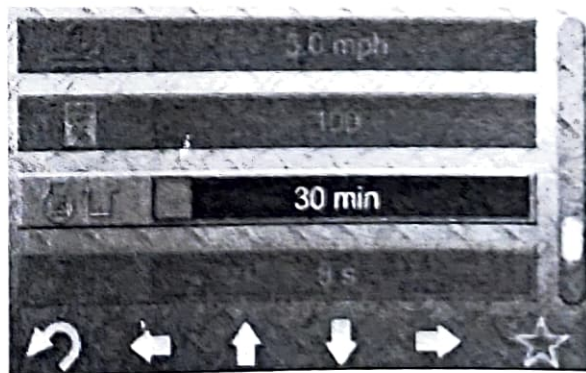

Illustration 186

g06406644

Reversing Fan Operation Interval Time is adjustable between 6 minutes and 240 minutes. This is the time between reverse cycles in the automatic mode. The lower the setting, the more frequent the reverse cycle will occur. The factory default is 30 minutes.



**Note:** The fan is more effective at cooling the machine's engine coolant and hydraulic oil in the forward direction. Running the fan in reverse too frequently may contribute to machine overheating events.

## Reversing Fan Duration



Illustration 187

g06406655

The "Reversing Fan Duration" is adjustable between 5 seconds and 12 seconds. This is the duration of each reverse cycle in the automatic mode. The fan will automatically return to the forward air flow direction after each reverse cycle. The factory default is 8 seconds.

## Display Settings



Illustration 188

g06406679

The "Display Settings" menu allows the operator to adjust several aspects regarding the look of the display. These adjustments will be stored under each operator profile. When the Anti-Theft Security System is enabled, the settings take effect each time an Operator Code is entered at the log in prompt. If the Anti-Theft Security System is not enabled, the operator settings at the time of the previous KEY OFF will remain in effect. See "Anti-Theft Security System".

## Units

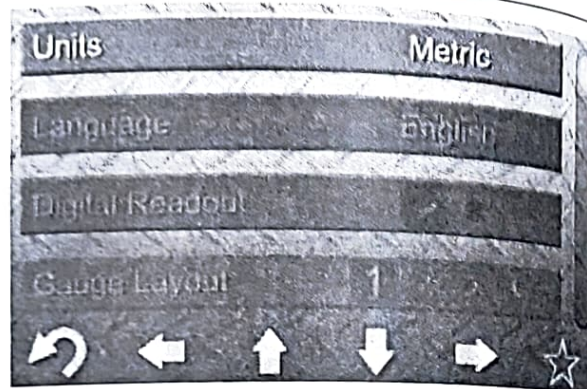

Illustration 189

g06406667

The "Units Adjustment" allows the operator to switch between Metric and English units. The factory default is English.

## Language

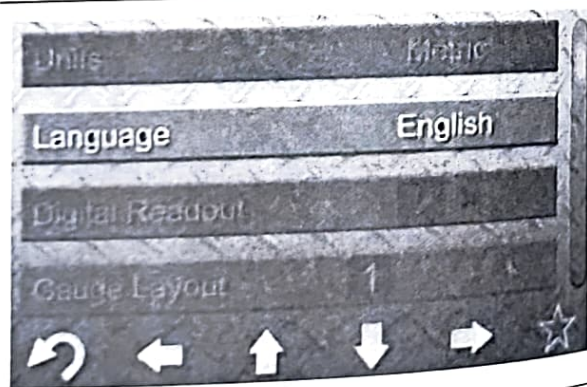

Illustration 190

g06406697

The "Language Adjustment" allows the operator to switch the display messages among six languages: English, Spanish, French, German, Portuguese, and Italian. The factory default is English.

### Digital Readout

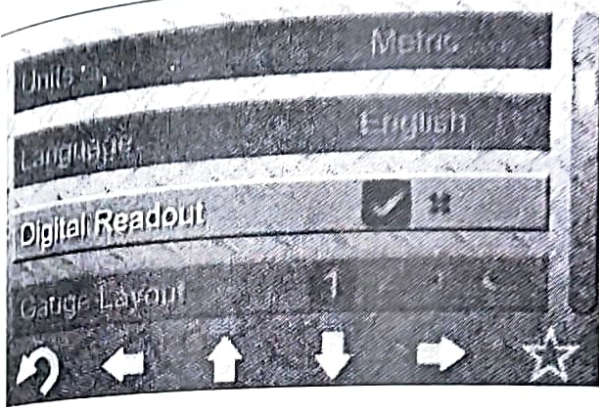

Illustration 191

g06406703

### Gauge Layout

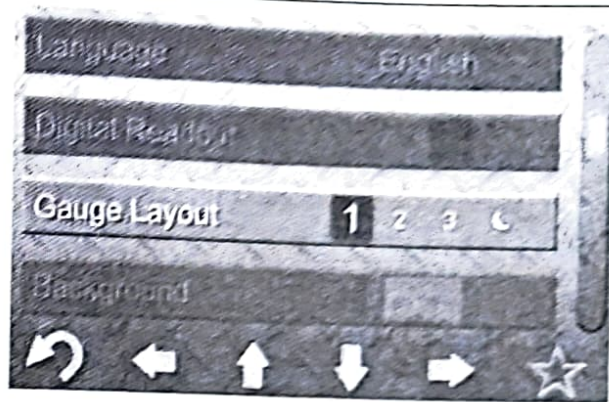

Illustration 193

g06406732

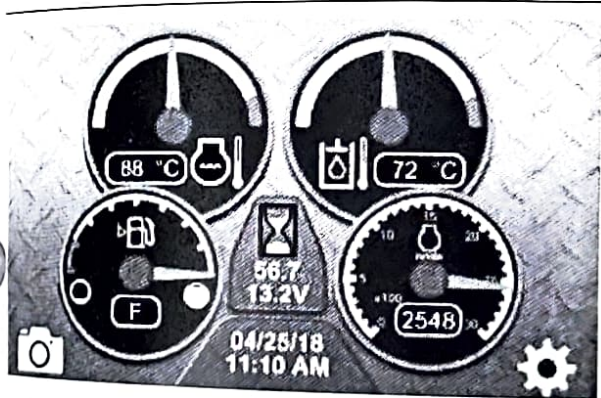

Illustration 192

g06406715

The "Digital Readout" allows the operator to either have the numerical gauge values display turned ON or OFF. The factory default is ON.



Illustration 194

g06406841

The "Gauge Layout Adjustment" allows the operator to select the Main Monitor Screen display from several available layouts. See "Monitoring Screen". The factory default is Gauge Layout 1. A unique night time scheme is represented by the "moon" icon.



**Background**

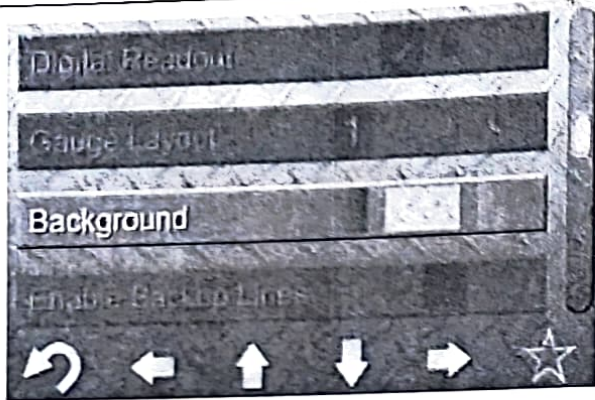

Illustration 195

g06406844

The "Background Adjustment" allows the operator to select the background color of the display from several available colors.

**Enable Backup lines**

**NOTICE**

Use of backup camera lines do not replace the basic safety precaution and procedures for machine operation in reverse.

The "Enable Backup Lines Adjustment" allows the operator to turn on reference lines when the display is in Backup Camera Mode. The Machine Width reference lines, provide an approximate indication of the backup path of the machine in a straight line. The Rear Distance reference marks provide an approximate gauge of how close objects are to the rear of the machine.

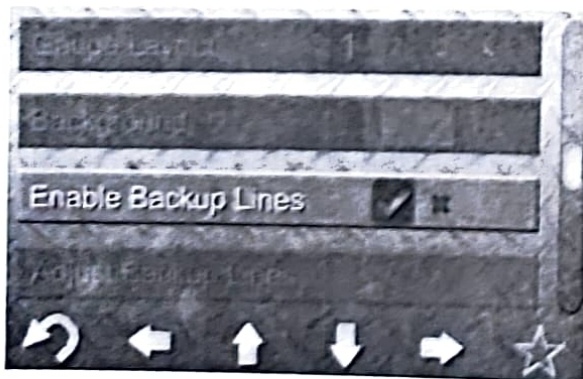

Illustration 196

g06406850

**Enable Backup Lines Setting**

Select the green "check mark" icon to enable the backup lines. Select the red "X" icon to disable the backup lines.

**Note:** The backup lines should never replace visually ensuring the area behind the machine is free of objects before traveling in reverse. The backup lines may be adjusted by the operator to better suit their preferences. See "Display Settings, Adjust Backup Lines".

**Adjust Backup Lines**

**NOTICE**

Use of backup camera lines do not replace the basic safety precaution and procedures for machine operation in reverse.

If the Backup Lines are enabled, the "Adjust Backup Lines Adjustment" screen provides the user various adjustments for both the Machine Width reference lines and Rear Distance reference marks.



Illustration 197

g06406857

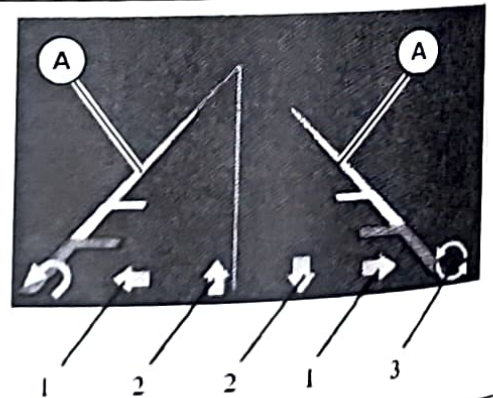

Illustration 198

**Machine Width Reference Lines Adjustment**

- (A) Machine Width Reference Lines
- (1) Left/Right Position Adjustments
- (2) Angle Adjustments
- (3) Adjustment Toggle

g06406862

The position of the Machine Width reference lines may be adjusted left and right, and the angle of each increased or decreased independently to suit the operator. Refer to 198 . It is recommended to align the Machine Width reference lines with the outside of the machine's tracks or tires and parallel to the machine. A long straight edge, tape, curb, etc. may be useful during this adjustment.

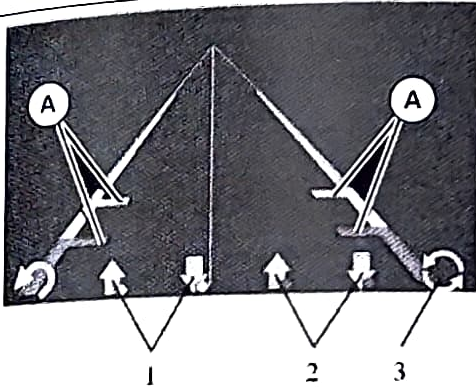

Illustration 199 g06406935

Rear Distance Reference Marks Adjustment

- (A) Rear Distance Reference Marks
- (1) Yellow Marks Adjustments
- (2) Red Marks Adjustments
- (3) Adjustment Toggle

The position of the Rear Distance reference marks may be adjusted in and out (or nearer to and farther from) with respect to the rear of the machine to suit the operator. Refer to 199 . It is recommended to set these reference lines known distances from the machine's rear door. A pair of cones, flags, paint marks, ect. may be useful during adjustment.

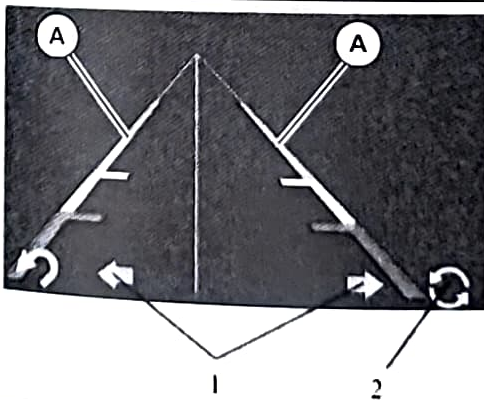

Illustration 200 g06406948

Reference Lines Skew Adjustment

- (A) Reference Lines
- (1) Left and Right Skew Adjustment
- (2) Adjustment Toggle

The left-to-right skewness of the reference lines may be adjusted to account for the off-center location of the backup camera on some models. Refer to 200 .

**Note:** The backup lines should never replace visually ensuring the area behind the machine is free of objects before traveling in reverse.

**Note:** The meaningfulness of the backup lines depends greatly on the position and angle of the backup camera, which can change over time. The backup lines should be checked or readjusted periodically. Each operator should be aware of the backup lines and understand the backup lines relative meaning on the machine.

Time Format

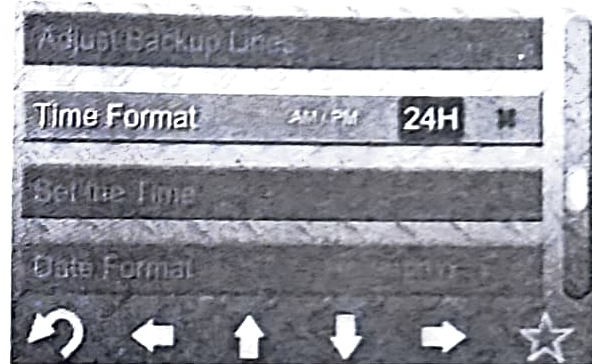

Illustration 201 g06406956

The "Time Format Adjustment" allows the operator to select a 12 hr AM/PM, 24 hr clock format, or disable the clock from appearing.



### Set the Time

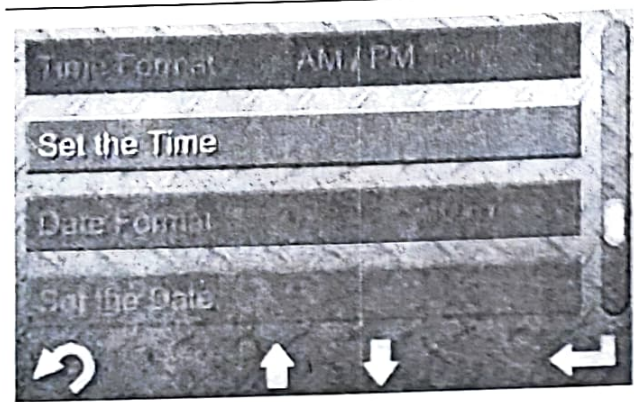

Illustration 202 g06406963

### Set the Date



Illustration 205 g06407001

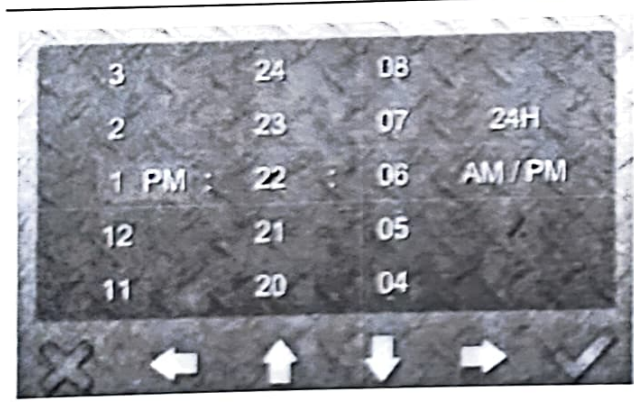

Illustration 203 g06406972

The "Set the Time Adjustment" allows the operator to set the current time of day.



Illustration 206 g06407006

The "Set the Date Adjustment" allows the operator to set the current date.

### Data Format

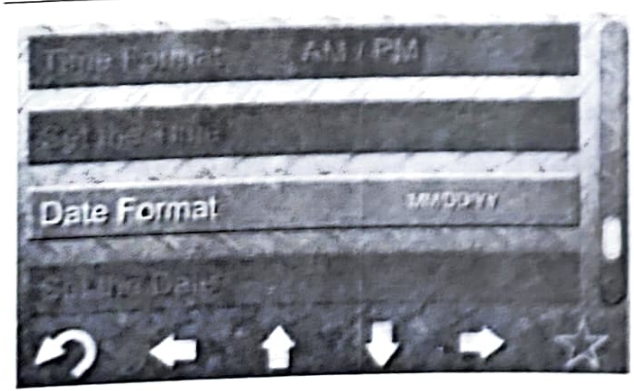

Illustration 204 g06406967

The "Date Format Adjustment" allows the operator to select between three date formats: MM/DD/YY, DD/MM/YY, or YY/MM/DD.

Set Custom Image

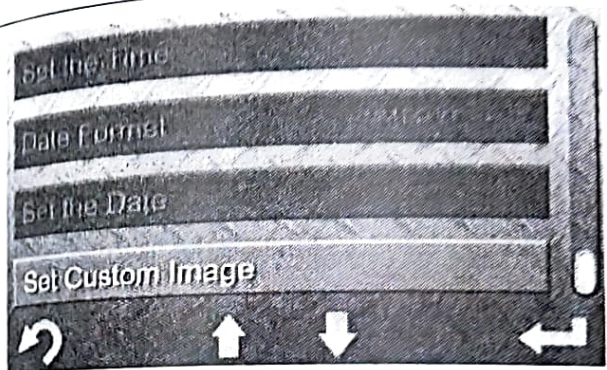

Illustration 207

g06407230

This screen allows the owner to upload a custom image that will be used as the "splash" screen image which is visible while the display boots up after each key ON. The image is loaded via a USB thumb drive plugged into the machine's USB port. The image must be either a .jpeg, .jpg, or .png file and formatted 800 x 400 for best fit. See "Operator Controls, Left Side Controls, Power Supply Port".

The available grace periods are 15 min, 30 min, 1 hr, 2 hrs, and 4 hrs. The factory default is 30 min. A user logged in via a Master Code may select any of the available grace periods. A user logged in via an Operator Code will only be allowed to adjust this value up to the grace period stored in the Master Profile. See "Anti-Theft Security System", "User Management, Master Code" and "User Management, Operator Code" in this section.

Dealer Name

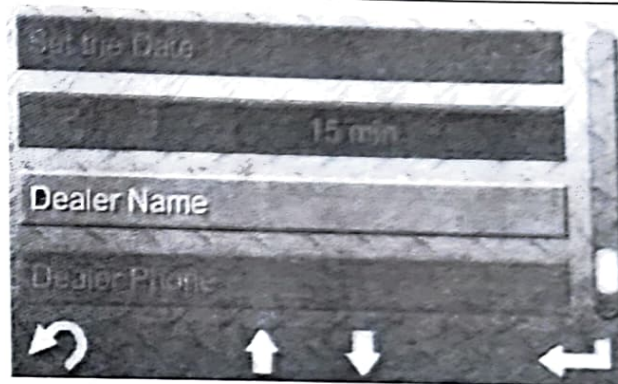

Illustration 209

g06407244

The "Dealer Name" setting allows the owner to enter a Dealer Name or any other combination of text and numerals. The entry is displayed momentarily on the Welcome Screen each time the machine is "KEYED ON". This adjustment requires a Master Code to access once a Master Code has been established. An Operator Code will not allow access to this adjustment. See "User Management, Master Code, and Operator Code".

Security Grace Period

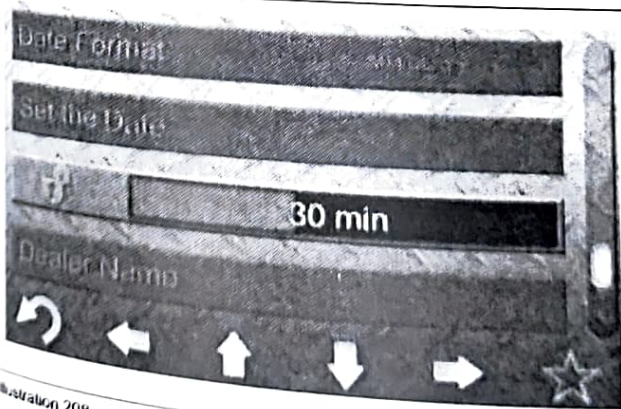

Illustration 208

g06407237

If Machine Security is enabled, the "Security Grace Period Adjustment" allows the user to select from several choices of grace periods, which will determine how long the machine remains unsecured once Keyed OFF. The grace period timer begins at Key OFF and during the grace period, the machine will not require reentry of a PIN when Keyed ON again.



## Dealer Phone

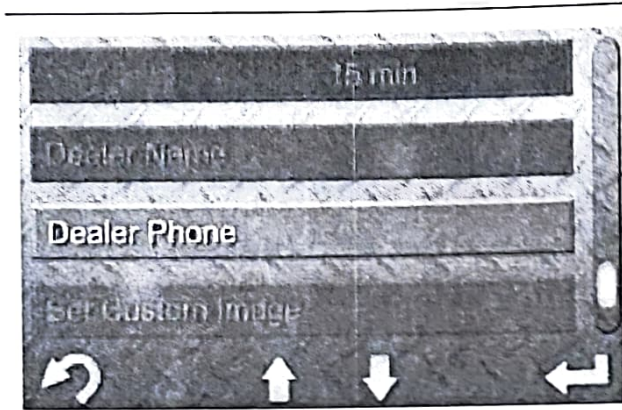

Illustration 210

g06407264

The "Dealer Phone" setting allows the owner to enter a Dealer Phone Number or any other combination of numerals. The entry is displayed momentarily on the Welcome Screen each time the machine is "KEYED ON". This adjustment requires a Master Code to access once a Master Code has been established. An Operator Code will not allow access to this adjustment. See "User Management, Master Code, and Operator Code".

## Job Clock Menu



Illustration 211

g06407272

This screen allows the operator to start, stop, and reset a job clock. The job clock saves over the key cycle and starts up automatically on the next startup or operator login. A separate job clock is stored under each operator profile.



Illustration 212

g06407297

## Information Screen

This screen will display various system-related information including the following items:

- Machine Serial Number
- Engine ECU hardware and software part number
- Advanced Display hardware and software part number

This information can be shared with the Cat Dealer to ensure that the machine has the latest software installed to take advantage of any improvements developed since the machine was manufactured.

## Service Menu

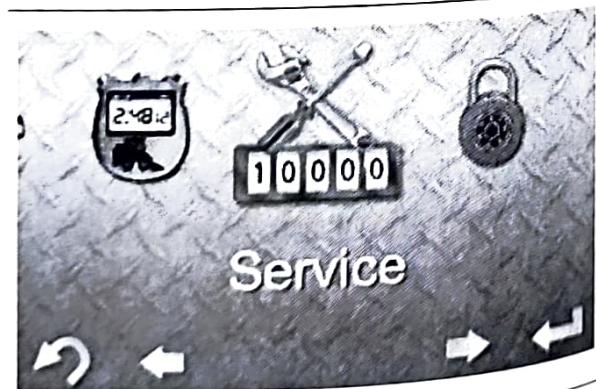

Illustration 213

g06407319

The "Service Menu" is composed of several sub menus which allow the user to access valuable information about the machine. These sub menus are described below:



## Diagnostics Sub Menu

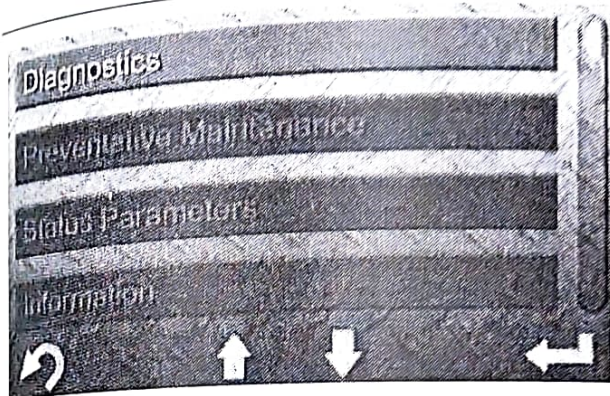

Illustration 214

g06407368

The screens within this sub menu allow the user to view active (currently occurring) or logged (having occurred; may be active or no longer active) machine condition warnings.

### Diagnostics & Events

Diagnostic Codes indicate that a sensor or hardware component is currently faulted (Active Diagnostic), or has faulted previously (Logged Diagnostic) and machine functionality may be impacted.

Event Codes indicate that a sensor is detecting (Active Event), or has previously detected (Logged Event) a condition that could result in machine damage if not corrected as soon as possible.

There are three levels of Diagnostic and Event Codes indicating the relative severity of the warning. The pop-up screens will change color depending on the warning level.

**Level 1** – A condition is trending in a direction that may indicate that damage could occur if the operating condition persists. There is no pop-up screen displayed for this level but the Driver Alert Indicator will illuminate continuously. The diagnostic or event code will be shown on a green background in these screens. The operator should stop the machine at the earliest convenience and investigate the cause. If no additional alert indicators are illuminated, contact your Cat dealer or refer to the service manual for more information. See "Alert Indicators".

**Level 2** – A condition has been detected which could result in component damage. A yellow pop-up screen will be displayed providing information on the condition. The Driver Alert will be flashing but no cab alarm will be audible. The diagnostic or event code will be shown on a yellow background in these screens. The operator should change operation or perform the indicated maintenance being displayed. See "Alert Indicators".

**Level 3** – A condition has been detected that is likely to result in severe component damage and could result in injury. A red pop-up screen will be displayed providing information on the condition. The Driver Alert will be flashing and the cab alarm will be audible. The diagnostic or event code will be shown on a red background in these screens. The operator should stop the machine immediately and perform the indicated maintenance being displayed or contact your Cat dealer. See "Alert Indicators".

## Preventative Maintenance Sub Menu

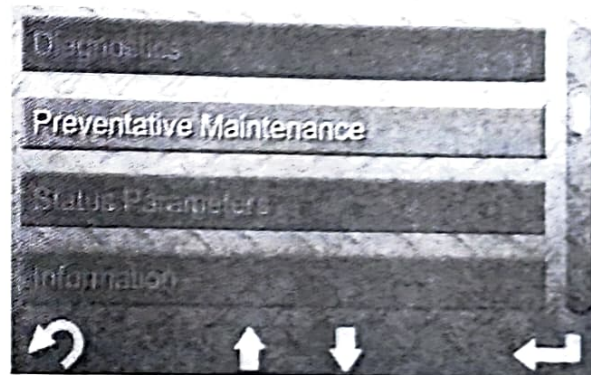

Illustration 215

g06407404

The "Preventative Maintenance" interval screens are pop-up reminders to indicate that a scheduled maintenance interval is approaching. These intervals are based on machine hours and can be reset by the owner after the maintenance is performed. The screens will provide the operator several pieces of information including:

**Maintenance Item** – The item to be checked or changed

**Interval Hours** – The service interval or machine hours between repeated services.

**Hours Remaining** – The number of machine hours remaining before the service item becomes past due.

**Activation Hours** – The actual value of the machine hours when the service is due

**Reset** – Select this icon to reset the maintenance interval after a service has been performed.



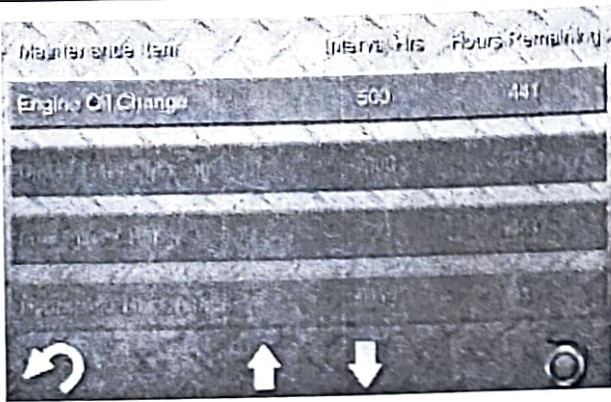

Illustration 216

g06407445

**Note:** Only the Master account can reset the maintenance interval.

### Status Parameters Sub Menu

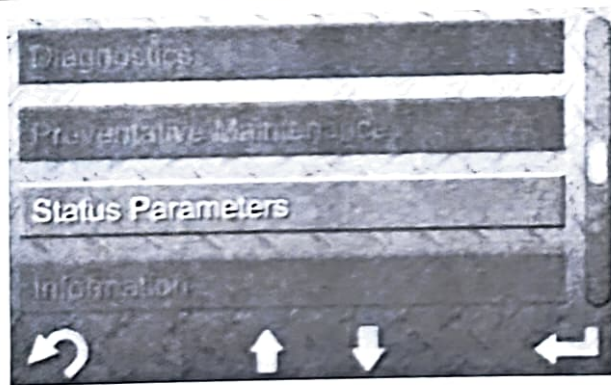

Illustration 217

g06407466

The "Status Parameters" screen shows the status of some of the most important machine parameters such as throttle position, engine speed, joystick position, battery voltage, drive motor speed. The parameter status information may be useful for basic troubleshooting.

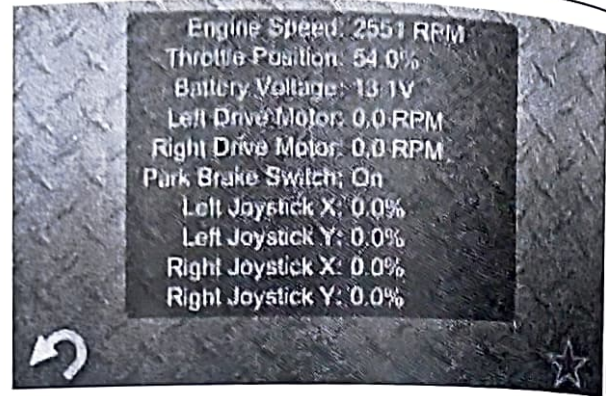

Illustration 218

g06407473

### Information Sub Menu

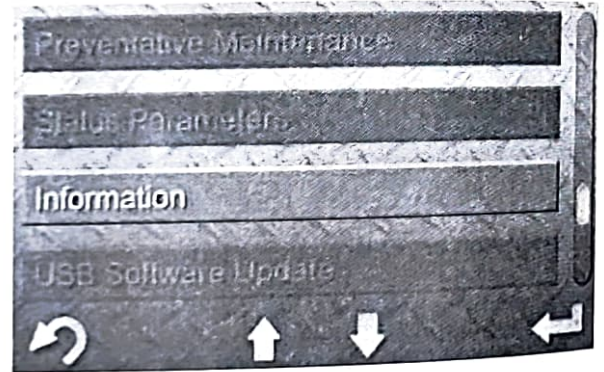

Illustration 219

g06407485

This screen will display various system-related information including the following items:

- Machine Serial Number
- Engine ECU hardware and software part number
- Advanced Display hardware and software part number

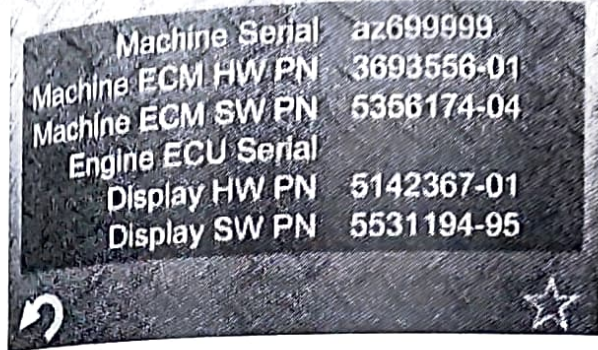

Illustration 220

g06407487

This information can be shared with the Cat Dealer to ensure that the machine has the latest software installed to take advantage of any improvements developed since the machine was manufactured.

### Service Screens

The service menu is composed of the following screens.

**Status Parameters** – Allows for viewing the status of some of the most important machine parameters such as throttle position, engine speed, joystick position, battery voltage, drive motor speed. The parameter status information may be useful for basic troubleshooting.

**USB Software Update** – Allows for the Cat dealer to service the Advanced Display's software as needed.

**Set Custom Image** – Allows the owner to upload a custom image that will be used as the "splash" screen image which is visible while the display boots up after each key ON. The image is loaded via a USB thumb drive plugged into the machine's USB port. The image must be either a .jpeg, .jpg, or .png file and formatted 800 x 400 for best fit. See "Operator Controls, Left Side Controls, Power Supply Port".

### USB Software Update Sub Menu

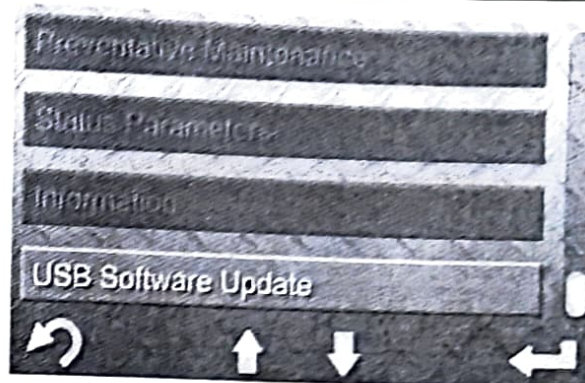

Illustration 221

g06407494

The "USB Software Update" screen allows for the Cat dealer to service the Advanced Display's software as needed.

### User Management



Illustration 222

g06407501

On machines equipped with the latest Advanced Display software, security may be enabled by the user under this menu. Security may always be enabled by the Cat dealer regardless of machine configuration. See "Anti-Theft Security System" in this section.



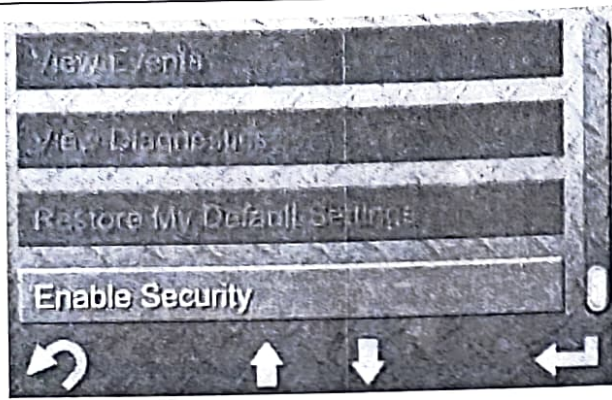

Illustration 223

g06407509

If security has been enabled, the User Management menu screens allow the addition, deletion, and editing of operator profiles as well the viewing and re-setting of machine or operator-specific information. There are two types of profiles; the Master Profile, which is accessed by entry of the Master Code during the log on sequence, and one or more Operator Profiles, which are accessed by entry of an Operator Code. Entry of either a Master Code or an Operator Code will yield specific rights regarding the viewing & editing capability of information.

### Master Code



Illustration 224

g06407516

The default Master Code is "1111" and is established when the Anti-Theft Security System is first enabled. This code should be changed by the owner as soon as possible as a security best practice. Options available in the User Management menu while logged in under the Master Code are as follows:

**View** – The master operator can view and edit the following information for each operator profile.

- An operator profile name up to 15 ASCII characters

- The total machine hours accrued while the operator has been logged in.
- Total Fuel used while the operator has been logged in (electronic engines only).
- The Total Machine Hours and Total Fuel Used may be reset independently.
- The Event and Diagnostic Codes that have occurred while the operator has been logged in.

**Add Operator** – Allows the Master Operator to add an operator profile and set the Operator Name and Operator Code

**Delete Operator** – Allows the Master Operator to delete an operator profile. The Master Operator cannot be deleted.

**Edit Operator** – Allows the Master Operator to Change the current Operator Name and Operator Code.

**Set the Time and Date** – Allows the Master Operator to set the current time and date.

**Restore Default Settings** – Allows the Master Operator to restore the factory machine settings of either the Master Profile (Restore My Default Settings), or the Master Profile, and all Operator Profiles (Restore All Default Settings).

**Note:** The settings that exist in the Master Profile for Security Grace Period, and machine Speed Limit will be the maximum allowable values for all Operator Profiles. A user logged in via an Operator Code will only be allowed to adjust these settings between the factory allowable minimum value and the value in the Master Profile. See "Operator Settings, Speed Limit" and "Operator Settings, Security Grace Period" in this section.



### Operator Code



Illustration 225 g06407523

Operator Profiles are only available for creation while logged in under the Master Code. During creation of an Operator Profile, a unique Operator Code should be chosen. Options available in the User Management menu while logged in under an Operator Code are as follows:

**View** – The Operator can view the following information for the currently logged in operator.

- The name of the current operator
- The total machine hours accrued while the operator has been logged in.
- Total Fuel used while the operator has been logged in (electronic engines only).
- The Display Event and Diagnostic Codes that have occurred while the operator has been logged in

**Edit Operator** – Allows the Operator to Change the current Operator Name and Operator Code.

**Note:** When switching between profiles, the Security Grace Period must be allowed to expire before the next key ON event will prompt for entry of a log-on code. The grace period set by the current profile may be ignored at key OFF by selecting the soft key under the green check mark symbol. This selection will secure the machine within about 30 seconds, allowing for faster switching between profiles.



Illustration 226 g06407535

### Key Off "Lock Out" Prompt

**Red "X" or No Action** – Grace Period Applies

**Green Checkmark** – Grace Period Overridden

### Anti-Theft Security System

This feature if enabled requires an operator to enter a valid Operator Code before allowing the engine to crank. There is one Master Code and up to 50 unique Operator Codes. Entry of a valid code will also automatically load Operator Settings that have been previously saved under the current operator profile. See "Menu Screen, Operator Settings". At key "ON", if the security system is enabled and locked, the operator will be prompted to enter their unique 4-digit to 6-digit Operator Code. Enter the pin code using the soft keys. Press the appropriate key once for the odd numeral (1, 3, 5, 7, or 9). Press the key twice quickly for the even numerals (2, 4, 6, 8 or 0). After the code is entered, press the "enter" key to submit the code. If the code is incorrect, the Display Window will show "Invalid Code" and another attempt can be made. If the code is correct, the Welcome Operator Screen will be displayed and the Operator Settings loaded from the operator profile. The key switch may be moved to the "START" position to start the machine.

**Note:** For security purposes, in the event an incorrect PIN is entered five times consecutively, the system will lock itself down for 15 minutes, during which period even a correct PIN will not allow the engine to crank. After the 15 minute lockdown period, entry of a correct PIN will unlock the system as usual.



**Note:** On machines equipped with the latest Advanced Display software, security may be enabled by the user under the "User Management" sub menu. Security may always be enabled by the Cat dealer regardless of machine configuration.

## Backup Camera Mode

### NOTICE

Use of backup camera lines do not replace the basic safety precaution and procedures for machine operation in reverse.

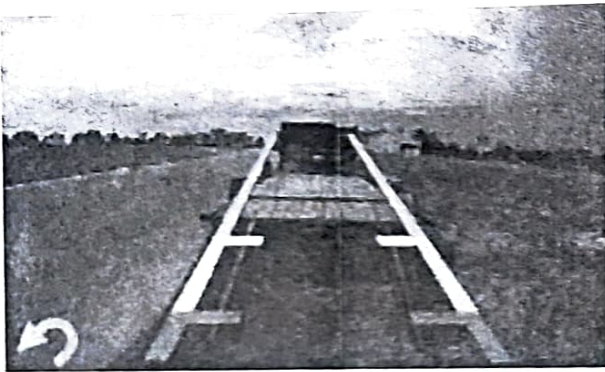

Illustration 227

g06362372

The Camera Screen shows the input from a connected camera if equipped. The display will automatically switch to the Camera Screen anytime the machine is commanded to travel in reverse. Once the reverse travel command is no longer applied, the screen will automatically revert to the prior screen.

The camera display may also be activated from the monitoring screen at any time by pressing the left most soft key which will depict a camera symbol above it while the camera display is not active. Pressing this button again will return the user to the monitoring screen.

**Note:** The display will momentarily display the camera view each time the parking brake is released.

**Note:** The backup lines should never replace visually ensuring the area behind the machine is free of objects before traveling in reverse. The backup lines may be adjusted by the operator to better suit their preferences. See "Display Settings, Adjust Backup Lines".

## Other Features in the Cab

### Interlock Control

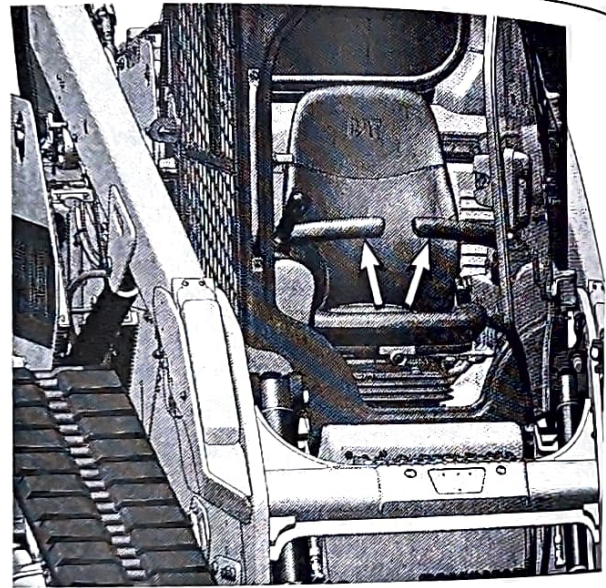

Illustration 228

g06353312

#### Armrests

**Interlock Control** – Move the armrests to the RAISED position to lock out the hydraulic controls.

**Note:** When the armrests are moved to the RAISED position, the parking brake will engage. Move the armrests to the LOWERED position and push the switch for the parking brake to activate the hydraulic controls.

**Note:** When you start the engine, the parking brake must be disengaged for the hydraulic controls to be activated. If the armrests are raised and lowered during operation, disengage the parking brake for the hydraulic controls to be activated.

## Engine Speed Control

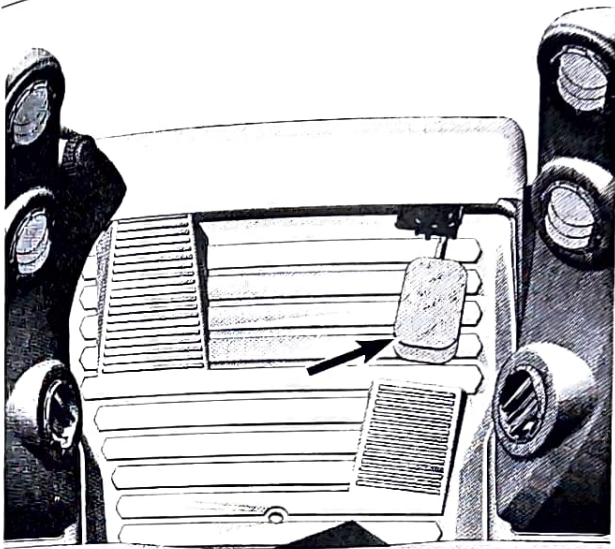

Illustration 229

g06353347



**Engine Speed Control – Push down on the Engine Speed Control Pedal to increase engine speed. Release the**

**Engine Speed Control Pedal to decrease engine speed. The Engine Speed Control Pedal will return to the setting of the engine speed control knob.**

**Note:** If the Engine Speed Control Knob is fully clockwise, the Engine Speed Control Pedal will lower engine RPM.

**Note:** The deceleration function will not lower the RPM to low idle. Do not use this function as a braking function.

**Note:** There are several features that may impact the low idle of the machine. Refer to Operation and Maintenance Manual, "Engine Starting" for more detailed information.

## Suspension Seat

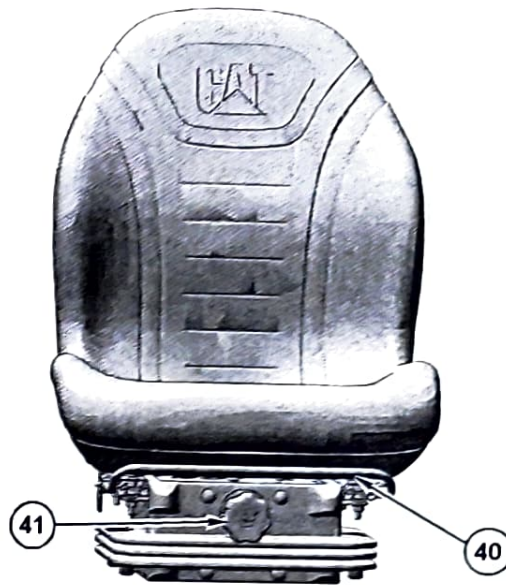

Illustration 230

g06353392

(40) Fore/Aft Adjustment  
(41) Adjustment for the suspension

**Fore/Aft lever (40) – Move the lever to adjust the seat.**

**Height (41) – Turn the knob to adjust the suspension of the seat. Turn the knob clockwise for a heavier person. Turn the knob counterclockwise for a lighter person.**

## Standard Seat

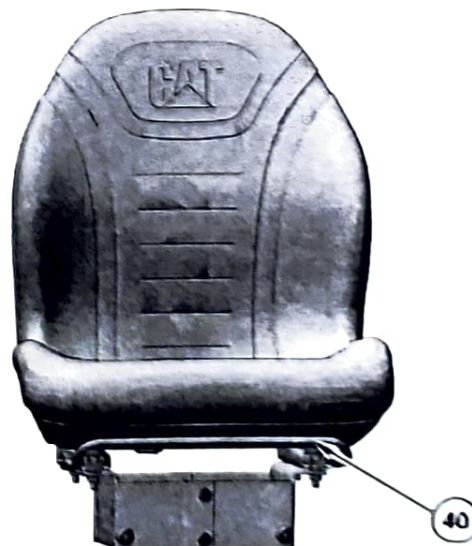

Illustration 231

g06353400

(40) Fore/Aft Adjustment



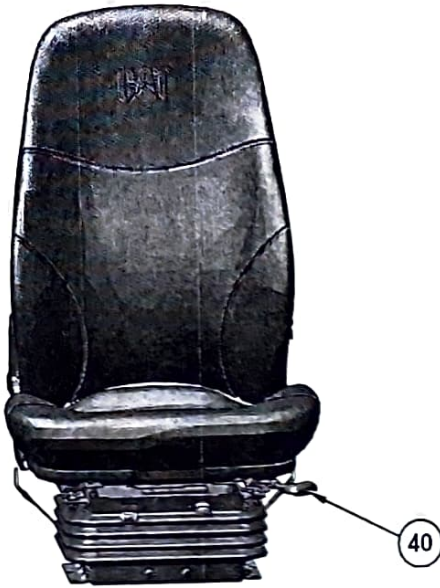

Illustration 232

g06353409

(40) Fore/Aft Adjustment

### Air Suspension Seat

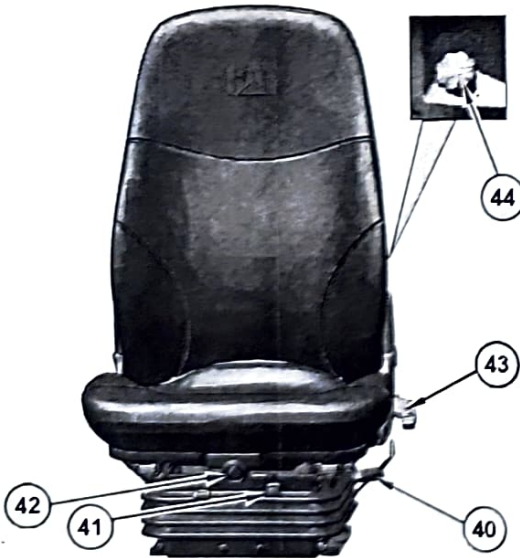

Illustration 233

g06353444

- (40) Fore/Aft Adjustment
- (41) Adjustment for the suspension
- (42) Heat (refer to Seat Heater Controls)
- (43) Seat Angle (Incline/Recline)
- (44) Lumbar



### Seat Adjustment

Push in the knob (41) to increase the stiffness of the suspension. Pull the knob to decrease the stiffness of the suspension. The button (42) on the front will turn on heat. The lever on the left side (43) will incline and decline the seat. To adjust the lumbar, (44) turn the knob on left rear of seat.

**Note:** The engine start switch key must be in the ON position to increase the stiffness of the seat.

### Seat Heater Controls



Illustration 234

g06353516

### WARNING

Heat-induced burns can occur when some people use a seat heater. Do not use the seat heater if you have a reduced ability to sense temperature changes, a reduced ability to feel pain, or have sensitive skin.

The control switch (42) for the seat heater is located near the middle of the seat just below the seat cushion.

Press the top of the switch to turn ON the seat heater. The switch's lamp should illuminate indicating the switch is in the ON position. Press the bottom of the switch to turn OFF the seat heater.

**Note:** If the switch is in the ON position the seat heater will work even if the switch's lamp does not illuminate. Have a failed lamp replaced as soon as possible.

### Armbar and Controls - Adjust

The armbar and joystick assemblies may be adjusted to improve operator comfort.

## Cab-Mounted Controls for Mechanical Suspension Seat

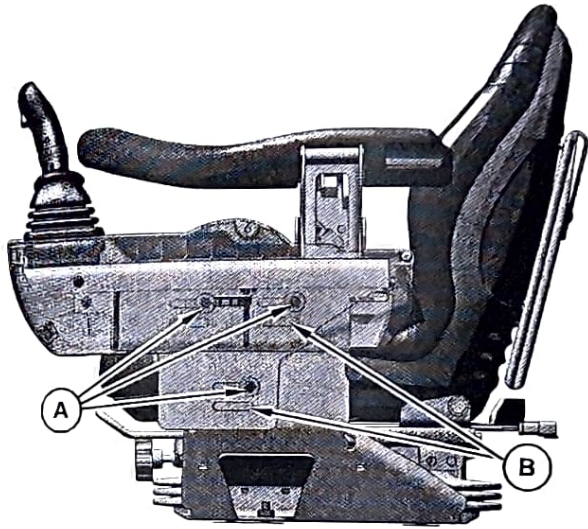

Illustration 235  
Mechanical Suspension Seat

g06353534

1. Remove the three locknuts and washers (A).
2. Raise the controls bracket up to the alternate mounting slots (B).
3. Adjust for / aft as desired.
4. Reinstall the washers and locknuts (A).
5. Torque to  $15 \pm 3 \text{ N}\cdot\text{m}$  ( $11 \pm 2 \text{ lb ft}$ ).

## Seat-Mounted Controls for Air Ride Suspension Seat

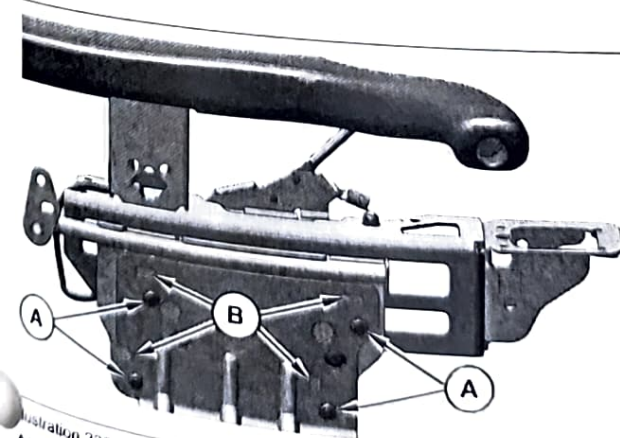

Illustration 236  
Air Ride Suspension Seat

g06353580

1. Remove the three locknuts and washers (A).

2. Raise the controls bracket up to the alternate mounting slots (B).
3. Adjust fore/aft as desired.
4. Reinstall the washers and locknuts (A).

## Joystick Controls

There are three possible joystick control patterns depending on how the machine is equipped. Each control pattern will affect movement of the work tool and movement of the machine. Each pattern will be discussed in a separate section below.

**1. Cat Control Pattern** – Default control pattern for machines that are NOT equipped with either the optional Selectable Control Pattern feature or the Dedicated H-Control Pattern feature. Option "1" control pattern for machines that are equipped with the Selectable Control Pattern feature. Refer to Operation and Maintenance Manual, "Operator Controls, Left Side Controls, Selectable Pattern Control Switch".

**2. H-Control Pattern** – Default control pattern for machines that are equipped with the optional Dedicated H-Control Pattern feature. Option "2" control pattern for machines that are equipped with the Selectable Control Pattern feature. Refer to Operation and Maintenance Manual, "Operator Controls, Left Side Controls, Selectable Pattern Control Switch".

**3. Hand and Foot Control Pattern** – Default control pattern for machines that are equipped with the optional Electrohydraulic (EH) Hand and Foot Controls.

Refer to the section Operation and Maintenance Manual, "Auxiliary Hydraulic Controls" following the three control patterns for instructions about the Auxiliary Hydraulic System.

**Note:** Your machine may not be equipped with all the controls described in this topic.



## Cat Control Pattern: Left-Hand Joystick

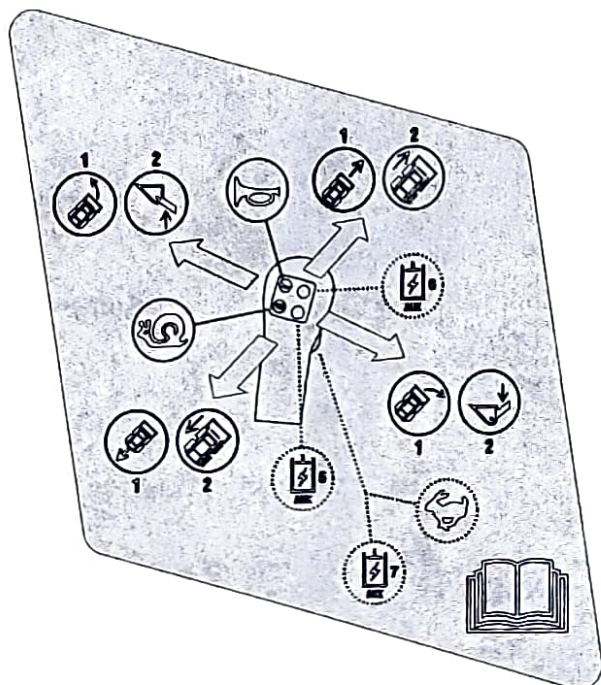

Illustration 237

g06591545

Instruction Film for the Left-Hand Joystick

### Forward



**Forward Travel** – Push the joystick forward to travel forward.

### Backward



**Backward Travel** – Pull back on the joystick to travel in reverse.

### Right Turn



**Right Turn** – Move the joystick to the right to turn the machine to the right.

### Left Turn



**Left Turn** – Move the joystick to the left to turn the machine to the left.

### Horn



**Horn** – Press the switch to sound the horn. Use the horn to alert personnel.

## Two Speed Control



**Two-Speed** – Press the trigger and release the trigger on the front of the left-hand joystick to activate rabbit mode. To activate rabbit mode, the Multifunction Switch must also be in the two-speed position. Refer to “Multifunction Switch for the Left-Hand Trigger (3)” above for instructions about the switch.

**Note:** Keep the work tool close to the ground when you travel in rabbit mode. This method will maximize the stability of the machine.

## Creep Control

The Creep Control allows the operator to select a maximum machine travel speed at full joystick movement. Use creep control for operations that require slow, constant speed independent of engine idle speed.



**Creep Control** – Press the bottom left-hand joystick to turn on the creep control feature. Creep mode will be engaged the next time the joystick passes through NEUTRAL position, either during a change of direction or travel initiation from a stopped position. Press the bottom left-hand button on the left-hand joystick to turn off the creep control. Creep mode will be disengaged the next the joystick passes through the NEUTRAL position, either during a change of direction or stopping the machine.

Refer to “Right Side Controls (Alternate), Creep Control” for detailed information about the creep speed control.

# Cat Control Pattern: Right-Hand Joystick

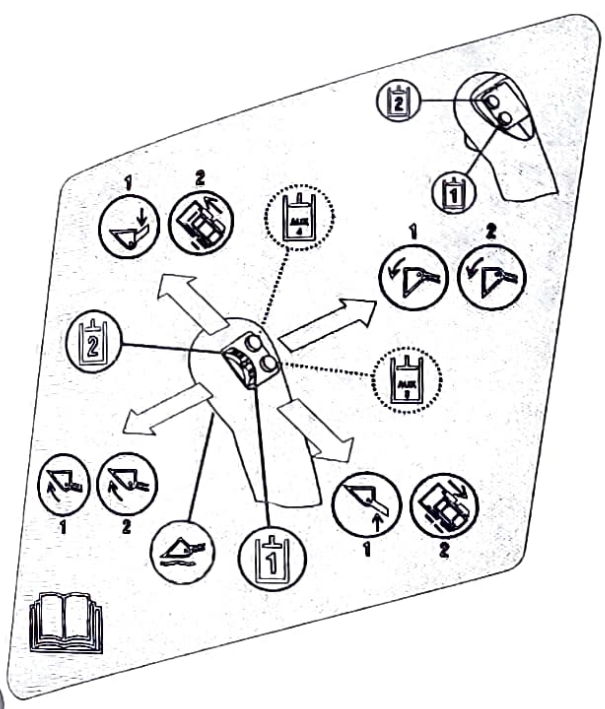







Illustration 238  
Instruction Film for the Right-Hand Joystick  
g06591582

- Lower**  
 **Lower – Push the joystick forward to lower the work tool.**
- Dump**  
 **Dump – Move the joystick to the right to tilt the work tool downward.**
- Raise**  
 **Raise – Pull the joystick backward to raise the work tool.**
- Tilt Back**  
 **Tilt Back – Move the joystick to the left to tilt the work tool upward.**
- Float**  
 **Float – Float allows the work tool to follow the contour of the ground.**

The following conditions will activate the float function on the machine.

Move the joystick to the LOWER position and press the trigger. Float is activated. You may now release the trigger.

Once the float function is engaged, the joystick can be returned to the neutral position without affecting the float function. Float will remain engaged until the trigger on the right-hand joystick is pressed again. The float function will disengage also when the bucket is raised or when the bucket is lowered by a command greater than approximately 15% of full joystick range.

### Auxiliary Shake Out Mode

Auxiliary Shake Out mode is an aggressive movement of the work tool to dislodge wet or sticky material.

Move the right-hand joystick thumb wheel over the NEUTRAL position three times within a 2 second period to activate Auxiliary Shake Out mode. Auxiliary Shake Out mode will remain engaged while the thumb wheel is moved back and forth over the NEUTRAL position. Normal auxiliary control mode will return when the movement of the thumb wheel is discontinued.

### Bucket Shake Out Mode

Bucket Shake Out mode is an aggressive movement of the work tool to dislodge wet or sticky material.

Move the Right-Hand Joystick over the NEUTRAL position three times within a 2 second period to activate Bucket Shake Out mode. Bucket Shake Out mode will remain engaged while the Right-Hand Joystick is moved left and right over the NEUTRAL position. Normal bucket control mode will return when the movement of the Right-Hand Joystick is discontinued.



## H-Control Pattern: Left-Hand Joystick

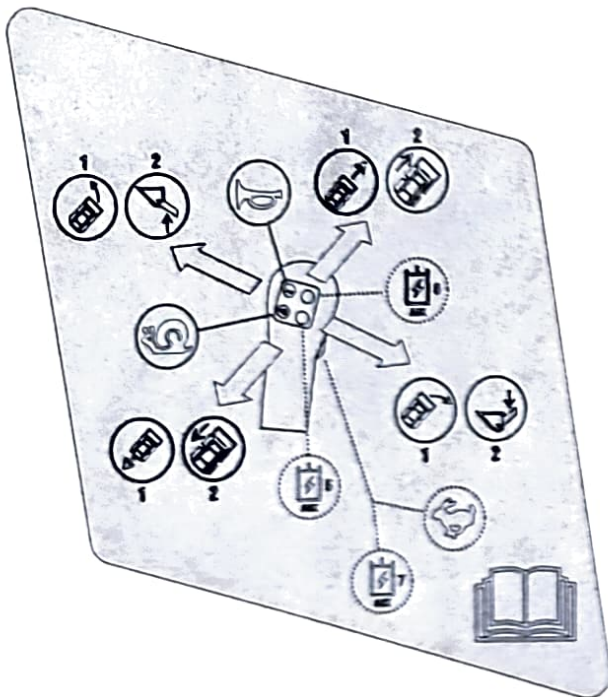

Illustration 239

g06591545

### Instruction Film for the Left-Hand Joystick

#### Forward Drive



**Forward** – Push the left-hand joystick forward to move the left side of the machine forward.

Push both joysticks forward equally to move the machine in a straight line.

#### Reverse Drive



**Reverse** – Pull the left-hand joystick backward to move the left side of the machine backward.

Pull both joysticks backward equally to move the machine backward in a straight line.

#### Right Turn

Push the left joystick forward to turn the machine to the right.

Push the left joystick forward and pull the right joystick backward to turn the machine rapidly to the right.

#### Horn



**Horn** – Press the switch to sound the horn. Use the horn to alert personnel.

#### Two Speed Control



**Two-Speed** – Press the trigger and release the trigger on the front of the left-hand joystick to activate rabbit mode. To activate rabbit mode, the Multifunction Switch must also be in the two-speed position. Refer to "Multifunction Switch for the Left-Hand Trigger (3)" above for instructions about the switch.

**Note:** Keep the work tool close to the ground when you travel in rabbit mode. This method will maximize the stability of the machine.

#### Lower



**Lower** – Move the joystick to the right to lower the work tool.

#### Raise



**Raise** – Move the joystick to the left to raise the work tool.

#### Creep Control

The Creep Control allows the operator to select a maximum machine travel speed at full joystick movement. Use creep control for operations that require slow, constant speed independent of engine idle speed.



**Creep Control** – To activate the creep control, stop the machine and return the joysticks to the NEUTRAL position. Press the bottom left-hand switch on the left-hand joystick to turn on the creep control. To deactivate the creep control, stop the machine and return the joysticks to the NEUTRAL position. Press the bottom left-hand switch on the left-hand joystick to turn off the creep control.

Refer to "Right Side Controls (Alternate), Creep Control" for detailed information about the creep speed control.

# H-Control Pattern: Right-Hand Joystick

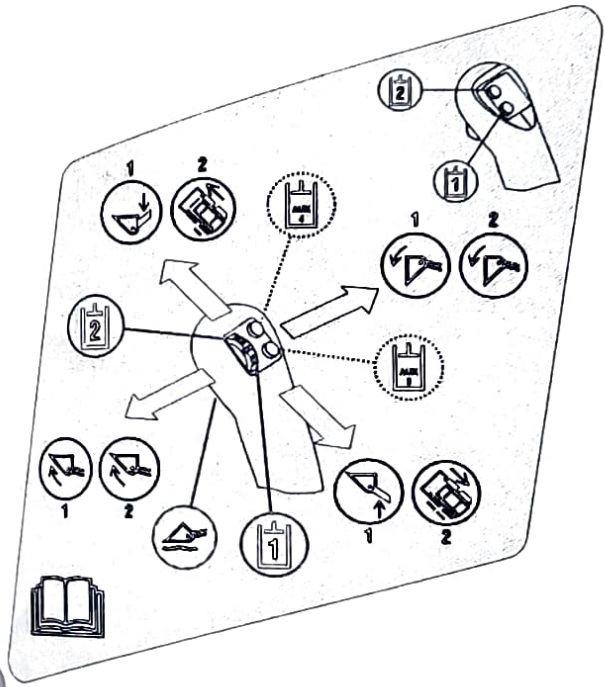



Illustration 240 g06591582

## Instruction Film for the Right-Hand Joystick

### Forward Drive

 **Forward** – Push the right-hand joystick forward to move the right side of the machine forward.

Push both joysticks forward equally to move the machine forward in a straight line.

### Reverse Drive

 **Reverse** – Pull the right-hand joystick backward to move the right side of the machine backward.

Pull both joysticks backward equally to move the machine backward in a straight line.

### Left Turn

Push the right joystick forward to turn the machine to the left

Push the right joystick forward and pull the left joystick backward to turn the machine rapidly to the left

### Dump

 **Dump** – Move the joystick to the right to tilt the work tool downward.

### Tilt Back

 **Tilt Back** – Move the joystick to the left to tilt the work tool upward.

### Float

 **Float** – Float allows the work tool to follow the contour of the ground.

The following conditions will activate the float function on the machine.

Move the joystick to the LOWER position and press the trigger on the right-hand joystick. Float is activated. You may now release the trigger.

Once the float function is engaged, the joystick can be returned to the neutral position without affecting the float function. Float will remain engaged until the trigger on the right-hand joystick is pressed again. The float function will disengage also when the bucket is raised or when the bucket is lowered by a command greater than approximately 15% of full joystick range.

### Auxiliary Shake Out Mode

Auxiliary Shake Out mode is an aggressive movement of the work tool to dislodge wet or sticky material.

Move the right-hand joystick thumb wheel over the NEUTRAL position three times within a 2 second period to activate Auxiliary Shake Out mode. Auxiliary Shake Out mode will remain engaged while the thumb wheel is moved back and forth over the NEUTRAL position. Normal auxiliary control mode will return when the movement of the thumb wheel is discontinued.

### Bucket Shake Out Mode

Bucket Shake Out mode is an aggressive movement of the work tool to dislodge wet or sticky material.

Move the Right-Hand Joystick over the NEUTRAL position three times within a 2 second period to activate Bucket Shake Out mode. Bucket Shake Out mode will remain engaged while the Right-Hand Joystick is moved left and right over the NEUTRAL position. Normal bucket control mode will return when the movement of the Right-Hand Joystick is discontinued.



## Hand and Foot Control Pattern: Left Side Controls

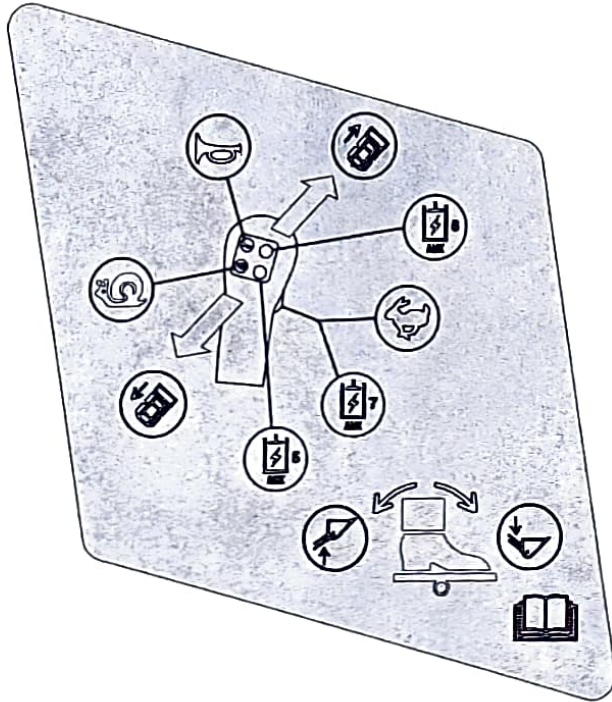

Illustration 241

g06591615

Instruction Film for the Left Side Controls

**Note:** Film on machine will have black background, white characters, and symbols.

### Forward Drive



**Forward** – Push the left-hand joystick forward to move the left side of the machine forward.

Push both joysticks forward equally to move the machine in a straight line.

### Reverse Drive



**Reverse** – Pull the left-hand joystick backward to move the left side of the machine backwards.

Push both joysticks backwards equally to move the machine backwards in a straight line.

### Right Turn

Push the left joystick forward to turn the machine to the right.

Push the left joystick forward and pull the right joystick backward to turn the machine rapidly to the right.

### Horn



**Horn** – Press the switch to sound the horn. Use the horn to alert personnel.

### Two Speed Control



**Two-Speed** – Press the trigger and release the trigger on the front of the left-hand joystick to activate rabbit mode. To activate rabbit mode, the Multifunction Switch must also be in the two-speed position. Refer to "Multifunction Switch for the Left-Hand Trigger (3)" above for instructions about the switch.

**Note:** Keep the work tool close to the ground when you travel in rabbit mode. This method will maximize the stability of the machine.

### Creep Control

The Creep Control allows the operator to select a maximum machine travel speed at full joystick movement. Use creep control for operations that require slow, constant speed independent of engine idle speed.



**Creep Control** – Press the bottom left-hand joystick to turn on the creep control feature. Creep mode will be engaged the next time the joystick passes through NEUTRAL position, either during a change of direction or travel initiation from a stopped position. Press the bottom left-hand button on the left-hand joystick to turn off the creep control. Creep mode will be disengaged the next the joystick passes through the NEUTRAL position, either during a change of direction or stopping the machine.

Refer to "Right Side Controls (Alternate), Creep Control" for detailed information about the creep speed control.

### Lower



**Lower** – Press the front portion (Toe) of the foot pedal to lower the work tool.

### Raise



**Raise** – Press the rear portion (Heel) of the foot pedal to raise the work tool.

# Hand and Foot Control Pattern: Right Side Controls

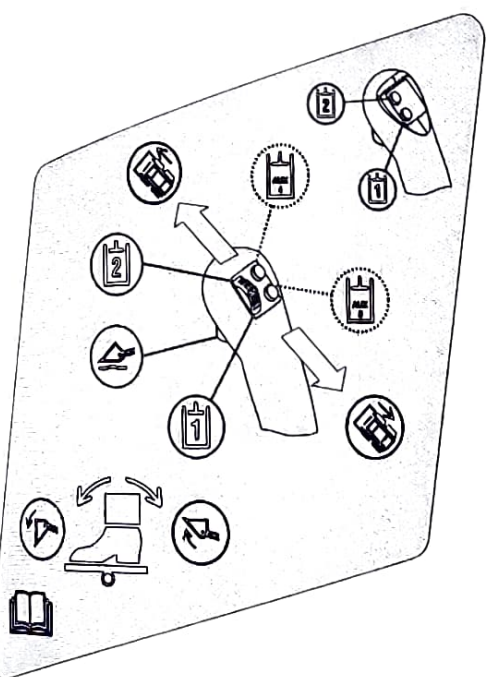



Illustration 242 g06591646

Instruction Film for the Right Side Controls

Note: Film on machine will have black background, white characters, and symbols.

### Forward Drive

 **Forward** – Push the right-hand joystick forward to move the right side of the machine forward.

Push both joysticks forward equally to move the machine forward in a straight line.

### Reverse Drive

 **Reverse** – Pull the right-hand joystick backward to move the right side of the machine backward.

Pull both joysticks backward equally to move the machine backward in a straight line.

### Left Turn

Push the right joystick forward to turn the machine to the left.

Push the right joystick forward and pull the left joystick backward to turn the machine rapidly to the left.

### Dump

 **Dump** – Press the front portion (Toe) of the foot pedal to tilt the work tool downward.

### Tilt Back

 **Tilt Back** – Press the rear portion (Heel) of the foot pedal to tilt the work tool upward.

### Float

 **Float** – Float allows the work tool to follow the contour of the ground.

The following conditions will activate the float function on the machine.

Fully press the front portion (Toe) of the left-hand foot pedal to start the lift arms moving downward and press the right-hand joystick trigger. Float is activated. You may now release the trigger.

Once the float function is engaged, the foot pedal can be returned to the neutral position without affecting the float function. Float will remain engaged until the trigger on the right-hand joystick is pressed again. The float function will disengage also when the bucket is raised or when the bucket is lowered by a command greater than approximately 15% of full foot pedal range.

### Auxiliary Shake Out Mode

Auxiliary Shake Out mode is an aggressive movement of the work tool to dislodge wet or sticky material.

Move the right-hand joystick thumb wheel over the NEUTRAL position three times within a 2 second period to activate Auxiliary Shake Out mode. Auxiliary Shake Out mode will remain engaged while the thumb wheel is moved back and forth over the NEUTRAL position. Normal auxiliary control mode will return when the movement of the thumb wheel is discontinued.

### Bucket Shake Out Mode

Bucket Shake Out mode is an aggressive movement of the work tool to dislodge wet or sticky material.



Move the right side pedal over the NEUTRAL position three times within a 2 second period to activate Bucket Shake Out mode. Bucket Shake Out mode will remain engaged while the right side pedal is moved forward and backward over the NEUTRAL position. Normal bucket control mode will return when the movement of the right side pedal is discontinued.

### Foot Pedal - Adjust

The angle of the foot pedal on machines equipped with Hand and Foot control pattern may be adjusted to improve operator comfort.

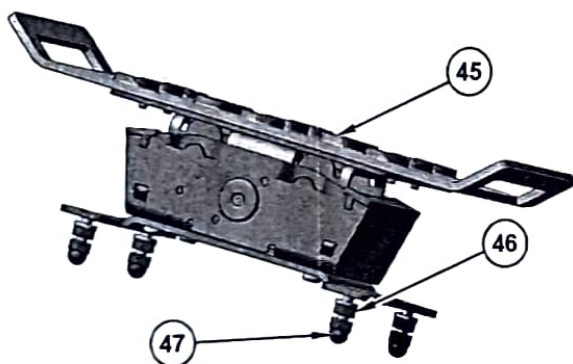

Illustration 243

g06353610

#### Cat Hand and Foot control pattern foot pedal

- (45) Foot Control Pedal
- (46) Hex nut
- (47) Acorn nut

1. Raise the cab.
2. Remove the acorn nuts (47) and Hex nuts (46) from beneath the cab floor.
3. Install up to a maximum of four washers 2mm thick washers.
4. Replace the Hex nuts (46) and torque to  $12 \pm -3 \text{ N}\cdot\text{m}$  ( $9 \pm -2 \text{ lb ft}$ ).
5. Replace the acorn nuts (3) and torque to  $6 \pm -1 \text{ N}\cdot\text{m}$  ( $4 \pm -1 \text{ lb ft}$ ).

### Auxiliary Hydraulic Controls

If the work tool has a wiring harness, connect the work tool harness to the electrical plug on the loader arm. If your High Flow work tool does not have a wiring harness, a Jumper Plug should be installed on the electrical plug for the work tool control. Without this Jumper Plug, the machine will not provide High Flow to the work tool. Refer to your Parts Manual for the current part number for the Jumper Plug.

**Note:** High flow mode requires an electrical connection that is on the loader arm. Refer to Operation and Maintenance Manual, "Work Tool Coupler Operation" or Operation and Maintenance Manual, "Work Tool Operation" for additional details.

**Note:** If the high flow work tool does not have a wiring harness, consult the Operation and Maintenance Manual for the work tool for the proper instructions for attaching the work tool.

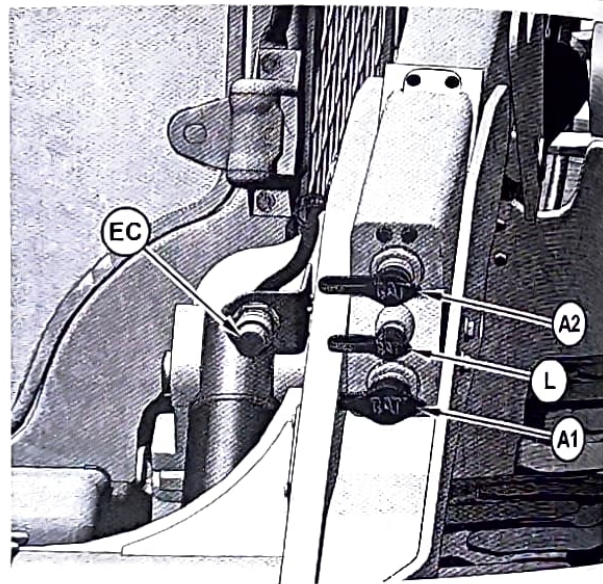

Illustration 244

g06353918

#### Auxiliary Flow Connections - non-XE Models

- (EC) Work Tool Electrical Connector
- (A2) 1/2 inch Hydraulic Supply
- (A1) 1/2 inch Hydraulic Return
- (L) 3/8 inch Case Drain

**Note:** Your machine may not be equipped with all connections shown.



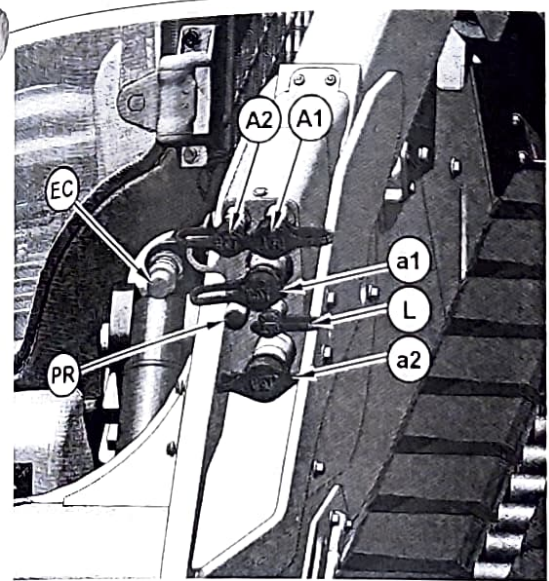

Illustration 245 g06354050

**Auxiliary Flow Connections - XE Models**

- (EC) Work Tool Electrical Connector
- (PR) Pressure Relief Knob
- (a2) 3/4 inch Hydraulic Return
- (A2) 1/2 inch Hydraulic Supply
- (a1) 3/4 inch Hydraulic Supply
- (A1) 1/2 inch Hydraulic Return
- (L) 3/8 inch Case Drain

**Note:** Your machine may not be equipped with all connections shown.

**Note:** If Screw-to-Connect style couplings are used, it is recommended to swap the position of the male & female couplings to improve hand clearance. Port (a1) will be the female and port (a2) will be the male in this special case. The work tool's connections will need to be swapped as well to ensure high flow in the forward direction with the thumbwheel rotated in the UP or FORWARD direction.

**1** **Auxiliary Hydraulic Control (A1) –** This control provides hydraulic oil flow to the auxiliary connections on the loader arm. Engage the control to provide hydraulic oil flow to the female connector (s) (A1) and (a1).

**2** **Auxiliary Hydraulic Control (A2) –** This control provides hydraulic oil flow to the auxiliary connections on the loader arm. Engage the control to provide hydraulic oil flow to the male connector (s) (A2) and (a2).

**Case drain line (L) –** Some hydraulic or hydromechanical work tools will have a Case drain line coming off the work tool motor. It is a tube that routes back to the cooler to the low side return and back to the hydraulic tank.

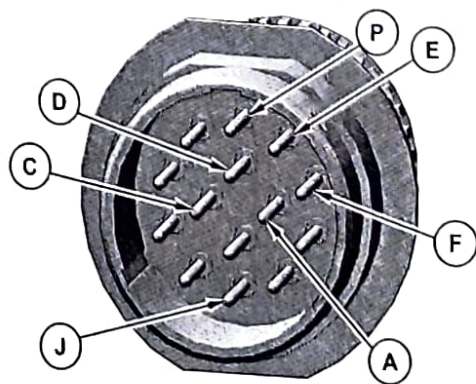

Illustration 246 g06353203

**Work Tool Electrical Connection (EC)**

- (A) Left-Hand Trigger Control "AUX 7"
- (C) C- Control "Aux 3"
- (D) C+ Control "Aux 4"
- (E) C2 Control "Aux 5"
- (F) C1 Control "Aux 6"
- (J) Auxiliary Electrical Control "AUX 8"
- (P) +12V with Key ON



**Auxiliary Electrical Control 3 (C-) –** This control provides electrical power to activate additional work tool functions using a three-position diverter valve that is on some work tools. Press the switch and hold the switch to send power to the pin (C) this action will activate the required Work Tool function. Release the switch to deactivate the control. If auxiliary hydraulic controls(A1/A2), and continuous flow is inactive, and a work tool featuring auto reverse functionality (such as cold planers) is connected, pressing the switch will send power to pin (C) and provide hydraulic flow to the female connector (s) (A1) and (a1).



**Auxiliary Electrical Control 4 (C+) –** This control provides electrical power to activate additional work tool functions using a three-position diverter valve that is on some work tools. Press the switch and hold the switch to send power to the pin (D). This action will activate the required Work Tool function. Release the switch to deactivate the control. If auxiliary hydraulic controls(A1/A2), and continuous flow is inactive and a work tool featuring auto reverse functionality (such as cold planers) is connected, pressing the switch will send power to pin (D) and provide hydraulic flow to the female connector (s) (A1) and (a1).





**Auxiliary Electrical Control 5 (C2)** – This control provides electrical power to activate additional work tool functions

using a three-position diverter valve that is on some work tools. Press the switch and hold the switch to send power to the pin (E) this will activate the required Work Tool function. Release the switch to deactivate the control.



**Auxiliary Electrical Control (C1)** – This control provides electrical power to activate additional work tool functions

using a three-position diverter valve that is on some work tools. Press the switch and hold the switch to send power to pin (F). This action will activate the required Work Tool function. Release the switch to deactivate the control.



**Left-Hand Trigger** – Pull the trigger and hold the trigger on the left-hand joystick to provide electrical power to pin (A).

Release the trigger to deactivate the control.

Multifunction Switch must be in the Aux 7 position. Refer to "Multifunction Switch for the Left-Hand Trigger (3)" above for instructions about the switch.

**Note:** These controls are used with the individual Work Tool Operation and Maintenance Manual to understand fully the functions of each control.



**Pressure Relief Knob (PR)** – See Operation and Maintenance Manual, Work Tool Coupler Operation Hydraulic System Pressure Relief for information.

108246717

## Battery Disconnect Switch

**SMCS Code:** 1411; 1411-B11

If equipped, the battery disconnect switch is located in the engine compartment near the battery. Machines that require DEF will include a DEF Purge Indicator Lamp when the battery disconnect switch is installed.

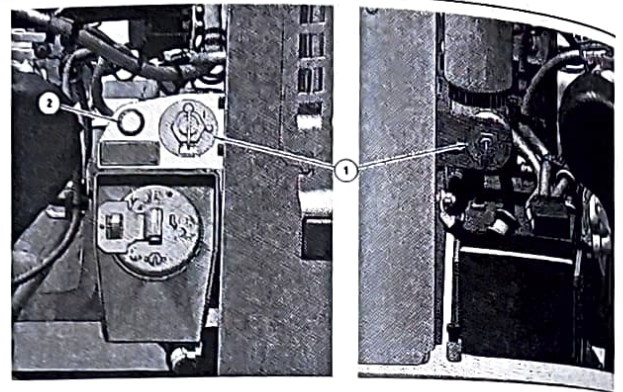

Illustration 247

g06354900

- (1) Battery Disconnect Switch  
(2) Diesel Exhaust Fluid (DEF) Purge Indicator Lamp

### NOTICE

Do not conduct any service procedures on the DEF system until the DEF purge indicator lamp is not illuminated. The indicator lamp may remain illuminated for up to 12 minutes when the key switch is OFF. When the indicator is on, the DEF system is still powered.



**ON** – To activate the electrical system, insert the disconnect switch key and turn the battery disconnect switch (1) clockwise. The battery disconnect switch must be turned to the ON position before you start the engine.



**OFF** – To deactivate the electrical system, turn the battery disconnect switch (1) counterclockwise to the OFF position once the DEF Purge Indicator Lamp (2) is off.

The battery disconnect switch and the Key Switch perform different functions. The entire electrical system is disabled when you turn the Battery Disconnect Switch to OFF. The battery remains connected to the electrical system when you turn the Key Switch to OFF.

If equipped, the DEF Purge Indicator Lamp (2) will remain ON after the Key Switch is turned OFF. This procedure is to ensure the DEF injector cool down and DEF system purge processes are complete. Disconnecting the battery while the DEF Purge Indicator Lamp (2) is ON can result in failure of the DEF injector, DEF Pump, or DEF lines.

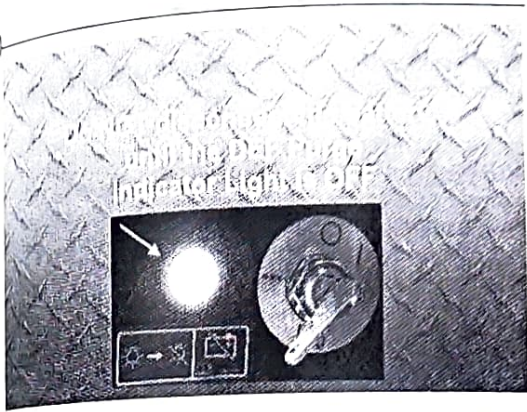

Illustration 248 g06598111

A warning will be displayed on the Display screen inside the cab at key OFF.

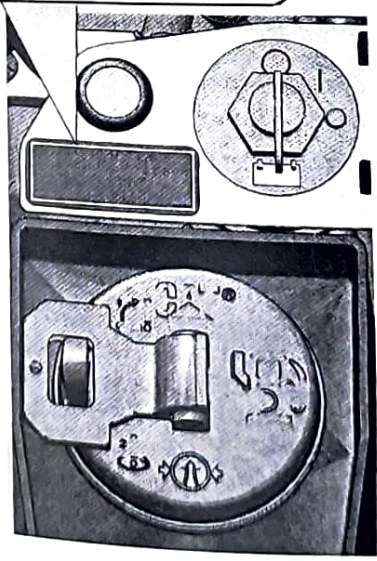
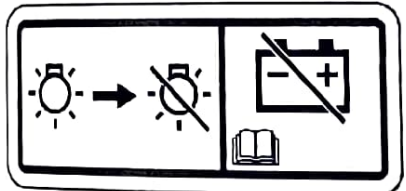

Illustration 249 g06354982

Turn the battery disconnect switch to the OFF position and remove the key when you service the electrical system or any other machine components.

- short circuits
- current draw via some components
- vandalism

**NOTICE**  
Never move the battery disconnect switch to the OFF position while the engine is operating. Serious damage to the electrical system could result.

To ensure that no damage to the engine occurs, verify that the engine is fully operational before cranking the engine. Do not crank an engine that is not fully operational.

Perform the following procedure to check the battery disconnect switch for proper operation:

1. With the battery disconnect switch in the ON position, verify that electrical components in the operator compartment are functioning. Verify that the hour meter is displaying information. Verify that the engine will crank.
2. Turn the battery disconnect switch to the OFF position.
3. Verify that the following items are not functioning: electrical components in the operator compartment, hour meter, and engine cranking. If any of the items continue to function with the battery disconnect switch in the OFF position, consult your Cat dealer.

**Note:** The Fire Suppression System has an internal battery. In the event of a power loss or if the battery disconnect switch is in OFF position, the fire suppression system is equipped with an Internal Reserve power source that may last up to 72 hours.

08230782

## Diesel Particulate Filter Regeneration

SMCS Code: 108F

- S/N: B621-Up
- S/N: GJ21-Up
- S/N: HX21-Up
- S/N: L321-Up
- S/N: ZB21-Up
- S/N: JX31-Up
- S/N: LB31-Up
- S/N: R231-Up
- S/N: EK51-Up
- S/N: GJ51-Up
- S/N: WS51-Up



S/N: GK61-Up  
 S/N: KC61-Up  
 S/N: ME61-Up  
 S/N: PF61-Up  
 S/N: S381-Up  
 S/N: AN91-Up  
 S/N: BT91-Up  
 S/N: BX91-Up  
 S/N: CW91-Up  
 S/N: CY91-Up  
 S/N: DY91-Up  
 S/N: GX91-Up  
 S/N: JX91-Up  
 S/N: RB91-Up  
 S/N: TE91-Up  
 S/N: S7E1-Up  
 S/N: W6E1-Up  
 S/N: Z9E1-Up  
 S/N: KXL1-Up  
 S/N: S1L1-Up  
 S/N: P3R1-Up  
 S/N: K5S1-Up  
 S/N: XES1-Up  
 S/N: HSX1-Up  
 S/N: KEZ1-Up

## General Information

Regeneration is the removal of soot from the Diesel Particulate Filter (DPF). Active and passive regeneration is used to regenerate the DPF. The DPF traps both soot and ash. The soot is removed during regeneration. The ash is removed through a cleaning process. Refer to the Operation and Maintenance Manual, "Diesel Particulate Filter - Clean/Replace" for more information on the service of the DPF.

## Modes of Regeneration

**Passive** – Passive Regeneration occurs when the exhaust temperature is high enough for regeneration to occur. Passive regeneration may occur unnoticed by the operator. No operator action is required. Operating the machine above mid throttle and under load allows for passive regeneration during normal operation. Low idle and low load applications will

have lower exhaust temperatures, where passive regeneration is not possible.

**Active** – Active regeneration is a late injection of fuel into the combustion chamber, which sufficiently raises the exhaust temperature for active regeneration. The engine ECM uses multiple inputs from the engine to determine when active regeneration is needed. All applications, even high load, will require active regenerations. However, active regeneration will not occur as frequently as low idle and low load applications.

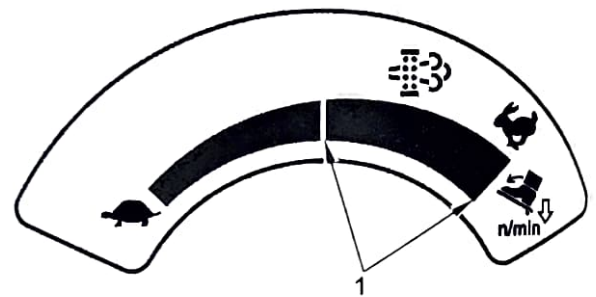

Illustration 250

g03395636

(1) Active regeneration threshold

**Note:** The green area is the active regeneration threshold.

There will be a slight change in the exhaust noise during active regeneration. Active regenerations may require the engine rpm to be above the active regeneration threshold. The active regeneration may take up to 30 minutes to complete.



When active regeneration is required with the parking brake and hydraulic lockout engaged, automatic adjustments of the engine speed by the ECM may occur to keep the engine RPM above the active regeneration threshold.

When active regeneration is required and the machine is being operated below the active regeneration threshold, the DPF alert indicator may illuminate. The operator can increase the rpm above the active regeneration threshold with the Engine Speed Control Knob. Active regeneration will occur and the DPF light will turn off.

If increasing the RPM is not acceptable, alternatively the operator can allow a parked regeneration. For a parked regeneration to occur, the engine must be at low idle, the parking brake engaged, and the hydraulic lockout engaged. If those conditions are met for approximately 2 minutes, the ECM will slowly increase the engine rpm and active regeneration will begin. After completing the active regeneration the engine speed will slowly decrease down to low idle.

The following chart describes the alert indicators and what actions, if any, the operator needs to perform to allow active regeneration.

### Warning Symbols

-  1 - DPF
-  2 - Alert
-  3 - Cab Alarm

### Engine Emission Alert

Table 18

Warning (1)	Machine Action	Operator Action
None	If the parking brake and hydraulic lockout are engaged, the ECM may increase the engine speed	No action required.
1 - Solid Amber	If the parking brake is not engaged and the engine speed is below the green shaded area on the Engine Speed Control Knob, the DPF light will turn on.	Increase the engine rpm to the green shaded area on the Engine Speed Control Knob, and the DPF light will turn off. or Bring the machine to a stop. Engage the parking brake and hydraulic lockout. Set the engine speed to low idle. The ECM will automatically increase the engine rpm to the regeneration threshold. The regeneration may take up to 30 minutes.
1 - Solid Amber 2 - Solid Amber	The engine will derate until active regeneration is completed	Bring the machine to a stop. Engage the parking brake and hydraulic lockout. Set the engine speed to low idle The ECM will automatically increase the engine rpm to the regeneration threshold. The regeneration may take up to 30 minutes.
1 - Solid Amber 2 - Flashing Amber 3 - Beeping	Engine will remain derated.	A regeneration can only be done through Cat Electronic Technician (ET), by an authorized Cat dealer. Consult your local Cat dealer. If the engine is run through these warning indicators, the DPF will require servicing and may require replacement. Engine damage can occur. Shut down the machine safely and contact your local Cat dealer.

(1) For Models equipped with either C3.3B or C3.8 Engine Only



Table 19

Warning (1)	Machine Action	Operator Action
None	If the parking brake and hydraulic lockout are engaged, the ECM may increase the engine speed	No action required.
1 - Solid Amber	If the parking brake is not engaged and the engine speed is below the green shaded area on the Engine Speed Control Knob, the DPF light will turn on.	Increase the engine rpm to the green shaded area on the Engine Speed Control Knob, and the DPF light will turn off. or Bring the machine to a stop. Engage the parking brake and hydraulic lockout. Set the engine speed to low idle. The ECM will automatically increase the engine rpm to the regeneration threshold. The regeneration may take up to 30 minutes.
1 - Flashing Amber 2 - Solid Amber	If equipped, the Advanced Display will display a pop-up warning once the DPF light has been on for 1 hour.	
1 - Flashing Amber 2 - Flashing Amber	The engine will derate until active regeneration is completed	Bring the machine to a stop. Engage the parking brake and hydraulic lockout. Set the engine speed to low idle The ECM will automatically increase the engine rpm to the regeneration threshold. The regeneration may take up to 30 minutes.
1 - Flashing Amber 2 - Flashing Amber 3 - Beeping	Engine will remain derated.	A regeneration can only be done through Cat Electronic Technician (ET), by an authorized Cat dealer. Consult your local Cat dealer. If the engine is run through these warning indicators, the DPF will require servicing and may require replacement. Engine damage can occur. Shut down the machine safely and contact your local Cat dealer.

(1) For Models equipped with a C2.2 Engine Only

**Note:** If the machine is equipped with the Advanced Display, additional diagnostic information will be displayed in the monitor.

## Carbon Dioxide (CO<sub>2</sub>) Emissions Statement

Emissions regulations require that the value of the CO<sub>2</sub> emissions be reported to the end user. These CO<sub>2</sub> values are measured per the EU type approval process. These values are recorded in EU type approval certificates. CO<sub>2</sub> measurement results from testing over a fixed test cycle, under laboratory conditions, with a parent engine representative of the engine family. This value shall not imply or express any guarantee of the performance of a particular engine.

Table 20

Serial Number Prefixes	Engine	CO <sub>2</sub> Emission Level
226D3 (EK5), 232D3 (GJ5), 239D3 (K5S), 249D3 (WS5)	C2.2	799 g/kWh
236D3 (GK6), 242D3 (ME6), 257D3 (S7E), 259D3 (TE9)	C3.3B	807 g/kWh

(continued)

(Table 20, contd)

246D3 (PF6), 262D3 (W6E), 279D3 (Z9E), 289D3 (BT9)	C3.3B	807 g/kWh
272D3 (L32), 272D3 XE (S1L), 299D3 (P3R, JX3), 299D3 XE (B62, GX9, R23, S38)	C3.8	758 g/kWh

## EU Stage V Emissions Control System (European Union)

### Operation & Maintenance of the Stage V Emissions Control System

The engine, including the emissions control system, shall be operated, used, and maintained in accordance with the instructions provided to the end users to maintain the emissions performance of the engine within the requirements applicable to the engine category.

No deliberate tampering with or misuse of the engine emissions control system should take place. In particular regarding deactivating or not maintaining an exhaust gas recirculation (EGR) or a reagent dosing system if equipped.

It is essential to take prompt action to rectify any incorrect operation, use, or maintenance of the emissions control system in accordance with the rectification measures indicated by the unique warning diagnostic codes outlined below.

### Failure Warnings and Operator Inducement Strategy

The EU Stage V Emissions Control system detects failures of the system by PM control diagnosis (PCD) and NOx control diagnosis (NCD). The system logs warning codes in the engine electronic control module (ECM) and signals the operator of system failure detection via a combination of visual and audible warnings in the machine operator station. Ignoring the operator warning signals will lead to the activation of the operator inducement system, which may result in an effective disablement of the machine.

Table 21

EU Stage V Emissions Control System Failure Warnings for C3.3B & C3.8 Engines						
Emission Failure Cause	Control Diagnostics System	Warning Code (SPN-FMI)	Event Level	Visual Warnings via Display	Audible Warning via Cab Alarm	Inducement Response
Removal of the DPF system	PCD (Particulate Matter)	3936-7	3	DPF Alert Indicator <sup>(1)</sup> Driver Alert Indicator <sup>(1)</sup> Diagnostic Pop-Up	Yes	None
Loss of function of the DPF system		3936-2	2		No	
Failure of the PCD system		3251-3	2		No	
Removal of the EGR system	NCD (NOx Emission)	523578-2	2		No	2 Stage Engine Derate
Removal of the MAF sensor		132-4	3		Yes	

<sup>(1)</sup> Refer to Operation and Maintenance Manual, Alert Indicators for additional information.

Table 22

EU Stage V Emissions Control System Failure Warnings for C2.2 Engines						
Emission Failure Cause	Control Diagnostic System	Warning Code (SPN-FMI)	Event Level	Visual Warnings via Display	Audible Warning via Cab Alarm	Inducement Response
Loss of Function of the DPF	PCD (Particulate Matter)	5246-16	2	Driver Alert Indicator (flashing) & Diagnostic Pop Up (when equipped with Advanced Display)	None	Yes
		5246-0	3		Yes	Yes
Removal of DPF		3251-1	3		Yes	No
Loss of Function of the EGR System		NCD (NOx Emission)	3251-18		2	None
	27-3		2		None	yes
	27-4		2		None	yes



**Alert Indicators**

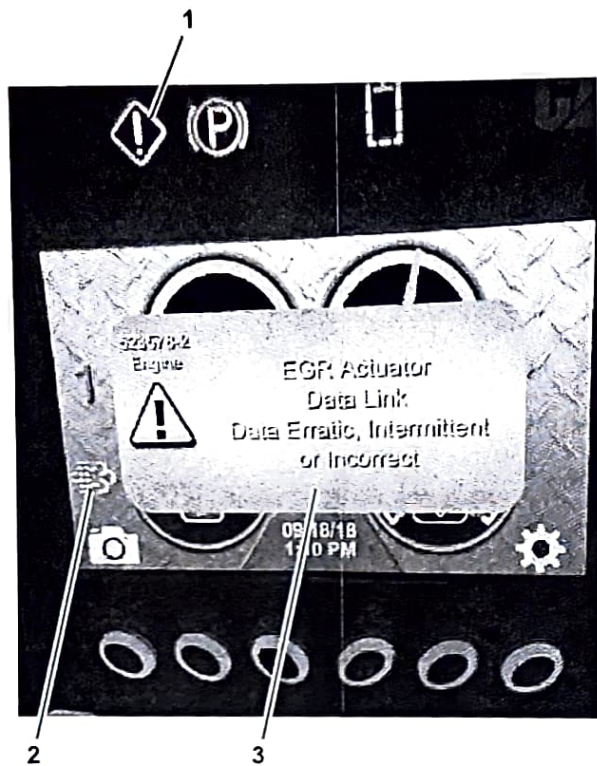

Illustration 251

g06362469

**Alert Indicators & Pop-Up Warnings Identification**

- (1) Driver Alert Indicator
- (2) DPF Alert Indicator
- (3) Diagnostic Pop-Up

**Inducement Levels**

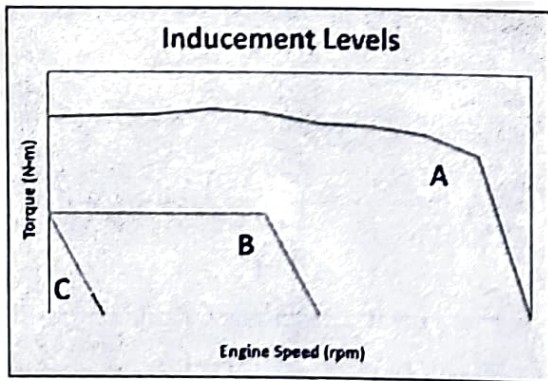

Illustration 252

g06362472

**EU Stage V Emissions Control System Inducement Levels**

A – No Fault Code, Normal Operation Range

B – Stage 1 Inducement:

- Response: Engine De-rated to within 50% Max Torque, 60% Rated Speed
- Occurrence: After 3 hours 15 minutes of active fault

**C – Stage 2 Inducement:**

- Response: Engine delivers nearly No Net Torque, Engine Speed near Low Idle
- Occurrence: After 4 hours of active fault

**DPF Service Operator Notification (C3.3B & C3.8 Engines Only)**

The Diesel Particulate Filter (DPF) traps particulate matter in the form of both soot and ash. Soot is burned off periodically during the regeneration process, but ash will continue to accumulate slowly over time. Eventually, the DPF will become fully loaded with ash and will need to be serviced (cleaned or replaced) by an authorized Cat dealer.

The EU Stage V emissions control system estimates the DPF's ash loading to provide maximum DPF life. When the ash load reaches an estimated 100%, the machine control system will generate an active event code and display a message to the operator. At this point it is recommended that the DPF be serviced. The message can be dismissed from the display and will reappear every 8 hours or each key cycle. After 50 hours without a service tool reset, the active event code will escalate and display a similar message every 15 minutes or each key cycle. If the message is continually ignored, the high ash content within the DPF will cause a high frequency of DPF regeneration triggering a diagnostic that is accompanied with an engine derate.

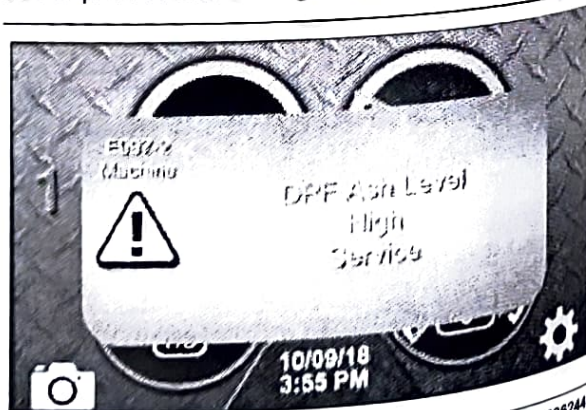

Illustration 253

g06362442

**Typical Pop-Up Message of the DPF Service Notification**

**DPF Service Operator Notification (C2.2 Engines Only)**

The Diesel Particulate Filter (DPF) traps particulate matter in the form of both soot and ash. Soot is burned off periodically during the regeneration process, but ash will continue to accumulate very slowly over time. The DPF is considered "fit for life" on these models and should never require servicing during the useful life of the machine. If you suspect a problem with the DPF however, stop the machine safely and contact your local Cat dealer.

**Engine Manufacturer Contact Information (C3.3B & C3.8 Engines Only)**

Kubota Europe SAS  
19-25, Rue Jules Verdecruysse, Z.I. BP88  
95101 Argenteuil Cedex  
France

Kubota Europe S.A.S. Italy Branch  
Via Grandi, 29  
20068 Peschiera Borrome (MI)  
Italy

Kubota (Deutschland) GmbH  
Senefelder Str. 3-5  
63110 Rodgau / Nieder-Roden  
Germany

**Engine Manufacturer Contact Information (C2.2 Engines Only)**

Manufacturer:

Caterpillar Inc.  
100 N.E. Adams Street  
Peoria, Illinois 61629  
USA

Entity authorized by the manufacturer at the territory of Eurasian Economic Union:

Caterpillar Eurasia LLC  
75, Sadovnicheskaya Emb.  
Moscow 115035  
Russia

106135026

**Selective Catalytic Reduction Warning System**

SMCS Code: 1091-WXX; 7400

- S/N: B621-Up
- S/N: GJ21-Up
- S/N: HX21-Up
- S/N: L321-Up

- S/N: JX31-Up
- S/N: LB31-Up
- S/N: R231-Up
- S/N: S381-Up
- S/N: AN91-Up
- S/N: BX91-Up
- S/N: CY91-Up
- S/N: DY91-Up
- S/N: GX91-Up
- S/N: S1L1-Up
- S/N: P3R1-Up
- S/N: XES1-Up

The selective catalytic reduction (SCR) system is a system used to reduce NOx emissions from the engine. Diesel exhaust fluid (DEF) is pumped from the DEF tank and is sprayed into the exhaust stream. The DEF reacts with the SCR catalyst to reduce NOx and leaves a nitrogen and water vapor.

**NOTICE**

Allow the engine to perform a DEF purge of the DEF system before you turn the battery disconnect switch to OFF. Disconnecting the battery power too soon may prevent proper cool down of DEF injector and purging of the DEF system after the engine is shut down. Refer to Operation and Maintenance Manual, "Battery Disconnect Switch" for more information.



Illustration 254

g03821224

The DEF level gauge icon is designated the "SCR Warning" alert indicator. Refer to "Right Side Controls (Alternate), Monitoring Screen, Fuel & Diesel Exhaust Fluid (DEF) Level Gauge" for location.





Illustration 255

g03821224

- At Level 1 the SCR Warning alert indicator will change from white to solid RED.



Illustration 256

g03821235

- At Level 2 the SCR Warning alert indicator will flash RED, a pop-up warning will appear in the display with the diagnostic code description, and the Driver alert indicator will flash AMBER. Maximum engine speed is reduced to 60% of rated speed and maximum torque is reduced by 50%.



Illustration 257

g03821243

- At Level 3 the SCR Warning alert indicator will flash RED, a pop-up warning will appear in the display with the diagnostic code description. The Driver alert indicator will flash AMBER, and the audible alarm will occur. Engine speed is limited to nearly low idle and no engine torque is available.

The SCR Warning alert indicator will turn ON when the DEF tank level is low, a quality issue with the DEF is detected, or there is a fault in the SCR system. The following are the parameters for each warning type.

**Diesel Exhaust Fluid Level** – When the DEF gauge is near the red range, the indicator will go to a Warning Level 1. After 45 minutes of operation, the warning will increase to Level 2. When the DEF tank level is empty, the warning will increase to a Level 3.

**Diesel Exhaust Fluid Quality** – The sensor in the DEF tank measures the quality of the DEF. If non-standard DEF is supplied or is diluted, the lamp will go to Warning Level 1. After operating for 3 hours and 15 minutes, the warning will increase to Level 2. After operating for another 45 minutes, the warning will increase to a Level 3.

**SCR System Fault** – If any of the SCR system sensors are disconnected or any fault codes occur in the SCR system, the indicator will go to a Warning Level 1. After 3 hours and 15 minutes, the warning will go to a Level 2. After operating for another 45 minutes, the warning will increase to a Level 3.

i08224154

## Alert Indicators

SMCS Code: 7450; 7451

The alert indicators are on the right-hand display.

**Note:** Your machine may not be equipped with all the indicators that are discussed in this topic.

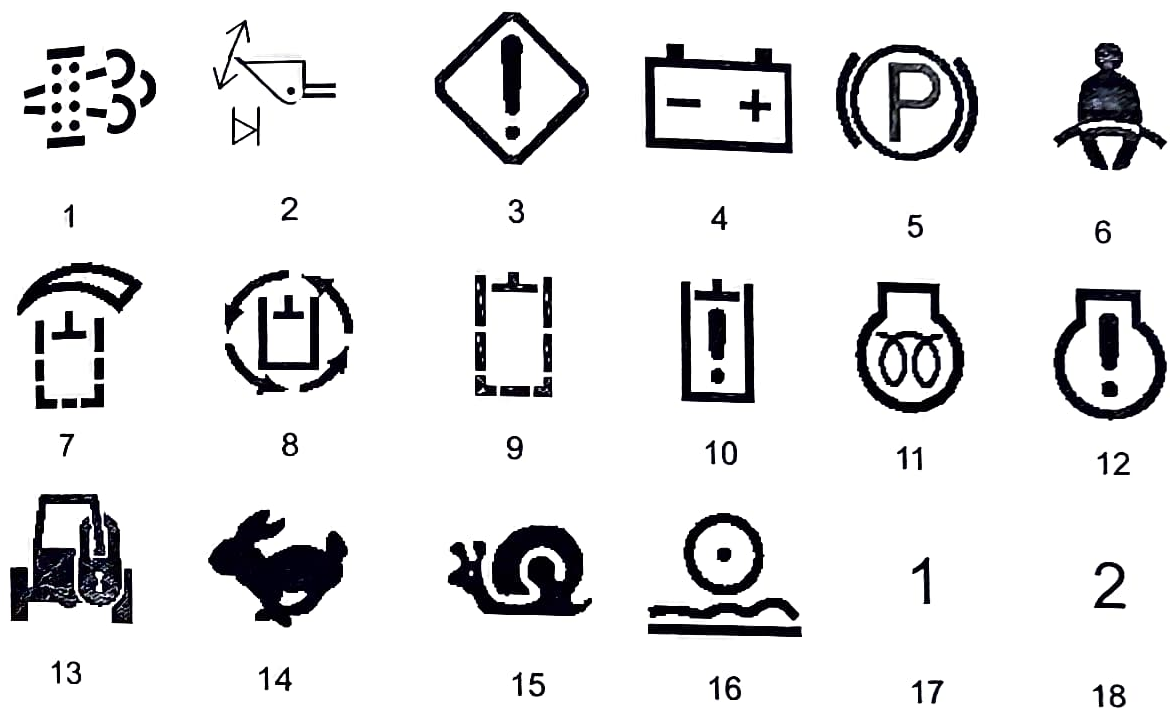

Illustration 258  
Left Side

g02817376

- 1 - Diesel Particulate Filter
- 2 - Self-Level System
- 3 - Driver Alert
- 4 - System Voltage
- 5 - Parking Brake
- 6 - Operator Presence
- 7 - Auxiliary Hydraulic High Flow
- 8 - Continuous Flow
- 9 - Work Tool System
- RED Work Tool Lockout
- AMBER Interlock Override
- 10 - Hydraulics
- RED Hydraulic Temperature
- AMBER Hydraulic Filter Bypass
- 11 - Cold Starting Aid
- 12 - Engine Condition Indicator

- RED Coolant Temperature
- RED Oil Pressure
- AMBER Air Cleaner Indicator
- 13 - Anti-Theft Security System
- 14 - Two-Speed Indicator
- 15 - Creep Control Mode Indicator
- 16 - Ride Control
- 17 - Cat Control Pattern
- 18 - H-Control Pattern

**1 - Diesel Particulate Filter** This alert will activate when the diesel particulate filter needs regeneration. Refer to this Operation and Maintenance Manual, "Diesel Particulate Filter Regeneration" for details.

**Note:** Machines equipped with EU Stage V Emission Controls will also use this alert indicator to signal system failure. Refer to this Operation and Maintenance Manual, "Diesel Particulate Filter Regeneration", "EU Stage V Emissions Control System" for applicable models and details.



**2 - Self-Level System** This alert indicator will light when the Self-Level System is ON. This alert indicator will blink twice when the user-selected work tool target angle is established. Refer to Operation and Maintenance Manual, Operator Controls Left-Side Controls, Self-Level System Switch.

**3 - Driver Alert** This alert indicator will activate when there is a problem which requires operator attention.

**Note:** Machines equipped with EU Stage V Emission Controls will also use this alert indicator to signal system failure. Refer to this Operation and Maintenance Manual, "Diesel Particulate Filter Regeneration", "EU Stage V Emissions Control System" for applicable models and details.

**Note:** Other alert indicators that light or the gauges may help investigate the cause of any problems.

There are three levels of severity for the indicator:

**Level 1** – If the alert indicator is on continuously, stop the machine at the earliest convenience. Check the following before consulting your Cat dealer.

- Ensure that the machine has been adequately warmed up. Refer to Engine Starting for an explanation of the engine and ambient conditions that may trigger this.
- If the Engine Condition alert indicator is AMBER, water may be present in the fuel. Drain the water from the fuel/water separator. For more information refer to "Operation Maintenance Manual" Fuel System Primary Filter (Water Separator) - Drain.
- If the Engine Condition alert indicator is AMBER, the engine air filter may be restricted. For more information refer to "Operation Maintenance Manual" Engine Air Filter Primary Element - Clean/Replace.
- If the Hydraulics alert indicator is AMBER, the filter is bypassing. Check that the hydraulic oil filter is not plugged. For more information refer to "Operation Maintenance Manual" Hydraulic System Oil Filter - Replace. See also Oil Filter - Inspect.
- Check for proper battery voltage and ensure that the alternator and wiring are good.

**Level 2** – If the alert indicator is flashing and there is no audible alarm, severe component damage could occur. Stop the machine at the earliest convenience and check the following before consulting your Cat dealer.

- If the Engine Condition alert indicator is RED and the maximum engine speed is reduced, water may be present in the fuel. Drain the water from the fuel/water separator. For more information refer to "Operation Maintenance Manual" Fuel System Primary Filter (Water Separator) – Drain
- If the Engine Condition alert indicator is RED and the maximum engine speed is reduced, the engine air filter may be restricted. For more information refer to "Operation Maintenance Manual" Engine Air Filter Primary Element - Clean/Replace.
- Check for proper battery voltage and ensure that the alternator and wiring are good.
- If the machine is equipped with a Diesel Particulate Filter, move the machine to a safe location and set the parking brake. If the engine RPM begins to rise shortly, allow the machine to complete a regeneration cycle. For more information refer to "Operation Maintenance Manual" Diesel Particulate Filter Regeneration.
- If the SCR Warning alert indicator is flashing RED, check the Diesel Exhaust Fluid Level. See Diesel Exhaust Fluid - Fill. Refer to Selective Catalytic Reduction Warning System for an explanation of the various SCR warning levels.
- A sensor on the machine may be faulted or has come unplugged. For tracked machines, check that the wiring to the drive motor speed sensor wiring is not damaged. Consult your Cat dealer for advanced troubleshooting support.

**Level 3** – If the alert indicator is flashing and there is an audible alarm, injury to the operator or severe component damage could occur. Stop the machine immediately and check the following before consulting your Cat dealer:

- Check the engine oil. See Operation Maintenance manual, Engine Oil level - Check. If the Engine Condition alert indicator is RED, the engine oil filter may be plugged. See Engine Oil and Filter - Change. See also Oil Filter - Inspect.
- If the Engine Condition alert indicator is RED, the engine coolant temperature may be high. Clean the engine radiator, reduce the engine load, and allow the engine to cool. For more information refer to Operation Maintenance Manual, Radiator Core - Clean.
- If the Hydraulics alert indicator is RED, the hydraulic oil temperature is high. Check the hydraulic oil level. Refer to Operation Maintenance Manual, Hydraulic System Oil Level - Check. Clean the hydraulic oil cooler, reduce the hydraulic load, and allow the system to cool. See Radiator Core - Clean.



If the SCR Warning alert indicator is flashing RED, check the Diesel Exhaust Fluid Level. See Diesel Exhaust Fluid - Fill. Refer to Selective Catalytic Reduction Warning System for an explanation of the various SCR warning levels.

- A sensor on the machine may be faulted or has come unplugged. For tracked machines, check that the wiring to the drive motor speed sensors is not damaged. Consult your Cat dealer for advanced troubleshooting support.

**4 - System Voltage** This alert indicator will light if there is a malfunction in the electrical system. If this alert indicator comes on, the system voltage is too high for normal machine operation or too low for normal machine operation.

If electrical loads are high and the engine speed is near low idle, increase the engine speed to high idle to get more output from the alternator. If the alert indicator for the electrical system turns off within 1 minute, the electrical system is probably operating in a normal manner. However, the electrical system may be overloaded during periods of low engine speeds.

Increase the engine idle speed with the governor lever to compensate for a higher electrical load on the system.

If this procedure does not cause the alert indicator to turn off, move to a convenient location. Investigate the cause (loose alternator belt, broken alternator belt, or faulty batteries).

**5 - Parking Brake** This alert indicator will light when the parking brake is engaged. The alert indicator should come on during start-up. The alert indicator should go out when the parking brake is disengaged.

**6 - Operator Presence** This alert indicator will light when the armrests are in the RAISED position. The alert indicator will light when the operator gets out of the operator seat. The alert indicator should go out when the operator is in the operator seat and the armrests are in the LOWERED position.

**7 - Auxillary Hydraulic High Flow** This alert indicator will light when the high flow hydraulic system is activated.

**8 - Continuous Flow** This alert indicator will flash when the machine is in "Continuous Flow Ready" mode. This alert indicator will light when continuous flow is activated.

**9 - Work Tool System**

- This alert indicator will light red when the work tool lockout control is activated.
- This alert indicator will light amber when the interlock override is activated.

**10 - Hydraulics**

- This alert indicator will light red and an audible alert will sound when the temperature of the hydraulic oil is too high. If this indicator comes on, stop the machine immediately. Stop the engine and investigate the problem.
- This indicator will light amber when the hydraulic oil filter is not functioning properly. Stop the machine and replace the oil filter. The indicator will stay on until the hydraulic oil has warmed up. Do not operate the machine until the light turns off.

**11 - Cold Starting Aid** With the engine start switch in the ON position, this alert indicator will light when the aid is activated. Refer to Operation and Maintenance Manual, "Engine Starting" for more information about the heater.

**12 - Engine Condition Indicator** This alert will activate when there is a problem which requires operator attention.

**Note:** Other alert indicators that light or the gauges may help investigate the cause of any problems.

**Note:** This alert indicator is only on machines equipped with the Basic Display. The Advanced Display communicates relevant engine diagnostic information with descriptive pop-up screens.

There are three levels of severity for this indicator:

- Level 1: If the alert indicator is on continuously, stop the machine at the earliest convenience. This alert is for the air cleaner indicator. Stop the machine and service the air cleaner.
- Level 2: If the alert indicator is flashing and there is no audible alarm, severe component damage could occur. Change your operation or perform the indicated maintenance.
- Level 3: If the alert indicator is flashing and there is an audible alarm, injury to the operator or severe component damage could occur. Stop the machine immediately and stop the engine.

**13 - Anti-Theft Security System** This alert indicator will light when the Anti-Theft Security System is activated. Refer to Operation and Maintenance Manual, "Anti-Theft Security System" for more details about the security system.

**14 - Two-Speed Indicator** This alert indicator will light when two-speed travel mode is engaged.

**15 - Creep Control Mode Indicator** This alert indicator will light when Creep Control mode is engaged.

**16 - Ride Control** This alert indicator will light when the Ride Control switch is "ON" and the necessary ground speed is reached for Ride Control activation.



**17 - Cat Control Pattern** If your machine is equipped with the optional Selectable Control Pattern Switch, this alert indicator will flash until a control pattern is selected via the switch. This alert indicator will light when the Cat Control Pattern is activated.

**Note:** Refer to Operation and Maintenance Manual, "Operator Controls - Joystick Controls" for information about the joystick control patterns.

**18 - H-Control Pattern** If your machine is equipped with the optional Selectable Control Pattern Switch, this alert indicator will flash until a control pattern is selected via the switch. This alert indicator will light when the H-Control Pattern is activated. This alert indicator will also be lit when the machine is equipped with the Dedicated H-Control Pattern option.

**Note:** Refer to Operation and Maintenance Manual, "Operator Controls - Joystick Controls" for information about the joystick control patterns.

107942720

## Fire Suppression System (If Equipped)

**SMCS Code:** 1000; 7000; 7401; 7605; 7615

The machine is monitored with a detection and actuation system which is typically connected to a fire suppression system for 24-hour fire suppression protection. The operator of the machine should be provided with hands-on training by an authorized OEM Manufacturer.

## Front Panel Indicators

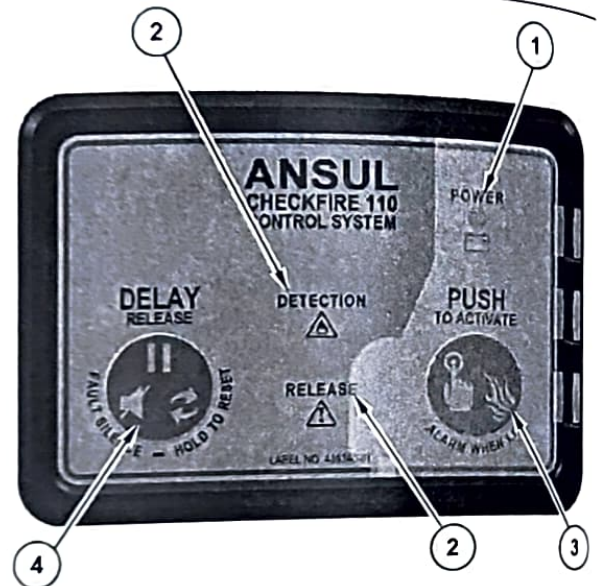

Illustration 259

g06410996

### Fire Suppression System Controller

- (1) Power LED
- (2) Release and Detection LEDs
- (3) Push to Activate Button/LED
- (4) Delay/Reset/Silence Button

Machines built with the optional factory installed fire suppression systems, are equipped with manual actuators. The quantity of actuators may vary, according to the machine. The manual actuators can be triggered by pulling the safety pin and depressing the red button. Prior to actuating the system, the machine should be brought to a complete stop in a safe location with the parking brake engaged.

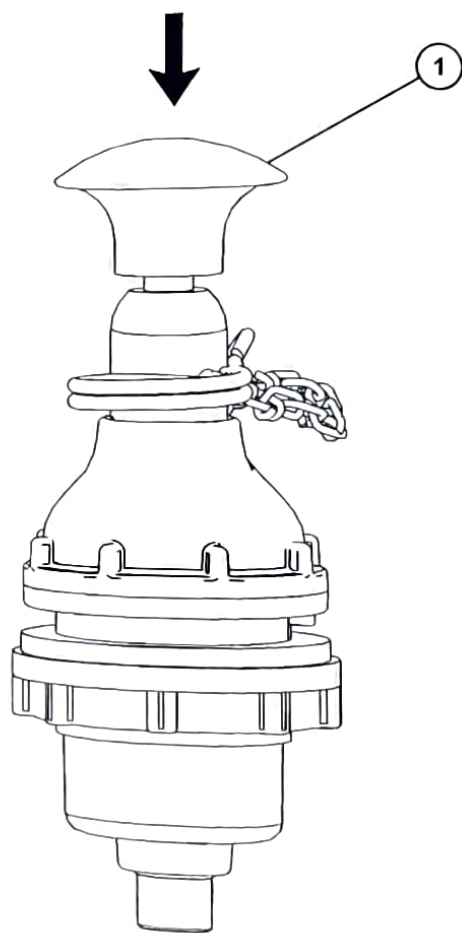

Illustration 260

g06256624

Typical example of fire suppression system manual actuator

(1) Electric Manual Actuator (Quantity may vary)

**Power LED (1)**

1. Green steady-on indicates normal external power
2. Amber pulsing indicates a power:

- Pulsing once every 30 seconds indicates an external power fault; sounder auto-silences after 10 minutes to conserve power.
- Pulsing once every 10 seconds indicates an internal power fault; sounder auto-silences after 10 minutes to conserve power.

**Note:** A power fault will continue for up to 72 hours as long as a fault exists or until unit powers down. Contact Authorized ANSUL Distributor for service

3. Off indicates no system power.

**Release and Detection LEDs (2)**

1. Off indicates normal status.
2. Amber pulsing with sounder indicates a fault condition.

**⚠ WARNING**

Personal Injury or death could result if the fire suppression system is not functioning properly. Ensure that the fire suppression system is in proper working order without any faults or damaged components. Immediately contact an authorized fire suppression distributor for any repairs before operating the machine.

**"Push To Activate / Alarm When LIT" LED/Button (3)**

- Pulsing twice per second indicates an Alarm Condition and Time Delay period starts countdown.
- Pulsing four times per second indicates the last 5 seconds of the Time Delay before suppression activation (release) occurs.
- Steady-on for 10 sec. indicates Release Activated.

**Note:** The sounder will always match the LED pulse rate

**"Delay/Reset/ Silence" Button (4) has 3 functions:**

- Restart Time Delay: Press and release to restart the time delay cycle during alarm condition, before the suppression system activates.
- Silence sounder (post discharge or fault notification) for 2 hours: Press and release to silence sounder; LED fault indication will continue until fault is cleared. Any new fault or detection event will reactivate sounder.
- Reset function is for Authorized ANSUL Distributor service technician.

Fill in the System information boxes below:



**Fill-In System Information (as installed)**

External Power Supply (vehicle battery, power panel, etc.): \_\_\_\_\_

---

Note: Internal backup power provides approximately 72 hours of power during normal operating conditions.

Selected Time Delay Period (seconds):  5     15

Pressure Switch Auxiliary Operation: \_\_\_\_\_

---



---

Illustration 261 g06411276

Use the following table to document manual actuator location information (as installed)

**Fill-In System Information (as installed)**

Electric or Pneumatic Manual Actuator Location(s):

---



---



---



---

Illustration 262 g06411297

**Fire Suppression-Manual Actuation**

**IN CASE OF FIRE:**

1. Safely bring machine to complete stop, set brake, and shut off engine.
2. Locate the system controller on the upper right-hand control panel.
3. Break visual seal and open guard door on the system controller.
4. Push the red "PUSH To Activate" button.
5. The fire suppression system will begin Activation.

**Note:** The red "PUSH To Activate" LED and sounder remain steady-on for 10 seconds during activation (release) of the fire suppression system. The red "PUSH To Activate" LED and sounder continue to pulse once every 10 seconds after the release of the fire suppression material is complete. If conditions allow for safe re-entry of the equipment, push the "DELAY/ Reset/Silence" button to silence the sounder for 2 hours.

6. Safely exit machine and stand-by with supplemental fire fighting equipment if there is re-ignition.

**In Case of Fire: Manual Actuation (Method 2)**

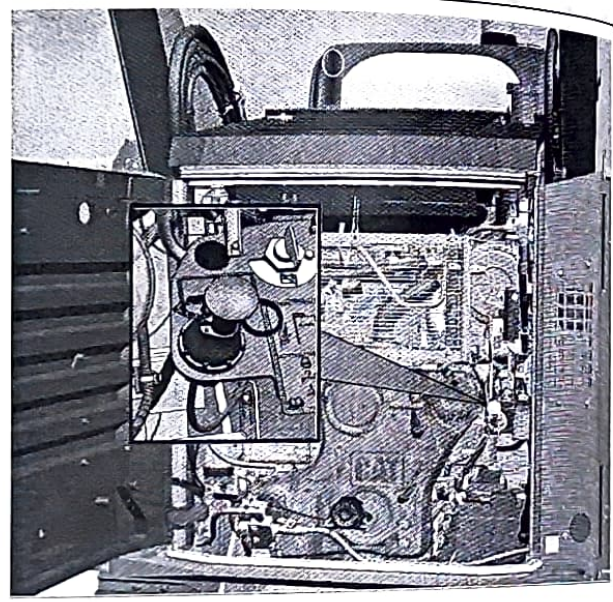

Illustration 263 g06489761

Machines built with the optional factory installed fire suppression systems, are equipped with a manual actuator located in the engine compartment on the right-hand side.

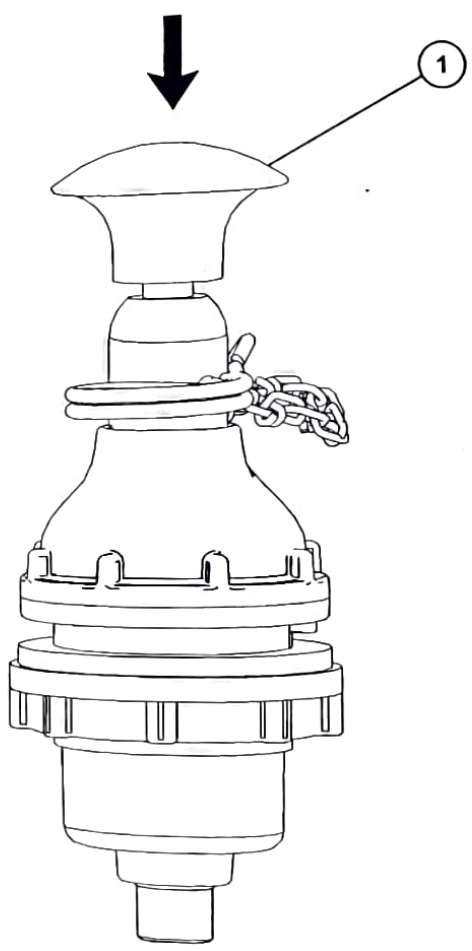

Illustration 264  
g06256624  
Typical example of fire suppression system manual actuator

- (1) Electric Manual Actuator (type and quantity may vary)
- 1. Safely bring equipment to complete stop, set brake and shut off engine.
- 2. Locate the manual actuator within the engine compartment on the right-hand side.
- 3. Trigger the manual actuator by pulling the safety ring pin and depressing the red button.
- 4. Stand-by with supplemental firefighting equipment if there was re-ignition.

**Fire Suppression-Automatic System Actuation**

**IN CASE OF FIRE:**

- 1. Detector registers alarm condition in hazard area and initiates the time delay notification on display module.

- 2. "PUSH To Activate / Alarm When Lit" , plus Detection 1 and/or Detection 2 LED plus sounder:
  - Pulse twice per second until the last 5 seconds of the Time Delay period.
  - Pulse four times per second during the final 5 seconds of the Time Delay period.

**Note:** To restart the Time Delay press and release the gray "DELAY/Reset/Silence" button before the suppression system activates.

- Remain steady-on for 10 seconds during activation (release) of the fire suppression material.
- Pulse once every 10 seconds after the release of the fire suppression material is complete.
- 3. When Time Delay period begins and the "PUSH To Activate" LED and sounder initiate their warnings, safely stop equipment, set the parking brake and shut off the engine.
- 4. Safely exit the equipment and stand-by with supplemental firefighting equipment if there is re-ignition.
- 5. If conditions allow for safe re-entry of the equipment, push the "DELAY/Reset/Silence" button to silence the sounder for 2 hours.

**Note:** In case of fire and/or system activation, contact your Cat Dealer and an authorized Ansul Distributor service technician before putting machine back into service.

**Note:** Inspect and service (as needed) the Fire Suppression System every 6 months or after an activation of the system. Contact an authorized ANSUL Distributor service technician for inspection and service of the fire suppression system. Refer to fire suppression manufacturer's instructions for additional information on troubleshooting, maintenance, and operation of system.



# Engine Starting

108224163

## Engine Starting

SMCS Code: 1000; 7000

### WARNING

Do not use aerosol types of starting aids such as ether. Such use could result in an explosion and personal injury.

Refer to Operation and Maintenance Manual, Cold-Weather Requirements to prepare the machine for operation in temperatures that are below 0 °C (32 °F). Follow the appropriate warm-up procedures when the machine is operated in temperatures that are below 0 °C (32 °F).

Machine preparation for cold weather includes using the correct hydraulic system oil. The factory fills the hydraulic system with 10W hydraulic oil which has a minimum operating temperature of -20 °C (-4 °F). If the machine will be operated at temperatures below -20 °C (-4 °F), the 10W oil must be replaced with 0W30 hydraulic oil to provide the proper oil viscosity. Refer to Operation and Maintenance Manual, "Lubricant Viscosities and Refill Capacities". Refer to Operation and Maintenance Manual, SEBU5898, "Cold-Weather Recommendations for Caterpillar Machines". Refer to Operation and Maintenance Manual, SEBU6250, "Caterpillar Machine Fluids Recommendations".

#### NOTICE

Keep the engine speed low until the engine oil pressure alert indicator goes out. If the alert indicator does not go out within ten seconds, stop the engine and investigate the cause before starting again. Failure to do so can cause engine damage.

#### NOTICE

If you fail to follow the steps described below, damage to the engine or damage to the hydraulic system may occur.

1. Fasten the seat belt.
2. Pull the armrests downward.
3. Before the engine is started, check for the presence of bystanders or maintenance personnel. Ensure that all personnel are clear of the machine. Briefly sound the forward horn before you start the engine.
4. Move the engine speed control knob to low idle.

5. Turn the engine start switch key to the ON position. On machines equipped with the Standard Display, wait for the cold starting aid alert indicator light to go out. On machines equipped with the Advanced Display, wait for the LCD display to load the Welcome screen. On any machine with security enabled, enter a valid PIN. Refer to Operation Maintenance Manual, "Operator Controls, Right Side Controls" for more information on the Anti-Theft Security System.

#### NOTICE

If the engine fails to start after 10 seconds, disengage the starter. Wait 30 seconds and repeat the procedure. Do not allow the starter motor to run continuously for more than 20 seconds.

6. Turn the engine start key to START position to start the engine. Release the key after the engine has started.

**Note:** If the machine is equipped with the optional Selectable Control Pattern feature, a control pattern must be selected before the parking brake can be disengaged. Refer to Operation and Maintenance Manual, "Operator Controls, Left Side Controls, and Operator Controls, Joystick Controls" for more information on the Selectable Pattern Control switch and available joystick control patterns.

7. Disengage the parking brake.
8. Run the engine for 5 minutes before performing the following procedure. Run the engine at half throttle. Raise the lift arms several feet and hold the work tool joystick control in the TILT BACK position for 30 seconds. Release the control for 30 seconds. Hold the work tool joystick control in the DUMP position for 30 seconds. Release the control for 30 seconds. Perform the procedure for 3 minutes.

**Note:** If you are operating the machine below 0 °C (32 °F), perform the procedure for 8 minutes.

#### NOTICE

Do not use the hydraulic interlock override function to warm up the machine.

9. Keep all personnel away from the machine. Move the machine slowly to an open area. Repeat Step 8 as you move the machine back and forth for 3 m (10 ft).

**Note:** More warm-up time may be required if the hydraulic functions are sluggish.

## Cold-Weather Requirements

Machine preparation for cold weather includes using the correct hydraulic system oil. The factory fills the hydraulic system with 10W hydraulic oil which has a minimum operating temperature of -20° C (-4° F). If the machine will be operated at temperatures below -20° C (-4° F), the 10W oil must be replaced with 0W30 hydraulic oil to provide the proper oil viscosity. Refer to Operation and Maintenance Manual, "Lubricant Viscosities and Refill Capacities". Refer to Operation and Maintenance Manual, "Cold-Weather Recommendations for Caterpillar Machines" SEBU5898. Refer to Operation and Maintenance Manual, "Caterpillar Machine Fluids Recommendations" SEBU6250.

Refer to the following table for requirements and recommendations for the engine when operating below -18° C (-0° F)

**Reference:** Refer to the Machine Price List for the appropriate kit part numbers.

Table 23

Cold-Weather Engine Requirements and Recommendations					
Models	Engine	Serial Number Ranges	Required		Recommended
			-18°C to -32°C (0°F to -25°F)	-33°C to -40°C (-26°F to -40°F)	-18°C to -40°C (0°F to -40°F)
226D3, 232D3, 239D3, 249D3	C2.2	All	SAE 0W -40 Engine Oil		Engine Block Heater #1 Diesel or Anti-Gel Additive Battery Disconnect Switch Kit
		All except PWN		Cold Climate Kit	
236D3, 242D3, 246D3, 262D3, 257D3, 259D3, 279D3, 289D3	C3.3B	All	SAE 0W -40 Engine Oil		Engine Block Heater #1 Diesel or Anti-Gel Additive Battery Disconnect Switch Kit 1000 CCA Battery
		KXL, HXS, KEZ, CW9, GK6, ME6, S7E, TE9, KC6, ZB2, RB9, JX9, PF6, W6E, Z9E, BT9		Rear Door Cover Kit	
272D3, 272D3 XE, 299D3, 299D3 XE	C3.8	All	SAE 0W -40 Engine Oil	Rear Door Cover Kit	Engine Block Heater #1 Diesel or Anti-Gel Additive Battery Disconnect Switch Kit 1000 CCA Battery

## Engine Torque Limited During DEF Thawing

**Note:** A 32.5% solution of DEF will begin to crystallize and freeze at -11° C (12° F). At 32.5%, both the urea and water will freeze at the same rate, ensuring that as it thaws, the fluid does not become diluted, or over concentrated. The freezing and thawing of DEF will not cause degradation of the product.



This is only applicable to the models that require Diesel Exhaust Fluid (DEF). When the DEF is frozen, there is no DEF circulating to cool the DEF injector. To prevent the DEF injector from damage, the engine torque is reduced by up to 20%. The message "Engine Derate - Protect against cold temperature" will appear on the monitoring screen of the Advanced Display. Once the DEF is thawed, full engine torque will return automatically. Refer to the engine's Systems Operation manual, DEF Dosing Control System for more information.

## Low System Battery Voltage Elevated Low Idle

The low system battery voltage elevated low idle feature will immediately raise the low idle engine speed slightly if the system battery voltage falls below a triggering threshold with the engine speed near low idle. This feature is intended to improve the reliability of charging system components like the alternator and battery and help compensate for increased electrical load resulting from user installed electrical components. The feature will be canceled by the operator when the engine speed is raised by the controls. This feature will automatically cancel if the system battery voltage rises above a predetermined threshold.

## Cool Engine Elevated Low Idle (Cold Start)

The cool engine elevated low idle feature will immediately raise the low idle engine speed slightly if the machine senses an ambient temperature or engine coolant temperature below certain thresholds while the parking brake is engaged, hydraulic lockout is engaged, and interlock override is disengaged. This feature is primarily associated with cold startup and is intended to accelerate the warmup of the engine and fluids and improve white smoke cleanup. The feature will be canceled by the operator when the parking brake is disengaged, hydraulic lockout is disengaged, and interlock override is engaged, or the engine speed is raised by the controls. The feature will automatically cancel if the ambient and engine coolant temperatures increase above certain thresholds.

## Cold Engine Elevated Low Idle (Parked Idle)

The cold engine elevated low idle feature will slowly increase the engine idle speed to a significantly higher speed when the machine has sat for several minutes with the parking brake is engaged, hydraulic lockout is engaged, and interlock override is disengaged, and the ambient or engine coolant temperature have fallen below certain temperature thresholds. This feature is intended to help prevent certain engine components from damage due to fluids freezing when the machine is left parked in idle. This feature will be canceled by the operator when the parking brake is disengaged, hydraulic lockout is disengaged, and interlock override is engaged. The feature will automatically cancel if the ambient or engine coolant temperature initiating the response increase above certain thresholds. This feature should not be confused with Diesel Particulate Filter Regeneration. Refer to "Diesel Particulate Filter Regeneration" for more information.

**Note:** There may be other machine conditions required to initiate or terminate any of the elevated low idle modes. Only the primary conditions are listed above.

## Turbocharger Protection Mode (Start Up)

**Note:** It is always recommended to start the engine with the engine speed control knob in the low idle position, and to follow the recommended engine starting & warm up procedures for best engine life.

The turbocharger protection mode helps ensure that proper turbocharger shaft lubrication is achieved before the turbocharger speed increases due to engine speed adjustment and/or load. This is normal and designed to protect vital engine components. This feature results in the following engine behavior relative to throttle position:

- The engine will remain in low idle hold for a few seconds at start-up, regardless of coolant temperature or position of the engine speed control knob or foot pedal.
- After low idle hold, the engine rpm will remain at low idle until either the engine speed control knob or foot pedal is adjusted slightly in either direction. When the engine rpm will begin to increase towards the desired setting.

The maximum engine rpm will be limited to predetermined values based on coolant temperature and driven via a non-adjustable software map. High Idle will not be available until coolant temperature reaches a safe operating threshold. This warm up period can vary between a few seconds and about a minute based on how cold the ambient temperature is.



# Operation

i07373299

## Operation Information

SMCS Code: 7000

### Fueling the Machine

#### WARNING

Ultra Low Sulfur Diesel (ULSD) poses a greater static ignition hazard than earlier diesel formulations, with a higher Sulfur content, which may result in a fire or explosion. Consult with your fuel or fuel system supplier for details on proper grounding and bonding practices.

#### WARNING

To avoid possible injury or death, do not smoke while in an area that contains flammable liquids.

All fuels, most lubricants, and some coolants are flammable.

Keep all fuels and lubricants stored in properly marked containers and away from unauthorized persons.

Fuel leaked or spilled onto hot surfaces or electrical components can cause a fire.

Store all oily rags or other flammable materials in a protective container in a safe place.

Remove all flammable materials such as fuel, oil, and other debris before they accumulate on the machine.

Do not expose the machine to flames, burning brush, etc., if at all possible.

The fuel fill may either be located inside the engine compartment on the right-hand side, or outside the machine at the left rear corner of the frame. Replace the fuel cap and lock into place after fueling the machine.

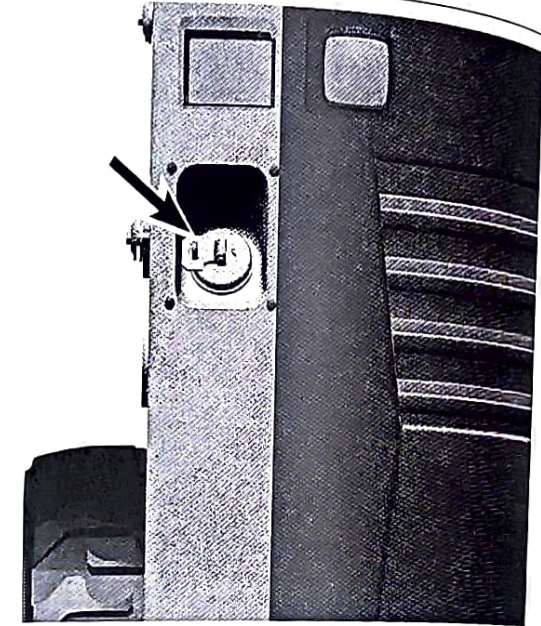

Illustration 265

g06355066

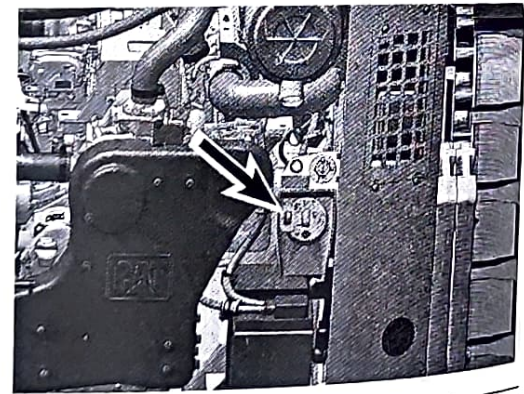

Illustration 266

g06355060

## General Information

**Note:** The 299D3 XE Land Management models have two fuel tanks, one on either side of the rear corners of the machine. The fuel cap for each tank is located on the top of the tank, under a hinged guard.

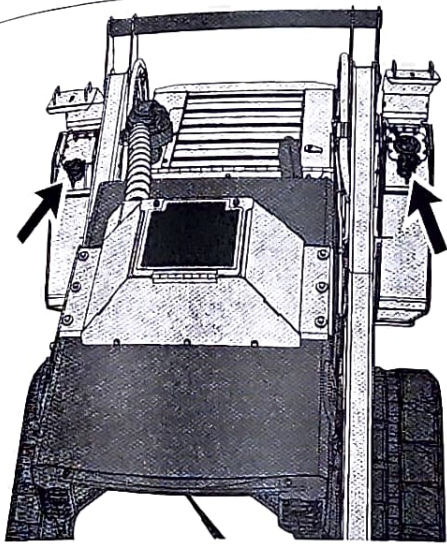

Illustration 267

g06407687

To prevent injury, make sure that no people are working on the machine or near the machine. To prevent injury, keep the machine under control at all times.

Reduce engine speed when you maneuver in tight quarters or when you are going over a hill.

1. Adjust the operator seat.
2. Fasten the seat belt.
3. Lower the armrests.
4. Start the engine and allow the machine to warm up. Refer to Operation and Maintenance Manual, "Engine Starting".
5. Disengage the parking brake.
6. Raise all lowered work tools and attachments to negotiate any obstacles.
7. Smoothly move the speed and direction control for the desired direction and speed.

Do not allow the machine to overspeed when you go downhill. Move the joystick toward the NEUTRAL position to reduce the speed of the machine when you are going downhill. For additional information, refer to "Operating on a Slope".

Always put the heaviest end of the machine uphill when you are working on an incline.

Fully lower the loader arms onto the stops when you are digging with the machine. Digging with the loader arms in the fully lowered position will transfer the stress that is placed on the loader arm into the frame.

**NOTICE**

The use of this machine in certain applications can cause premature wear and/or failure of the tracks. Applications that may cause premature wear and/or failure of the tracks include: use in rocky terrain, use in gravel, use in concrete demolition and use in terrain where metal debris is present.

Damage to the tracks that is caused from using the machine in these conditions is not covered under warranty.

Avoid any situation that causes the tracks of the machine to spin on the ground. Avoid spinning the tracks to extend the life of the track.

**Note:** While you use steel tracks that go over the tires, the work tools may not engage the work tool coupler properly. Work tools may not properly engage the ground. **Steel tracks that go over the tires should only be used with pneumatic tires.** The loader arms may contact the steel tracks which may damage to the machine. When you use steel tracks that go over the tires, the interval for checking the drive chains should be reduced to every 100 Service Hours. Refer to Operation and Maintenance Manual, "Drive Chain Tension - Check/Adjust" for proper service of the drive chain. The use of rubber tracks that go over the tires is not recommended.

**Operating on a Slope**

When necessary to travel across a slope, never exceed a slope that is greater than 3 to 1 (18.4°).

When possible, avoid operating the machine across a slope. When possible, operate the machine up a slope and down a slope. Never exceed a slope that is greater than 25 degrees for continuous fore/aft slope operation and 35 degrees intermittent fore/aft operation. The engine has an intermittent rating of 2 minutes. Do not turn the machine while you are operating on a slope.

**NOTICE**

When it is necessary to operate the machine on a slope, keep bucket loads light in order to decrease the possibility of derailing the tracks.

**NOTICE**

If the correct method for turning is not followed, the tracks may derail.

When necessary to travel across a slope, the following steps should always be followed:



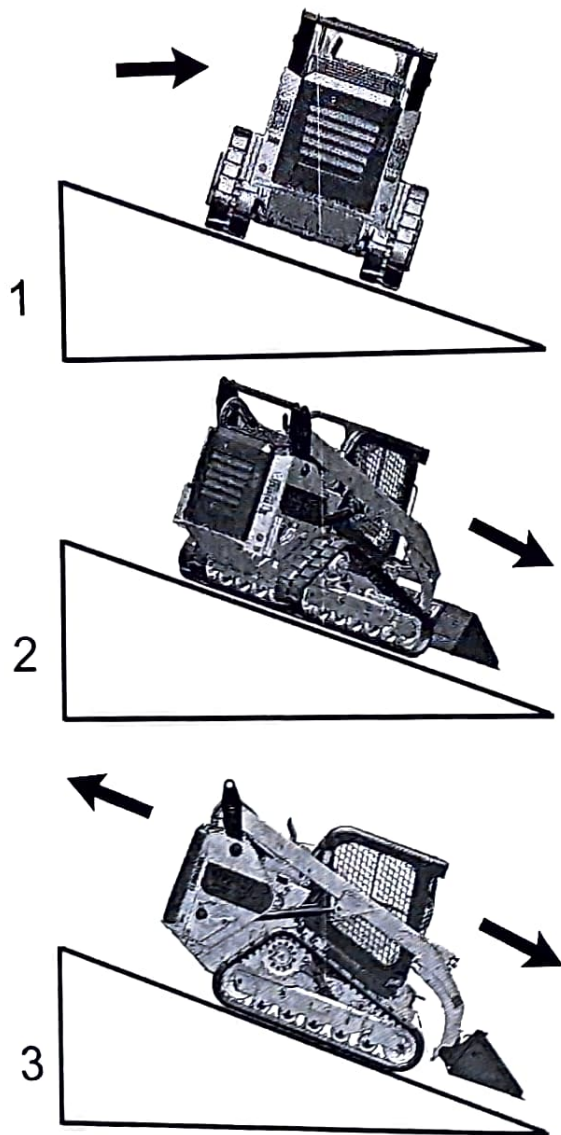

Illustration 268

g06355085

1. Stop the machine. Turn the machine slowly while you are backing down the slope.

**Note:** Do not back up a hill to turn.

2. Position the machine so that the front of the machine faces the direction for travel that is desired.

## Operating on a Transition

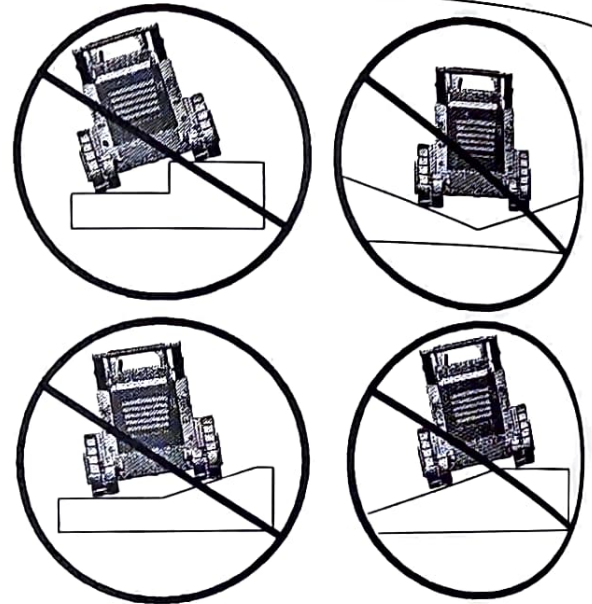

Illustration 269

g06355444

### NOTICE

Avoid operating this machine on transitions. Operating this machine on transitions may cause the tracks to derail.

When the machine is operated over a transition, the tracks may not be supported fully.

When the tracks are not supported fully, the wheels may ride on top of the drive lugs of the tracks. The track will derail if you continue to travel over the transition.

If you must travel over a transition, travel the machine at 90° to the transition. Do not perform hard turns or fast turns when you are operating the machine over the transition.

## Counterrotate turn

For maximum life of the undercarriage, use more gradual turns while you slowly move forward or reverse. Gradual turns will help minimize wear on the track and wear on the wheels. Only use counterrotate turns if necessary. Sharp turns will increase the wear on the components of the undercarriage.

i07678674

## Quick Disconnect Couplings Operation

SMCS Code: 5057

Release any stored hydraulic fluid pressure in the system before connecting or disconnecting the work tool's hydraulic lines. Refer to Operation and Maintenance Manual, Work Tool Coupler Operation Hydraulic System Pressure Relief for the proper method for your machine.

Remove the dust caps from the couplings which will be used and assemble to keep clean.

Inspect the couplings for damage and replace any coupling believed to be damaged. Never operate the machine with a damaged quick disconnect coupling.

Ensure that the faces of the coupling halves are clean to prevent dirt inclusion.

**Note:** Identify the style of couplings on the machine and follow the appropriate procedure below.

## Push-to-Connect Style Coupling

To connect the work tool, hold the faces of the male and female halves flatly together and push the work tool's hose in until the female coupling's locking sleeve snaps forward completely. Pull back on the hose forcefully to ensure that the coupling halves are locked together.

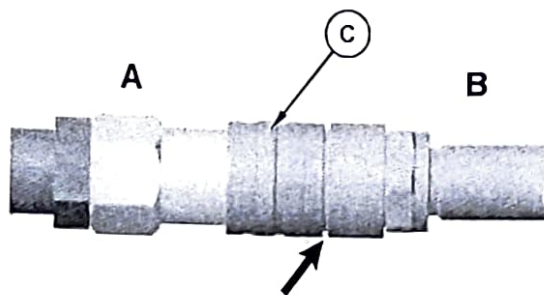

Illustration 270

g06392610

Improperly Coupled

- (A) Male
- (B) Female
- (C) Locking Sleeve

Locking sleeve (C) has not snapped forward. There is no audible "Click".

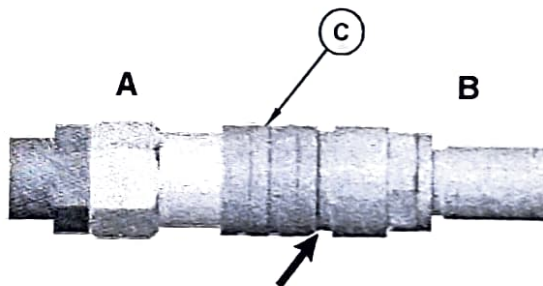

Illustration 271

g06392628

Properly Coupled

- (A) Male
- (B) Female
- (C) Locking Sleeve

Locking sleeve (C) has snapped forward. There is an audible "Click".

To disconnect the work tool, push the hose further into the machine's coupling block (about 3 mm) and hold in this position for about 5 seconds to relieve the hydraulic pressure.

Slide the female coupling's locking sleeve back fully while pulling the work tool's hose away from the machine until they separate.

Ensure that the dust caps are clean and install on open couplers to prevent system contamination.



**Note:** The couplers may be extremely hot after use. Wear suitable protection

## Screw-to-Connect Style Coupling

To connect the work tool, screw the male and female halves together by turning the locking sleeve on the female coupler. During connection the machine-side locking sleeve is turned counterclockwise and the work tool-side locking sleeve is turned clockwise.

Once the halves are coupled fully, the locking sleeve will snap forward over the locking ring, and an audible "Click" may be heard. Do not put into service if the locking sleeve does not slide forward abruptly, completely covering the locking ring. There should be no visible gap between the male and female halves before use.

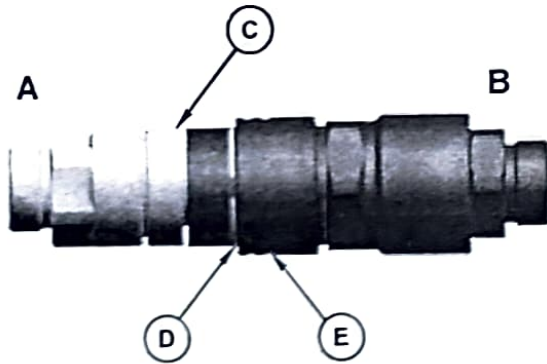

Illustration 272

g06392642

### Improperly Coupled

- (A) Male
- (B) Female
- (C) Visible Gap
- (D) Exposed Locking Ring
- (E) Locking Sleeve

Locking sleeve (E) has not snapped forward. There is no audible "Click".

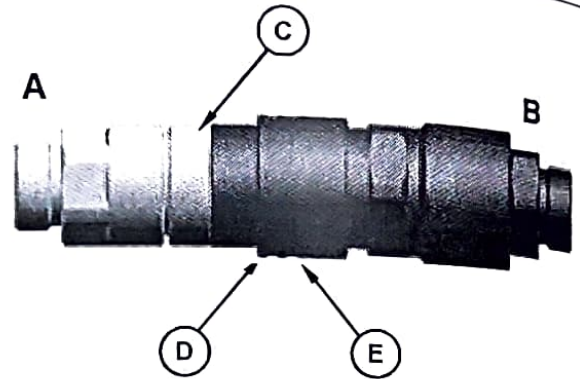

Illustration 273

g06392678

### Properly Coupled

- (A) Male
- (B) Female
- (C) No Visible Gap
- (D) No Visible Locking Ring
- (E) Locking Sleeve

Locking sleeve (C) has snapped forward. There is an audible "Click".

To disconnect the work tool, slide the locking sleeve back and unscrew the couplers until separate. It may be necessary to slightly rescrew the coupler halves together first before the locking sleeve will slide back freely.

During disconnection the machine-side locking sleeve is turned clockwise and the work tool-side locking sleeve is turned counterclockwise.

Ensure that the dust caps are clean and install on open couplers to prevent system contamination.

**Note:** The couplers may be extremely hot after use. Wear suitable protection. A specially sized wrench is available to aid disconnection. Contact your Cat Dealer for more information.

i07373495

## Work Tool Coupler Operation

SMCS Code: 6129; 7000

### **WARNING**

Improper Attachment of the Work Tool could result in injury or death.

Do not operate the machine without confirmation that the coupler pins are fully engaged. Follow the operating procedures in the Operation and Maintenance Manual.

## Hydraulic System Pressure Relief

These procedures are used to relieve the system pressure that may be stored in the machine's auxiliary hydraulic lines. Relieve the hydraulic system pressure before attaching or removing work tools or servicing the hydraulic system.

### Coupling Method (Primary)

If the machine is equipped with connect-under pressure style couplings, push the face of the coupling inwards (towards machine) and hold for 5 seconds. This may also be accomplished by pushing the couplers of the machine and work tool together to displace the machine's coupling face.

### Joystick Method (Alternate)

The machine's system pressure may be relieved by operating the auxiliary hydraulic controls in each direction several times when the following conditions are met: operator is in the seat with the armrests down, the engine key start switch is in the ON position but the engine is not running, and the parking brake has been released.

### Pressure Relief Knob Method (Alternate)

**Note:** Pressure Relief Knob is only available on XE machines.

Pull the knob out & then tilt the knob up and hold for 5 seconds. See "Auxiliary Hydraulic Controls".



Illustration 274

g06407704

## Attaching the Work Tool

**Note:** Before you install the work tool, inspect the coupler and the work tool mounting bracket for any wear or for any damage. Ensure that the work tool mounting bracket and the face of the coupler are clean. Ensure that the coupler has no accumulation of material. Refer to Operation and Maintenance Manual, "Quick Coupler - Clean/Inspect" and Operation and Maintenance Manual, "Work Tool Mounting Bracket - Inspect" for inspection procedures.

1. Position the work tool on a level surface. Move the hydraulic lines (if equipped) for the work tool and electrical lines (if equipped) away from the work tool mounting bracket.



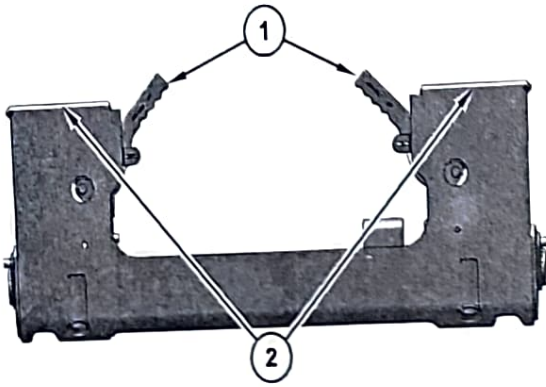

Illustration 275

g06408653

2. If the machine is equipped with a manual quick coupler, ensure that the levers(1) for the coupler are in the DISENGAGED position. If the machine is equipped with an electrical or hydraulic quick coupler, refer to Operation and Maintenance Manual, "Operator Controls" for details on the location and the operation of the coupler control.
3. Enter the machine.
4. Fasten the seat belt and lower the armrests.
5. Start the engine.
6. Disengage the parking brake.
7. Tilt the quick coupler assembly forward.

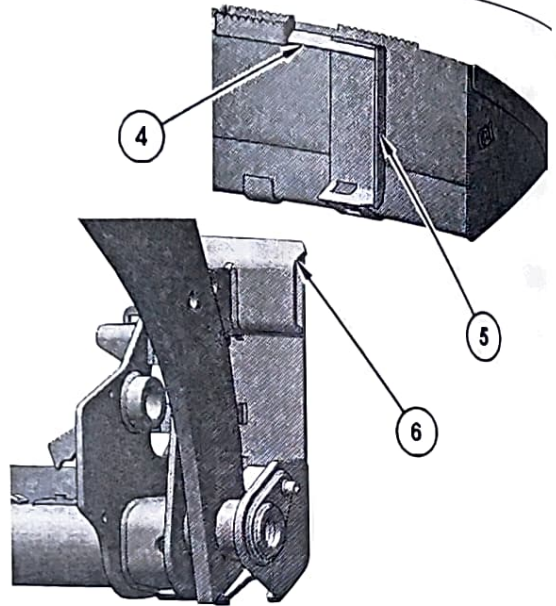

Illustration 276

g06408630

8. Align the quick coupler assembly (6) between the outer plates (5) of the mounting bracket. Move the quick coupler assembly under the angled plate (4) of the mounting bracket and rack back the work tool.
9. Fully lower the loader arms.

**! WARNING**

Improper attachment of the work tool could result in injury or death. If the work tool touches the ground, the work tool may move away from the coupler. Do not allow the work tool to touch the ground until the coupler pins are fully engaged.

10. Turn the engine start switch key to the OFF position to stop the engine.
11. Exit the machine.

**Note:** If you are installing a material handling arm that is not equipped with the optional center step, do not exit the machine. A second person needs to perform steps 12 through step 14.

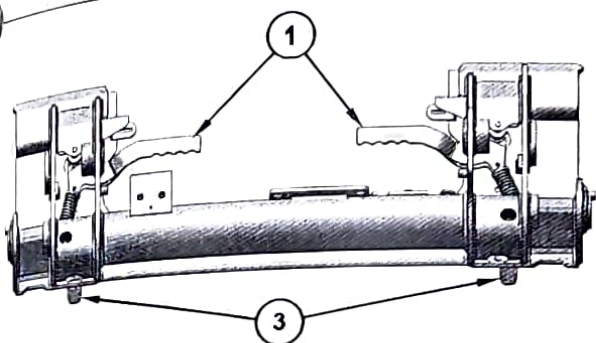

Illustration 277

g06408603

12. Engage the coupler pins(3). If the machine is equipped with a manual quick coupler, ensure that the levers(1) for the coupler are in the ENGAGED position. If the machine is equipped with a hydraulic coupler, refer to Operation and Maintenance Manual, "Operator Controls" for details on engaging the coupler pins.

13. If the work tool requires hydraulics, refer to the following procedure to connect the hydraulic hoses.

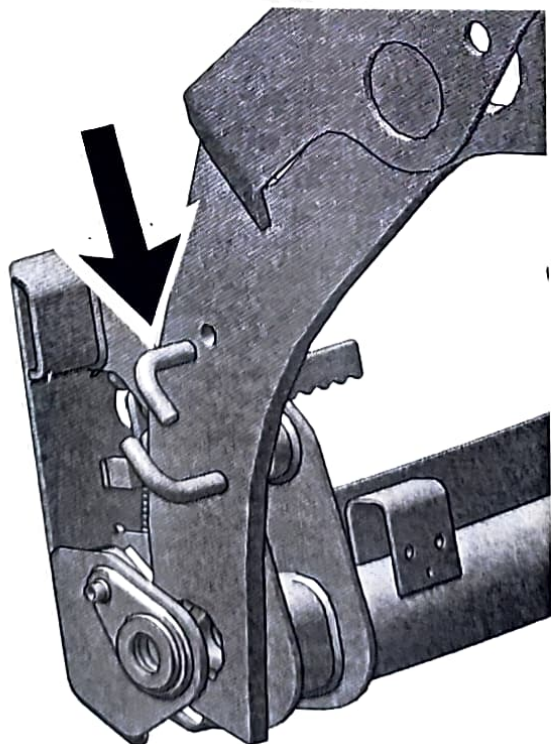

Illustration 278

g06408595

a. Route the hydraulic hoses through the hose guide on the machine to prevent damage to the

hoses. Not all work tools require the hydraulic hoses to be routed through the hose guide. The work tool Operation and Maintenance Manual will inform you if the hydraulic hoses need to be routed through the hose guide. Cat work tools require the hoses to be routed through the hose guide.

- b. Ensure that the quick connect couplers are clean. Visually inspect the couplers for corroding, cracking, damage, or excessive wear. Replace the couplers if necessary.
- c. Relieve the system pressure that may be stored in the machine's auxiliary hydraulic lines. See Hydraulic System Pressure Relief.
- d. Connect the auxiliary hydraulic hoses for the work tool to the machine. Refer to section in this Operation and Maintenance Manual, Quick Disconnect Couplings Operation for a complete explanation on the machine's hydraulic and electrical outputs. Full connection is made when the sleeve of the female coupler slides forward.
- e. If the work tool is equipped with electrical lines, then route the electrical lines with the hydraulic hoses. Connect the wire harness to the electrical connector (EC) on the host machine. Check the connections to ensure that the connections are properly secured. Check the connections on the work tool to ensure that the connections are in the correct receptacle.

**Note:** If your High Flow work tool does not have a wiring harness, a Jumper Plug should be installed on the electrical plug for the work tool control. Without this Jumper Plug, the machine will not provide high flow to the work tool. Consult your Cat dealer for the current part number for the Jumper Plug.

- f. If the work tool is equipped with a water line, then connect the water line from the work tool to the connector on the machine. Move the water line to a position that is away from the work tool mounting bracket.



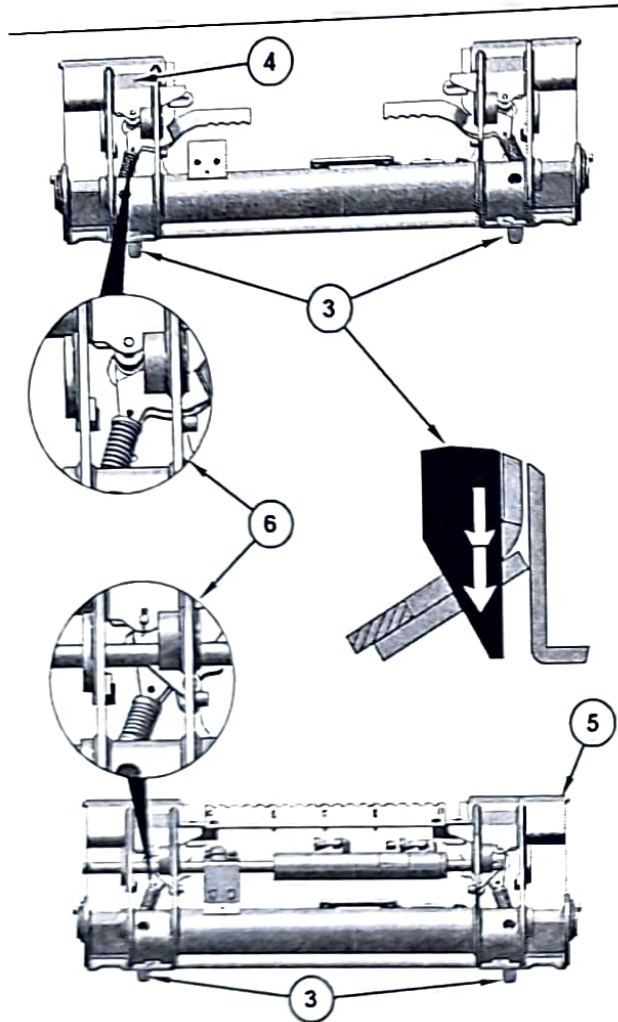

Illustration 279

g06408578

- (3) Coupler Pins
- (4) Manual Work Tool Coupler
- (5) Electric or Hydraulic Work Tool Coupler
- (6) Lever for the Coupler Pin

14. Visually ensure that both coupler pins (3) are extending out of the holes in the work tool mounting bracket.
15. Use the following procedure to verify engagement of the coupler pins.
  - a. Enter the machine.
  - b. Fasten the seat belt and lower the armrests.
  - c. Start the engine.
  - d. Disengage the parking brake.
  - e. Raise the work tool off the ground.
  - f. Visually inspect the coupler pins (3) to ensure that the pins are fully extended through the work tool.

g. Visually inspect the lever (6) that holds the coupler pins to ensure that the lever is in the proper position.

h. Activate the tilt control to tilt the work tool downward.

i. Apply down pressure on the work tool.

**Note:** The work tool Operation and Maintenance Manual will inform you if forward pressure should not be applied on a work tool.

j. Move the machine backward. Ensure that the coupler pins do not disengage from the work tool.

16. Test the work tool for leaks and for proper operation.

## Removing the Work Tool

### **! WARNING**

Disengaging the coupler pins will release the work tool from control of the operator.

Serious injury or death may result from disengaging the work tool when it is in an unstable position or carrying a load.

Place the work tool in a safe position before disengaging the coupler pins.

### NOTICE

Auxiliary hoses for work tools must be disconnected before the Hydraulic Quick Coupler is disengaged.

Pulling the work tool with the auxiliary hoses could result in damage to the host machine or the work tool.

1. Position the machine on level ground.
2. Lower the work tool to the ground.
3. Rack back the work tool until the work tool is slightly off the ground.
4. Turn the engine start switch key to the OFF position to stop the engine.
5. If the work tool requires hydraulics, the hydraulic system pressure must be released.
6. Relieve the system pressure that may be stored in the machine's auxiliary hydraulic lines. See Hydraulic System Pressure Relief.
7. Disconnect the auxiliary hydraulic hoses for the work tool from the machine. Refer to Quick Disconnect Couplings Operation.

**Note:** If protective caps are available, clean the caps thoroughly and install protective caps over the quick connect couplers.

8. If hoses are routed through the hose guide, remove the hoses from the hose guide. Move the hoses to a position that is away from the work tool mounting bracket.

**Note:** Connect the hoses for the work tool together. Connecting the hoses together will reduce the probability of contaminating the hydraulic system. Connecting the hoses together will reduce the buildup of pressure in the hoses. Connecting the hoses together will ease the connection of the hoses to the machine.

9. If the work tool is equipped with an electrical line, then disconnect the wire harness from the connector on the machine. If protective caps are available, install protective caps over the electrical connectors.

10. If the auxiliary electrical line is routed through the hose guide, remove the line from the hose guide. Move the auxiliary electrical line to a position that is away from the work tool mounting bracket.

11. If the work tool is equipped with a water line, then disconnect the water line from the connector on the machine. Move the water line to a position that is away from the work tool mounting bracket.

**Note:** If you are removing a material handling arm that is not equipped with an optional center step, do not exit the machine. A second person needs to perform step 12.

12. Disengage the coupler pins. If the machine is equipped with a manual quick coupler, ensure that the levers for the coupler are in the DISENGAGED position. If the machine is equipped with an electrical or hydraulic quick coupler, refer to Operation and Maintenance Manual, "Operator Controls" for details on disengaging the coupler pins with the coupler control.

13. Enter the machine.

14. Fasten the seat belt and lower the armrests.

15. Start the engine.

16. Disengage the parking brake.

17. As you slowly back away from the mounting bracket, tilt the quick coupler assembly forward until the top of the quick coupler assembly clears the angled plate.

18. Back away from the work tool.

## Removing the Work Tool if the Hydraulic Quick Coupler Malfunctions

### WARNING

Disengaging the coupler pins will release the work tool from control of the operator.

Serious injury or death may result from disengaging the work tool when it is in an unstable position or carrying a load.

Place the work tool in a safe position before disengaging the coupler pins.

### NOTICE

Auxiliary hoses for work tools must be disconnected before the Hydraulic Quick Coupler is disengaged.

Pulling the work tool with the auxiliary hoses could result in damage to the host machine or the work tool.

**Note:** The hydraulic quick coupler only works while the engine is running, the hydraulic interlocks are made, and the machine has hydraulic power.

Using suitable blocking material, block the machine to ensure it does not move unexpectedly.

If the hydraulic quick coupler fails to function due to loss of machine electrical or hydraulic power, slightly open the hydraulic lines at the service connectors under the lift arm cross member. Provide a means to capture any hydraulic fluid in a suitable catch container. Insert a pair of 3/8" square drivers into the square openings of the linkage flags and rotate each towards the centerline of the machine to disengage the work tool retention pins from the work tool.



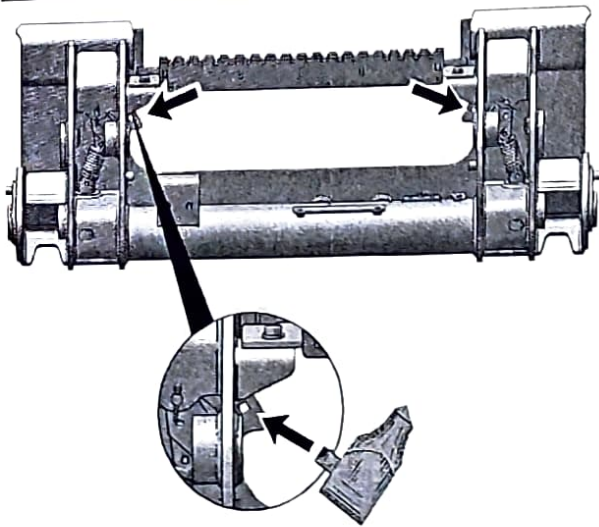

Illustration 280

g06408674

with 3/8" square driver rotate towards centerline

## Material Handling Arm Operation

SMCS Code: 6542; 6700; 7000

i07695485

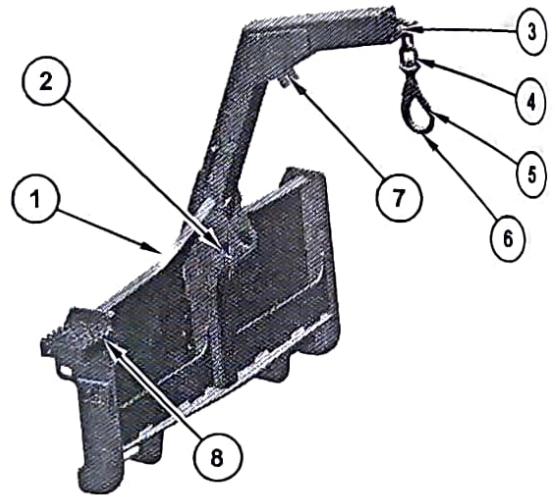

Illustration 281

g06397626

- (1) Location of Optional Center Step
- (2) Tie-Down Point
- (3) Lifting Point 2
- (4) Shackle
- (5) Hook Clasp
- (6) Hook
- (7) Lifting Point 1
- (8) Stored location of Position Lock Pin

Inspect the material handling arm and the attachments for wear and damage. Ensure that the load is properly attached to the material handling arm before you operate the machine.

**Note:** The physical size and the weight of the load determines the lifting point that is appropriate. Whenever it is possible, use the lifting point 1. This will improve the stability and this will reduce the movement of the load. Refer to the Operation and Maintenance Manual, "Material Handling Arm Rated Load" for the limitations on the weight.

**Note:** Use only Caterpillar 9V-2714 Hook and Caterpillar 9V-2715 Shackle to attach a load to the material handling arm. Never use an open hook. Use a line that is rated for 2.5 times the weight of the load.

**WARNING**

Do not allow anyone to be near a suspended load unless the position lock pin is installed. If the lift arms must be raised to handle a tall load, do not allow anyone to be near the suspended load unless the lift arms are blocked. Failure to follow the instructions or heed the warnings could result in injury or death.

**Two Person Operation****Attaching A Load**

1. Verify that the load does not exceed the weight limit. Refer to the Operation and Maintenance Manual, "Material Handling Arm Rated Load" for the rated load capacities.
2. Keep all personnel out of the work area at all times, except when you are attaching or removing a load.
3. Enter the machine. Start the engine.
4. Disengage the parking brake.

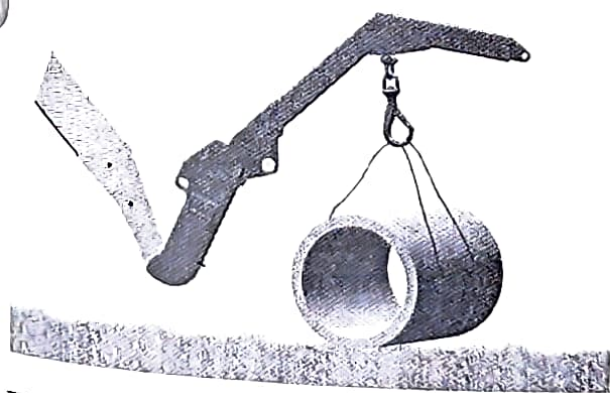

Illustration 282

g06399845

5. Keep the loader arms in the fully lowered position. Slowly position the material handling arm until either lifting point 1 or the lifting point 2 is directly above the load.
6. Tilt the material handling arm forward until the hook is slightly higher than the load in order to minimize swinging of the load.
7. Stop the engine.
8. Wait as the second person attaches the load securely to the hook. The second person needs to ensure that the hook clasp is in the locked position.
9. Ensure that ALL personnel have left the work area.

10. Start the engine.
11. Disengage the parking brake.
12. Slowly tilt back the material handling arm until the material handling arm is fully tilted back.
13. Stop the engine.

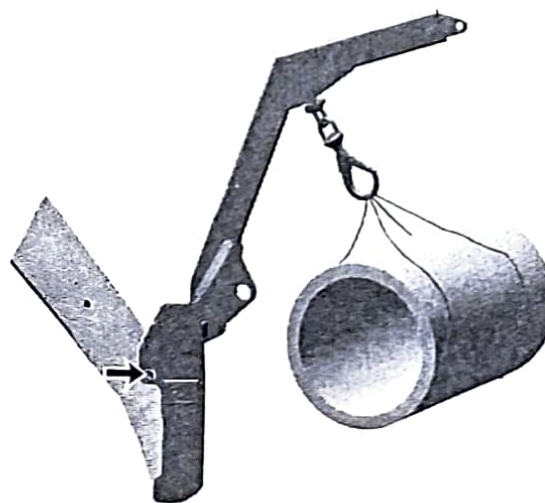

Illustration 283

g06399849

14. Wait as the second person installs the position lock pin through the hole in the material handling arm and the hole in the loader arm of the machine.

**Note:** This will prevent the material handling arm from tilting forward.

15. Wait as the second person secures the load to the tie-down points with a suitable line in order to minimize load swing.

**Note:** Do not move the load when you are securing the load. Do not pull the load toward the material handling arm when you are securing the load to the tie-down points.

16. Wait as the second person removes the position lock pin. Wait as the second person places the pin in the STORED position on the material handling arm.

**Removing a Load**

1. Slowly tilt back the material handling arm until the material handling arm is fully tilted back. Lower the loader arms fully.
2. Stop the engine.



3. Wait as the second person installs the position lock pin through the hole in the material handling arm and the hole in the loader arm of the machine.
4. Wait as the second person removes the line that secures the load to the tie-down points.
5. Wait as the second person removes the position lock pin. Wait as the second person places the pin in the STORED position on the material handling arm.
6. Remove all personnel from the work area.
7. Start the engine.
8. Disengage the parking brake.
9. Lower the load to the ground.
10. Stop the engine.
11. Wait as the second person removes the load from the hook.
12. Remove all personnel from the work area.
13. Start the engine.
14. Disengage the parking brake.
15. Slowly tilt back the material handling arm until the material handling arm is fully tilted back.
16. Back away from the load.

## One Person Operation

**Note:** The material handling arm must be equipped with a center step in order to do the one person operation.

### Attaching the Load

1. Verify that the load does not exceed the weight limit. Refer to the Operation and Maintenance Manual, "Material Handling Arm Rated Load" for the rated load capacities.
2. Keep all personnel out of the work area at all times, except when you are attaching or removing a load.
3. Enter the machine. Start the engine.
4. Disengage the parking brake.



Illustration 284

g0639845

5. Keep the loader arms in the fully lowered position. Slowly position the material handling arm until either lifting point 1 or lifting point 2 is directly above the load.
6. Tilt the material handling arm forward until the hook is slightly higher than the load in order to minimize swinging of the load.
7. Stop the engine. Exit the machine.
8. Attach the load securely to the hook. Ensure that the hook clasp is in the LOCKED position.
9. Keep all personnel out of the work area.
10. Enter the machine. Start the engine.
11. Disengage the parking brake.
12. Slowly tilt back the material handling arm until the material handling arm is fully tilted back.
13. Stop the engine. Exit the machine.

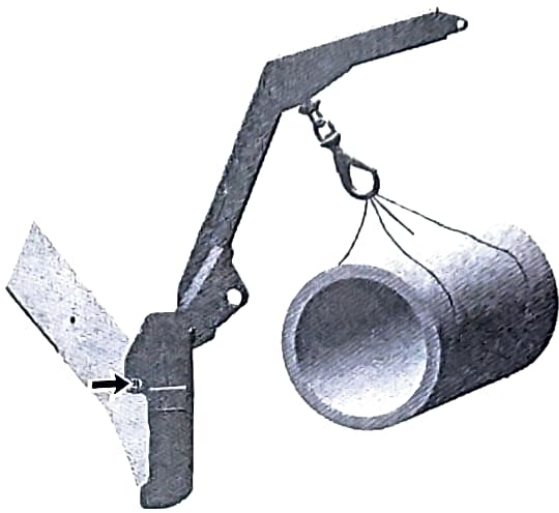

Illustration 285 g06399849

14. Install the position lock pin through the hole in the material handling arm and the hole in the loader arm of the machine.
  15. Secure the load to the tie-down points with a suitable line in order to minimize load swing.
- Note:** Do not move the load when you are securing the load. Do not pull the load toward the material handling arm when you are securing the load to the tie-down points.
16. Remove the position lock pin and place the pin in the STORED position on the material handling arm.

### Removing a Load

1. Fully tilt back the material handling arm. Fully lower the loader arms.
2. Stop the engine. Exit the machine.
3. Install the position lock pin through the hole in the loader arm of the machine.
4. Remove the line that secures the load to the tie-down points.
5. Remove the position lock pin and place the pin in the STORED position on the material handling arm.
6. Keep all personnel out of the work area.
7. Enter the machine. Start the engine.
8. Disengage the parking brake.

9. Lower the load to the ground.
  10. Stop the engine. Exit the machine.
- Note:** Make sure that the load is stable.
11. Remove the load from the hook.
  12. Keep all personnel out of the work area.
  13. Enter the machine. Start the engine.
  14. Disengage the parking brake.
  15. Slowly tilt back the material handling arm until the material handling arm is fully tilted back.
  16. Back away from the load.

### Traveling with a Load

1. Ensure that all personnel have left the work area.
2. Start the engine.
3. Disengage the parking brake.
4. Raise the load so that the load is slightly off of the ground.
5. Slowly travel to the destination. Keep the load as close to the ground as possible. Travel up slopes with the load uphill. Travel down slopes with the load uphill. Do not travel across slopes.

08483536

## Pallet Forks Operation

SMCS Code: 6700; 7000

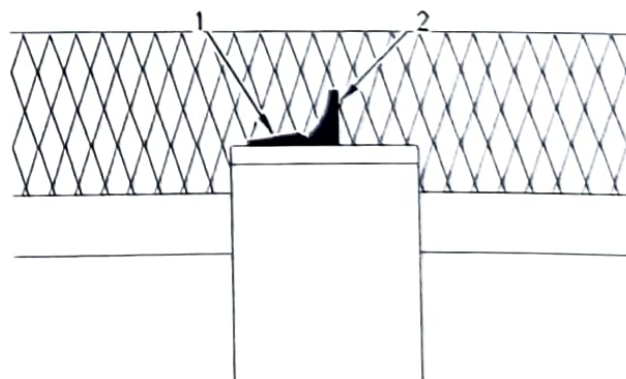

Illustration 286 g00955917

The "type 1" pin that is in the UNLOCKED position (2) and the LOCKED position (1).



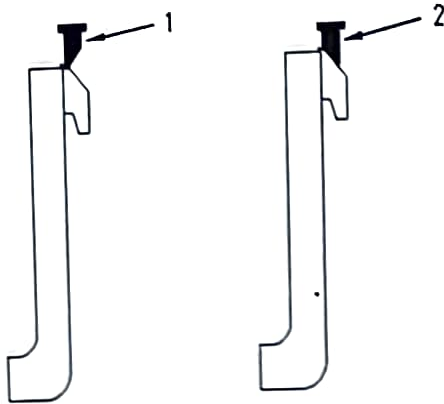

Illustration 267

g00955964

The "type 2" pin that is in the UNLOCKED position (1) and the LOCKED position (2).

1. Put the fork tines in the UNLOCKED position. Space the fork tines as far as possible from each other.
2. Put the fork tines in the LOCKED position.
3. Slowly, move the machine into position and engage the load. The machine should be square with the load. Space the forks evenly between the pallet stringers.
4. Move the machine forward until the load contacts the carriage.
5. Lift and lower the load carefully.
6. Carefully lower the load while you tilt the forks back to the travel position.

Travel with the load as low as possible while you still maintain ground clearance.

Travel with the load uphill on upgrades and on downgrades.

### Pallet Fork Tine Operation

1. Place the lift arms fully down and adjust the coupler tilt until the front face of the fork carriage assembly is vertical.

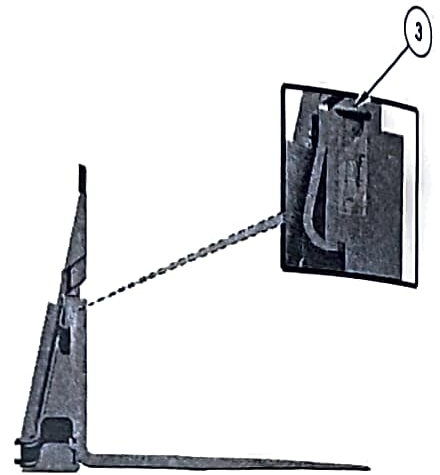

Illustration 288

g06673401

2. On the tine, unlock the pin (3).
3. Move the tine to the desired position by applying side force, alternating between the top or bottom of the tine.
4. Once close to the desired position, lock the pin (3) on the tine and continue moving the tine until the pin locks down into one of the upper carriage rail notches.
5. Adjust the tine as needed to confirm that tine is in a vertical position from the front and side views.

6. Repeat steps 2 - 5 for the second tine.

107695477

# Angle Blade Operation

SMCS Code: 6060; 7000

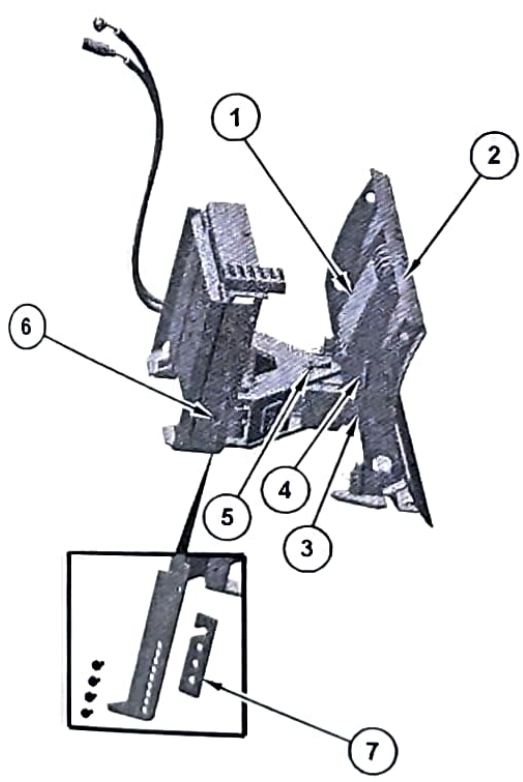

4. If the blade cutting edge does not remain parallel to the ground, the height of the blade needs to be adjusted. Use the following steps in order to adjust the height:
  - a. Lower the blade and the frame onto adjustable stands.
  - b. Stop the engine and remove the ignition key.
  - c. Remove the bolts (6) for adjusting the height.
  - d. Move the frame to the desired height.
  - e. Ensure that the shims are installed. Install the bolts for adjusting the height. Tighten the bolts to a torque of  $270 \pm 40 \text{ N}\cdot\text{m}$  ( $199 \pm 30 \text{ lb ft}$ ).
  - f. In order to test the adjustment, start the engine.
  - g. Repeat steps 2 and 3.

## Tilt Lock

The angle blade has two modes of operation:

- Locked
- Spring load trip

In order to lock the blade, install the locking pin (4). In the LOCKED position, the blade can be used for heavy operations. The blade will not tilt with the locking pin in the LOCKED position.

There may be lighter operations that allow the blade to tilt. Remove the locking pin and store the locking pin in the cab. This will help prevent damage to the blade or to the frame. If the plowing overcomes 306 kg (675 lb) of spring force, the top of the blade will tilt forward.

107545896

Illustration 289

g06399841

## Height Adjustment

In order to properly adjust the height of the blade, use the following procedure:

1. Start the engine.
2. Position the blade so that the vertical pivot pin (5) is in the VERTICAL position.
3. Move the angle of the blade fully from one side to the other side. The blade cutting edge should remain parallel to the ground.

## Work Tool Operation

SMCS Code: 6700; 7000

The following table describes the functionality of approved Cat work tools.

Refer to Operation and Maintenance Manual, "Operator Controls, Joystick Controls, and Operator Controls, Auxiliary Hydraulic Controls" for the location and operation of the joystick controls that are referenced below.

**Note:** All the work tool functions that are described below are viewed as the operator seated in the machine.

Operate the machine and the work tool slowly in an open area. Check for proper operation of all controls and all protective devices on the machine and the work tool.



**Note:** During initial operation, unexpected motion may occur due to air in the hydraulic system. Cycle the hydraulic system approximately five times to purge air out of the circuit. You may need to add hydraulic oil to the machine after the machine fills the hydraulic circuits of the work tool. Refer to Operation and Maintenance Manual, "Hydraulic System Oil Level - Check" for the proper procedure for checking the hydraulic oil level.

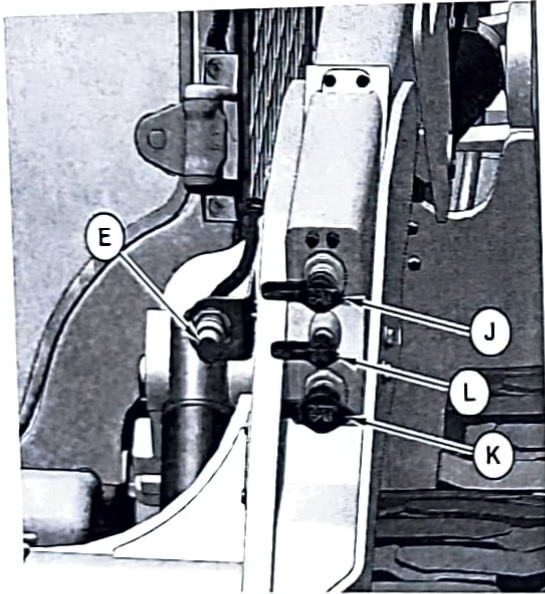

Illustration 290

g06355600

For all High Flow work tools, refer to Operation and Maintenance Manual, "Joystick and Auxiliary Hydraulic Controls". Connect the wiring harness to the electrical plug (E).

**Note:** If your High Flow work tool does not have a wiring harness, a Jumper Plug should be installed on the electrical plug (E) for the work tool control. Without this Jumper Plug, the machine will not provide High Flow to the work tool. Consult your Cat for the correct part number for your machine.

## Simple Hydromechanical Work Tools

Work tools in the following table are approved by Cat. Refer to Operation and Maintenance Manual, "Operator Controls, Joystick Controls, and Operator Controls, Auxiliary Hydraulic Controls" for the location and operation of the joystick controls that are referenced in the table.

Read the manual and understand the instructions and warnings in the Operation and Maintenance Manual for these work tools. Consult your Cat dealer for replacement manuals. Proper care is your responsibility.

Table 24

Operation of Cat Simple Hydromechanical Work Tools

Work Tool								Actions
	Aux5 C2	Aux6 C1	Aux1 A1	Aux2 A2	Aux3 C-	Aux4 C+	Aux7	
Multipurpose Bucket			X					The bucket clam closes.
				X				The bucket clam opens.
All Grapple tools			X					The grapple closes.
				X				The grapple opens.
Angle Blade				X				The blade angles to the left.
			X					The blade angles to the right.
Dozer Blade				X				The blade angles to the left.
			X					The blade angles to the right.
	X			X				The blade tilts down to the left.
	X		X					The blade tilts down to the right.
		X		X				The blade tilts down to the left and the blade angles to the left.
		X	X					The blade tilts down to the right and the blade angles to the right.

Proper operation of the work tool is your responsibility. Do not use the work tool improperly.

Please follow the instructions that are listed below to use the grapple tools safely.

- Do not pry with one rake tine. Use multiple rake tines to loosen material.
- Remove the work tool from the machine before you lift the host machine. Refer to Operation and Maintenance Manual, "Lifting and Tying Down the Machine" for details.
- Do not place the weight of the host machine on the grapples in the open position.

### Complex Hydromechanical Work Tools

Note: For the functionality of Cat Complex Work Tools, please read the Operation and Maintenance Manual for the work tool.

Consult your Cat dealer for replacement manuals. Please read all the safety messages and understand all the safety messages for each work tool.

07167346

## Rubber Belt Track Operation (If Equipped)

SMCS Code: 4198

The rubber part of the track assembly can easily be damaged during operation. Operate the machine with the rubber belt only if damage to the rubber belt is shallow and the damage is not harmful. However, any harmful damage to the rubber can cause the following serious problems to the entire track assembly:

- Early wear of iron core.
- Early wear of track grousers.
- Fracture of iron core.
- Fracture of track grousers.



- Cuts of steel cords
- Rubber flaking off
- Disengagement of sprocket

Such a failed track assembly needs to be replaced as a unit. To minimize the replacement of the track, observe the following items. To maximize the performance of the track, observe the following items:

- Avoid operation under salty conditions.
- Avoid combined operation of travel and turning with excessive load on rough terrain.
- Avoid operation at rocky or demolition sites.
- Use the rubber belt tracks at temperatures within  $-15\text{ }^{\circ}\text{C}$  ( $5\text{ }^{\circ}\text{F}$ ) to  $38\text{ }^{\circ}\text{C}$  ( $100.4\text{ }^{\circ}\text{F}$ ). Avoid operation on hot surfaces.
- If the sprockets are badly worn, use a new sprocket for replacement.
- Be sure that the tracks are free of oily materials such as fuel, hydraulic oil, or grease.
- Avoid going over sharp obstacles. Decreased life of the track, fracture of the track grousers and cut steel cords can occur.
- Track tension must be correctly maintained and checked regularly.
- Disengagement of the track could occur if the track gets clear of the track roller. This condition could occur while the machine travels over an obstacle.

# Parking

i07330974

## Stopping the Engine

SMCS Code: 1000; 7000

### NOTICE

Stopping the engine immediately after it has been working under load can result in overheating and accelerated wear of the engine components. Refer to the following procedure to allow the engine to cool, and to prevent excessive temperatures in the turbo-charger housing (if equipped) which could cause oil coking problems.

1. Operate the engine for 5 minutes at low idle with no load.

**Note:** This operation allows hot areas in the engine to cool gradually. This operation will extend the engine life.

2. Move the joysticks to the NEUTRAL position.
3. Turn the engine start switch key to the OFF position.

i07868120

## Stopping the Engine if an Electrical Malfunction Occurs

SMCS Code: 1000; 7000

### Inside Cab

### NOTICE

Perform a walk around inspection after actuation of a shutdown device.

Take necessary corrective action to resolve the cause of the shutdown.

Ensure that no additional damage has been done or could occur before returning to operation.

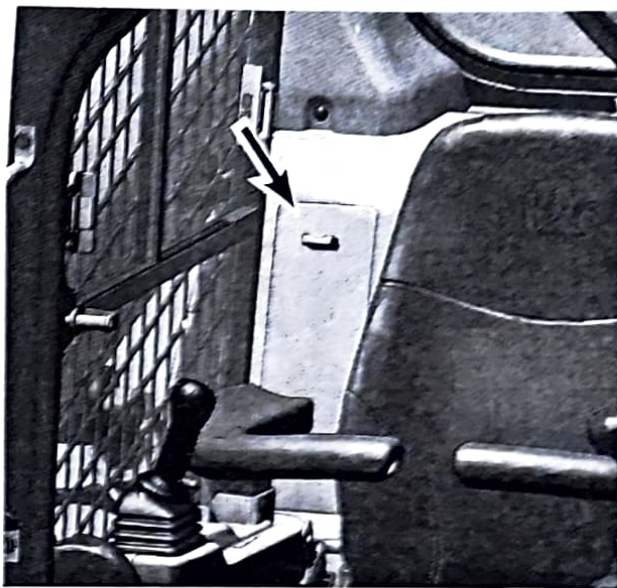

Illustration 291

g06355637

The fuse panel is located behind the seat on the right side.

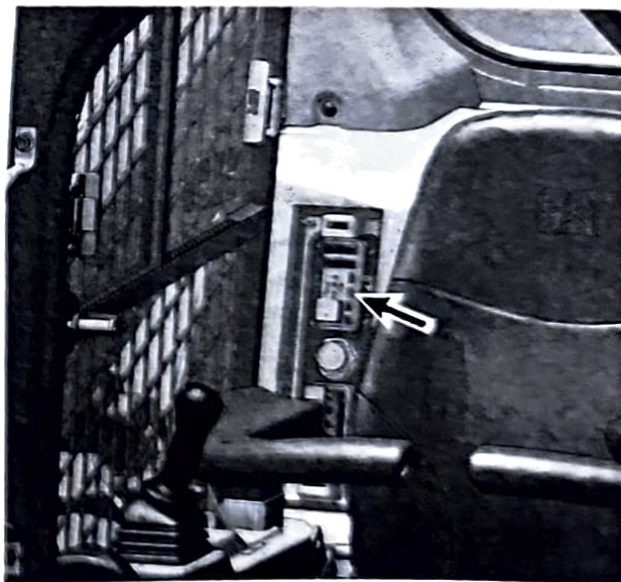

Illustration 292

g063556136

Remove the cover to access the fuse panel.



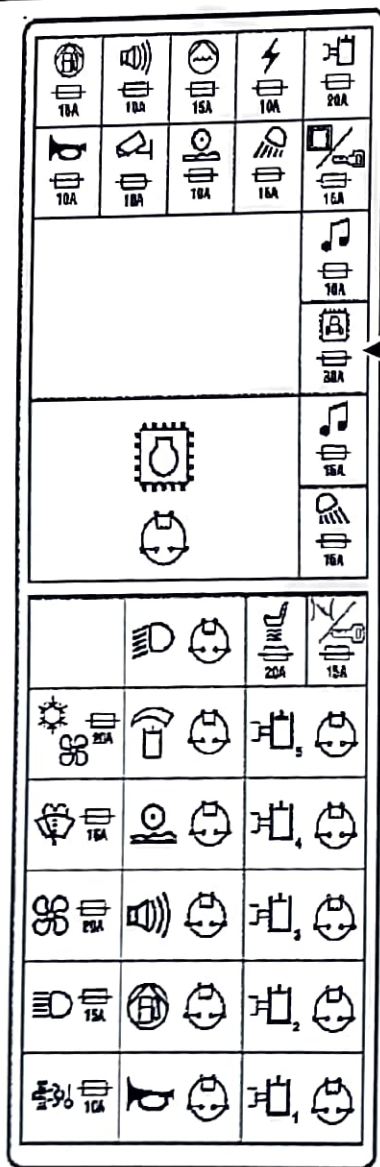

Illustration 293

g06298757

Engine ECM fuse

Remove the Engine ECM fuse to stop the engine.

**Note:** Do not operate the machine until the malfunction has been corrected.

## Equipment Lowering with Engine Stopped

SMCS Code: 6700; 7000

### WARNING

Personal injury or death can result from a work tool falling.

Keep personnel away from the front of the machine when lowering the work tool.

Before lowering any equipment with the engine stopped, clear the area around the equipment of all personnel. The procedure will vary with the type of equipment that is lowered. Keep in mind that most systems use a high-pressure fluid or air to raise or lower the equipment. The procedure will cause high-pressure air, hydraulic fluid, or some other media to be released to lower the equipment. Wear appropriate personal protective equipment and follow the established procedure in the Operation and Maintenance Manual, "Equipment Lowering with Engine Stopped" in the Operation Section of the manual.

### Lowering the Equipment with the Accumulator Charged

If electrical power is available and the accumulator is charged, the loader arms can be lowered from the operator station with the work tool control.

1. Fasten the seat belt. Lower the armrests.
2. If machine security is installed, key in a valid Master Code or Operator Code. See "User Management, Master Code, and Operator Code".
3. Move the engine start switch to the ON position. Press the parking brake switch and release the parking brake switch.

**Note:** The parking brake indicator will remain illuminated since the engine is not running. When the indicator for the work tool is no longer illuminated, the pressure can be released.

4. Slowly move the work tool control to the LOWER position to slowly lower the loader arms.

If the loader arms do not lower, the accumulator is not charged. It is possible to recharge the accumulator by cranking the engine for 15 seconds. Repeat step 3 and 4.

If there is no electrical power the loader arms must be lowered by using the procedure that is explained next.

## Alternate Lowering the Equipment

### WARNING

Personal injury can result from oil under high pressure.

DO NOT allow high pressure oil to contact skin.

Wear appropriate protective equipment while working with high pressure oil systems.

The loader arms must be lowered manually if the accumulator is not charged or if there is no electrical power.

Do not go under the raised lift arm without the brace for the loader lift arm in the LOCKED position.

**Note:** Make sure that there are no people near the front or sides of the machine.

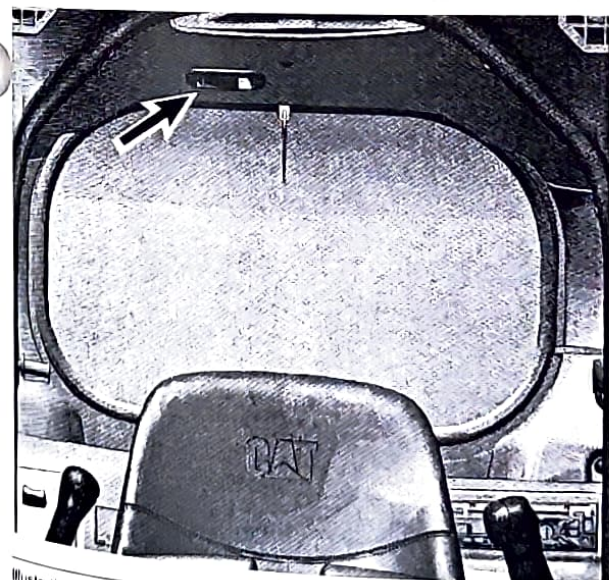

Illustration 294  
Roof-mounted Finger Latch

g06411886

The bypass valve (Dead Engine Lower) is located overhead on the underside of the cab roof.

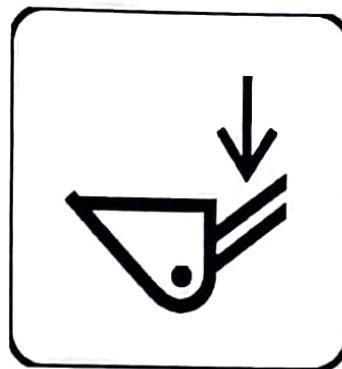

Illustration 295

g01332374

Film molded into the finger latch.

### Actuation

1. Pull down on the finger latch. Release the finger latch to stop the loader arms, if necessary.
2. Allow the loader arms to lower until the work tool is on the ground.
3. Release the finger latch.
4. Make the necessary repair before you operate the machine.

i07331337

## Leaving the Machine

SMCS Code: 7000

Refer to Operation and Maintenance Manual, "Parking" for details about stopping the engine and lowering the equipment.

i07735116

## Machine Storage and Specified Storage Period

SMCS Code: 7000

### Machine Storage

The Safety Section of this Operation and Maintenance Manual contains storage information for fuels, lubricants, and ether (if equipped).

The Operation Section of this Operation and Maintenance Manual contains information for short-term storage of this machine, including engine shutdown, parking, and instructions for leaving the machine.



For detailed steps on long-term storage refer to Special Instruction, SEHS9031, "Storage Procedure for Caterpillar Products".

## **Specified Storage Period**

The specified storage period of this machine is 1 year.

After the specified storage period has expired, consult your Cat dealer for inspect, repair, rebuild, install remanufactured, or install new components, and disposal options, and to establish a new specified storage period.

If a decision is made to remove the machine from service, refer to Decommissioning and Disposal for further information.

# Transportation Information

i07331340

## Shipping the Machine

SMCS Code: 7000

Investigate the travel route for overpass clearances. Make sure that there will be adequate clearance.

Before you load the machine and before you unload the machine remove ice, snow, or other slippery material from the loading dock and from the trailering surface. Removal of ice, snow, or other slippery material will help prevent the slipping of the machine as you load the machine. Removing ice, snow, or other slippery material will help prevent the machine from moving in transit.

### NOTICE

Obey all state and local laws governing the weight, width and length of a load.

Make sure the cooling system has proper antifreeze if moving machine to a colder climate.

Observe all regulations governing wide loads.

Do not use a fork lift to lift the machine. Using a fork lift to move your machine can result in property damage.

Choose the flattest ground when you load the machine or when you unload the machine.

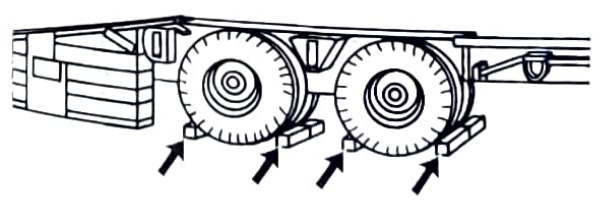

Illustration 296

g00040011

1. Before you load the machine, chock the trailer wheels or the rail car wheels. Before you unload the machine, chock the trailer wheels or the rail car wheels.

2. When you use loading ramps, make sure that the loading ramps have adequate length, adequate width, and adequate strength. In addition, make sure that the surface of the loading ramps is clean. This will help prevent the machine from sliding in all types of weather conditions. This will allow the machine to move on the ramps smoothly.
3. Maintain the slope of the loading ramps within 15 degrees of the ground.
4. Minimize any step between the base of the loading ramps and the ground.
5. Clean the tracks or tires on the machine to prevent any slippage.

## Loading the Machine

1. Position the machine so that the heaviest end of the machine is going up the ramps first.
2. Use caution when you travel over the areas around the loading ramp joints. Maintain the balance point of the machine. Keep the work tool low.
3. After you load the machine onto the trailer be sure that the machine is properly positioned on the trailer bed.
4. Lower the work tool to the floor of the transport vehicle.
5. Turn the engine start switch key to the OFF position to stop the engine.
6. Turn the engine start switch key to the ON position. Push the parking brake switch.
7. Move all joystick controls while you are pressing several times on each side of the auxiliary hydraulic control (if equipped) to relieve hydraulic pressure.
8. Move all hydraulic controls to the NEUTRAL position.
9. Turn the engine start switch key to the OFF position. Remove the engine start switch key.
10. Move the armrests to the RAISED position. Unfasten the seat belt.
11. Attach any vandalism protection.
12. Refer to the Operation and Maintenance Manual, "Lifting and Tying Down the Machine" for information on tying down the machine.