

## Operation Section Before Operation

### Mounting and Dismounting

SMCS Code: 6700; 7000

i07317232



Illustration 68

g06278943

#### Typical example

Mount the machine and dismount the machine only at locations that have steps and/or handholds. Before you mount the machine, clean the steps and the handholds. Inspect the steps and handholds. Make all necessary repairs.

Face the machine whenever you get on the machine and whenever you get off the machine.

Maintain a three-point contact with the steps and with the handholds.

**Note:** Three-point contact can be two feet and one hand. Three-point contact can also be one foot and two hands.

Do not mount a moving machine. Do not dismount a moving machine. Never jump off the machine. Do not carry tools or supplies when you try to mount the machine or when you try to dismount the machine. Use a hand line to pull equipment onto the platform. Do not use any controls as handholds when you enter the operator compartment or when you exit the operator compartment.

## Machine Access System Specifications

The machine access system has been designed to meet the intent of the technical requirements in "ISO 2867 Earth-moving Machinery – Access Systems". The access system provides for operator access to the operator station and to conduct the maintenance procedures described in Maintenance section.

### Alternate Exit

Machines that are equipped with cabs have alternate exits. For additional information, see Operation and Maintenance Manual, "Alternate Exit".

i07525343

## Daily Inspection

SMCS Code: 1000; 6319; 6700; 7000

### **⚠ WARNING**

Hot oil and hot components can cause personal injury. Do not allow hot oil or hot components to contact skin.

At operating temperature, the engine coolant is hot and under pressure.

Steam can cause personal injury.

Check the coolant level only after the engine has been stopped and the cooling system pressure cap is cool enough to touch with your bare hand.

Remove the cooling system pressure cap slowly to relieve pressure.

Cooling system conditioner contains alkali. Avoid contact with the skin and eyes to prevent personal injury.

### NOTICE

Accumulated grease and oil on a machine is a fire hazard. Remove this debris with steam cleaning or high pressure water, at least every 1000 hours or each time any significant quantity of oil is spilled on a machine.

For maximum service life of the machine, perform a thorough walk-around inspection before you mount the machine and before you start the engine.

## First 100 Hours

Daily, perform the procedures that are applicable to your machine.

- Operation and Maintenance Manual, "Boom and Stick Linkage - Lubricate"

- Operation and Maintenance Manual, "Bucket Linkage - Lubricate"

## Severe Applications

Daily, perform the procedures that are applicable to your machine:

- Operation and Maintenance Manual, "Boom and Stick Linkage - Lubricate"
- Operation and Maintenance Manual, "Bucket Linkage - Lubricate"

## Daily Basis

Daily, perform the procedures that are applicable to your machine:

- Operation and Maintenance Manual, "Fuel Tank Water and Sediment - Drain"
- Operation and Maintenance Manual, "Hydraulic System Oil Level - Check"
- Operation and Maintenance Manual, "Indicators and Gauges - Test"
- Operation and Maintenance Manual, "Seat Belt - Inspect"
- Operation and Maintenance Manual, "Track Adjustment - Inspect"
- Operation and Maintenance Manual, "Travel Alarm - Test"
- Operation and Maintenance Manual, "Undercarriage - Check"

Refer to Operation and Maintenance Manual, "Maintenance Interval Schedule" for all maintenance recommendations

**Note:** Watch closely for leaks. If you observe a leak, find the source of the leak and correct the leak. If you suspect a leak or you observe a leak, check the fluid levels more frequently

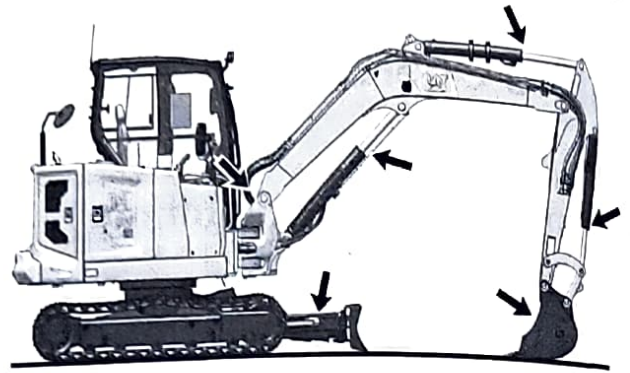

Illustration 69

g06349453

Inspect the attachment control linkage, attachment cylinders, and attachment for damage or excessive wear. Make any necessary repairs.

Inspect the lights for broken bulbs and for broken lenses. Replace any broken bulbs and any broken lenses.

Inspect the engine compartment for any trash buildup. Remove any trash buildup from the engine compartment.

Inspect the cooling system for any leaks, for faulty hoses and for any trash buildup. Correct any leaks. Remove any trash from the radiator.

Inspect all the belts for the engine attachments. Replace any belts that are worn, frayed, or broken.

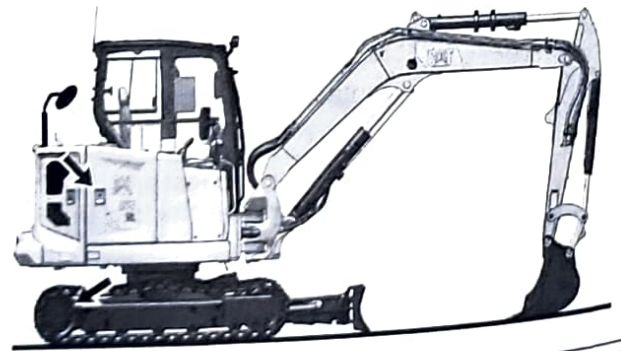

Illustration 70

g06349455

Inspect the hydraulic system for leaks. Inspect the tank, cylinder rod seals, hoses, tubes, plugs, connections, and fittings. Correct any leaks in the hydraulic system.

Inspect the tubes and hoses along the boom and stick for wear and leaks. Replace any hoses or tubes that are worn or leak.

Inspect the differential and the final drives for leaks. Make any necessary repairs.

Inspect the swing drive for leaks.

Make sure that all covers and guards are securely attached. Inspect the covers and the guards for damage.

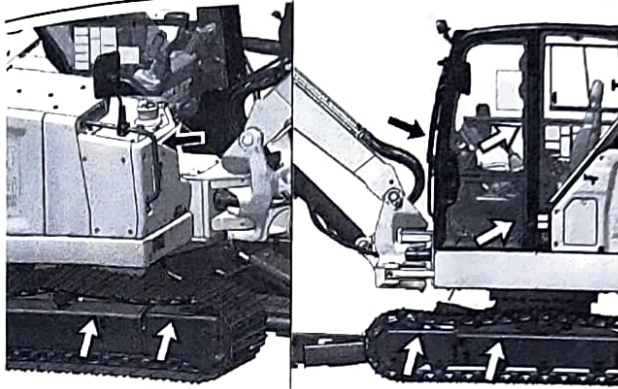

Illustration 71

g06349475

Inspect the steps, the walkways, and the handholds.  
Clean the steps, the walkways, and the handholds.  
Make any necessary repairs.

Inspect the operator compartment for trash buildup.  
Check for trash buildup under the floorplate and on  
the crankcase guard. Keep these areas clean.

Adjust the mirrors to achieve the best visibility.



## Machine Operation

i07291771

### Alternate Exit

SMCS Code: 7310



Illustration 72

g06276524



**Alternate Exit** – The rear window serves as an alternate exit.



**Break Glass** – Perform the following procedure to exit through the rear window. A hammer is mounted on the rear of the cab. Strike the rear window with the hammer to break the glass. Climb through the opening of the rear window to exit the cab.

**Note:** Do not use the alternate exit except in an emergency situation.

## Seat

SMCS Code: 5258-025; 7312-025; 7324; 7327

i08197772

### Standard Seat

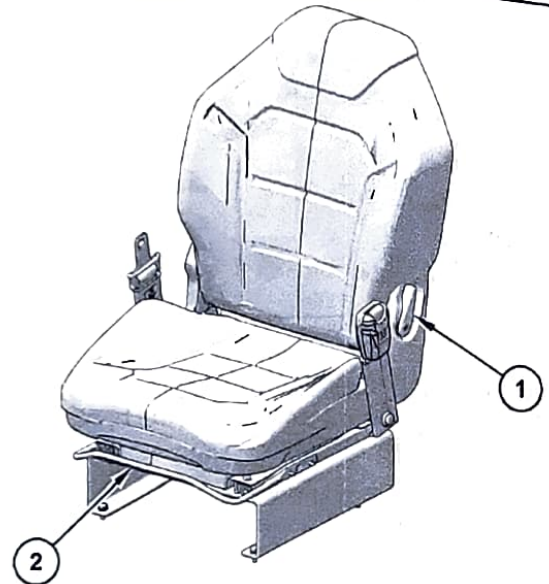

Illustration 73

g06285915

- (1) Recline Lever  
(2) Seat Fore and Aft Lever



Lift up on fore and aft lever (2) to release the seat from the locked position. Adjust the seat forward or rearward to the desired position and then release the lever to lock the seat.

### Comfort Level Seat (If Equipped)



Illustration 74

g06276785

- (1) Recline Lever
- (2) Seat Fore and Aft Lever

Use lever (1) to change the angle of the backrest.



Illustration 75

g06276793

- (1) Recline Lever
- (2) Weight Adjustment Lever (or knob)
- (3) Seat Fore and Aft Lever

Use lever (1) to change the angle of the backrest.

To adjust for your weight, turn lever or knob (2) on the front of the seat.

Lift on fore and aft lever (3) to release the seat from the locked position. Adjust the seat forward or rearward to the desired position and then release the lever to lock the seat.

## Deluxe Level Seat (If Equipped)



Illustration 76

g06276726

- (1) Headrest
- (2) Heat Switch
- (3) Lumbar Adjustment Knob
- (4) Recline Lever
- (5) Suspension Adjustment
- (6) Seat Fore and Aft Lever

The operator can adjust the height of headrest (1). To adjust the headrest, hold the headrest with both hands. Move the headrest up and down. Release the headrest when the desired position is attained. The headrest will remain in the desired position.

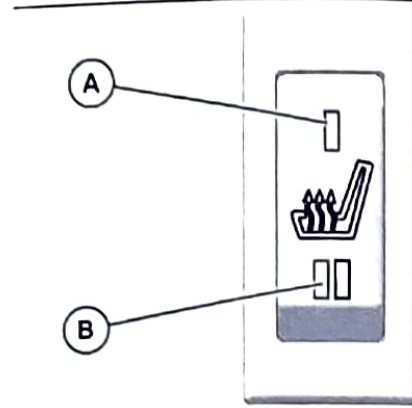

Illustration 77

g08251600

- (A) Low heat
- (B) High heat

Seat heater switch (2) is a three position switch. The middle position of the switch is off. Press the top position of the switch for low heat. Press the bottom of the switch for high heat.

### **⚠ WARNING**

Heat-induced burns can occur when some people use a seat heater. Do not use the seat heater if you have a reduced ability to sense temperature changes, a reduced ability to feel pain, or have sensitive skin.

The lumbar support is located in the back of the seat. Turn knob (3) counterclockwise to increase the force of the lumbar support. To decrease the lumbar support, continue to turn the knob counterclockwise.

Pull up lever (4) to change the angle of the backrest. With the backrest in the desired position. Release the lever.

Use seat height suspension adjustment lever (5) to adjust the seat for the operator's height and weight.

Lift on fore and aft lever (6) to release the seat from the locked position. Adjust the seat forward or rearward to the desired position and then release the lever to lock the seat.

i07092308

## Seat Belt

**SMCS Code:** 7327

**Note:** This machine was equipped with a seat belt when the machine was shipped from Caterpillar. At the time of installation, the seat belt and the instructions for installation of the seat belt meet the SAE J386 and ISO 6683 standards. Consult your Cat dealer for all replacement parts.



Always check the condition of the seat belt and the condition of the mounting hardware before you operate the machine.

## Seat Belt Adjustment for Retractable Seat Belts

### Fastening The Seat Belt

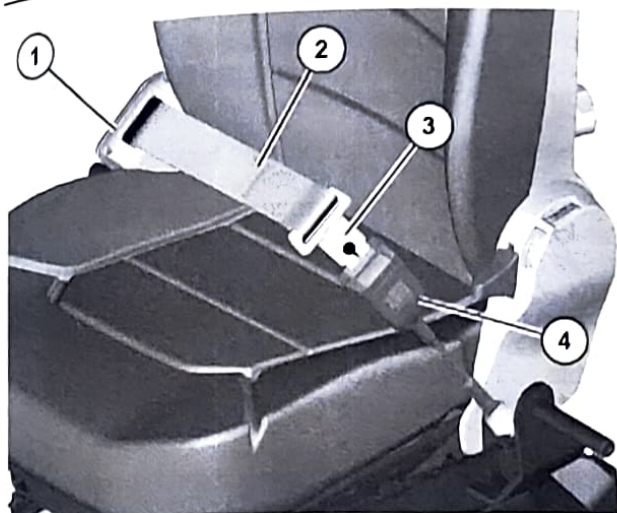

Illustration 78

g06223891

Pull seat belt (2) out of retractor (1) in a continuous motion.

Fasten seat belt catch (3) into buckle (4). Make sure that the seat belt is placed low across the lap of the operator.

The retractor will adjust the belt length and the retractor will lock in place. The comfort ride sleeve will allow the operator to have limited movement.

### Releasing The Seat Belt



Illustration 79

g06223894

Push the release button on the buckle to release the seat belt. The seat belt will automatically retract into the retractor.

### Extension of the Seat Belt

#### **WARNING**

When using retractable seat belts, do not use seat belt extensions, or personal injury or death can result.

The retractor system may or may not lock up depending on the length of the extension and the size of the person. If the retractor does not lock up, the seat belt will not retain the person.

Longer, non-retractable seat belts and extensions for the non-retractable seat belts are available.

Caterpillar requires only non-retractable seat belts to be used with a seat belt extension.



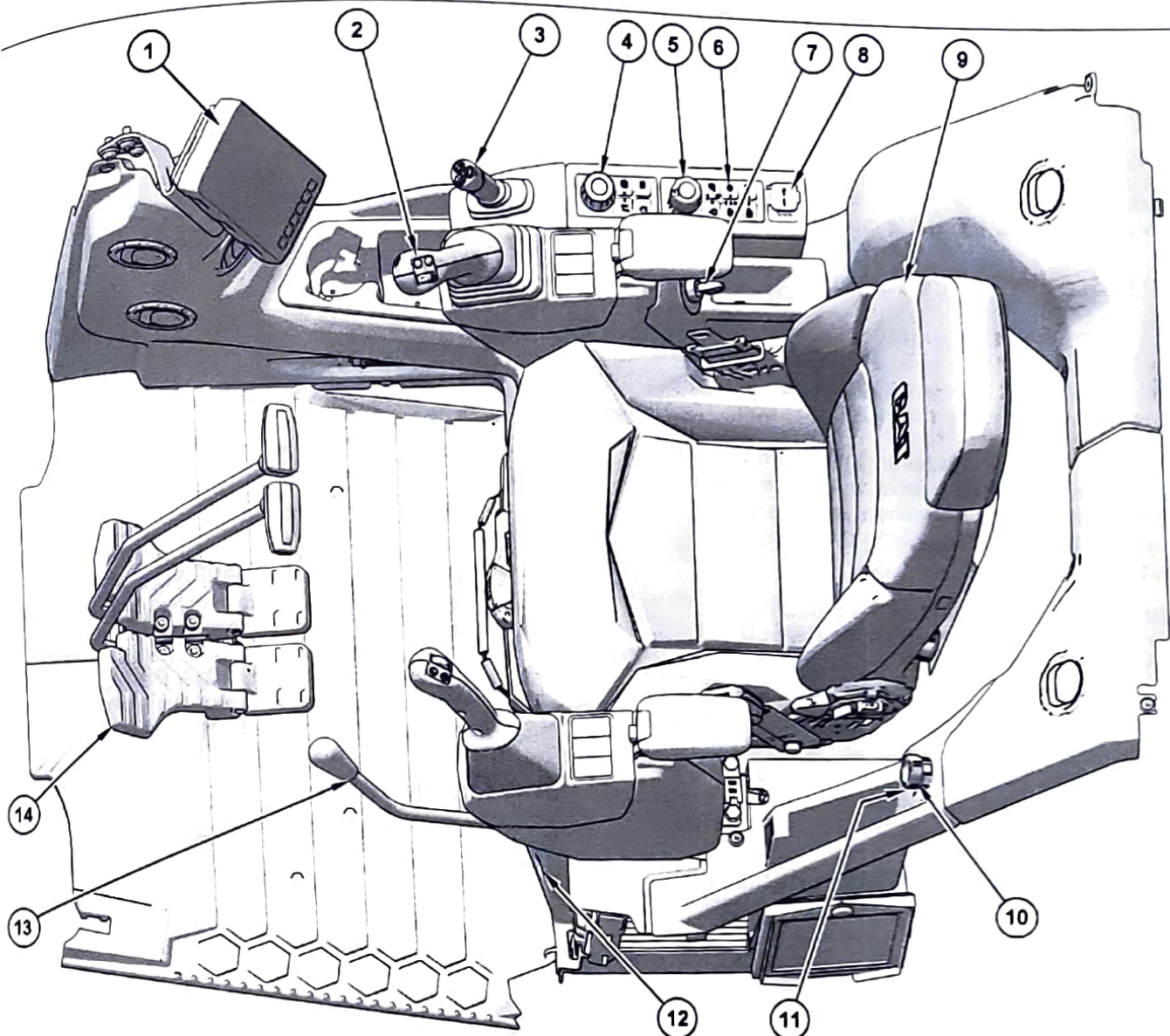

Illustration 84

g06349477

- (1) Monitoring System
- (2) Joystick Controls
- (3) Dozer Blade Lever (if equipped)
- (4) Jog Dial
- (5) Engine Speed Dial

- (6) Right Side Switch Panel
- (7) Engine Start Switch
- (8) USB Port (if equipped)
- (9) Operator Seat
- (10) Diagnostic Port

- (11) Power Outlet (12V)
- (12) Monitor wake-up button (if equipped)
- (13) Hydraulic Lockout Control
- (14) Travel Lever Controls (if equipped)

## Monitoring System (1)

The machine has a composite monitoring system including service hours, joystick pattern change, alert indicators, radio (if equipped), air conditioning system (if equipped), and so forth.

Refer to Operation and Maintenance Manual, "Monitoring System" for more information.

## Joystick Controls (2)

The joystick controls are used to control the functions of the work tools. For more information on the individual functions of the joysticks, refer to Operation and Maintenance Manual, "Joystick Controls".

### Blade Lever (3) (If Equipped)



**Float** – Push the lever fully forward. The blade will lower to the ground. The blade will float with the contour of the ground. The lever will return to the HOLD position.



**Lower** – Push lever (3) forward to lower the blade. The lever will return to the HOLD position when you release the lever. The blade will remain in the selected position.

**Hold** – Lever (3) will return to the HOLD position when the lever is released from the RAISED or LOWERED position.



**Raise** – Pull lever (3) backward to raise the blade. The lever will return to the HOLD position when you release the lever. The blade will remain in the selected position.

### Travel Speed Control (3A) (If Equipped)

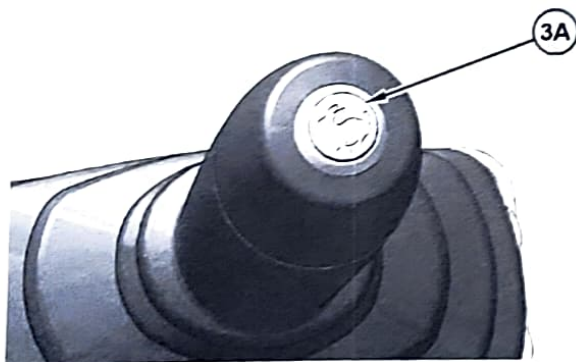

Illustration 85

g06277194

Push high-speed travel switch is on the blade control lever. Use the switch to change the travel speed.

Move the switch to the high-speed position to make the machine travel in high speed. The rabbit travel speed icon will illuminate on the monitor when the machine is in the high-speed mode.

Push the switch again to return to low speed.

Always travel at slow speeds on slopes and rough ground.

### Angle Blade Control (If Equipped)

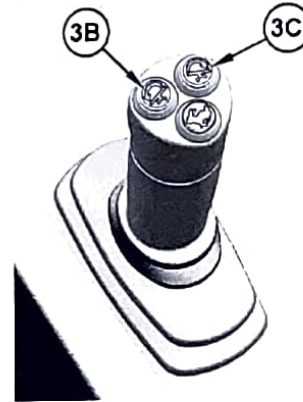

Illustration 86

g06349482



**Angle Blade Left (3B)** – Press the button that is on top of the control lever to angle the blade to the left.



**Angle Blade Right (3C)** – Press the button that is on top of the control lever to angle the blade to the right.

### Jog Dial (4)

Turn dial (4) to choose the desired item in the monitor and depress the dial to activate the selection.



Refer to Operation and Maintenance Manual, "Monitoring System" for more information.

## Engine Speed Dial (5)

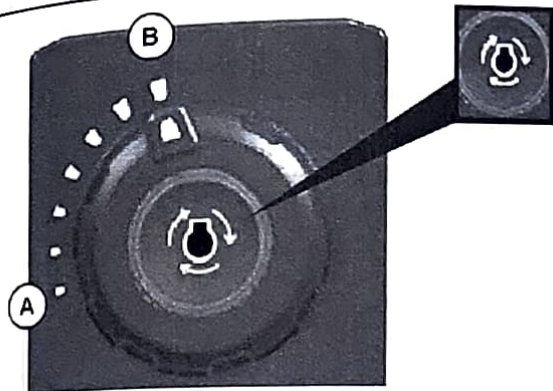

Illustration 87

g06345901

Turn the engine speed dial to control the engine speed (engine rpm). Select the desired position from the seven available positions. Turn the engine speed dial counterclockwise to decrease the engine speed (engine rpm). Turn the engine speed dial clockwise to increase the engine speed (engine rpm).

**Low Engine Idle (A)** – The engine operates in the low rpm range.

**High Engine Idle (B)** – The engine operates in the high rpm range.

Pressing the center of the engine speed dial can change the engine operation mode from "Power On Demand" mode to "Standard" mode. A green illuminator on the center of the throttle dial indicates if the "Power On Demand" mode is ON.

In addition to the green illuminator on the dial, a "SMART" Mode indicator, which is the indicator for "Power On Demand", will illuminate on the monitor. When the machine is in "Standard" Mode, the "Power On Demand" Mode indicator will not be illuminated on the monitor.

**Note:** Some machines may prohibit toggling of the "Power On Demand".

## Right Switch Panel (6)

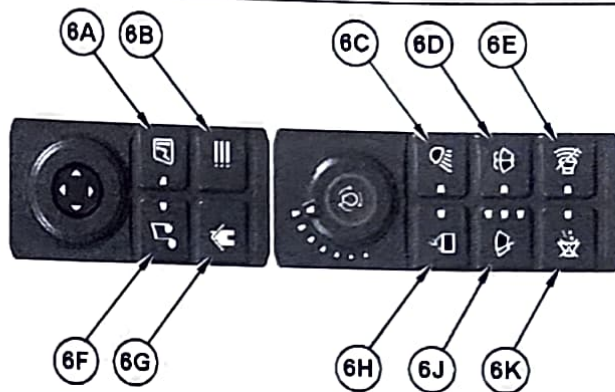

Illustration 88

g06285454

### HVAC Control Shortcut (6A)

Pressing this button will navigate the monitor to display the relevant screen for HVAC controls.

The air conditioner provides comfort for the operator that is working under various temperature conditions. When the LED is lit, the HVAC is ON.

### Display Menu Shortcut (6B)

Pressing this button to navigate to the display menu in the monitor.

### Work Light Switch (6C)



**Lights** – Pressing the work lights button once turns the front work lights ON and illuminates the top LED. Pressing the button again within two seconds also illuminates the rear work lights and the bottom LED. Pressing the button again within two seconds turns OFF the front work lights and only illuminates the bottom LED. Pressing the button again (or waiting more than two seconds after any of the previous presses) turns OFF all work lights and indicator LEDs.

### Window Washer (6D)



**Window Washer** – Push the button to activate the window washer. The LED will illuminate while the button is pressed. Two wiper cycles will be completed after releasing the button.



**NOTICE**

If the wiper does not operate with the switch in the ON position, turn the switch off immediately. Check the cause. If the switch remains on, motor failure can result.

**NOTICE**

If the washer is used continuously for more than 20 seconds or used when no washer solution comes out, motor failure can result.

**Travel Alarm Cancel (6E)**

**Travel Alarm Cancel – LED will illuminate while the travel alarm is canceled. Button must be pressed every time travel command is initiated to mute the travel alarm.**

**Note:** The travel alarm will sound when the travel levers or the travel pedals are activated.

**Radio Control Shortcut (6F)**

Pressing this button will navigate the monitor to display the relevant screen for radio controls.

**Home Screen Shortcut (6G)**

Press the button to return back to the home menu on the monitor.

**Overload Warning Cancel Switch (6H) (If Equipped)**

**Overload Warning Device – If equipped with Overload Warning, this functions as the ON/OFF switch for that feature.**

**When ON, the overload warning system activates and there is an audible alarm and message on the display if the boom pressure exceeds the specified threshold. Press button to cycle overload warning between ON and OFF.**

**ON – When the LED is lit, the overload warning is ON.**

**OFF – When the LED is not lit, the overload warning is OFF.**

**Window Wiper Control (6J)**

**Window Wiper – Pressing the wiper button once turns the wiper ON with a 6 second delay. Pressing the button again changes the delay to 3 seconds. Pressing the button again turns on the wiper continuously. Pressing the button again turns OFF the wiper. If the front window is open, the wipers will not turn ON. If the window is opened while the wiper is ON, it will stop until the window is closed.**

**No LEDs – Wipers are OFF**

**1 LED – 6 second intermittent delay**

**2 LEDs – 3 second intermittent delay**

**3 LEDs – Full ON**

**Radio Mute Switch (6K)**

**Radio Mute Switch – Press the switch to mute the radio. The indicator lamp will turn ON while the radio is muted.**

**Engine Start Switch (7)****NOTICE**

The engine start switch must be in the ON position and the engine must be running in order to maintain electrical functions and hydraulic functions. This procedure must be followed in order to prevent serious machine damage.

**Note:** Always place the hydraulic lockout lever in the RAISED position when you are starting the engine. The engine start switch will not function if the left hydraulic control is in the LOWERED position.

### Key Switch (If Equipped)

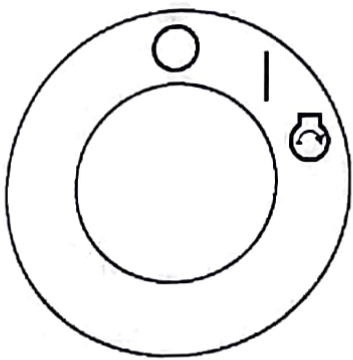

Illustration 89 g06285484

**OFF** – Insert the engine start switch key only while the start switch is in the OFF position. Remove the engine start switch key only while the engine start switch is in the OFF position. Turn the engine start switch to the OFF position before you attempt to restart the engine. Turn the engine start switch to the OFF position to stop the engine.

**ON** – To activate the electrical circuits in the cab, turn the key clockwise to the ON position.

**START** – To start the tractor engine, turn the key clockwise to the START position. After the engine starts, release the key. The key will return to the ON position.

**Note:** If the engine fails to start, return the engine start switch key to the OFF position. Return the key to the start position before you attempt to start the engine again.

See this Operation and Maintenance Manual, "Engine Starting" for additional information.

### Push to Start (If Equipped)

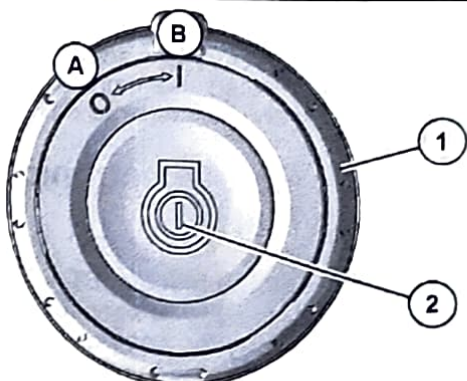

Illustration 90 g06180554

- (A) Off
- (B) On
- (1) Engine start ring
- (2) Start button

**OFF** – Turn the engine start ring (1) to the OFF position (A) to stop the engine.

**ON** – To activate the electrical circuits in the cab and enable engine starting, turn the engine start ring (1) clockwise to the ON position (B).

**START** – To start the engine, enter the code on the monitor (only required if machine security is enabled). Press start button (2). After the engine starts, release the button.

### USB Port (8) (If Equipped)

The USB port allows the operator to have extra media equipment connected to the machine.



Note: For charging purposes only.

## Operators Seat (9)

The operators seat has various adjustments to meet a wide range of operators. For more information, refer to Operation and Maintenance Manual, "Seat".

## Diagnostic Port - Electronic Technician (10)



**Electronic Technician (ET)** – This service port allows service personnel to connect a laptop computer to the machine electronics using the Cat® Electronic Technician (Cat ET) Service Tool. This connection will allow service personnel to interrogate the machine systems and engine systems.

## Power Outlet (11)

A 12V power receptacle is located left of the seat below the diagnostic connector. The power receptacle can be used for powering automotive electrical equipment or accessories. Raise the cap to use.

## Monitor Wake-up Button (12) (If Equipped)

This feature will function when the key is in the OFF position and the battery disconnect switch is in the ON position.

Pressing monitor wake-up button (12) will display the service hours of the machine and actual fuel level on the monitor display for two minutes.

**Note:** This feature can also be activated by pressing any button on the performance monitor (if equipped).

## Hydraulic Lockout Control (13)

### WARNING

Deactivation of the hydraulic controls does not prevent the blade, boom swing, or auxiliary circuit functions from moving under gravity or other external forces. Gravity or other external forces can move the blade, boom swing, or auxiliary circuit functions suddenly if a hydraulic control lever is moved.

**Personal injury or death may occur from sudden machine movement.**



**Locked** – Place the hydraulic lockout control in the **RAISED** position to deactivate the hydraulic controls.

Make sure that the hydraulic lockout control is in the **RAISED** position before you exit the machine.

**Note:** Always put the left hydraulic lockout control in the **RAISED** position before starting the engine. The engine start switch will not function if the left hydraulic control is in the **LOWERED** position.



**Unlocked** – Place the hydraulic lockout control in the **LOWERED** position. When the hydraulic lockout control is in the **LOWERED** position, the hydraulic controls are operable.

**Note:** The hydraulic controls will only function if the joystick levers are centered when the implements are **UNLOCKED**. If the joystick levers are not centered when the hydraulic controls are switched from **LOCKED** to **UNLOCKED**, the hydraulic circuit associated with the lever out of center will be disabled until the joystick lever is centered.

## Travel Lever Controls (If Equipped) (14)

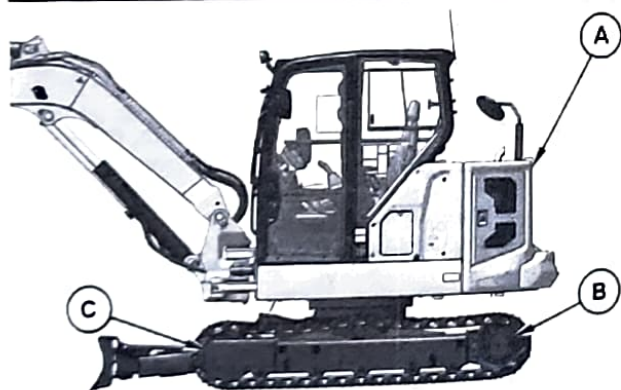

Illustration 91

Position for normal travel

- (A) Rear of machine
- (B) Final drive
- (C) Idler

When you travel, make sure that final drive sprockets (B) are under the rear of the machine.

**Stop** – Release the travel levers/pedals to stop the machine. When you release the travel levers/pedals from any position, the travel levers/pedals will return to the **CENTER** position. The travel brakes will be applied.

Move both of the travel levers or both of the travel pedals equally in the same direction to travel straight.

g06349484



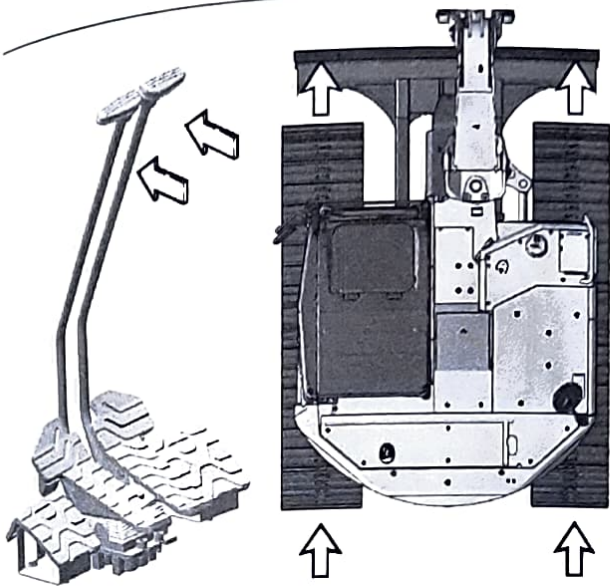

Illustration 92  
FORWARD travel

g06338693

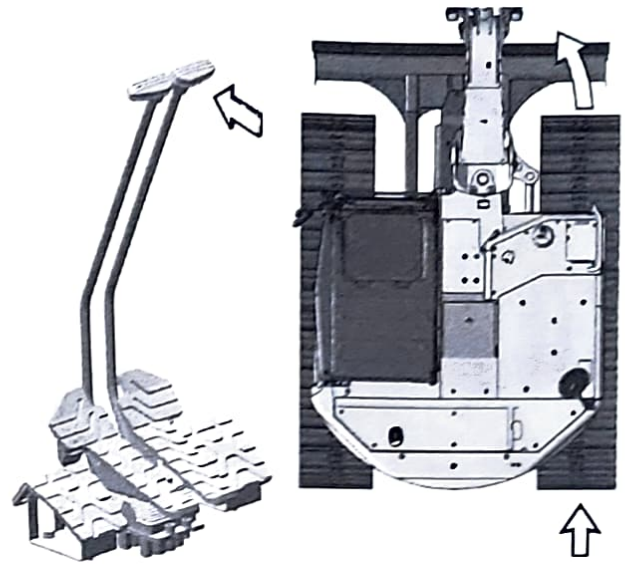

Illustration 94  
Pivot left turn (FORWARD)

g06338702

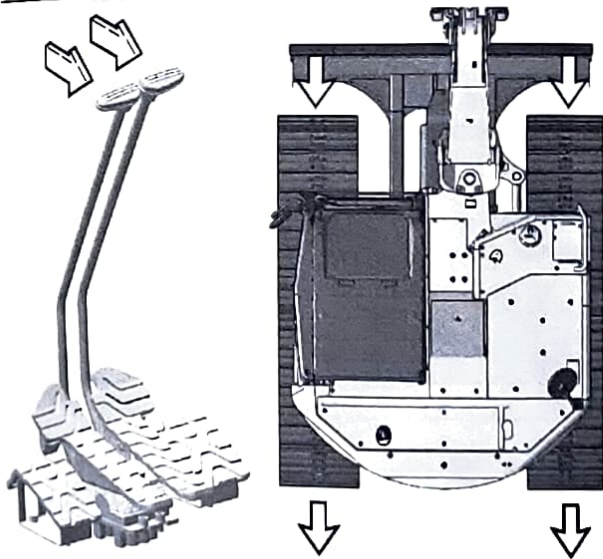

Illustration 93  
REVERSE travel

g06338696

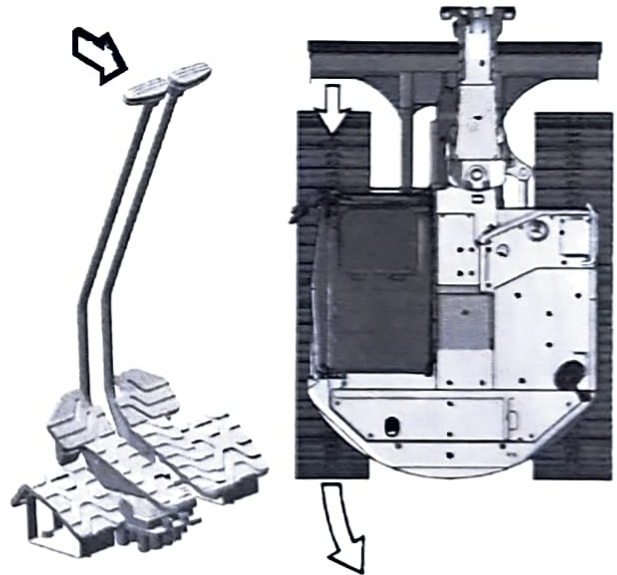

Illustration 95  
Pivot Left Turn (REVERSE)

g06338705

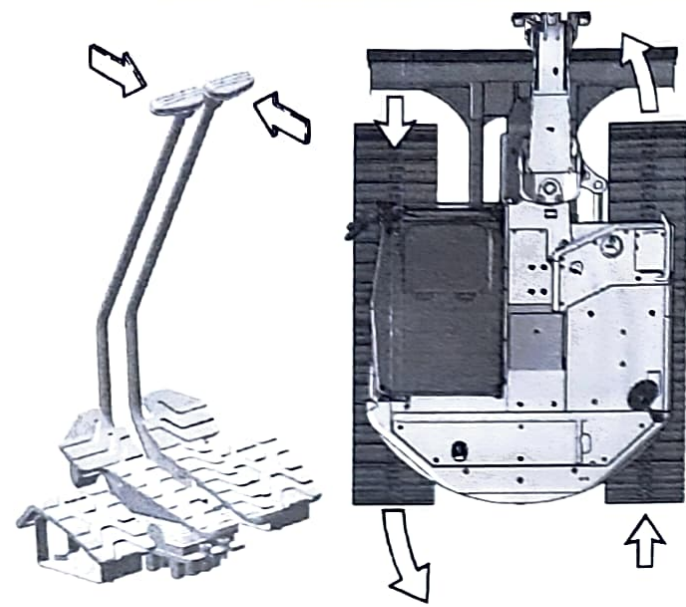

Illustration 96  
Counterrotate turn (LEFT)

g06338709

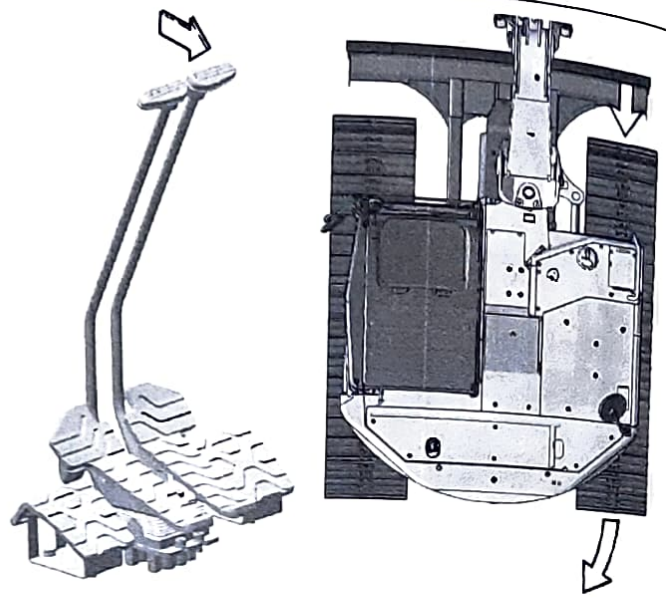

Illustration 98  
Pivot right turn (REVERSE)

g06338716

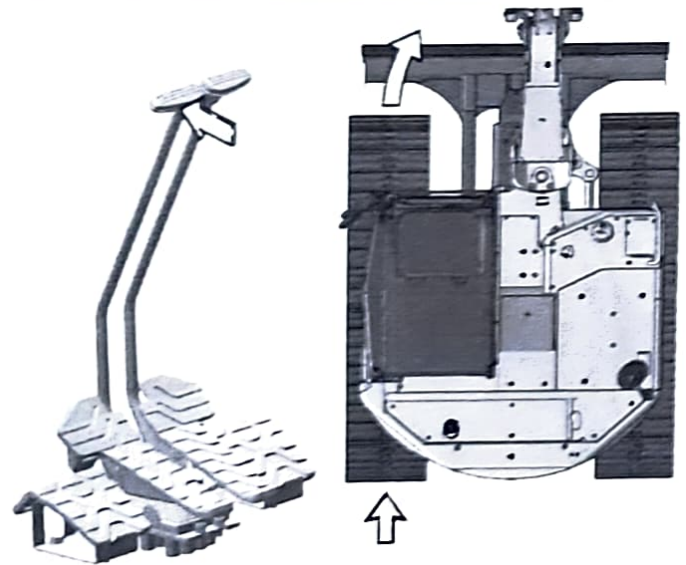

Illustration 97  
Pivot right turn (FORWARD)

g06338713



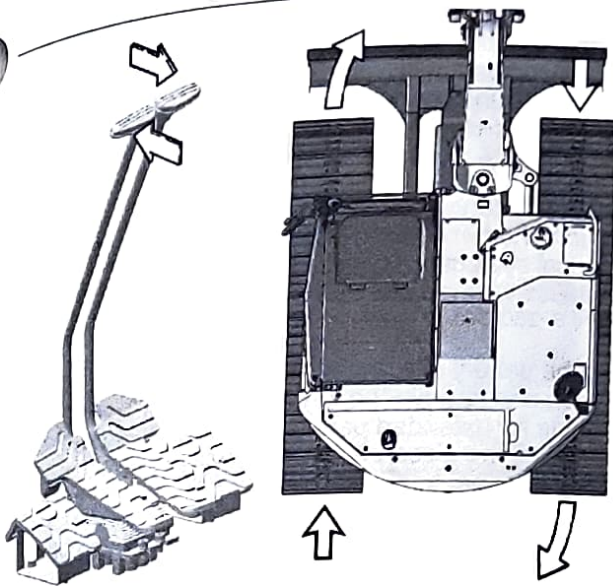

Illustration 99  
Counterrotate turn (RIGHT)

g06338735

### Auxiliary Control Pedal (If Equipped) (15)

The auxiliary control pedal is used to control Aux 1 work tools. For more information on the auxiliary controls, refer to Operation and Maintenance Manual, Work Tool Control.

i08265397

### Cab Dome Light

SMCS Code: 1433

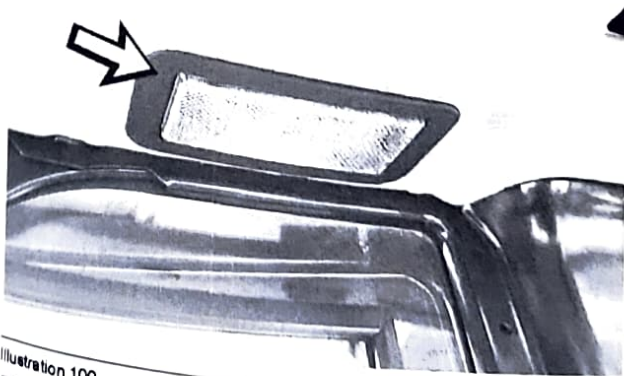

Illustration 100  
Dome light in the COURTESY LIGHT position

g06466796

The cab dome light is located inside the cab above the door.

The lens of the lamp is a three-position switch.

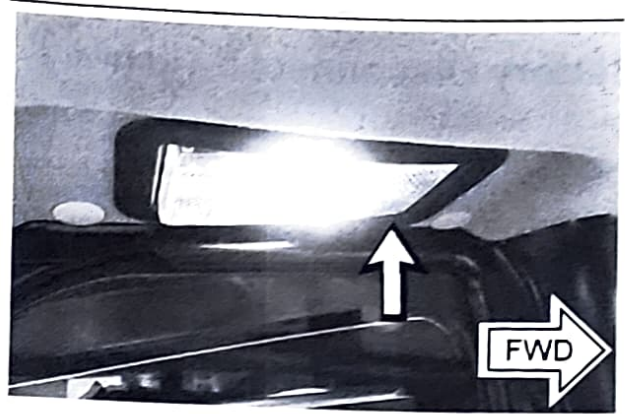

Illustration 101  
Dome light in the ON position

g06466801

When the front of the lamp is pressed upward, the lamp will be in the ON position.

When the rear of the lamp is pressed upward, the lamp will be in the OFF position.

When the lamp is in the middle (horizontal position), the lamp will be in the COURTESY LIGHT position.

The courtesy light allows the machine lighting to stay ON for a configurable (0 to 100 seconds) period of time after turning the key switch OFF.

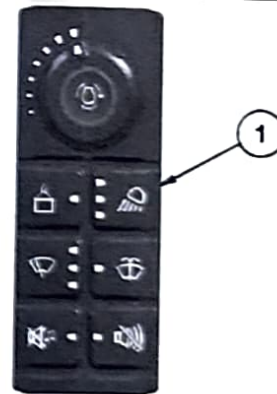

Illustration 102  
Right switch panel

g06466812

**Note:** For the lamp to illuminate in the COURTESY LIGHT position, work light switch (1) must be in an ON position, when the key is switched to OFF.



i08372948

## Battery Disconnect Switch

SMCS Code: 1411-B11



Illustration 103

g06349490

The battery disconnect switch is on the right side of the machine behind the right access door.

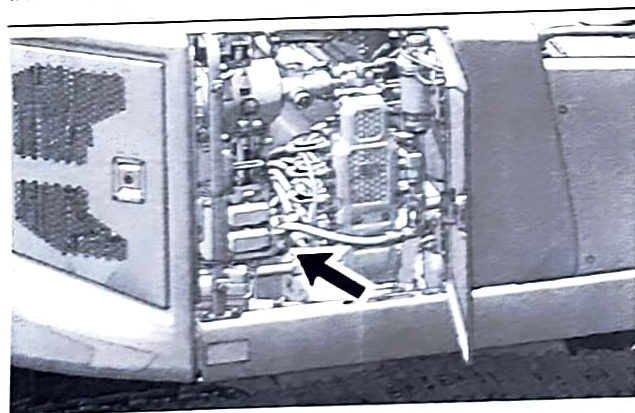

Illustration 104

g06349491

Battery disconnect switch



**Battery Disconnect Switch** – The battery disconnect switch can be used to disconnect the battery from the machines electrical system. The key must be inserted into the battery disconnect switch before the battery disconnect switch can be turned.



**ON** – To activate the electrical system, insert the disconnect switch key and turn the battery disconnect switch clockwise. The battery disconnect switch must be turned to the ON to enable battery power to start the engine.



**OFF** – To deactivate the electrical system, turn the battery disconnect switch counterclockwise to the OFF position.

The battery disconnect switch and the engine start switch perform different functions. The entire electrical system is disabled when you turn the battery disconnect switch to the OFF position. The battery remains connected to the electrical system when you turn the engine start switch to the OFF position.

Turn the battery disconnect switch to the OFF position and remove the key when you service the electrical system or any other machine components. If installed with a cover lock, close the cover and install a padlock.

Turn the battery disconnect switch to the OFF position and remove the key if you do not operate the machine for extended periods of a month or more. Turning off the disconnect switch will prevent the battery from being discharged.

A good practice is to use the disconnect switch after you operate the machine. Turning off the disconnect switch will prevent the battery from being discharged. The following problems can cause battery discharge:

- short circuits
- current draw via some components
- vandalism

**Note:** If the machine is equipped with product link, turning the disconnect switch to OFF will remove power from the product link module and it will not be able to communicate.

i08001446

## Product Link

SMCS Code: 7490; 7606

**Note:** Your machine may be equipped with the Cat<sup>®</sup> Product Link™ system.

The Cat Product Link communication device utilizes cellular and/or satellite technology to communicate equipment information. This information is communicated to Caterpillar, Cat dealers, and Caterpillar customers. The Cat Product Link communication device uses Global Positioning System (GPS) satellite receivers.

The capability of two-way communication between the equipment and a remote user is available with the Cat Product Link communication device. The remote user can be a dealer or a customer.

## Data Broadcasts

Data concerning this machine, the condition of the machine, and the operation of the machine is being transmitted by Cat Product Link to Caterpillar and/or Cat dealers. The data is used to serve the customer better and to improve upon Cat products and services. The information transmitted may include: machine serial number, machine location, and operational data, including but not limited to: fault codes, emissions data, fuel usage, service meter hours, software, and hardware version numbers and installed attachments.

Caterpillar and/or Cat dealers may use this information for various purposes. Refer to the following list for possible uses:

- Providing services to the customer and/or the machine
- Checking or maintaining Cat Product Link equipment
- Monitoring the health of the machine or performance
- Helping maintain the machine and/or improve the efficiency of the machine
- Evaluating or improving Cat products and services
- Complying with legal requirements and valid court orders
- Performing market research
- Offering the customer new products and services

Caterpillar may share some or all the collected information with Caterpillar affiliated companies, dealers, and authorized representatives. Caterpillar will not sell or rent collected information to any other third party and will exercise reasonable efforts to keep the information secure. Caterpillar recognizes and respects customer privacy. For more information, please contact your local Cat dealer.

## Operation in a Blast Site for Product Link Radios

### WARNING

This equipment is equipped with a Cat® Product Link communication device. When electric detonators are being used for blasting operations, radio frequency devices can cause interference with electric detonators for blasting operations which can result in serious injury or death. The Product Link communication device should be deactivated within the distance mandated under all applicable national or local regulatory requirements. In the absence of any regulatory requirements Caterpillar recommends the end user perform their own risk assessment to determine safe operating distance.

Refer to your products Operation and Maintenance Manual Supplement, "Regulatory Compliance Information" for more information.

For information regarding the methods to disable the Cat Product Link communication device, please refer to your specific Cat Product Link manual listed below:

- Operation and Maintenance Manual, SEBU8142, "Product Link - PL121, PL321, PL522, and PL523"
- Operation and Maintenance Manual, SEBU8832, "Product Link PLE702, PLE602, PLE601, PL641, PL631, PL542, PL240, PL241, PL243, PL141, PL131, PL161, PL083 and PL042 Systems"

**Note:** If no radio disable switch is installed and the equipment will be operating near a blast zone, a Product Link radio disable switch may be installed on the equipment. The switch will allow the Cat Product Link communication device to be shut off by the operator from the equipment control panel. For more details and installation procedures, refer to the following:

- Special Instruction, REHS7339, "Installation Procedure for Product Link PLE640 Systems"
- Special Instruction, REHS8850, "Installation Procedure for the Elite Product Link PLE601, PLE641, and PLE631 Systems"
- Special Instruction, SEHS0377, "Installation Procedure for the Product Link PL131, PL141, and PL161 Systems"



- Special Instruction, REHS9111, "Installation Procedure for the Pro Product Link PL641 and PL631 Systems"
- Special Instruction, M0098124, "Installation Procedure for Pro Product Link PL243 Systems"
- Special Instruction, M0109130, "Installation Procedure for Product Link PL683 and PL783 Systems"

i08258164

## Machine Security System (MSS)

SMCS Code: 7631

### General Information

#### NOTICE

This machine is equipped with a Cat<sup>®</sup> Machine Security System (MSS) that is designed to restrict operation of the machine. The system can be enabled or disabled, unless the machine is equipped with the optional push to start system. If equipped with the push to start system, machine security will always be enabled. Machines equipped with "push to start", also feature the Cat Bluetooth<sup>®</sup> key fob entry system.

Any user may start the engine and operate the machine if the security system has been disabled.



Illustration 105

g06223917

Machines that are equipped with Cat MSS can be identified by a decal in the operator station. Read the following information and know your machine's settings. Your Cat dealer can identify your machine settings.

The Cat Machine Security System (MSS) discourages unwanted operation of a machine. When armed, the MSS requires operator login to start the engine. The following methods of operator login to disarm the security system are available:

- Cat Bluetooth<sup>®</sup> key fob
- Cat myEquipment mobile application

- Passcode

## Components

The Machine Security System (MSS) consists of the following components:

- Engine start switch
- Electronic Control Module (ECM)
- Machine display
- Optional Cat Bluetooth key fob (CATBTFOB)
- Optional Bluetooth transceiver module (CATBTNT)

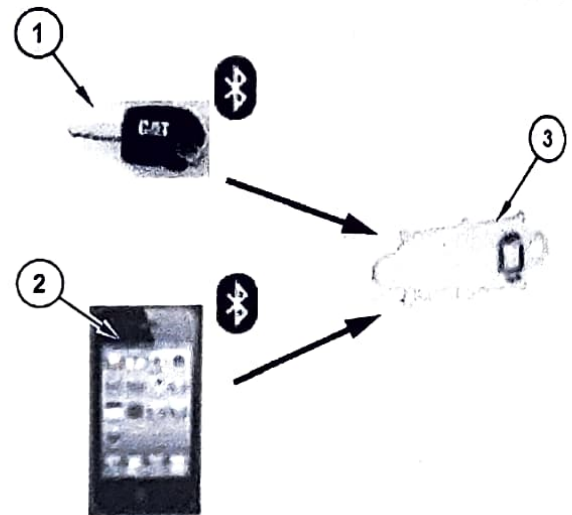

Illustration 106

g06212167

### Bluetooth Connections

- (1) Cat Bluetooth key fob (CATBTFOB)
- (2) Smart phone application
- (3) Cat Bluetooth transceiver (CATBTNT)

The Cat Bluetooth key fob (1) contains an electronic chip. The electronic chip has a unique identification number (ID). A Bluetooth transceiver is mounted in the cab to read the ID of the key. The Bluetooth transceiver module translates the information received from the key fob into a J1939 message. This message is sent to the Electronic Control Module (ECM) that is connected to the MSS. The ECM is typically the Machine ECM. The ECM is set up with the ID of the keys of the intended users.

When the MSS is armed, the ECM validates the ID of the key fob. If the key ID is on the list of authorized keys in the ECM and the key is valid, the machine will operate normally. If the key ID is not on the list of authorized keys in the ECM or is not valid, the MSS will keep the critical machine functions disabled.

If the MSS is not enabled, the operator can skip the login and the machine will operate normally.

## Standard Key

The machine security can be enabled or disabled using the Cat® Electronic Technician (Cat ET) Service Tool or within the display security settings screen (password protected). A master level access passcode must have been used to access the machine security settings in the display. If a standard level passcode was used, the user will be prompted to enter a master level passcode when accessing the machine security passcode screen.

If machine security is enabled, the display will prompt the user to enter a 4-digit numerical passcode when the machine is turned on. Prior to entering an authorized passcode, the engine starter will be disabled and you will not be allowed to proceed to the display home screen. After an authorized passcode has been entered, the display will proceed to the home screen and the engine will be allowed to start.

When turning off the key, the display will prompt the user to select between three options:

- Lock Now – Enables machine security 30 seconds after selected, will have to reenter passcode next time the machine is turned on.
- Wait XX Min – Waits the specified period of time (grace period) to enable machine security, will not have to reenter the passcode if machine is turned back on within the stated time.
- Unlimited – Does not enable machine security, will not have to reenter passcode the next time the machine is turned on.

**Note:** Selecting unlimited does not permanently disable machine security. The user will be prompted with the same three option above the next time the machine is turned on then back off.

The grace period can be adjusted within the display security settings screen (password protected). The time can be adjusted from 1 to 60 minutes.

## Push to Start with Bluetooth Key Fob

If the machine is equipped with push to start and the Bluetooth key fob system, the machine will attempt to detect a Bluetooth key fob when the machine is turned on. If an authorized key fob is detected, the display will immediately proceed to the home screen and the engine will be allowed to start.

**Note:** The bluetooth key can be detected when it is outside the cab if it is in close proximity to the machine. Ensure the bluetooth key is in a sufficient distance from the machine when not in use to prevent unauthorized access to the machine.

**Note:** The bluetooth key fob features a sleep mode to preserve battery life. If the key detects no movement for 90 seconds, it will go into sleep mode and stop communicating. While in sleep mode, it cannot be used to access a machine. The bluetooth key will exit sleep mode and begin communicating after movement of the key is detected. When not in sleep mode, the bluetooth key communicates every 5 seconds.

**Note:** If multiple key fobs are present, the first valid key fob detected by the transceiver will be read. If the machine is not able to detect a key fob when it is turned on, the display will prompt the user to enter a 4-digit numerical passcode.

When the machine is turned off, the display will prompt the user with only the Lock Now and Wait XX Min options. Unlimited option is not available on machine equipped with push to start.

## Adding and Removing Passcodes and Bluetooth Key Fobs

Passcodes and Bluetooth key fobs can be added and removed using the Cat® Electronic Technician (Cat ET) Service Tool or within the display security settings screen (password protected). A master level access passcode must have been used to access the machine security settings in the display. If a standard level passcode was used, the user will be prompted to enter a master level passcode when accessing the machine security passcode screen.

When adding a passcode or Bluetooth key fob, the user will be prompted to select the access level. A summary of the access levels is below.

**Standard** – A standard operator is a registered user of the machine. Operators with this access level can start the engine. This user may save a control configuration for future application.

**Master** – Master accounts can enable/disable machine security and add/remove passcodes in addition to all standard level functions.



## Armed

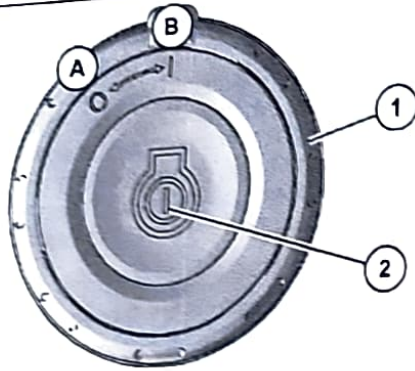

Illustration 107

- (A) Off
- (B) On
- (1) Engine start switch ring
- (2) Engine start button

**Engine Start Ring Switch Position ON** – When the engine start switch ring is first moved to the ON position, the display boots up and the system attempts to detect a Bluetooth key ID or mobile application ID. The ECM will continue reading until a valid key ID is read or a passcode is entered.

## Disarmed

MSS can be disabled through the service menu.

## Camera (If Equipped)

SMCS Code: 7347; 7348

## Rear View Camera



Illustration 108

The rear view camera system consists of a camera that is located in the middle of the top of the counterweight.

**Note:** The rear view camera system has been set up by the factory or by a Cat dealer to provide views which comply with specified guidelines. Consult your Cat dealer before any adjustments are made to the system.

For more information refer to Operation and Maintenance Manual, "Monitoring System".

i08481128

## Monitoring System

SMCS Code: 7451; 7490

The monitoring system alerts the operator of a problem or of an impending problem. The monitoring panel is designed to alert the operator of faulty machine systems. When powering on the panel, there will be an LED test for the first 2 seconds (all LEDs on). The monitoring system consists of the following components:

- Display (with numerous screens and menus)
- Indicators

Two display options are available:

- Performance - Analog gauges and Liquid Crystal Display (LCD) with push-button interface.
- Premium - Full LCD with touchscreen interface.

Most display images in this document are from the performance display. However, the navigation and general functionality is common between the two displays for most features. When the functionality is different, supplemental screen images and details are provided.

**Reference:** For more information on the monitor functions, refer to Systems Operation, M0090757, "Monitoring System" for the performance display and Systems Operation, M0091327, "Monitoring System" for the premium display.

## Performance Display

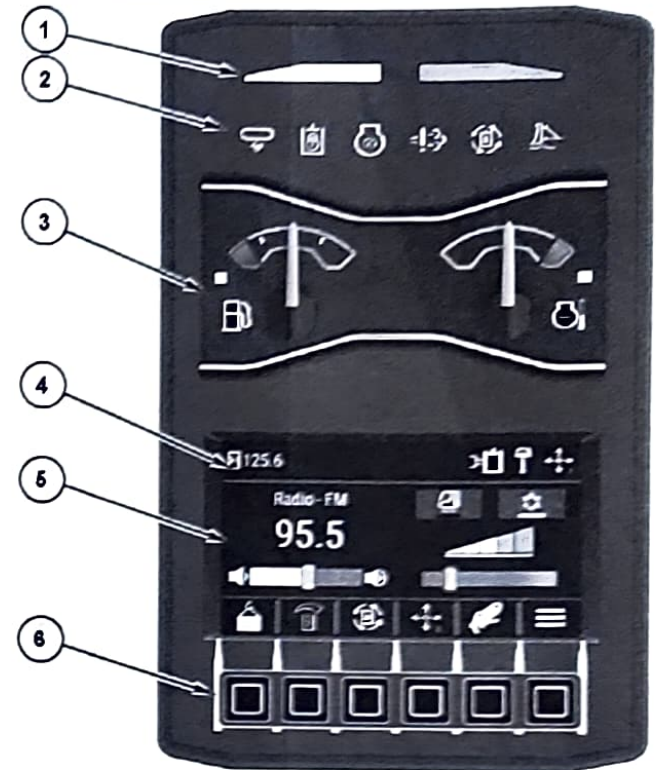

Illustration 109

g06347988

### Home screen

- (1) Action Lamps
- (2) Status Indicator Area
- (3) Gauge Area
- (4) Status Information Area
- (5) Cabin Status Area
- (6) Navigation Buttons

### Action Lamps (1)

The action lamps illuminate to show that a problem has occurred with the machine.



## Status Indicators (2)

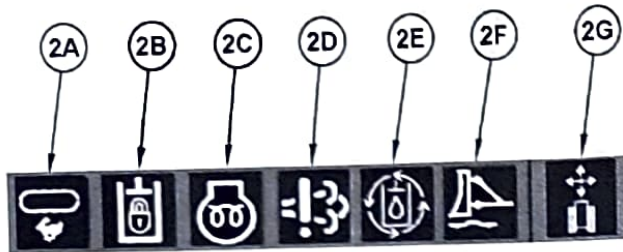

Illustration 110

g06274544

### Travel Speed Indicator (2A)



(2A) Travel Speed – If the travel speed switch is moved to the high-speed position, the high-speed travel indicator illuminates.

### Hydraulic Pilot Supply Solenoid Status Indicator (2B)



(2B) Hydraulic Pilot Supply Solenoid – Indicator (2B) will illuminate when the hydraulic system is locked out (left arm bar raised).

### Glow Plug Indicator (2C)



(2C) Glow Plug – The alert indicator will illuminate when the engine start switch key is turned to the RUN position. After the glow plugs warm up, the LED will go out and the engine can be started. Refer to Operation and Maintenance Manual, "Engine Starting". If the alert indicator does not turn off, consult your Cat® dealer.

### Engine Emission System Indicator (2D)



(2D) Engine Emission System Malfunction – Indicator (2D) will illuminate when there is a fault with the engine emission system.

### Continuous Flow (2E)



(2E) Continuous Flow – Indicator (2E) will illuminate in amber color when continuous hydraulic oil flow is ENABLED. The icon will appear green when continuous flow is active.

### Blade Float Indicator (2F)



(2F) Blade Float – Indicator (2F) will illuminate when the blade float feature is ACTIVE.

### Joystick Steering Indicator (2G)



(2G) Joystick Steering Control – Indicator (2G) will illuminate when joystick steering control status is ACTIVE. This indicator is located between the gauges in area (3).

### Gauge Area (3)

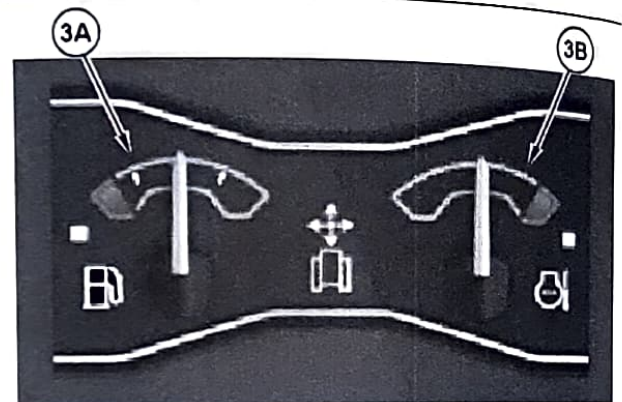

Illustration 111

g06274545

### Fuel Level (3A)



Fuel Level – This gauge indicates the amount of fuel that is remaining in the fuel tank. When the fuel gauge is in the red range, add fuel immediately.

### Engine Coolant Temperature (3B)



Engine Coolant Temperature – This gauge indicates the temperature of the engine coolant. The normal operating range is when the indicator is below the red area and not resting in the full left position. Refer to Operation and Maintenance Manual, "Engine and Machine warmup". If the gauge reaches the red range, stop the machine and investigate the cause of the problem.

## Status Information Area (4)

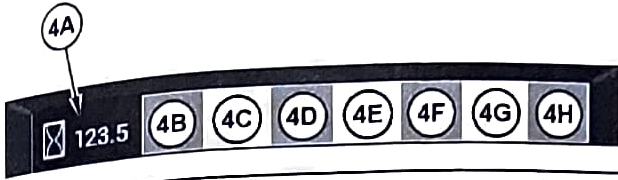



Illustration 112  
(4A) Service Hour meter

g06346172

There are seven icon locations to the right of service hour meter (4A). All possible indicators for each location are shown below.

### Service Hour Meter (4A)

 (4A) Service Hour Meter – Shows the total operating hours of the engine. Use the display to determine the service-hour maintenance intervals.

### Location (4B)

(4B) Cruise Control – ON

(4B) Cruise Control – SET

### Location (4C)

 (4C) Throttle Dial Position – Indicates the engine speed dial setting.

 (4C) Active Auto Idle Control – Auto Idle Control has lowered the engine speed or the Diesel Particulate Filter (DPF) is automatically regenerating.

 (4C) Auto Idle Control – Auto Idle Control is enabled, but not currently active.

**Auto Idle Control** – Auto Idle Control is activated to reduce the engine speed to low idle when no active commands are given for 3 seconds. Turn ON or turn OFF this feature using the monitor.

Auto Idle Control feature allows the operator to reduce the rpm without touching the engine speed dial. Auto Idle Control is useful when the operator wants to reduce the engine speed to talk to someone or while the operator is waiting for a truck.

### Location (4D)



(4D) Security System Immobilizer – This indicator will cover the Smart Mode icon if a security system immobilizer request has been received from Product Link.



(4D) Smart Mode – This indicator shows that the machine is set to operate in Power On Demand (POD).

### Location (4E)



(4E) Shovel Crane (if equipped) – This indicator will illuminate when the shovel crane feature is ON.



(4E) Thumbwheel Mode – This indicator will illuminate when this feature is ACTIVE.



(4E) Hammer – This indicator will illuminate when this work tool is chosen.



(4E) Shear – This indicator will illuminate when this work tool is chosen.



(4E) User Defined – This indicator will illuminate when this work tool is chosen.



(4E) Tilt Bucket – This indicator will illuminate when this work tool is chosen.



(4E) Plate Compactor – This indicator will illuminate when this work tool is chosen.



(4E) Auger – This indicator will illuminate when this work tool is chosen.



(4E) Thumb – This indicator will illuminate when this work tool is chosen.



(4E) Mulcher – This indicator will illuminate when this work tool is chosen.



(4E) Brush Cutter – This indicator will illuminate when this work tool is chosen.



(4E) Tilt Coupler – This indicator will illuminate when this work tool is chosen.



**Location (4F)**

(4F) – In Call



(4F) – Bluetooth Connected



(4F) – Bluetooth Enabled

**Location (4G)**



(4G) – High Reach Boom – This icon appears if this function is controlled with the left thumbwheel.



(4G) – Offset Boom – This icon appears if this function is controlled with the left thumbwheel.



(4G) – Boom Swing – This icon appears if this function is controlled with the left thumbwheel.



(4G) – Swing Valve – This icon appears if this function is controlled with the left thumbwheel.



(4G) – Auxiliary Valve 2 – This icon appears if this function is controlled with the left thumbwheel.

**Location (4H)**



(4H) Joystick Pattern – This icon position combines Pattern Changer and Joystick Steering Pattern. The number on the upper left represents the Pattern Changer value. The number in the upper left portion of the icon indicates if an alternate control pattern is selected. The letter in the upper right corner reflects the joystick steering pattern for the right joystick. Refer to "Joystick Controls" and "Joystick Controls Alternate Patterns" sections for more information.

**Cabin Status (5)**

Depending upon installed features various information is available in this area. Use of the jog dial can also scroll information between the various available screens.

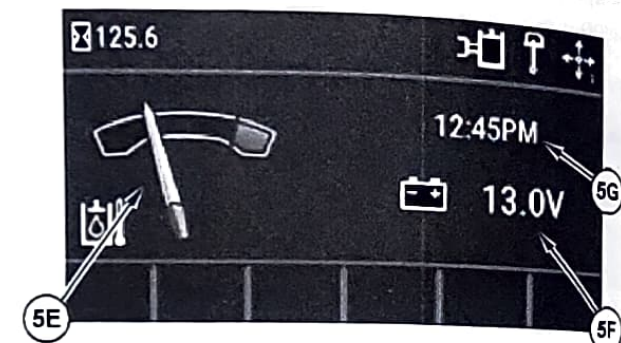
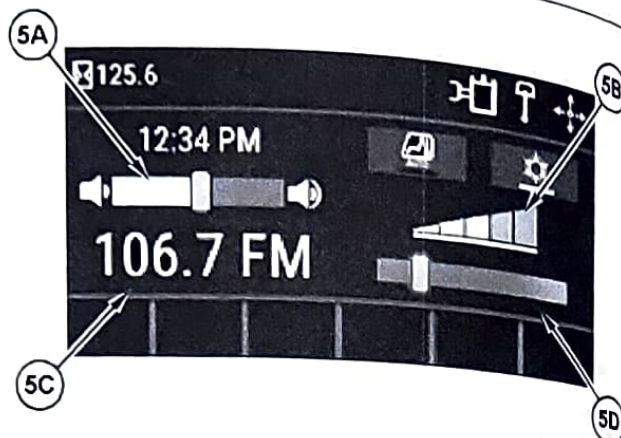

Illustration 113

g06390246

View of status area

With and without Radio and HVAC installed

**Radio Volume (5A)**

Radio Volume (5A) – The radio volume function displays the current volume.

**Air Conditioning Fan Speed (5B)**

Air Conditioning Fan Speed (5B) – The air conditioning fan speed function displays the current fan speed.

**Radio Display (5C)**

Radio Display (5C) – The radio display area will display radio station, Bluetooth audio, Aux audio input, or DAB information.

**Air Temperature (5D)**

Air Temperature (5D) – The air temperature function controls the temperature of the air coming out of the vents.

**Hydraulic Temperature (5E)**

Hydraulic Temperature (5E) – The current temperature of the machine hydraulic oil.

**Battery Voltage (5F)**

**Battery Voltage (5F)** – The current voltage of the machine battery.

**Note:** The hydraulic temperature gauge and battery voltage are accessible on machines with a radio and heat / air conditioning. To access them, either highlight the heat / air conditioning on the cabin status screen and use jog dial to jog to the right, or highlight the radio on cabin status screen and use the jog dial to jog to the left.

**Clock (5G)**

**Clock (5G)** – If equipped, will display the time of day.

**Navigation Buttons (6)**

Illustration 114

g06330261

Navigation buttons (6A) through (6E) are programmable shortcuts. The shortcuts will be automatically populated based on how the machine is configured. To view the complete list or change a shortcut, navigate to the "Shortcut Settings" under the "Display Settings" menu on the monitor. Button (6F) accesses the main menu options available in the Monitoring System. The following sections detail the available options.

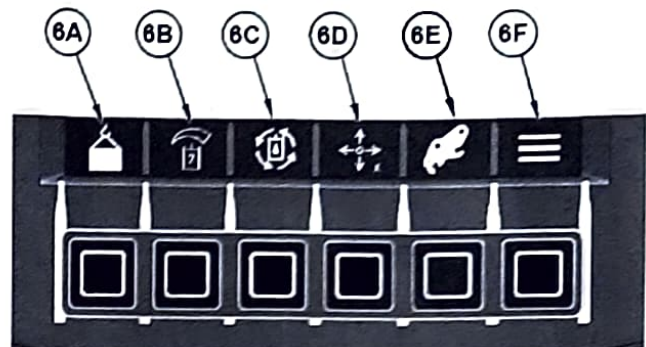

## Premium Display



Illustration 115

g06564012

- (1) Action Lamps
- (2) Status Information Area
- (3) Camera View Area
- (4) Cabin Status Area
- (5) Gauge Area
- (6) Menu
- (7) Shortcuts

The monitoring system displays various warnings and information about the condition of the machine, and the machines surrounding with the rear view camera (if equipped). There are gauges and several alert indicators included on monitoring system display. Each gauge is dedicated to a parameter within a machine system. The monitoring system will allow the user to do the following:

- View surroundings
- Interpret status information
- Interpret parameters
- Troubleshoot machine systems

### Action Lamps (1)

The action lamps illuminate to show that a problem has occurred with the machine

## Status Information Area (2)



Illustration 116

g06617613

(2A) Service Hour Meter - Shows the total operating hours of the machine.

(2B) Clock

(2C) Machine Roll Indicator – Shows the side to side angle degree of the machine. The angle indication is limited to  $\pm 10$  degrees.

(2D) Machine Pitch Indicator – Shows the fore and aft angle degree of the machine. The angle indication is limited to  $\pm 10$  degrees.

### Camera View Area (3)

The camera view area shows live feed of the rear view camera (if equipped).

### Cabin Status Area (4)

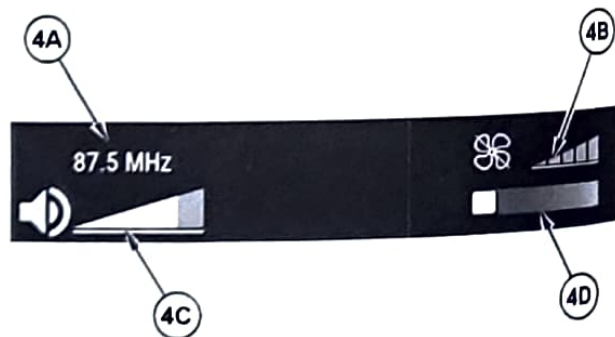

Illustration 117

g06565233

The cabin status screens will change based on the machine configuration. The example shown above is for a machine equipped with both a radio and heat/air conditioning. If the machine is not equipped with one or both of those options, the corresponding area will be blank.

### Radio Station (4A)

**Radio Station (4A)** – The radio station function displays station that is playing.

### Air Conditioning Fan Speed (4B)

**Air Conditioning Fan Speed (4B)** – The air conditioning fan speed function displays the current fan speed.

### Radio Volume (4C)

**Radio Volume (4C)** – The radio volume function displays the current volume.

### Cab Temperature (4D)

**Cab Temperature (4D)** – The cab temperature function displays the temperature setting of the air coming out of the vents.

### Gauge Area (5)

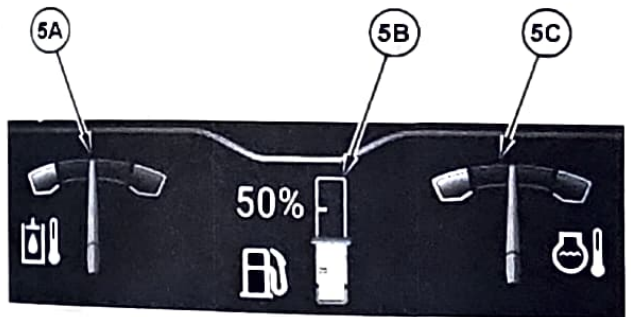

Illustration 118 g08617616

### Hydraulic Oil Temperature (5A)

**Hydraulic Oil Temperature** – This gauge indicates the temperature of the hydraulic oil. If the gauge reaches the red range, stop the machine and investigate the cause of the problem.

### Fuel Level (5B)

**Fuel Level** – This gauge indicates the amount of fuel that is remaining in the fuel tank. When the fuel gauge is in the red range, add fuel immediately.

### Engine Coolant Temperature (5C)



**Engine Coolant Temperature** – This gauge indicates the temperature of the engine coolant. If the gauge reaches the red range, stop the machine and investigate the cause of the problem.

### Menu Button (6)



**Menu Button (6)** – Press the menu button to go to the main menu of display to adjust various machine and display settings.

### Shortcuts (7)

Navigation buttons (7) are programmable shortcuts. The shortcuts will be automatically populated based on how the machine is configured. To view the complete list or change a shortcut, navigate to the "Shortcut Settings" under the "Display Settings" menu on the monitor.

### Main Menu

The following sections detail available options within the menu structure of the display.

### Machine Settings

Machine settings adjust various options which control machine functions. Certain settings may require the engine to be OFF for adjustment.

Included in machine settings are the following:

- Control Mode
- Aux/Work Tool
- Auto Idle Control
- Machine Lighting
- Factory Defaults

### Control Mode

Control mode contains several settings that affect machine operation.

Included in this subsection is descriptions of Pattern Changer, Cruise Control, Joystick Steering Pattern, Engine Idle Shutdown (if equipped), Fine Grading, Implement Speed, Joystick Response, Forward Travel Trim, and Reverse Travel Trim.



## Pattern Changer

The pattern changer allows the selection of various control patterns for the left and right joystick. Refer to "Joystick Controls Alternate Patterns" for details of available patterns

### Joystick Steering Pattern

Joystick steering Pattern allows for the selection of desired function of the right joystick lever while in stick-steer mode. Refer to "Joystick Controls" for more details

### Fine Grading

The Fine Grading mode increases the fine control of the machine implement functions. When Enabled, the pump will generally operate at a higher pressure to help achieve greater fine control.

To access Fine Grading, press the "Menu" button, select "Machine Settings", "Control Mode", then "Fine Grading"

Press "OK" to toggle between Enabled and Disabled

### Implement Speed

Implement speed allows the operator to adjust the joystick sensitivity and function maximum speeds. This parameter is adjusting both the joystick sensitivity and speed of the boom, stick, bucket, and swing together. The Advanced settings menu allows for individual adjustment.

To access the Implement Speed options, press the "Menu" button, select "Machine Settings", "Control Mode", then "Implement Speed"

Select the desired option using the up and down arrows, then press "OK"

### Advanced

To access the Advanced options, press the "Menu" button, select "Machine Settings", "Control Mode", "Implement Speed", then "Advanced"



Illustration 119

g06333802

Select the desired option using the up and down arrows, then press "OK"

The following are the options within each:

- Normal
- Fast
- Slow

### Joystick Response

Joystick response allows the operator to adjust the implement response to the joystick inputs. This parameter is adjusting the joystick response of the boom, stick, bucket, and swing together. The Advanced settings menu allows for individual adjustment.

Adjusting the implement response rate will change how abrupt the implements start and stop, affecting the smoothness of operation of the machine.

To access the Joystick Response options, press the "Menu" button, select "Machine Settings", "Control Mode", then "Joystick Response"

Select the desired option using the up and down arrows, then press "OK"

### Advanced

To access the Advanced options, press the "Menu" button, select "Machine Settings", "Control Mode", "Joystick Response", then "Advanced"



Illustration 120

g06333802

Select the desired option using the up and down arrows, then press "OK".

The following are the options within each:

- Normal
- Slow
- Fast

### Cruise Control

To enable cruise control feature in the monitor press the "Menu" button, select "Machine Settings", "Control Mode", "Cruise Control" then press "OK". Once enabled, cruise control can be activated as indicated in the "Joystick Controls" section.

The cruise control can be added to the shortcut menu in the monitor if desired. Each time the machine is powered ON, the cruise control feature must be enabled.

## ⚠ WARNING

A seat belt should be worn at all times during machine operation to prevent serious injury or death in the event of an accident or machine overturn. Failure to wear a seat belt during machine operation may result in serious injury or death.

Do not mount a moving machine. Do not dismount a moving machine. Never jump off the machine. Do not carry tools or supplies when you try to mount the machine or when you try to dismount the machine. Use a hand line to pull equipment onto the platform. Do not use any controls as handholds when you enter the operator compartment or when you exit the operator compartment.

### Forward Travel Trim

Forward travel trim allows the operator to make fine adjustments between the left and right track speed in the FORWARD direction to correct any drift or wandering.

To access the Forward Travel Trim options, press the "Menu" button, select "Machine Settings", "Control Mode", then "Forward Travel Trim".

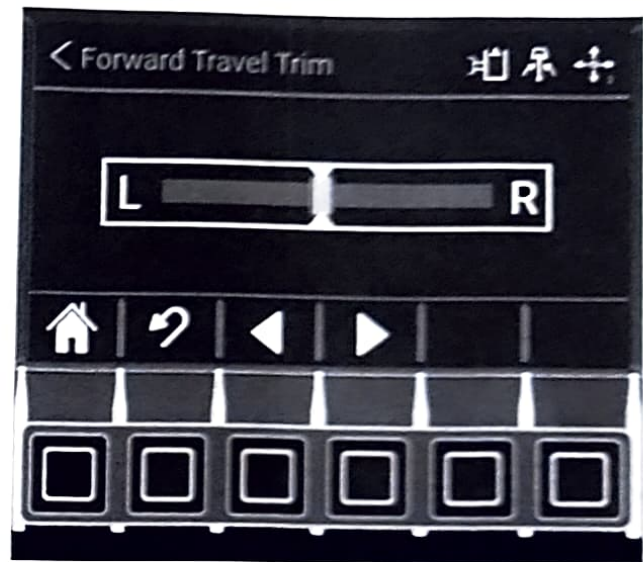

Illustration 121

g06333952

To adjust the forward travel trim, use the right and left arrows.

If your machine drifts RIGHT, then move the arrow to the LEFT.

### Reverse Travel Trim

Reverse travel trim allows the operator to make fine adjustments between the left and right track speed in the REVERSE direction to correct any drift or wandering.

To access the Reverse Travel Trim options, press the "Menu" button, select "Machine Settings", "Control Mode", then "Reverse Travel Trim".



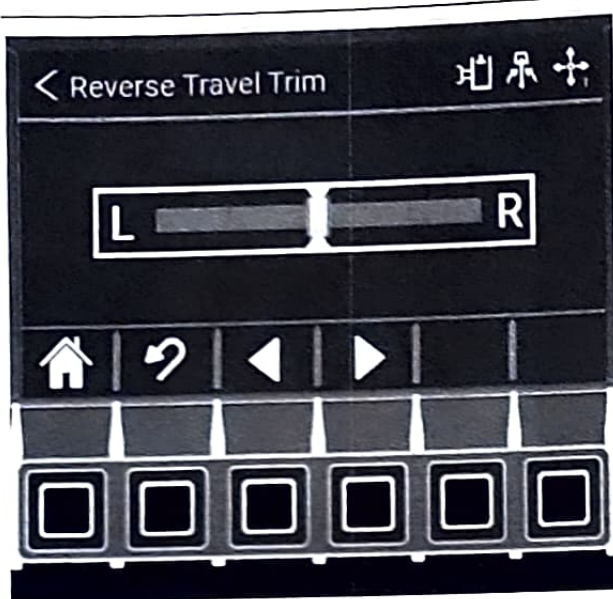

Illustration 122

g06333956

To adjust the reverse travel trim, use the right and left arrows.

If your machine drifts RIGHT, then move the arrow to the LEFT.

### Engine Idle Shutdown

Engine Idle Shutdown feature automatically shuts off the engine when the following conditions are met for 3 to 15 minutes :

- Arm bar is raised
- Coolant temperature is above 50° C (122° F)
- Work lights are OFF
- Auto engine idle feature is enabled
- Throttle dial position is less than seven
- No active DPF regeneration

The engine idle shutdown feature must be enabled for the function to be active. To enable, press the "Menu" button, select "Service Mode", "Machine", "Engine Idle Shutdown", then press OK.

Once enabled, the timer can be adjusted by pressing the "Menu" button, "Machine Settings", "Control Mode", then "Engine Idle Shutdown". The idle time is adjustable from 3 to 15 minutes in increment of 1 minute. Press OK to confirm the selection.

### Aux/Work Tool

The Aux/Work Tool submenu allows for configuration of the auxiliary hydraulics of the machine.

Included in this subsection is descriptions of Continuous Flow, Quick Coupler, Aux Flow 1 (if equipped), Aux Flow 1 Balance (if equipped), Aux Flow 2 (if equipped), Tiltrotator (if equipped), Aux Flow 2 Balance (if equipped), and Work Tool Select.

### Continuous Flow

To enable the continuous flow feature in the monitor press the "Menu" button, select "Machine Settings", "Aux / Work Tool", "Continuous Flow" then OK. Once enabled, continuous flow can be activated as indicated in the "Continuous Flow" section.

The continuous flow enable can be added to the shortcut menu in the monitor if desired. Each time the machine is powered on, the continuous flow feature must be enabled.

### Quick Coupler (If Equipped)

This menu allows for activation of a hydraulic quick coupler. Two types of couplers are supported including dual lock and single lock couplers. Dual lock couplers will show two screens indicating the status of each individual locking mechanism. Single lock couplers have only a single screen allowing for lock and unlock functions of the coupler. To access the Hydraulic Quick Coupler in the monitor press the "Menu" button, "Machine Settings", "Aux / Work Tool", then "Quick Coupler". The Single Lock or Dual Lock quick coupler screen will be selected automatically based on which quick coupler the machine is configured with.

The quick coupler control screen can be added to the shortcut menu in the monitor if desired.

### Tiltrotator (If Equipped)

The Tiltrotator is a specialized worktool that can be purchased for the machine. Refer to the Tiltrotator Operation and Maintenance Manual for more details or contact your dealer for information.

### Aux Flow 1 (If Equipped)

Aux 1 Flow allows for metering the flow provided to the auxiliary 1 circuit. To adjust the aux 1 flow press the "Menu" button, select "Machine Settings", "AUX / Work Tool", "Aux Flow 1" then adjust the flow rate. The flow is adjustable from 10 percentage to 100 percentage in increments of 10 percent.

The aux flow 1 can be added to the shortcut menu in the monitor if desired.

### Aux Flow 1 Balance (If Equipped)

Aux Flow 1 Balance allows for reducing the flow to the aux 1 A port or aux 1 B port for work tools that require different flow rates in each direction.



To adjust the aux flow 1 balance press the "Menu" button, select "Machine Settings", "Aux / Work Tool", "Aux Flow 1 Balance" then adjust the balance as desired. When the slider is in the MIDDLE position, the supply flow rate is the same to both ports. Adjusting the slider to the LEFT will reduce the flow rate to the right (aux 1 A) port but maintain same flow rate to the left (aux 1 B) port. Adjusting the slider to the RIGHT will reduce the flow rate to the left (aux 1 B) port but maintain the same flow rate to the right (aux 1 A) port.

### Aux Flow 2 (If Equipped)

Aux 2 Flow allows for metering the flow provided to the auxiliary 2 circuit. To adjust the aux 2 flow press the "Menu" button, select "Machine settings", "Aux / Work Tool", "Aux Flow 2" then adjust the flow rate. The flow is adjustable from 10 percentage to 100 percentage in increments of 10 percent.

The aux flow 2 can be added to the shortcut menu in the monitor if desired.

### Aux Flow 2 Balance (If Equipped)

Aux Flow 2 Balance allows for reducing the flow to the aux 2 A port or aux 2 B port for work tools that require different flow rates in each direction.

To adjust the aux flow 2 balance press the "Menu" button, select "Machine Settings", "Aux / Work Tool", "Aux Flow 2 Balance" then adjust the balance as desired. When the slider is in the MIDDLE position, the supply flow rate is the same to both ports. Adjusting the slider to the LEFT will reduce the flow rate to the right (aux 2 A) port but maintain same flow rate to the left (aux 2 B) port. Adjusting the slider to the RIGHT will reduce the flow rate to the left (aux 2 B) port but maintain the same flow rate to the right (aux 2 A) port.

### Work Tool Select

Toggling the work tool select, various work tools are available. Selecting the work tool attached to the machine will pick default settings for Aux 1 Flow metering and configure the valve for utilizing work tools.

To select the work tool press the "Menu" button, select "Machine Settings", "Aux / Work Tool", "Work Tool Select" then select the desired tool.

The work tool select can be added to the shortcut menu in the monitor if desired.

Some work tools are designated as heavy tools. When selected, the controls compensate for the additional load on the linkage to maintain optimal multi-functional operation. The following tools are designated as work tools:

- Shear
- Plate Compactor

- Mulcher
- Brush Cutter

**Note:** If the Fine Grading mode is Enabled, the controls will operate with the heavy tool settings, regardless of which work tool is selected.

### Auto Idle Control

Auto idle control automatically reduces engine speed when no implement commands have been issued for 3 seconds. To enable, press the "Menu" button, select "Machine Settings", "Auto Idle Control", then press OK.

Auto idle control can be added to the shortcut menu in the monitor if desired.

### Machine Lighting

**Beacon Light (if equipped)** – Toggles the beacon light ON and OFF. Press the "Menu" button, select "Machine Settings", "Machine Lighting", "Beacon Light", then press OK to toggle between ON and OFF. Beacon light can be added to the shortcut menu in the monitor if desired.

**Courtesy Light** – Courtesy light allows the machine lighting to stay ON after turning the key switch OFF. Courtesy lights illuminate if the work lights were ON when the key was switched OFF. Press the "Menu" button, select "Machine Settings", "Machine Lighting", "Courtesy Light". The timer is adjustable from 0 to 100 seconds in increment of 5 seconds. Press OK to confirm the selection.

### Job Clock

The job clock displays the number of engine running hours that have been accumulated since the last reset. To reset the job clock back to zero, press the "Menu" button, "Machine Settings", "Job Clock", press the RESET button (icon with two parallel lines at a 45 degree angle).

Job Clock can be added to the shortcut menu in the monitor if desired.

### Reset Factory Default

Restores factory default settings for the following parameters :

- Joystick Response
- Implement Speed
- Auxiliary Flow 1
- Auxiliary Flow 1 Balance
- Auxiliary Flow 2
- Auxiliary Flow 2 Balance



- Courtesy Light Timer
- Work Tool Select
- Automatic Engine Idle Control
- Cruise Control
- Beacon Light
- Joystick Steering Pattern

To reset, press the "Menu" button, select "Machine Settings", "Reset Factory Default" then OK.

## Display Settings

Display settings configure the monitoring system on the machine. To access the display settings press the "Menu" button, select "Display Settings", then select the desired display setting to be adjusted. Available settings include Show Camera (if equipped), Brightness, Clock Adjust (if equipped), Language, Units, Clock Format (if equipped), and Shortcut Settings

**Shortcut Settings** – Shortcut settings are configurable allowing for direct access to submenu options on the monitoring system using the Navigation Buttons

The following shortcut settings can be selected :

- Pattern Changer
- Quick Coupler
- Performance
- Camera
- Auto Idle
- Continuous Flow
- Work Tool Select
- Aux Flow 1
- Aux Flow 2
- HVAC
- Radio
- Audio Source
- Shovel Crane (If Equipped)
- Bluetooth ON / OFF
- Tiltrotator
- Cruise Control

- Beacon Light
- Joystick Steering Pattern
- Job Clock
- Blank (none)

## HVAC (If Equipped)

Accesses the cab climate control system. Refer to the Air Conditioning and Heating Control section for more information.

## Radio (If Equipped)

Accesses the radio controls of the machine. Refer to the Radio section for more details on how to operate.

## Information

Accesses the performance and ECM summary submenus.

**Performance** – Displays sensor parameters available on the machine such as engine speed and pump pressure. To access the performance information press the "Menu" button, select "Information", then "Performance."

**ECM Summary** – Displays software version information for the machine, display, and other electronic components installed on the machine. To access the ECM summary press the "Menu" button, select "Information", then "ECM summary."

## Service

Includes submenus showing diagnostics and service mode.

Contact your dealer for more information about menu items not disclosed in this manual.

## Diagnostics

Reports fault code information used for troubleshooting.

### Service Mode

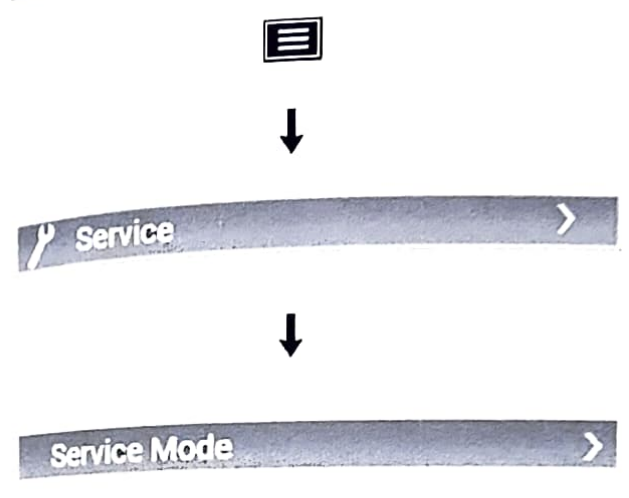

Illustration 123 g06334877

To access the Service Mode Menu options, press the "Menu" button, select "Service", then "Service Mode"

This parameter must be ENABLED for the joystick thumbwheel controls to be used.

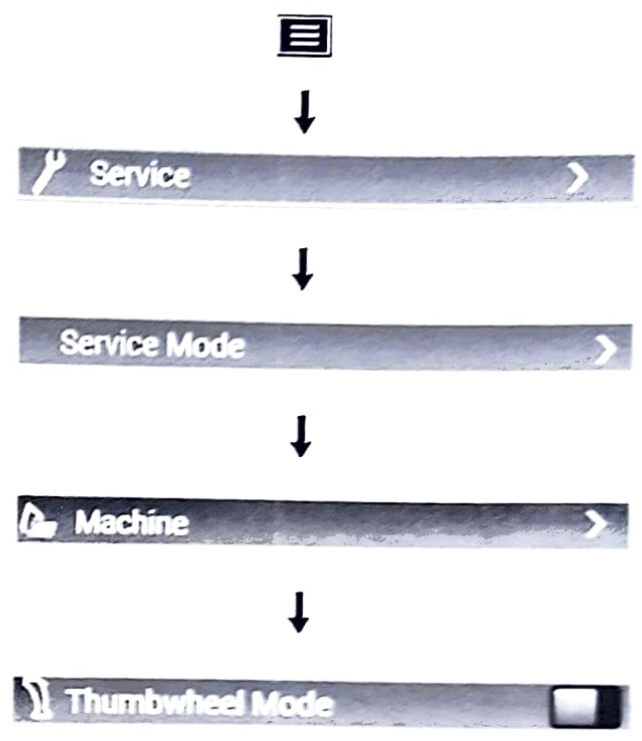

Illustration 125 g06334888

To access the Thumbwheel Mode options, press the "Menu" button, select "Service", "Service Mode", "Machine", then "Thumbwheel Mode"

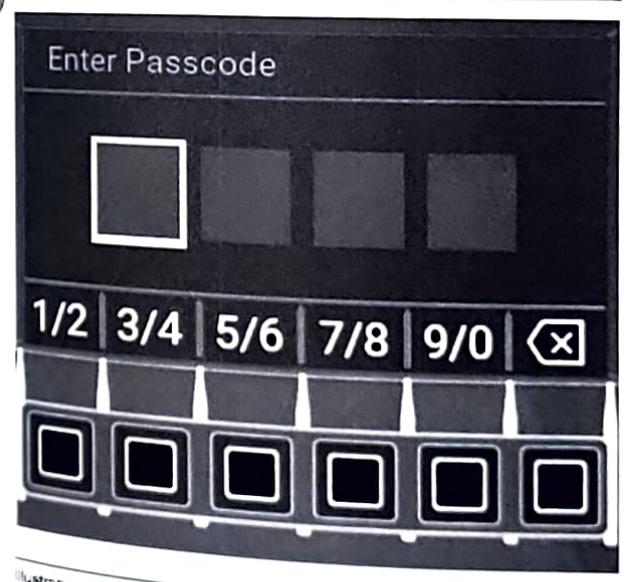

Illustration 124 g06334880

Enter the four-digit service entry password.  
**Note:** Factory set default code is 1234 or 1925.

### Thumbwheel Mode

Thumbwheel Mode allows stick to toggle to right thumb roller when in stick-steer mode. Refer to Operation and Maintenance Manual, "Joystick Controls" for more information.



Illustration 126 g06334888

To enable the Thumbwheel Mode function, select "Thumbwheel Mode" and press "OK"



**Note:** When the indicator is green and the slide is to the right, the feature is activated.

### Security

Machine security can be configured to prevent unregistered access to your machine. Additional security features can be configured using the Monitoring System. To access Security features, press the "Menu" button, select "Service", "Service Mode", then "Security". If security is disabled or a standard security level passcode or bluetooth key was used to access the machine, you will be prompted to enter a master security level passcode when accessing the security screens. The default master passcode from the factory is "1111". This default passcode can be removed after creating a new master passcode.

If security is enabled and a master security level passcode or bluetooth key was used to access the machine, it will proceed directly to the security screens.

### Security Enable

toggling this setting will turn the security system ON or OFF.

### Grace Period

This setting is used to set the duration after key off that the registered user stays logged on to the machine. If the machine is turned ON within this time range, the machine will bypass security access without the use of a Bluetooth key or passcode.

### Users / Keys

The Users / Keys category from the Security Menu allows the owner / technician to enter unique passcodes (PINs) and/or Bluetooth keys (each with a unique ID) which allow those authorized users to start and operate the machine. Also, the owner or authorized technician can delete passcode PINs and Bluetooth key IDs of authorized keys and users.

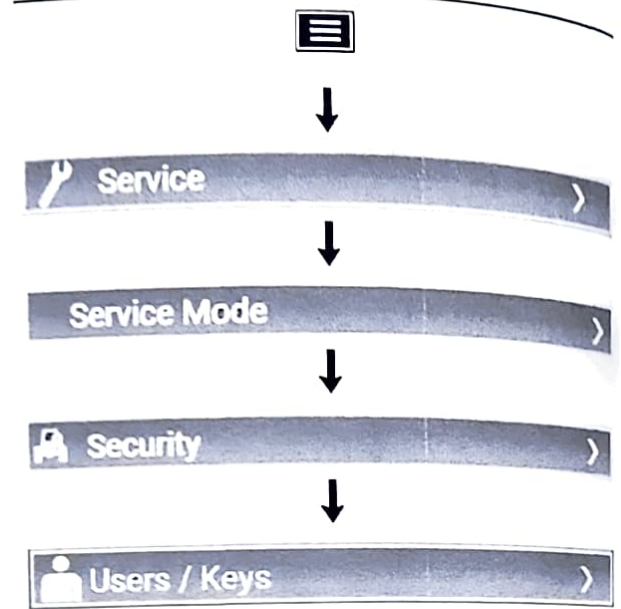

Illustration 127

g06334963

To access the User / Keys options, press the "Menu" button, select "Service", "Service Mode", "Security", then "Users / Keys".



Illustration 128 g06390456

Add PIN



Illustration 129 g06345288

To add a new 4-digit PIN to the passcode list of authorized users, select "Add PIN" from the "Users / Keys" menu



Illustration 130 g06345290

Only a user with a "Master" passcode can enter new "Standard" or "Master" passcodes

**Note:** Standard passcodes are for operators and technicians - Master passcodes are intended for owners or authorized personnel

Multiple Master passcodes can be added to the Master Passcode list. The default master passcode from the factory is "1111". This default passcode can be removed after creating a new master passcode

This same strategy applies to the Bluetooth system, with a Master Bluetooth key used to add or remove Bluetooth keys from the respective lists.

Passcode PINs and Bluetooth key IDs can also be added or removed from the respective lists using Cat ET.

**Note:** A maximum total of 25 passcodes and keys can be added to the machine.



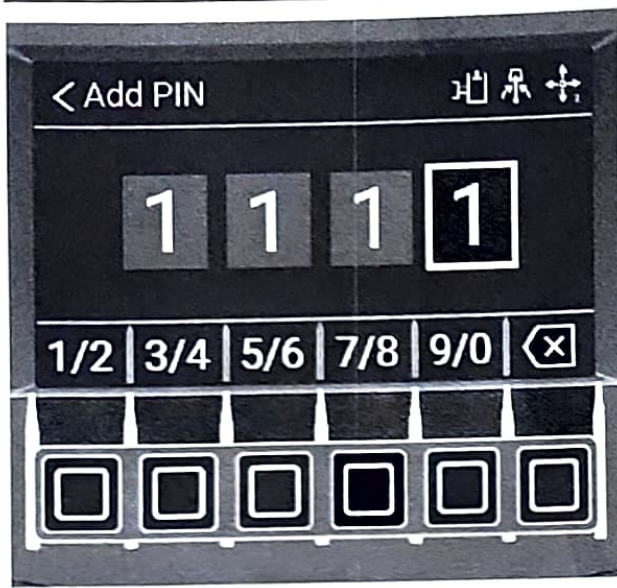

Illustration 131

g06345300

From the Add PIN entry screen, use the number buttons to enter a unique 4-digit passcode number.

**Note:** Each button can enter two numbers. To enter the number two (2), press the left-most "1/2" button twice, then the highlight will move to the next entry field to the right.

Each time a number is entered, the highlight will automatically move to the next space to the right.

Once all four numbers have been entered, the new passcode will be added to the list of authorized PINs. The display will then return to the Keys/Users Menu.

In the example above, when the operator turns the key start switch to ON, the monitor will display the startup passcode entry screen. When the operator enters "1111", the MSS will allow the engine to be started.

## Remove PIN



Illustration 132

g06345316

To remove a new 4-digit PIN to the passcode list of authorized users, select "Remove PIN" from the "Users / Keys" menu.

From the "Remove PIN" entry screen, use the number buttons to enter the 4-digit passcode number that you wish to remove if equipped with the Performance display or select the 4-digit passcode number you wish to remove if equipped with the Premium display.

Press the "OK" button or tap the center of the Jog Dial (if equipped) to remove the 4-digit passcode number from the list of authorized passcodes.

### Add Bluetooth Key



Illustration 133 g06345355

To add a Bluetooth key ID to the list of authorized Bluetooth keys, select "Add Bluetooth Key" from the "Users / Keys" menu.

From the "Users / Keys" menu, use the arrow buttons to highlight the "Add Bluetooth Key" option, then press the "OK" button. The "Add Bluetooth Key" confirmation screen will appear.



Illustration 134 g06345356

Use the arrow buttons to highlight the "Standard" or "Master" option, then press the "OK" button. The "Add Bluetooth Key" screen will be displayed.



Illustration 135 g06345359

Enter the unique 12-digit alpha-numeric ID assigned to the Bluetooth key chip.

The "Add Bluetooth Key" screen is first displayed with all 12 ID spaces blank and the left-most space highlighted. Use the arrow buttons scroll up and down through the numbers 0-9, then alpha characters A-F, which are displayed in the space. When the desired character is displayed in the highlighted space, move to the next space.

**Note:** The highlight can also be moved left to change a number previously entered.

Repeat this process for all 12 spaces. When all 12 spaces have been filled with the unique 12-digit Bluetooth key ID, press the "OK" button or tap the center of the Jog Dial (if equipped) to enter the Bluetooth key ID to the list of authorized Bluetooth IDs.

The display will return to the "Users / Keys" Menu.



**Remove Bluetooth Key**

Illustration 136

g06345381

To remove a 12-digit Bluetooth key ID from the list of authorized Bluetooth key IDs, select "Remove Bluetooth Key" from the "Users / Keys" menu.

Enter the unique 12-digit alpha-numeric ID assigned to the Bluetooth key ID that you wish to remove if equipped with the Performance display or select the Bluetooth Key ID that you wish to remove if equipped with the Premium display.

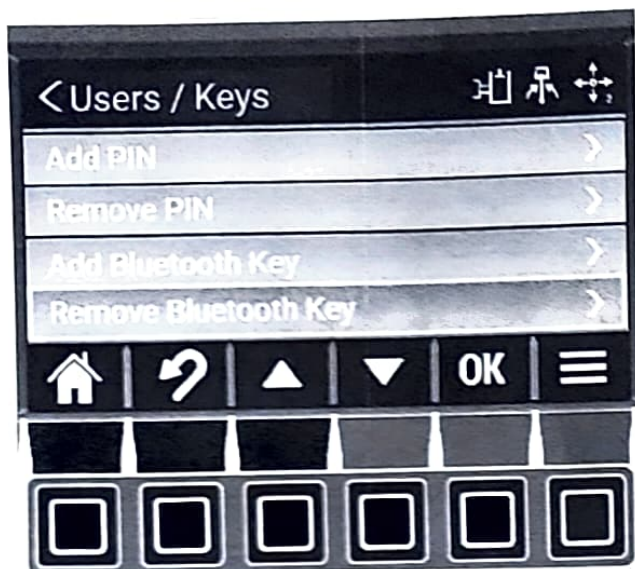
Press the "OK" button or tap the center of the Jog Dial (if equipped) to remove the Bluetooth key ID from the list of authorized Bluetooth IDs.

The display will return to the "Users / Keys" Menu.

**Display System Mode**

The Display System Mode can be changed between Normal and Simplified. When the mode is set to Normal, all available display settings are shown and available for adjustment. When the mode is set to Simplified, the display settings below are hidden and not available for adjustment.

- Fine Grading
- All joystick response settings
- Advanced implement speed settings (overall setting still available)
- Forward travel trim
- Reverse travel trim
- Auxiliary 1 flow balance

- Auxiliary 2 flow balance
- Job clock
- ECM summary
- Machine configurations within service mode

The Simplified Display System Mode is intended for customers who want to limit the adjustability of the machine.

To access the Display System Mode options, press the "Menu" button, select "Service", "Service Mode", then "Display System Mode".

**Monitor Wake-up Feature**

Illustration 137

g06366070

**Monitor wake-up screen example**

Pressing any navigation button on the monitor will display the service hours of the machine and actual fuel level for 2 minutes.

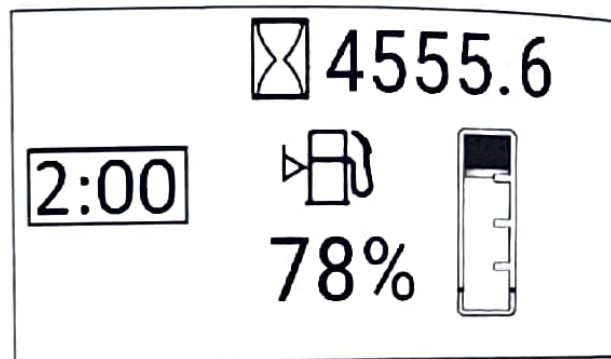
**Note:** This feature can also be activated by pressing the monitor wake-up button located below the seat near the door (if equipped).

i08372949

**Fuel Transfer Pump  
(Refueling)  
(If Equipped)**

**SMCS Code:** 1256

Use the following procedure to pump fuel and store the hose.

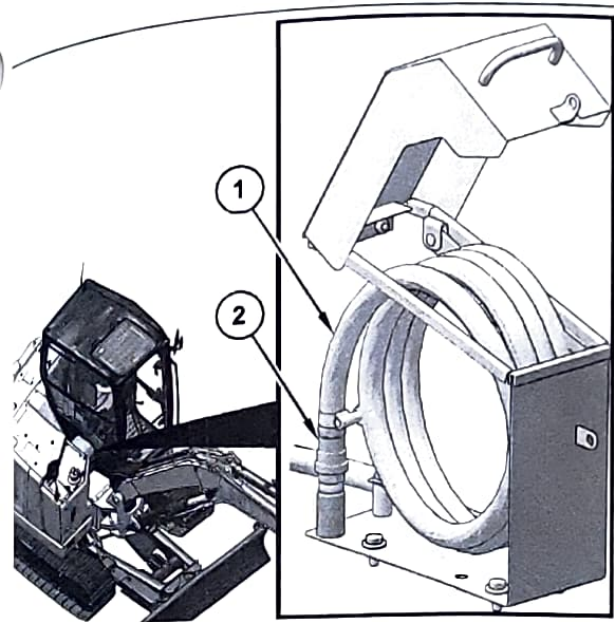

g06349497

3. Suction valve (2) is at the end of hose (1).

**Note:** Suction valve (2) is a check valve and ensures that fuel only flows toward the tank.

Properly insert the end of the suction valve into a container of fuel.

4. Push switch to the ON (middle) position to enable the fuel fill system.

**Note:** The pump will not turn ON yet.

5. Push switch to the RUN (top) position to activate the refuel pump.

Releasing the switch from the RUN position to the ON position within 2 seconds will put the pump in automatic fill mode. In this mode the pump will continue to run until the tank is full. When the tank is full, the pump will automatically stop. To cancel automatic fill mode, push the switch to the OFF (down position). The pump will turn OFF immediately.

If the switch is held in the RUN position for more than 2 seconds, the pump will turn OFF immediately when the switch is released. While the switch is held in the RUN position, the pump will run, even if the tank is full.

6. When done refueling, push the switch to the OFF position.

7. Wind the hose and store in the hose container.

**NOTICE**

To prevent hose damage, do not coil the hose in a tight radius.

Illustration 138  
(1) Suction hose  
(2) Suction valve

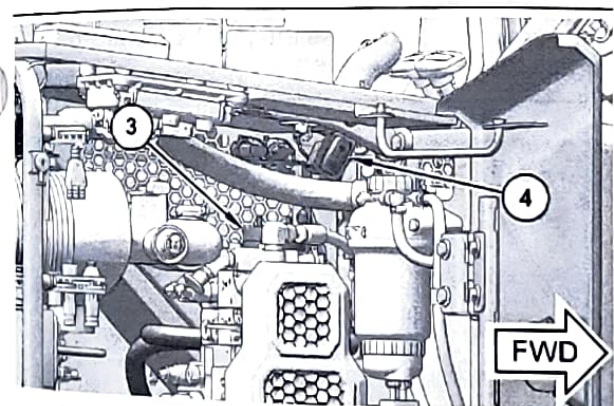

g06349495

8. Close the access door.

108369586

Illustration 139  
(3) Electric refueling pump  
(4) OFF/ON/RUN switch

**OFF/ON/RUN Switch – Push the OFF/ON/RUN switch to activate or deactivate the fuel transfer pump.**

If the battery disconnect switch is in the OFF position or the fuel tank is full, the fuel transfer pump will not activate and/or stop operating.

Use the following procedure to pump fuel and store the hose.

1. Park the machine on a level surface. Move the hydraulic lockout control to the LOCKED position. Stop the engine.
2. Open the access that is on the right side of the machine.

**Radio**

**SMCS Code:** 7338

The radio is integrated into the monitoring system. All the radio controls are adjusted using the monitor. Refer to Operation and Maintenance Manual, Monitoring System. The actual radio amplifier module is located in the headliner behind the operator seat.



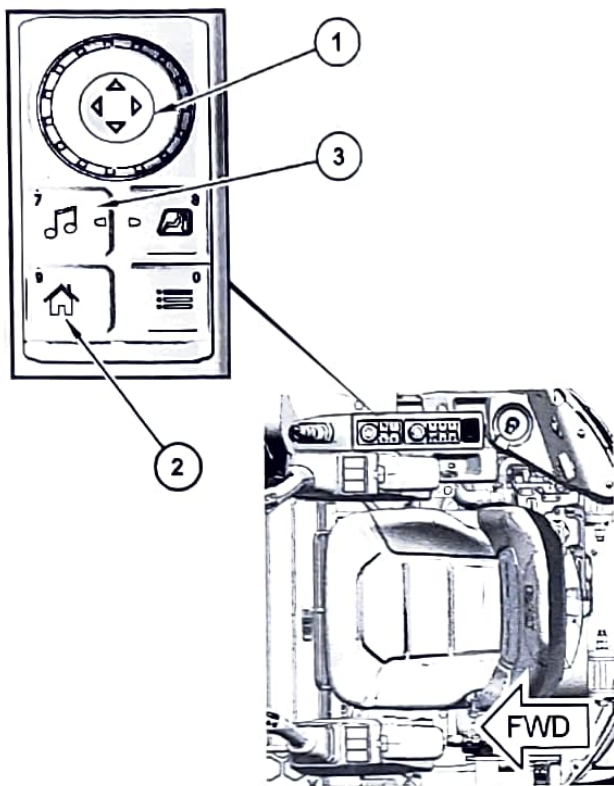

Illustration 140

g06644125

- (1) Jog dial
- (2) Home button
- (3) Radio button

The audio menu can be directly accessed by pressing radio button (3) on the right side switch panel. Input selections can be made using jog dial (1) or using the monitor navigation buttons. Home button (2) can be used to return to the main screen.



Illustration 141

g06348419

Pressing radio button (3) will go directly to the radio screen.

Using the jog dial, select the radio portion of the home screen (4) and press the jog dial inward to navigate to the radio screen.

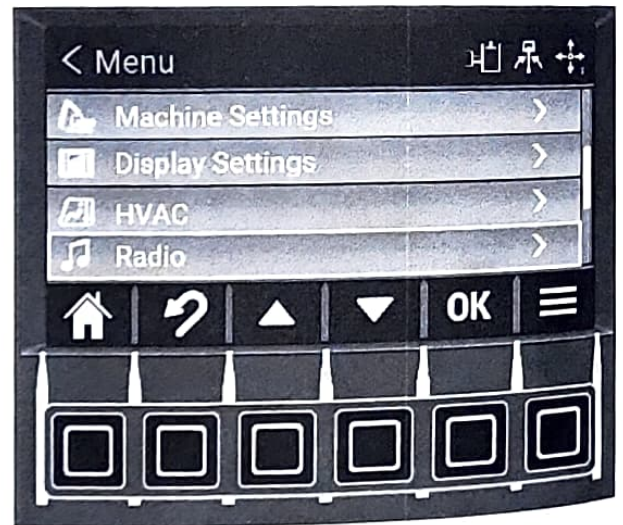
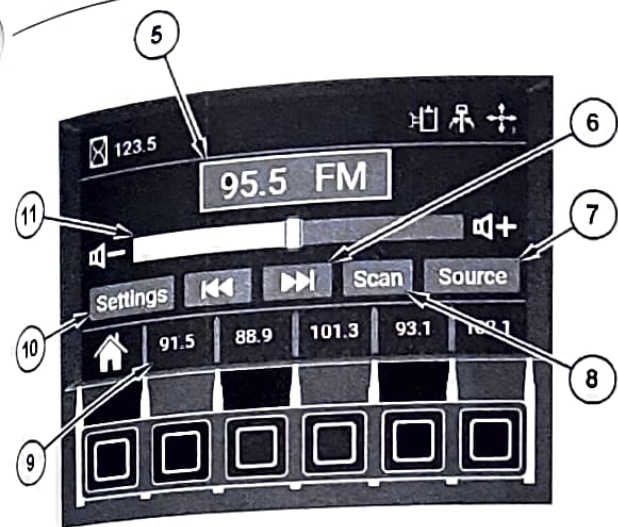

Illustration 142

g06334467

To navigate to the radio screen from the main screen, press the menu button and select "Radio".

- Equalizer
- Bluetooth (Audio)



g06334464

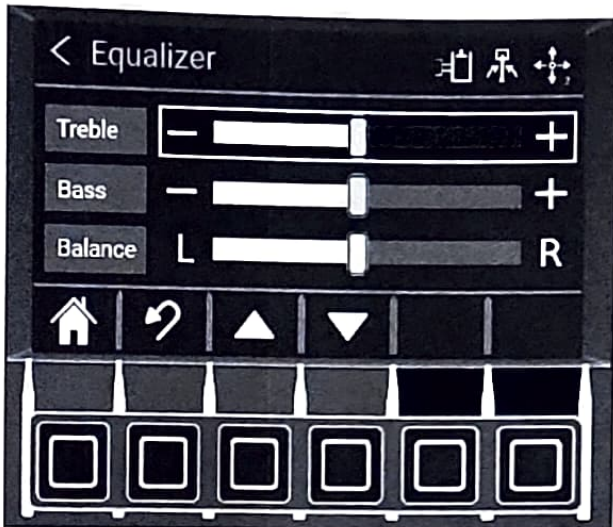

Illustration 144

g06334476

The equalizer menu consists of the following items:

**Treble** – Allows the user to adjust the treble.

**Bass** – Allows the user to adjust the bass.

**Balance** – Allows the user to adjust the balance between speakers.

### Bluetooth

Includes setup option for pairing devices to your machine radio.

### Bluetooth

Toggle switch enables Bluetooth for audio pairing.

### Pairing

This setting makes the machine radio discoverable for pairing on Bluetooth devices.

A maximum of 5 user devices for the performance display and 8 user devices for the premium display can be paired to the machine.

Illustration 143  
Radio screen

- (5) Station
- (6) Seek
- (7) Source list menu
- (8) Scan
- (9) Preset stations
- (10) Radio settings menu
- (11) Volume control

- Station (5)** – Identifies the current station setting.
- Seek (6)** – The seek is used to automatically find the next radio station with a strong/clear signal.
- Source list menu (7)** – Allows the user to change the source of input. (AM, FM, AUX, DAB (if equipped), or Bluetooth)
- Scan (8)** – Automatically sweeps through the broadcast frequencies looking for signal.
- Preset stations (9)** – The preset stations store favorite radio stations for the operator. To set a station, tune to the desired station. Press and hold the preset number you want to assign to that station. Once a beep is heard, release the button. The button will indicate the preset frequency.
- Radio settings menu (10)** – Pressing this button leads to the radio settings menu.
- Volume control (11)** – The volume control is used to raise or lower the audio volume.

### Radio Settings Menu

To access the radio settings menu, select "Settings" from the radio screen.

The following selections are available in the radio settings menu:



## Paired Devices

This setting provides a list of previously paired devices supported by your machine. The previously paired devices can also be removed using this menu option.

## Selection Method

Most settings can be made using the monitor screen or by using the jog dial. Some radio and some air conditioning/heating controls can only be performed using the jog dial. When using the monitor screen, simply touch the button below the icon you want to select. When using the jog dial, rotate the dial to switch to different selections within the screen. Press the jog dial downward to choose a selection.

When using the jog dial to set the volume or tuner, rotate the dial clockwise to increase and counter-clockwise to decrease. Press inward on the dial to enter the desired setting.

## AUX Operation

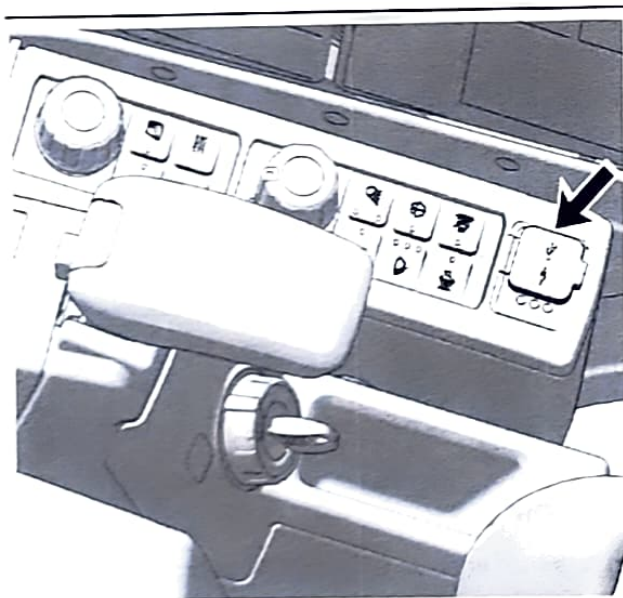

Illustration 145

g06277738

1. To play music from a device such as an MP3 player or a phone, connect the device using an auxiliary cable.
2. Select AUX to play the music from the device. The music should be playing over the radio speakers if properly connected. Adjust the volume as necessary.

**Note:** The USB port is for charging purposes only.

108258327

## Air Conditioning and Heating Control

SMCS Code: 7304; 7320; 7337

Refer to Maintenance Interval Schedule for Periodic Maintenance of the heating and air conditioning system.

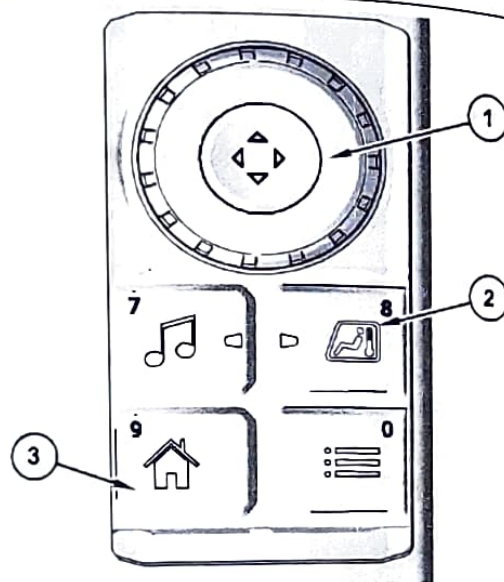

Illustration 146

g06348804

- (1) Jog dial
- (2) Heating and air conditioning button
- (3) Home button

Air conditioning and heating functions are controlled through the monitor. The heating and cooling menu can be directly accessed by pressing button (2) on the right side switch panel. Input selections can be made using jog dial (1) or using the monitor. Home button (3) can be used to return to the main screen.



Illustration 147 g06348808

Press the Air Conditioning and Heating button (2) to go directly to the air conditioner screen.

To navigate to the air conditioner screen from the main screen, press menu button (4).

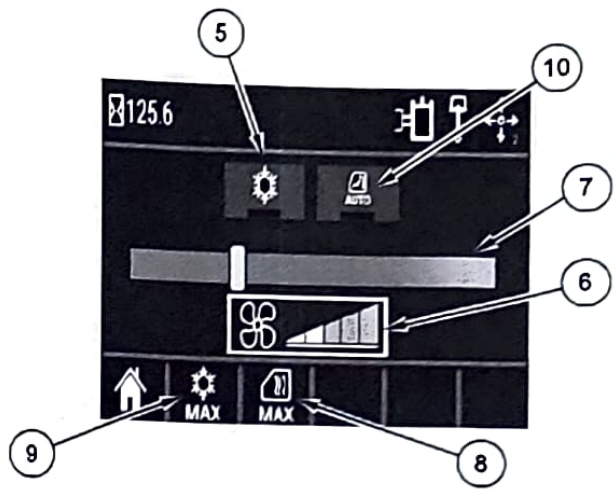

Illustration 149 g06605342

**Air conditioner screen**

- (5) Air Conditioning indicator
- (6) Fan blower speed control
- (7) Temperature control
- (8) Maximum defrost
- (9) Maximum A/C
- (10) Auto temperature control

**Air Conditioning indicator (5)** – Illuminates when the air conditioning system is ON.

**Fan blower speed control (6)** – The blower control is used to increase or decrease the desired blower speed.

**Temperature control (7)** – The temperature control is used to raise or lower the air temperature coming out of the vents.

**Maximum Defrost(8)** – Pressing this button sets the blower fan to max speed, turns the air conditioning on and changes the temperature to the hottest setting. Use this setting to remove steam and frost from the windows.

**Maximum A/C (9)** – Pressing this button sets the blower fan to max speed, turns the air conditioner on and changes the temperature to the coldest setting.

**Auto temperature control (10)** – Illuminates when the automatic temperature control feature is active.

**Automatic Temperature Control**

The control will automatically adjust the air conditioner, heater, and fan control to achieve the desired temperature. The fan can be adjusted manually while in this mode by adjusting the setting using the jog dial, while the system will still control the heater and air conditioning settings.



Illustration 148 g06334491

Access the screen by selecting the "HVAC" box on the display screen. The jog dial is standard on any machine with HVAC or radio since those functions require the jog dial to operate them.



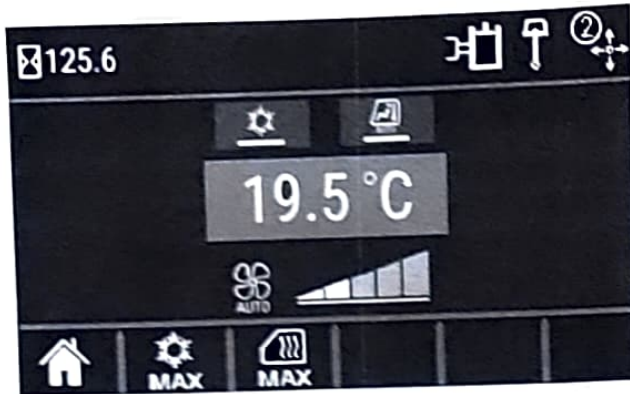

Illustration 150

g06348612

When automatic temperature control is active, the digital temperature setting is displayed.

## Selection Method

Most settings can be made using the display screen or by using the jog dial. Some radio and some air conditioning/heating controls can only be performed using the jog dial. When using the display screen, simply press the button below the icon you want to select. When using the jog dial, rotate the dial to switch to different selections within the screen. Press the jog dial downward to choose a selection.

When using the jog dial to set the temperature or blower speed, rotate the dial clockwise to increase and counter-clockwise to decrease. Press downward on the dial to enter the desired setting. Press downward

## Air Vent Locations

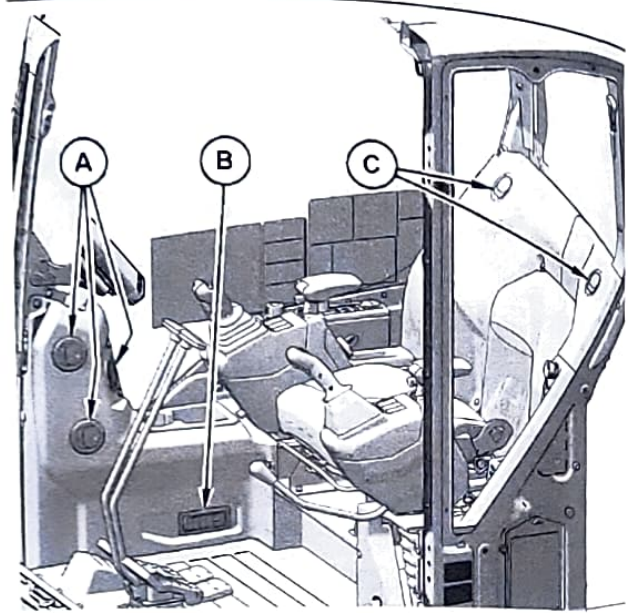

Illustration 151

g06278002

- (A) Front air vents
- (B) Floor air vents
- (C) Rear air vents

Redirect the louvers for air outlets (A), (B), and (C) by hand to the desired direction.

i07526086

## Mirror

SMCS Code: 7319

### **WARNING**

Adjust all mirrors as specified in the Operation and Maintenance Manual. Failure to heed this warning can lead to personal injury or death.

**Note:** Your machine may not be equipped with all the mirrors that are described in this topic.



Illustration 152  
(1) Cab mirror

g06278048

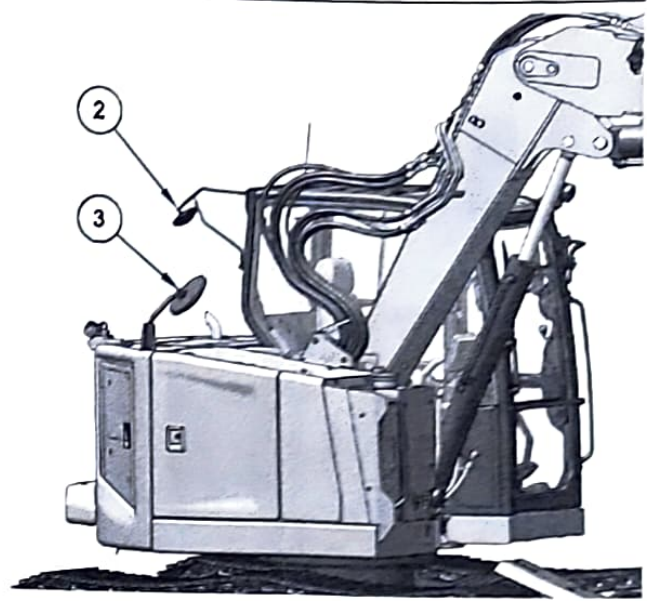

Illustration 154  
(2) Rear mirror  
(3) Right side mirror

g06255286

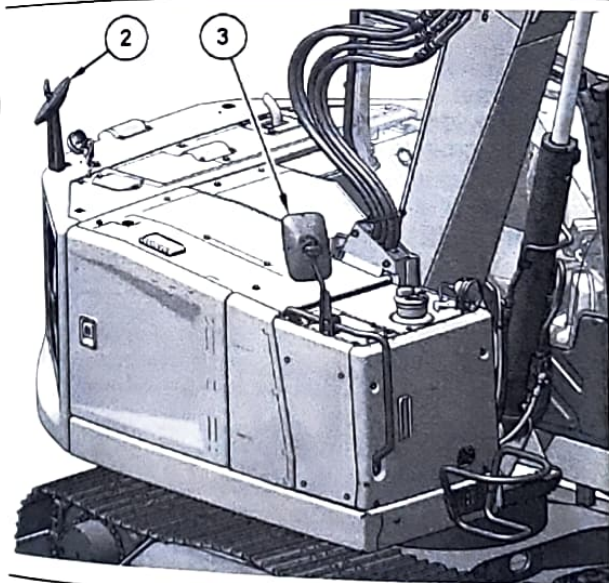

Illustration 153  
(2) Rear mirror  
(3) Right side mirror

g06278056

Mirrors provide additional visibility around your machine. Make sure that the mirrors are in proper working condition and that the mirrors are clean. Adjust all mirrors at the beginning of each work period and adjust the mirrors when you change operators.

Modified machines or machines that have additional equipment or attachments may influence your visibility.

## Mirror Adjustment

- Park the machine on a level surface.
- Lower the work tool to the ground.
- Move the hydraulic lockout control to the LOCKED position. For further details on this procedure, refer to Operation and Maintenance Manual, "Operator Controls".
- Stop the engine.
- Adjust rear view mirrors to provide visibility behind the machine at a maximum distance of 30 m (98 ft) from the rear corners of the machine.



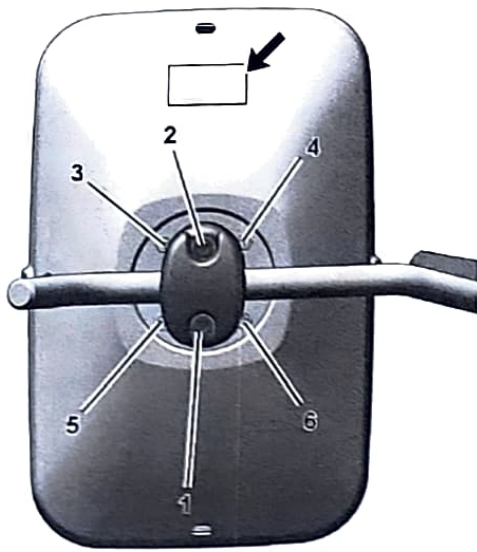

Illustration 155

g06220634

**Tightening sequence**

After adjustment of the mirror angle, make sure that the CAT logo is at the top.

Periodically tightening the mirror mounting bolts may be necessary. If the bolts are loose, tighten the bolts in the sequence shown in Illustration 155. Tighten bolts (1) and (2) to  $11 \pm 2 \text{ N}\cdot\text{m}$  ( $8.1 \pm 1.5 \text{ lb ft}$ ).

Tighten the bolts (3) through (6) to  $2 \pm 0.4 \text{ N}\cdot\text{m}$  ( $1.5 \pm 0.3 \text{ lb ft}$ ).

**Left Side View Mirror on the Cab (1)**

Illustration 156

g06223279

If equipped, adjust the left side view mirror on the cab (1) so the left side of the cab, access door, and rear of left track can be seen from the operator seat. A view of at least 1 m (3.3 ft) from the side of the machine should be seen from the operator seat. Additionally, provide as much visibility to the rear as possible.

**Rear Mirror (2)**

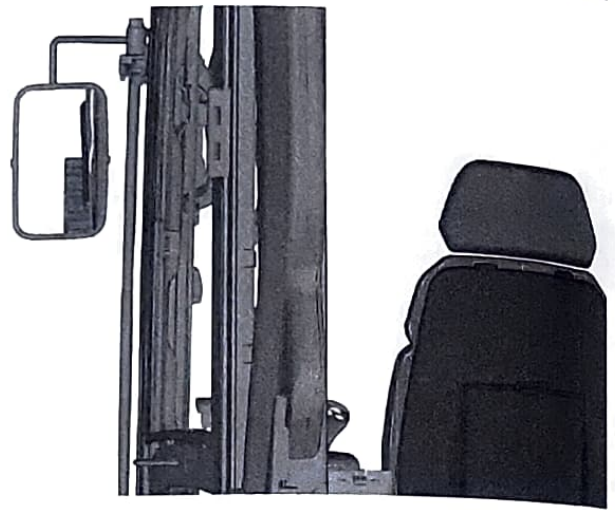
Illustration 157

g06278128

**Counterweight-mounted mirror (If Equipped)**

If equipped, adjust the rear mirror on the counterweight (2) so the right track can be seen from the operator seat. A view of at least 1 m (3.3 ft) from the rear of the machine should be seen from the operator seat.

## Right Side Mirror (3)

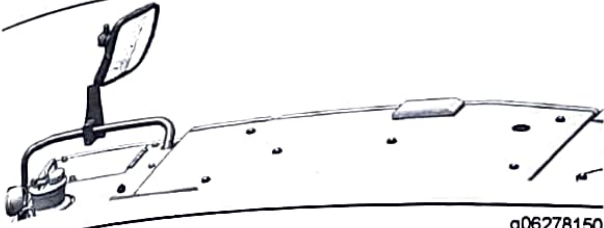

g06278150

Illustration 158

Tank-mounted mirror (If Equipped)

Adjust the tank or right side mirror so a view of at least 1 m (3.3 ft) from the side of the machine can be seen from the operator seat.

i07307697

## Window (Front)

SMCS Code: 7310-FR

To provide full ventilation inside the cab, the upper window and the lower window can be fully opened.

### **⚠ WARNING**

**Crushing Hazard! Stay clear (extremities, clothing) of the window run and of the window. Always open and close the front window using both handles. Always make sure the window locks into the recesses as the window is open and closed. Be careful not to hit the front window with your head as the front window is opened and closed.**

**Stop the engine before opening or closing the front window in order to avoid any unintentional operation or movement of the machine.**

### **⚠ WARNING**

**When opening or closing the windows, be extra careful to prevent any personal injury. The hydraulic lockout control must be in the LOCKED position in order to prevent any possibility of sudden movement of the machine due to inadvertent contact with the hydraulic control(s).**

Do not change the position of the window until the following items have been done:

- Park the machine on a level surface.
- Lower the work tool to the ground.
- Move the hydraulic lockout control to the LOCKED position.
- Stop the engine.

Perform the following procedure to vent the upper window.

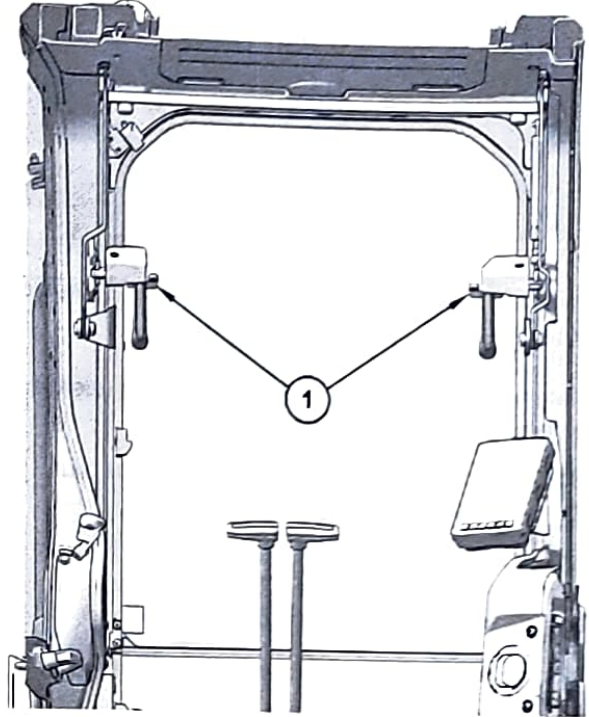

Illustration 159

g06278182

(1) Release lever

1. Release the auto-lock latches by pulling release levers (1) on the window handles.
2. Holding both handles on the window frame, pull the window upward.
3. Hold both handles and move the window into the storage position until the auto-lock latches near the ceiling are engaged.

Perform the following procedure to close the upper window.

1. Release the auto-lock latches by pulling release levers (1) on the window handles.
2. Holding both handles on the window frame, pull the window downward.
3. Hold both handles and move the window into the closed position until the auto-lock latches near the front of the machine engage.

Perform the following procedure to vent the lower window.



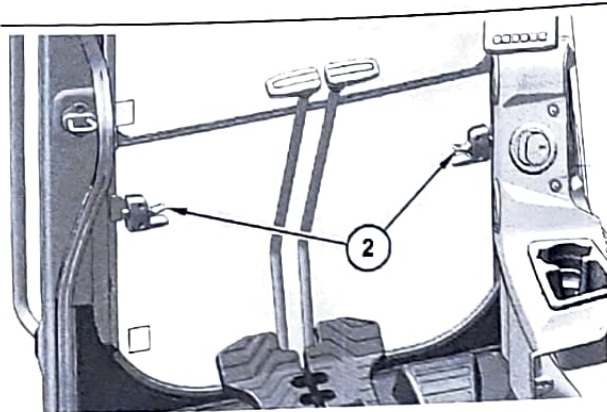

Illustration 160

g06278187

(2) Release lever

1. Release the auto-lock latches by pushing release levers (2) on the window handles.
2. Holding both handles on the window frame, pull the window upward.
3. Hold both handles and move the window into the storage position until the auto-lock latches near the top window are engaged.

**Perform the following procedure to close the upper window.**

1. Release the auto-lock latches by pulling release levers (2) on the window handles.
2. Holding both handles on the window frame, pull the window downward.
3. Hold both handles and move the window into the closed position until the auto-lock latches near the front of the machine engage.

## Cab Door

SMCS Code: 7308

107308015

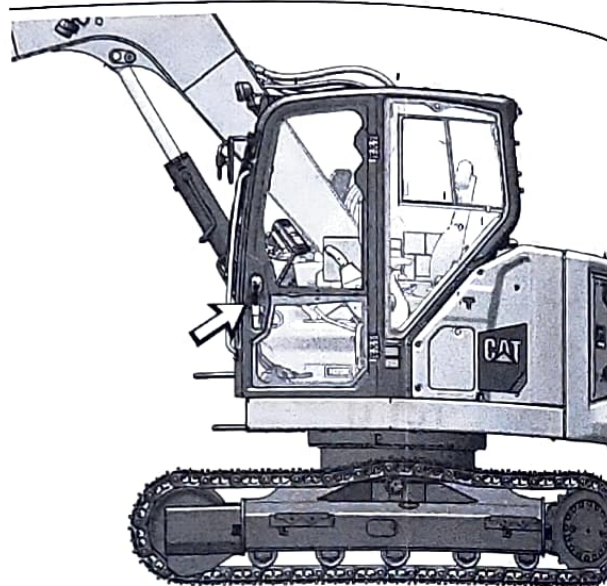

Illustration 161

g06278510

To open the cab door from the outside of the cab, pull outward on the door handle.

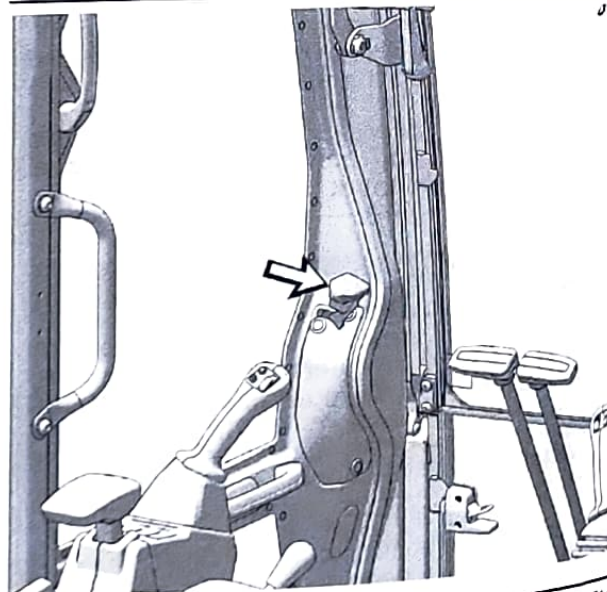

Illustration 162

g06278514

To open the cab door while inside the cab, push forward on the lever for the cab door latch.

For additional ventilation, open the cab door all the way to engage the catch on the exterior wall of the cab.

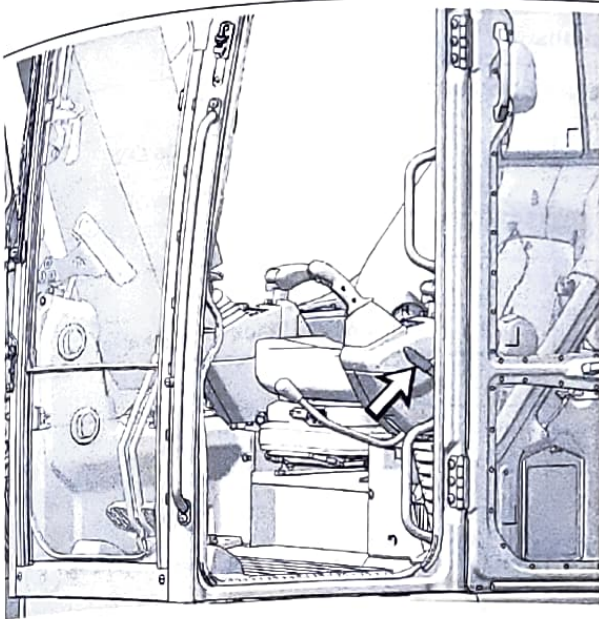

Illustration 163

g06278520

To release the cab door from the catch, pull downward on the cab door release lever.

108259701

## Joystick Controls (One-Button (If Equipped))

SMCS Code: 5705

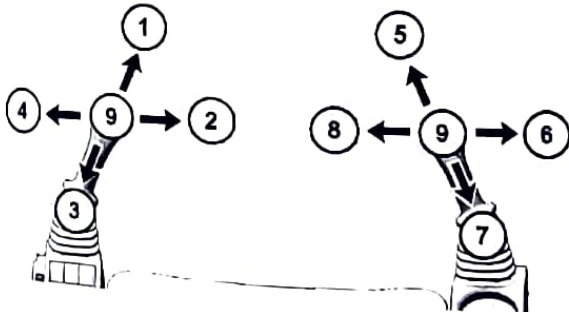

Illustration 164

g06180324

- (1) STICK OUT
- (2) SWING RIGHT
- (3) STICK IN
- (4) SWING LEFT
- (5) BOOM LOWER
- (6) BUCKET DUMP
- (7) BOOM RAISE
- (8) BUCKET CLOSE
- (9) HOLD

When you release the joysticks from any position, the joysticks will return to HOLD position (9). Movement of the upper structure will stop.

Two functions may be performed at the same time by moving a joystick diagonally.

The machine control pattern is initially set at the factory to the excavator pattern system, as shown. The pattern on the left pertains to the left joystick and the pattern on the right pertains to the right joystick.

The machine control pattern can be varied. Refer to Operation and Maintenance Manual, "Joystick Controls Alternate Patterns" for more information.

## Joystick Configurations

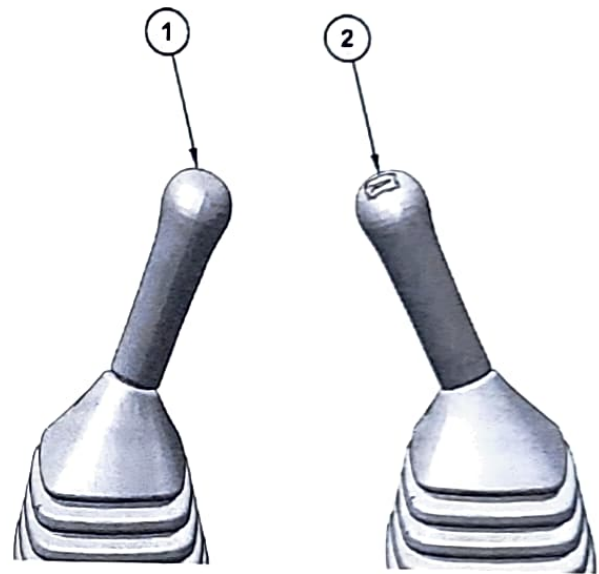

Illustration 165

g06265629

### Slim Joystick Controls

- (1) Left joystick switch
- (2) Right joystick switch



Table 35

Joystick Configurations		
Switch Location	Machine Configuration	
	Joystick Steering Mode OFF	Joystick Steering Mode ON
1	Joystick Steering Mode On/Off	Joystick Steering Mode On/Off
2	Horn	Horn
Left Joystick	Stick / Swing	Travel
Right Joystick	Boom / Bucket	Boom / Bucket / Blade (Configurable)



Illustration 166

g06285635

Machines with this type of joystick require a separate rocker switch for changing travel speed.

This switch is directly behind the right joystick.

**Note:** These machines will have redundant travel speed control on the blade lever for machines with a blade.

### Left Joystick Controls

#### Joystick Steering Mode Button (1)

Push button (1) then press the confirmation button on the monitoring system using the jog dial or display to change the controls of the right joystick and the left joystick to joystick steering mode. The confirmation process must be completed after every key cycle of the machine.

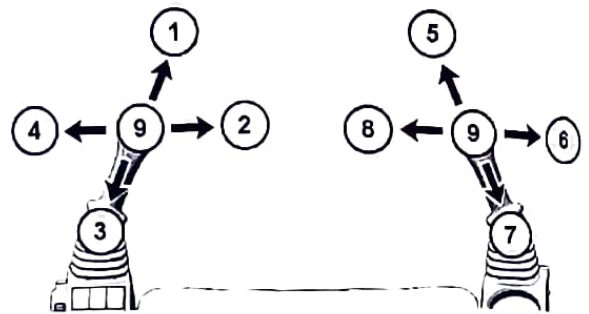

Illustration 167

g06180324

#### Joystick steering pattern A

- (1) TRAVEL FORWARD
- (2) COUNTER-ROTATE CLOCKWISE
- (3) TRAVEL REVERSE
- (4) COUNTER-ROTATE COUNTERCLOCKWISE
- (5) BOOM LOWER
- (6) BUCKET DUMP
- (7) BOOM RAISE
- (8) BUCKET CLOSE
- (9) HOLD

Once activated, the joystick steering light will illuminate as defined in the "Monitor System" section. The left joystick functionality is modified as shown in Illustration 167. This control pattern is identified as joystick steering pattern A.

**Note:** Refer to Table 35 for additional control changes.

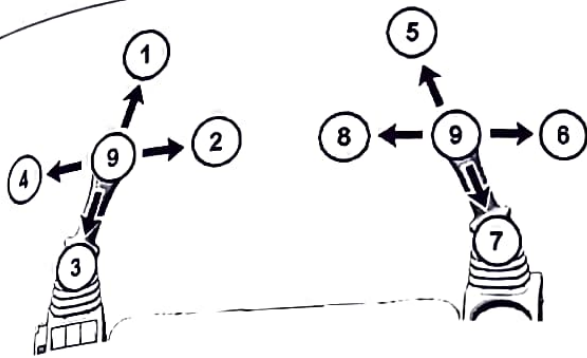

Illustration 168

g06180324

**Joystick steering pattern B**

- (1) TRAVEL FORWARD
- (2) COUNTER-ROTATE CLOCKWISE
- (3) TRAVEL REVERSE
- (4) COUNTER-ROTATE COUNTERCLOCKWISE
- (5) BLADE LOWER
- (6) ANGLE BLADE RIGHT
- (7) BLADE RAISE
- (8) ANGLE BLADE LEFT
- (9) HOLD

While in joystick steering mode, changing an alternate control pattern for the right joystick is possible. This pattern is identified as joystick steering pattern B. pattern. The following image details the control of the machine using blade control on the right joystick lever.

To change the joystick steering pattern between A and B, press the "Menu" button, select "Machine Settings", "Control Mode", "Joystick Steering Pattern". Excavator (pattern A) or Blade (pattern B) can be selected.

**Right Joystick Controls**

**Horn (2)**



Horn (2) – The horn button is on the right side joystick. Depress the horn button to sound the horn. Use the horn before starting the engine, or for alerting or signaling personnel.

i08259706

**Joystick Controls**

SMCS Code: 5705

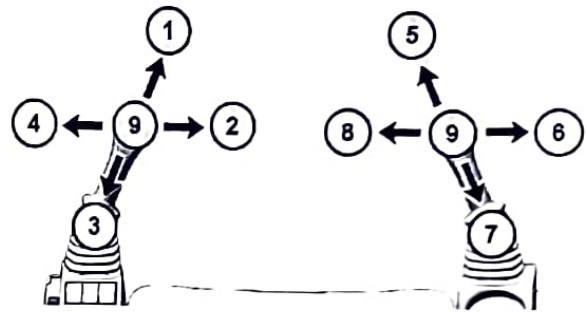

Illustration 169

g06180324

- (1) STICK OUT
- (2) SWING RIGHT
- (3) STICK IN
- (4) SWING LEFT
- (5) BOOM LOWER
- (6) BUCKET DUMP
- (7) BOOM RAISE
- (8) BUCKET CLOSE
- (9) HOLD

When you release the joysticks from any position, the joysticks will return to HOLD position (9). Movement of the upper structure will stop.

Two functions may be performed at the same time by moving a joystick diagonally.

The machine control pattern is initially set at the factory to the excavator pattern system, as shown. The pattern on the left pertains to the left joystick and the pattern on the right pertains to the right joystick.

The machine control pattern can be varied. Refer to Operation and Maintenance Manual, "Joystick Controls Alternate Patterns" for more information.



## Joystick Configurations

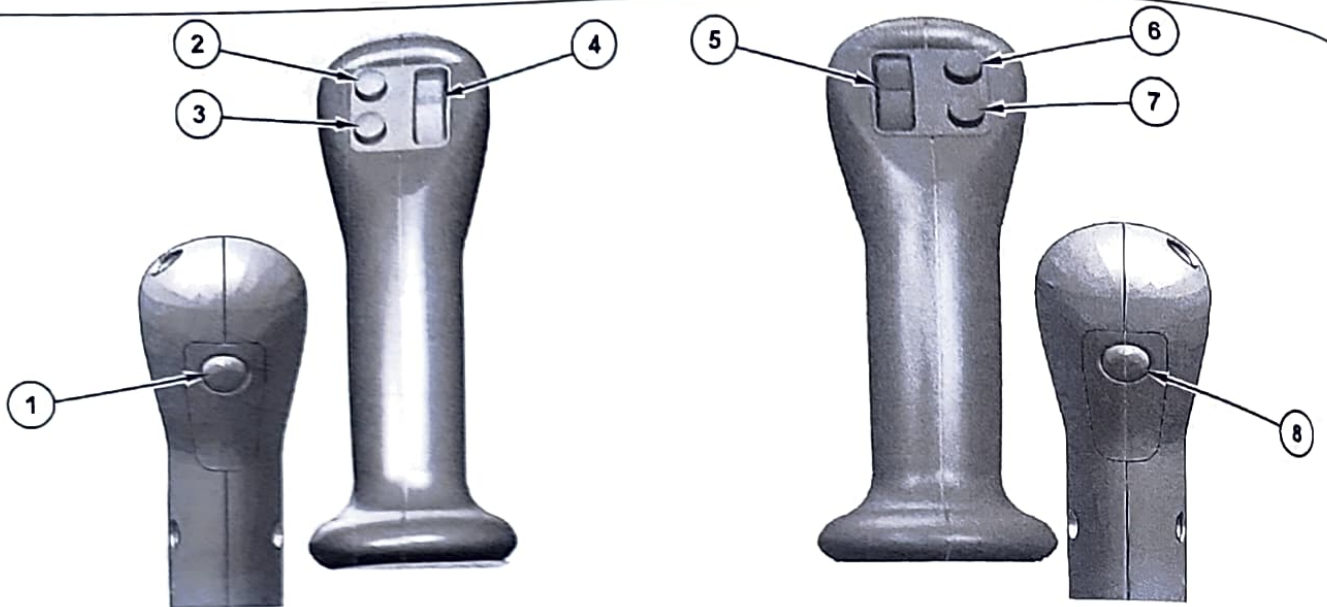

Illustration 170

g06285624

### Vertical Slider Joystick Controls

- (1) Left joystick trigger switch
- (2) Left joystick switch 1
- (3) Left joystick switch 2

- (4) Left joystick thumbwheel
- (5) Right joystick thumbwheel
- (6) Right joystick switch 1

- (7) Right joystick switch 2
- (8) Right joystick trigger switch

Table 36

Joystick Configurations		
Switch Location	Machine Configuration	
	Joystick Steering Mode OFF	Joystick Steering Mode ON
1	Inactive	Cruise Control
2	Boom Swing / Aux 2 Select	House Swing / Aux 2 Select
3	Joystick Steering Mode On/Off	Joystick Steering Mode On/Off
4	Boom Swing / Aux 2 Flow Control	House Swing / Aux 2 Flow Control
5	Aux 1 Flow Control	Aux 1 Flow Control / Stick Control (Configurable)
6	Horn	Horn
7	Travel Speed	Travel Speed
8	Inactive	Inactive / Blade Float / Thumbwheel (5) toggle
Left Joystick	Stick / Swing	Travel
Right Joystick	Boom / Bucket	Boom / Bucket / Blade (Configurable)

### Left Joystick Controls

#### Trigger Switch (1)

Button (1) will only function in joystick steering mode. When in joystick steering mode this button activates cruise control. Cruise control maintains forward or reverse ground speed when the joystick is in the hold position.

Cruise control is available using the Monitor (see "Monitoring System" for details). Cruise control must first be enabled using the monitoring system.

### **WARNING**

**A seat belt should be worn at all times during machine operation to prevent serious injury or death in the event of an accident or machine overturn. Failure to wear a seat belt during machine operation may result in serious injury or death.**

Do not mount a moving machine. Do not dismount a moving machine. Never jump off the machine. Do not carry tools or supplies when you try to mount the machine or when you try to dismount the machine. Use a hand line to pull equipment onto the platform. Do not use any controls as handholds when you enter the operator compartment or when you exit the operator compartment.

Cruise control is disabled by any of the following:

- moving the left joystick forward or reverse after placing the joystick in the hold position.
- pressing button (1).
- moving the travel pedals.
- pressing button (3).
- hydraulic lockout control lever is raised to the lockout position.

#### Boom Swing / 2nd Auxilliary Button (2)

Button (2) will determine which function thumb wheel (4) controls.

The default setting of thumb wheel (4) is boom swing function (if equipped).

#### Joystick Steering Mode Button (3)

Push button (3) to activate joystick steering mode, then press the confirmation button on the monitoring system using the jog dial or the display. The confirmation process must be completed after every key cycle of the machine.

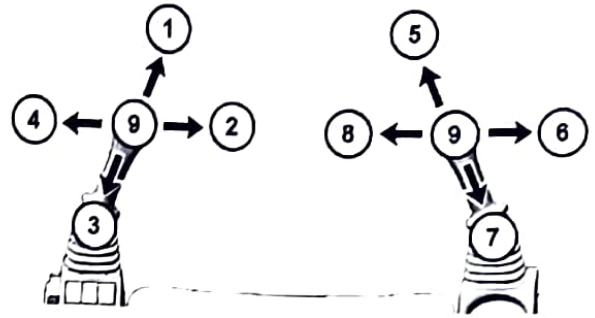

Illustration 171

g06180324

#### Joystick steering pattern A

- (1) TRAVEL FORWARD
- (2) COUNTER-ROTATE CLOCKWISE
- (3) TRAVEL REVERSE
- (4) COUNTER-ROTATE COUNTERCLOCKWISE
- (5) BOOM LOWER
- (6) BUCKET DUMP
- (7) BOOM RAISE
- (8) BUCKET CLOSE
- (9) HOLD

Once activated, the joystick steering light will illuminate as defined in the "Monitor System" section. The left joystick functionality is modified as shown in Illustration 171. This control pattern is identified as joystick steering pattern A.

**Note:** Refer to Table 36 for additional control changes.

In joystick steering mode, machine swing is available on the left thumb roller in place of boom swing (if equipped). Machine swing and aux 2 (if equipped) can toggle function control on the left thumbwheel while in joystick steering mode.



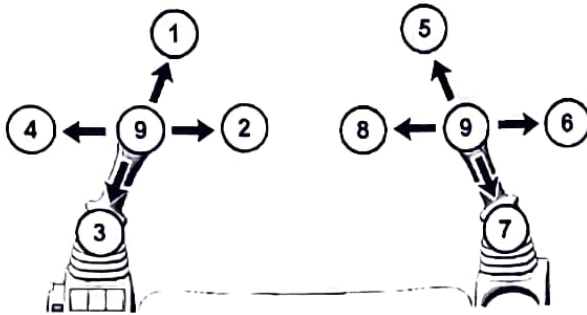

Illustration 172

g06180324

**Joystick steering pattern B**

- (1) TRAVEL FORWARD
- (2) COUNTER-ROTATE CLOCKWISE
- (3) TRAVEL REVERSE
- (4) COUNTER-ROTATE COUNTERCLOCKWISE
- (5) BLADE LOWER
- (6) BLADE TILT CLOCKWISE
- (7) BLADE RAISE
- (8) BLADE TILT COUNTERCLOCKWISE
- (9) HOLD

While in joystick steering mode, changing an alternate control pattern for the right joystick is possible. This pattern is identified as joystick steering pattern B. The following image details the control of the machine using blade control on the right joystick lever.

To change the joystick steering pattern between A and B, press the "Menu" button, select "Machine Settings", "Control Mode", "Joystick Steering Pattern". Excavator (pattern A) or Blade (pattern B) can be selected.

While in joystick steering mode with pattern B, the blade can be placed into float by moving the right joystick FORWARD and then pressing the right joystick trigger switch (8) while the right joystick is still FORWARD. The blade will remain in float after returning the right joystick to the HOLD position. Pressing the right joystick trigger switch again, moving the right joystick out of HOLD or moving the dozer blade lever out of HOLD will disable blade float.

**Advanced Joystick Steering Mode:** An advanced control pattern is available in joystick steering mode using the service mode of the display (see "Monitoring System – Thumbwheel Mode" for setup details). When Thumbwheel Mode is set to enabled and Joystick Steering Pattern A is selected, the trigger on the right joystick can allow for toggling between aux 1 and stick function on the right joystick thumbwheel.

**Boom Swing / 2nd Auxiliary Flow Control (4)**

If thumb wheel (4) is changed to second auxiliary control, the thumb wheel is used to operate work tools such as a grapple. Refer to Operation and Maintenance Manual, "Work Tool Control" for more information.

If thumb wheel (4) is changed to boom swing function, refer to the information below.

The boom swing control is used to swing the boom to the right or to the left.



**Swing Left – Pull downward on the left thumbwheel to swing the boom to the LEFT.**



**Swing Right – Push upward on the left thumbwheel to swing the boom to the RIGHT.**

**Note:** Operate the boom swing thumbwheel carefully until you become familiar with how boom swing reacts to the controls.

**Right Joystick Controls****Primary Auxiliary Control (5)**

The primary auxiliary control thumb wheel is used to control the work tools. For more information on the auxiliary controls, refer to Operation and Maintenance Manual, "Work Tool Control".

This thumbwheel can be toggled to activate the stick using button (8) while in joystick steering mode if right joystick is configured to Boom/Bucket by using advanced settings in the monitoring system.

**Horn (6)**

**Horn (6) – The horn button is on the right side joystick. Depress the horn button to sound the horn. Use the horn before starting the engine, or for alerting or signaling personnel.**

**Travel Speed Control (7)**

Depress the travel speed button to change between low and high travel speed. When high travel speed is selected, the high speed indicator will illuminate on the monitor.

Always travel at slow speeds on slopes and rough ground.

i08330602

## Work Tool Control

SMCS Code: 6700

Auxiliary lines are equipped with coupler assemblies. Wipe all coupler assemblies before you connect the work tools. The auxiliary lines must be relieved of pressure in order to connect the coupler assemblies to the work tool. Relieve the pressure in the auxiliary hydraulic lines by performing the following steps:

1. Operate the machine to charge the accumulator.
2. Lower implements to the ground.
3. Turn the engine off and turn the key switch to the ON position without starting the engine.
4. Ensure the Hydraulic Lockout control is in the UNLOCKED position to provide function to the hydraulic circuits.
5. Actuate the auxiliary circuit in both directions several times.

**Note:** Pressure can build up in the auxiliary lines if the attachment is not coupled/uncoupled immediately after the pressure has been released.

### One-Way Flow

The following information pertains to work tools that require hydraulic oil flow in one direction. Hydraulic hammers are an example of work tools that require hydraulic oil flow in one direction.

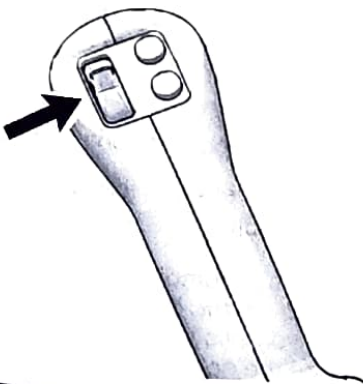

Illustration 173

Right joystick thumb wheel

g06287026

**Variable Speed** – Move the thumb wheel upward to activate the work tool. Move the thumb wheel further to increase the speed of the work tool.

### Hammer Control

**Hydraulic Hammer ON** – Push the right joystick switch upward to activate the hydraulic hammer.

**Hydraulic Hammer OFF** – Release the right joystick switch to deactivate the hydraulic hammer.

### Two-Way Flow

The following information pertains to work tools that require hydraulic oil flow in two directions. These work tools can also be equipped with a rotate circuit. Hydraulic shears, pulverizers, crushers, and grapples are examples of work tools that require hydraulic oil flow in two directions.

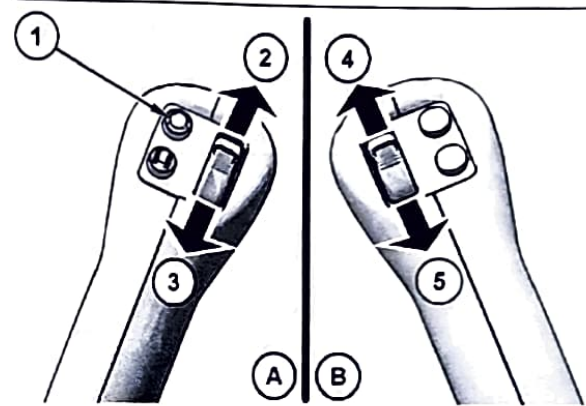

Illustration 174

g06287028

(A) Left joystick  
(B) Right joystick

### Primary Auxiliary Hydraulic Circuit (AUX 1)

**Variable Speed** – Move the thumb wheel in the direction of desired flow to activate the work tool. Move thumb wheel upward (4): Aux 1B. Move thumb wheel downward (5): Aux 1A. Move the thumb wheel further to increase the speed of the work tool. Release the thumb wheel to stop the work tool.

### Secondary Auxiliary Hydraulic Circuit (AUX 2)

**Variable Speed** – Press button (1) once to activate the secondary auxiliary flow control. Press button (1) again to deactivate the secondary auxiliary flow control to engage boom swing (default if equipped). The secondary auxiliary flow control must be activated to operate the circuit.



Move the thumb wheel in the direction of desired flow to activate the work tool. Move thumb wheel upward (2) : Aux 2B. Move thumb wheel downward (3) : Aux 2A. Move the thumb wheel further to increase the speed of the work tool. Release the thumb wheel to stop the work tool.

## Primary Auxiliary Hydraulic Circuit (AUX 1)

### WARNING

Unexpected operation of the auxiliary control circuit can cause injury or death.

A RAISED hydraulic lock lever does not mean that the auxiliary control function is locked out.

In order to prevent unexpected operation of the auxiliary control circuit, make sure that the foot is not placed on or near the work tool control pedal.

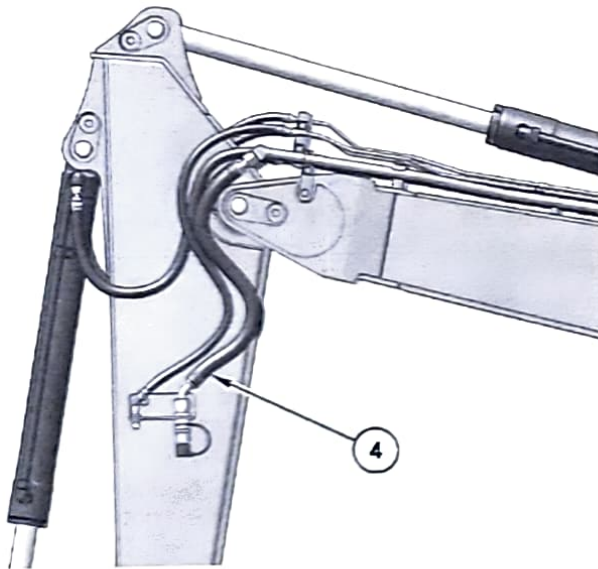

Illustration 175  
Left side view of stick  
(4) Aux 1B

g06338787

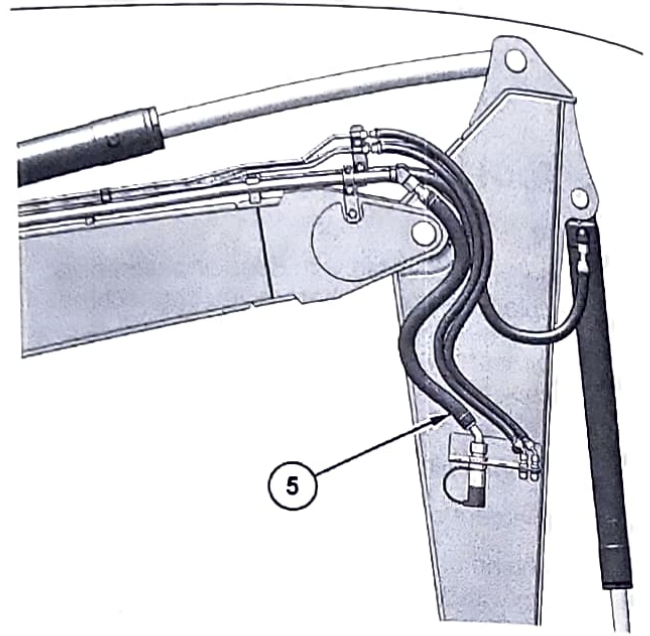

Illustration 176

Right side view of stick  
(5) Aux 1A

g06338784

There are two primary auxiliary lines that are routed to the stick.

Line (4) is on the left side of the stick and is an oil feed line. Line (5) is on the right side of the stick and is an oil return line.

The primary auxiliary lines can be equipped with coupler assemblies. Wipe all coupler assemblies before you connect the work tools.

The primary auxiliary lines must be relieved of pressure to connect the coupler assemblies to the work tool. Relieve the pressure in the primary auxiliary hydraulic lines by performing the following steps:

1. Turn the engine start switch key to the ON position with the engine OFF.
2. Lower the hydraulic lockout control lever.
3. Move the control levers and thumb wheels in both directions repeatedly.

**Note:** The hydraulic accumulator must have pressure in order to relieve a circuit. If needed, start engine and engage the hydraulic lockout control lever for 5 seconds to charge the accumulator. After the accumulator has been pressurized, repeat Steps 1 through 3.

4. Uncouple the attachment immediately after the pressure has been released.

**Note:** Pressure can build up in the primary auxiliary lines if the attachment is not coupled or uncoupled immediately after the pressure has been released.

### Secondary Auxiliary Hydraulic Circuit (AUX 2) (If Equipped)

**WARNING**  
Unexpected operation of the secondary auxiliary control circuit can cause injury or death.

In order to prevent unexpected operation of the secondary auxiliary control circuit, make sure that the thumb is not placed on or near the switch on the left joystick.

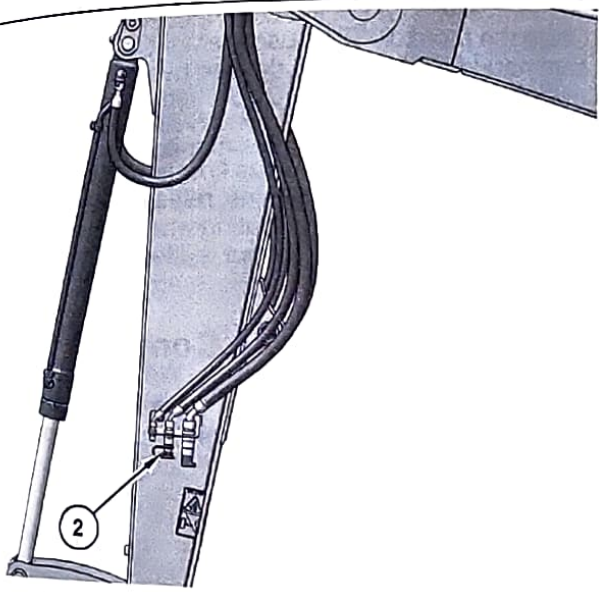

Illustration 177  
Left side view of stick  
(2) Aux 2B

g06338790

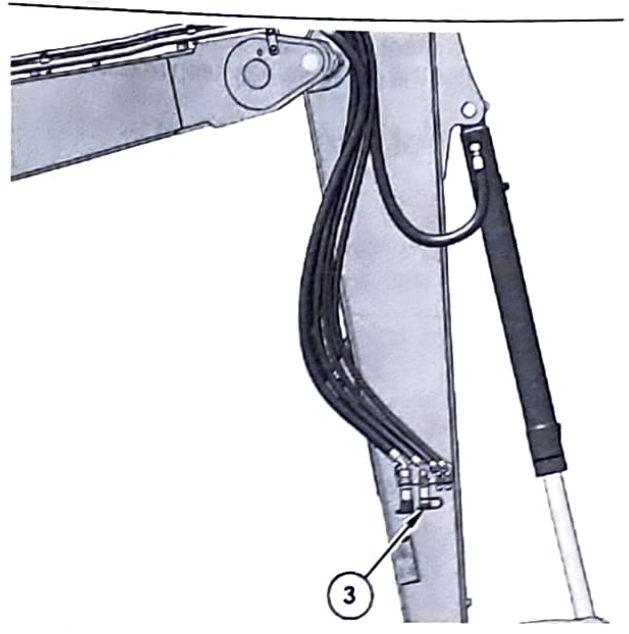

Illustration 178  
Right side view of stick  
(3) Aux 2A

g06338800

There are two secondary auxiliary lines that are routed to the stick.

Line (2) is on the left side of the stick and is an oil feed line. Line (3) is on the right side of the stick and is an oil return line.

The secondary auxiliary lines are equipped with coupler assemblies. Wipe all coupler assemblies before you connect the work tools.

The secondary auxiliary lines must be relieved of pressure to connect the coupler assemblies to the work tool. Relieve the pressure in the secondary auxiliary hydraulic lines by performing the following steps:

1. Turn the engine start switch key to the ON position with the engine OFF.
2. Using button (1) on the joystick, change the mode from "Boom Swing" to "Aux 2".
3. Lower the hydraulic lockout control lever.
4. Move the control levers and thumb wheels in both directions repeatedly.

**Note:** The hydraulic accumulator must have pressure in order to relieve a circuit. If needed, start engine and engage the hydraulic lockout control lever for 5 seconds to charge the accumulator. After the accumulator has been pressurized, repeat Steps 1 through 4.

5. Uncouple the attachment immediately after the pressure has been released.



**Note:** Pressure can build up in the primary auxiliary lines if the attachment is not coupled or uncoupled immediately after the pressure has been released.

## Auxiliary Tool Case Drain (if equipped)

The case drain is necessary for certain tools with hydraulic motors such as mulchers and flail mowers.

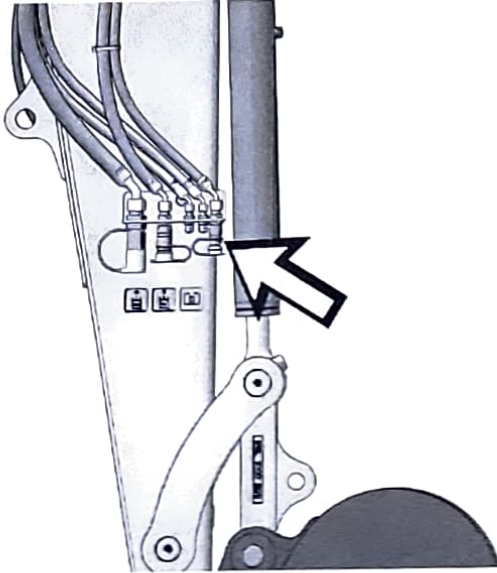

Illustration 179

g06348127

Case drain coupling on the stick

Wipe the quick connectors clean before attaching the case drain to the machine.

## Continuous Flow

**Note:** The continuous flow feature must first be enabled in the monitor. Refer to Operation and Maintenance Manual, "Monitoring System" for additional information.

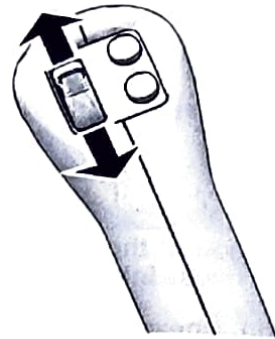

Illustration 180

g06287030

The operator controls the hydraulic flow rate with the thumbwheel on the right-hand joystick. To set continuous flow, first set the continuous flow feature to ON in the monitor. Then use the right thumb wheel to command Aux 1 until the desired hydraulic flow rate is achieved. Hold the thumb wheel at the desired command for 2.5 seconds. After 2.5 seconds, the continuous flow indicator on the monitor will turn green indicating that continuous flow is ACTIVE. Once the continuous flow begins, release the switch. Continuous flow will stop operating when the switch is moved or the hydraulic lockout is lifted or when the machine is turned off.

## Work Tool Flow Mode Control



**One-Way Flow** – Move work tool flow control lever to this position when one-way flow is required.



**Two-Way Flow** – Move work tool flow control lever to this position when two-way flow is required.

### One-Way Flow

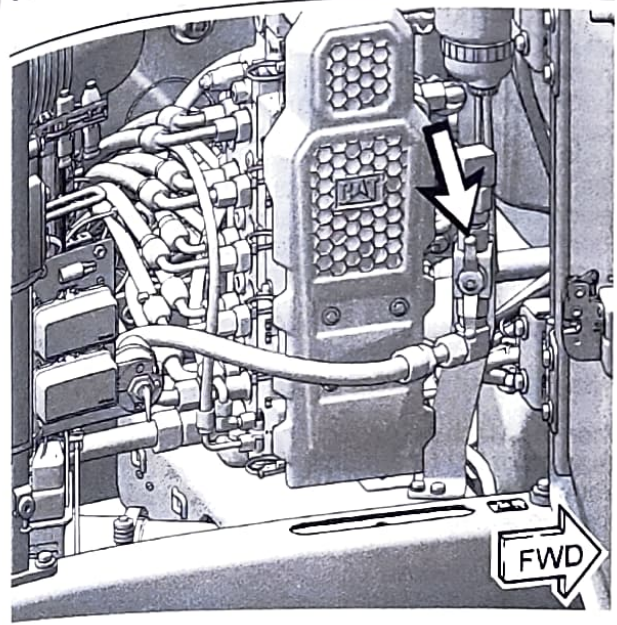

Illustration 181 g06349995

#### Valve position for one-way flow

The flow control manual valve is located next to the battery and can be accessed using the right rear door.

### Two-Way Flow

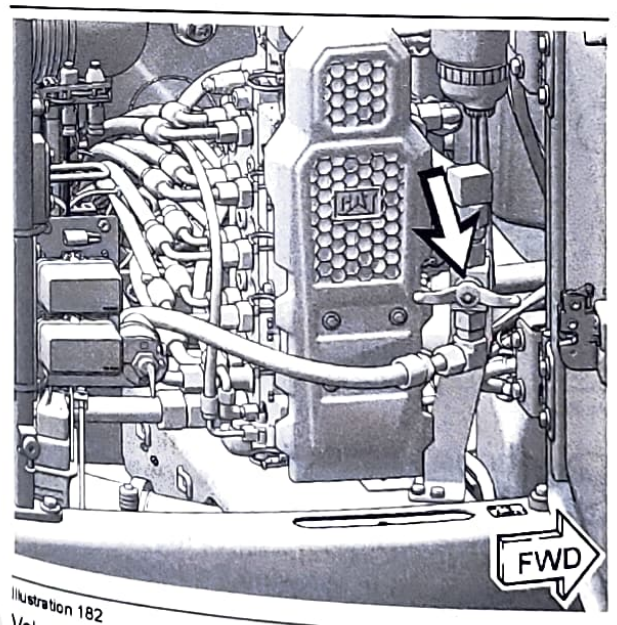

Illustration 182 g06349992

#### Valve position for two-way flow

The flow control manual valve is located next to the battery and can be accessed using the right rear door.

### Adjustable Primary Auxiliary Valves

This feature enables the ability to adjust pressures allowing for customized and improved performance of work tools.

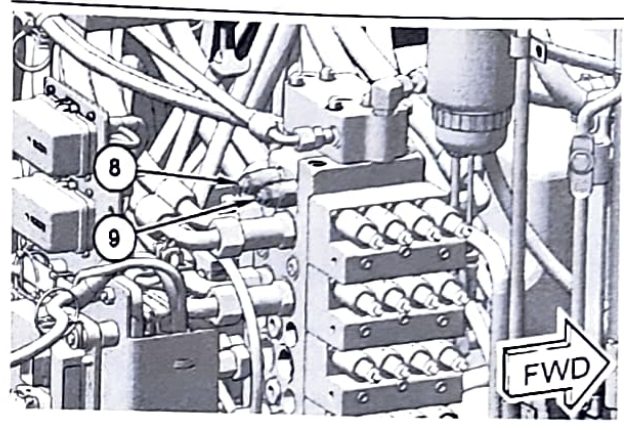

Illustration 183 g06288004

- (8) Adjustable Relief Valve for Aux 1B
- (9) Adjustable Relief Valve for Aux 1A

The adjustable relief valves are on the main control valve. Open the right side access door to gain access to the valve.

### Auxiliary Control Pedal (AUX 1) (Two-Way Flow) (If Equipped)

**⚠ WARNING**

Unintended operation of the Auxiliary Control pedal can cause injury or death. A RAISED hydraulic lock lever does not mean that the auxiliary line is locked out.

To Prevent unintended activation of the Auxiliary Control pedal while traveling or whenever the auxiliary line is not being used, make sure the foot is not placed on or near the Auxiliary Control pedal.

**Note:** Operate the Auxiliary Control pedal carefully until you become familiar with how "AUX 1" reacts to the controls.

The right Auxiliary Control pedal controls the two-way flow auxiliary line circuit (AUX 1).



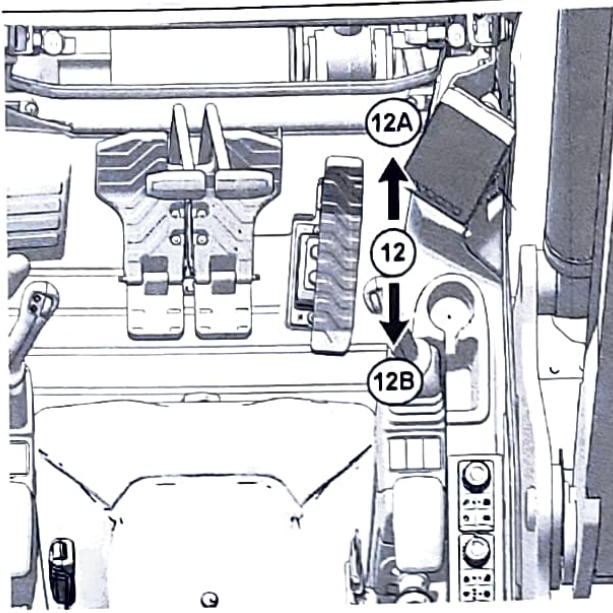

Illustration 184

g06338832

To pressurize the line that is connected to the left-hand side of the stick, apply pressure to the front of the pedal.

To pressurize the line that is connected to the right-hand side of the stick, apply pressure to the back of the pedal.

i08376936

## Joystick Controls Alternate Patterns

SMCS Code: 5059; 5137

**WARNING**

Check if control pattern 1 (Standard) or control pattern 2 (Alternate) is selected before operating the machine.

Refer to Operation and Maintenance Manual.

Failure to understand control functions could result in injury or death.

Note: Joystick Controls Alternate Patterns are not available when the joystick steering mode is ON.

To access the pattern changer screen, press the "Menu" button, select "Machine Settings", "Control Mode", then "Pattern Changer".

The Joystick-Mapping Installation Status configuration must be set to installed in Cat Electronic Technician (ET) and the Pattern Changer must be configured as Enabled in the display for the Pattern Changer to be available. Then modifying the Machine Application Configuration and the Joystick Mapping Group Selection in Cat ET will impact the available patterns as summarized below.

When the Machine Application Configuration is set to Standard and the Joystick Mapping Group Selection is configured as Two Way, the following pattern changer selections are available:

- Excavator
- Backhoe

When the Machine Application Configuration is set to Standard or ISJ Common and the Joystick Mapping Group Selection is configured as Four Way, the following pattern changer selections are available:

- "ISO" (Excavator)
- "SCM"
- "MHI"
- "KOB"

## Backhoe Joystick Pattern

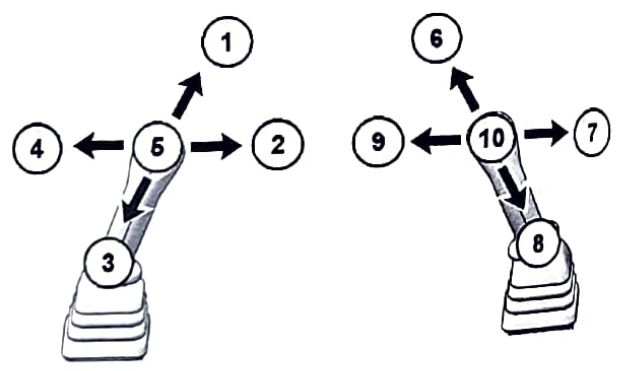





Illustration 185

g06349078

-  **BOOM LOWER (1)** – Move the joystick to this position to lower the boom.
-  **SWING RIGHT (2)** – Move the joystick to this position to swing the upper structure to the right.
-  **BOOM RAISE (3)** – Move the joystick to this position to raise the boom.
-  **SWING LEFT (4)** – Move the joystick to this position to swing the upper structure to the left.

**HOLD (5)** – When you release the joystick from any position, the joystick will return to the HOLD position. Movement of the structure will stop.

**STICK OUT (6)** – Move the joystick to this position to move the stick outward.

**BUCKET DUMP (7)** – Move the joystick to this position to dump the bucket or the work tool.

**STICK IN (8)** – Move the joystick to this position to move the stick inward.

**BUCKET CLOSE (9)** – Move the joystick to this position to close the bucket or the work tool.

**HOLD (10)** – When you release the joystick from any position, the joystick will return to the HOLD position. Movement of the structure will stop.

Two functions may be performed at the same time by moving the joysticks diagonally.

### SCM Joystick Pattern

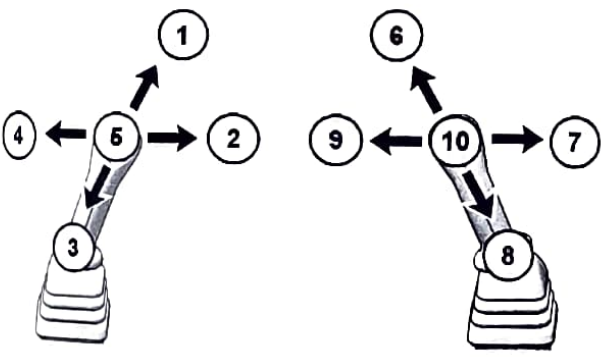

Illustration 186 g06349078

**SWING RIGHT (1)** – Move the joystick to this position to swing the upper structure to the right.

**STICK IN (2)** – Move the joystick to this position to move the stick inward.

**SWING LEFT (3)** – Move the joystick to this position to swing the upper structure to the left.

**STICK OUT (4)** – Move the joystick to this position to move the stick outward.

**HOLD (5)** – When you release the joystick from any position, the joystick will return to the HOLD position. Movement of the structure will stop.

**BOOM LOWER (6)** – Move the joystick to this position to lower the boom.

**BUCKET DUMP (7)** – Move the joystick to this position to dump the bucket or the work tool.

**BOOM RAISE (8)** – Move the joystick to this position to raise the boom.

**BUCKET CLOSE (9)** – Move the joystick to this position to close the bucket or the work tool.

**HOLD (10)** – When you release the joystick from any position, the joystick will return to the HOLD position. Movement of the structure will stop.

Two functions may be performed at the same time by moving the joysticks diagonally.

### MHI (Mitsubishi) Joystick Pattern

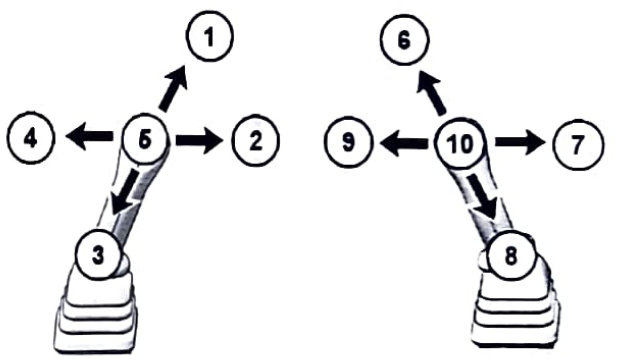

Illustration 187 g06349078

**BOOM LOWER (1)** – Move the joystick to this position to lower the boom.

**BUCKET CLOSE (2)** – Move the joystick to this position to close the bucket or the work tool.

**BOOM RAISE (3)** – Move the joystick to this position to raise the boom.

**BUCKET DUMP (4)** – Move the joystick to this position to dump the bucket or the work tool.

**HOLD (5)** – When you release the joystick from any position, the joystick will return to the HOLD position. Movement of the structure will stop.





**STICK IN (6)** – Move the joystick to this position to move the stick inward.



**SWING RIGHT (7)** – Move the joystick to this position to swing the upper structure to the right.



**STICK OUT (8)** – Move the joystick to this position to move the stick outward.



**SWING LEFT (9)** – Move the joystick to this position to swing the upper structure to the left.

**HOLD (10)** – When you release the joystick from any position, the joystick will return to the HOLD position. Movement of the structure will stop.

Two functions may be performed at the same time by moving the joysticks diagonally.



**SWING RIGHT (7)** – Move the joystick to this position to swing the upper structure to the right.



**STICK IN (8)** – Move the joystick to this position to move the stick inward.



**SWING LEFT (9)** – Move the joystick to this position to swing the upper structure to the left.

**HOLD (10)** – When you release the joystick from any position, the joystick will return to the HOLD position. Movement of the structure will stop.

Two functions may be performed at the same time by moving the joysticks diagonally.

## KOB (Shin-Ko) Joystick Pattern

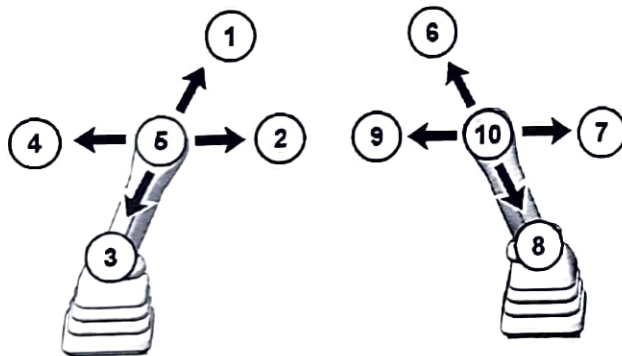

Illustration 188

g06349078



**BOOM LOWER (1)** – Move the joystick to this position to lower the boom.



**BUCKET CLOSE (2)** – Move the joystick to this position to close the bucket or the work tool.



**BOOM RAISE (3)** – Move the joystick to this position to raise the boom.



**BUCKET DUMP (4)** – Move the joystick to this position to dump the bucket or the work tool.

**HOLD (5)** – When you release the joystick from any position, the joystick will return to the HOLD position. Movement of the structure will stop.



**STICK OUT (6)** – Move the joystick to this position to move the stick outward.

# Engine Starting

108200507

## Engine Starting

SMCS Code: 1000; 1090; 1456; 7000

### WARNING

Do not spray ether into engine when using thermal starting aid to start engine. Personal injury and machine damage could result. Follow procedure in the Operation and Maintenance Manual.

### NOTICE

The engine start switch must be in the ON position and the engine must be running in order to maintain electrical functions and hydraulic functions. This procedure must be followed in order to prevent serious machine damage.

1. Move the hydraulic lockout control (lever) to the LOCKED position.
2. Move the joysticks to the HOLD position.
3. Turn the engine start switch to the ON position. During cold weather, leave the engine start switch in the ON position until the glow plug lamp on the display turns off to preheat the glow plugs.

**Note:** It is not necessary to preheat the glow plugs on a warm engine.

4. All the indicators on the monitor panel should be activated and the action alarm should sound for approximately 2.5 seconds. If any of the indicators are not activated or if the action alarm does not sound, check the electrical system. Make any necessary repairs before you start the engine.

**Note:** For more information on the monitoring system, refer to Operation and Maintenance Manual, Monitoring System.

If any fluid levels are too low, add the corresponding fluid to the specified level. Add the fluid before you start the engine.

5. Before you start the engine, check for the presence of bystanders or maintenance personnel. Ensure that all personnel are clear of the machine. Briefly sound the horn before you start the engine.

### NOTICE

If the engine fails to start after 10 seconds, disengage the starter. Wait 30 seconds before cranking again.

Do not crank the engine for more than 20 seconds. Cranking the engine for more than 20 seconds may cause damage to the engine and/or hydraulic system.

6. Turn the engine start switch to the START position.
7. Release the engine start switch key after the engine starts.
8. If the engine does not start, turn the key to the OFF position. Repeat step 6 and step 7.

108200510

## Engine and Machine Warm-Up

SMCS Code: 1000; 7000

### NOTICE

Always run the engine at low idle for at least ten minutes before performing any other operations in cold conditions or each time the engine oil and oil filter are changed in order to protect your engine and hydraulic components.

### NOTICE

Depending on the ambient temperature, in order to prevent the machine operation with high speed without sufficient lubrication at the turbo bearing, the engine speed may be set to low speed and the hydraulic power minimized for a pre-determined time after the engine starts. Refer to turbo protection feature.

To accelerate engine and hydraulic warmup in cold ambient temperature or high altitude for an extended time, the engine may automatically change speeds when the machine is stationary and the implements are LOCKED. During this warmup the hydraulic system will activate a warmup process that will cause hydraulic oil to flow through the valve to heat the hydraulic system. All accelerated warmup processes are automatic and will disable when the machine has warmed or the operator places the implements in the UNLOCKED position.



## Hydraulic System

### WARNING

When you cycle the machine controls, the machine can move suddenly. Contact between the machine and external objects or ground personnel can result in serious injury or death. Before you cycle the machine controls, the machine should be located in an unobstructed, hazard-free work area that is away from external objects and ground personnel.

1. Make sure that the area is clear of personnel and equipment.

**Note:** The hydraulic lockout control must be in the UNLOCKED position before the hydraulic controls will function.

2. Allow the engine to warmup at low idle for at least 5 minutes.

**Note:** Leave the implements LOCKED during this warmup process.

When you idle the machine for warmup, observe the following recommendations:

- If the temperature is greater than 0°C (32°F), warm up the engine for approximately 15 minutes.
- If the temperature is less than 0°C (32°F), warm up the engine for approximately 30 minutes.
- If the temperature is less than -18°C (0°F) or if hydraulic functions are sluggish, additional time may be required.

### NOTICE

The hydraulic oil temperature should be higher than 25 °C (77 °F) before performing work with the machine. Make sure that the warm-up procedure is performed.

If the hydraulic oil temperature is less than 25 °C (77 °F) and the machine is operated abruptly, serious damage to the hydraulic components may occur.

**Note:** The recommended operating temperature of the hydraulic fluid for this machine is 55 °C (131 °F).

3. To warmup the hydraulic oil, turn the engine speed dial to the medium engine speed.
4. Run the engine for approximately 5 minutes and continuously cycle the stick from fully extended to fully retracted at maximum command.

5. Turn the engine speed dial to the maximum engine speed and repeat Step 4.
6. Cycle all controls to circulate warm oil through all hydraulic cylinders and all hydraulic lines, and through the swing motor and travel motors.
7. Observe the gauges and the indicators frequently during the operation.

## Turbo Protection



**Turbo Protection Power Derate** – After an engine start, the engine speed will be set to low speed and the hydraulic power limited for a time period. To protect the turbo, the engine speed may be slow to respond while the engine warms (maximum time to engine speed changes is 5 minutes). After the turbo bearing lubrication is sufficient, the engine speed goes to the setting dial speed.

# Operation

i08484651

## Operation Information

SMCS Code: 7000

**Note: Operating Temperature Range for the Machine** The machine must function satisfactorily in the anticipated ambient temperature limits that are encountered during operation. The standard machine configuration is intended for use within an ambient temperature range of -18 °C (0 °F) to 43 °C (109 °F). Special configurations for different ambient temperatures may be available. Consult your Cat® dealer for additional information on special configurations of your machine.

Make sure that no personnel are on the machine or near the machine to prevent any personal injury. Keep the machine under control always to prevent injury.

Sound the horn and allow adequate time for bystanders to clear the area before moving the machine into a restricted visibility area. Follow local practices for your machine application. For more information refer to Operation and Maintenance Manual, "Restricted Visibility".

Reduce the engine speed when you maneuver the machine in tight quarters and when you drive over an incline.

Select the necessary travel speed range before you drive downgrade. Do not change the travel speed range while you drive downhill.

Use the same travel speed on a downgrade and on an upgrade.

When you travel for any distance, keep the stick inward and carry the boom in a low position.

When you drive up a steep grade, keep the boom as close to the ground as possible.

When you travel uphill or you travel downhill, keep the boom on the uphill side of the machine.

1. Adjust the operator seat. Refer to Operation and Maintenance Manual, "Seat" for more information.

2. Fasten the seat belt. Refer to Operation and Maintenance Manual, "Seat Belt" for more information.

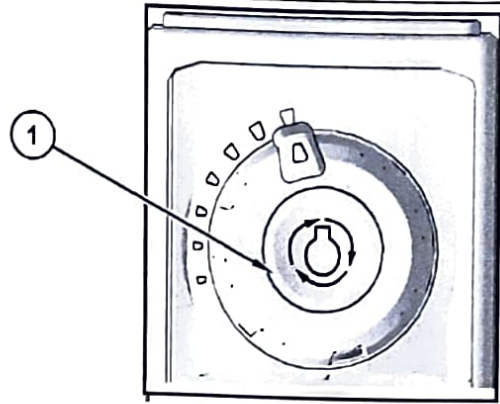

Illustration 189

g06685022

(1) Engine speed dial

3. Turn the engine speed dial (1) to the desired operating range. Refer to Operation and Maintenance Manual, "Operator Controls" for more information.
4. Move the hydraulic lockout control to the UNLOCKED position. Refer to Operation and Maintenance Manual, "Operator Controls" for more information.

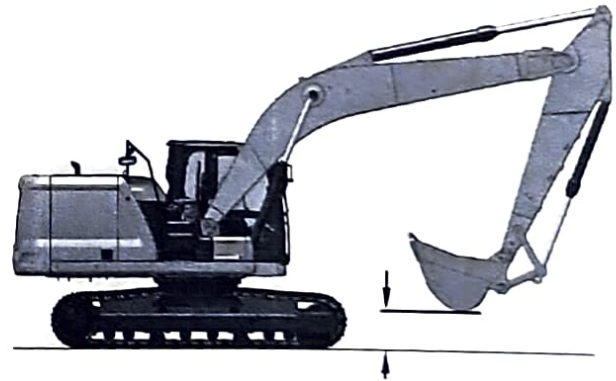

Illustration 190

g06181525

Typical example

5. Raise the boom enough to provide sufficient ground clearance.



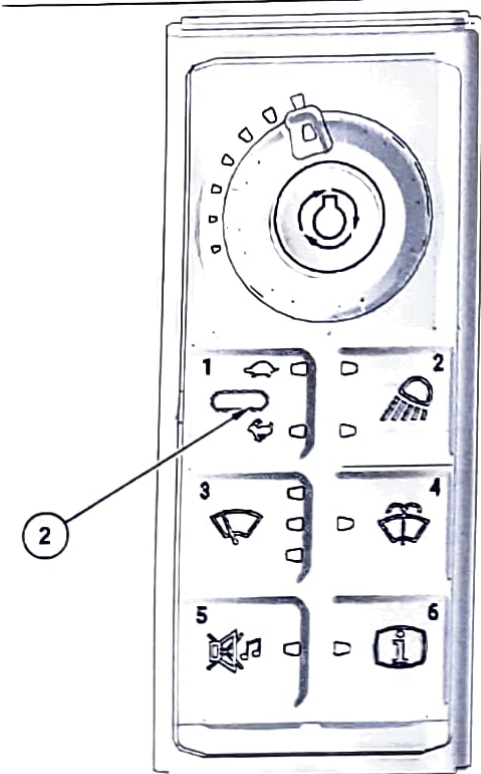

Illustration 191

g06685024

(2) Travel speed control switch

6. Select the desired travel speed by operating the travel speed control switch (2). The indicator will light to display the active mode. Refer to Operation and Maintenance Manual, "Operator Controls" for more information.

7. Make sure that the position of the upper structure and of the undercarriage is known before you move the machine. The drive sprockets should be at the rear of the machine.

**Note:** The directional steering controls will operate normally if the drive sprockets are at the rear of the machine and the idlers are at the front of the machine and under the cab. When the sprockets are under the cab, the travel controls will operate backward.

8. Turn the engine speed dial to increase the engine speed (rpm) to the desired speed.

9. Push both travel levers forward at the same time to travel forward. If both travel levers are pushed farther, the travel speed at the selected engine speed (rpm) will be faster.

**Note:** If the machine does not operate or if the machine does not travel in a straight line, consult your Cat® dealer.

10. Refer to Operation and Maintenance Manual, "Operator Controls" for information about spot turning and about pivot turns.

11. When you make turns in soft material, travel in a forward direction occasionally to clear the tracks.

12. Slowly move both of the travel levers or both of the travel pedals to the CENTER position to stop the machine. Refer to Operation and Maintenance Manual, "Operator Controls" for more information.

## Lifting Objects

Regional regulations may require the use of an overload warning device and boom and stick lowering control valves when used to lift objects.

The overload warning device (if equipped) must be adjusted for the bucket linkage and bucket size that is installed on the machine. Adjust the overload warning device for proper operation.

The setting for the overload warning device (if equipped) should be checked by an authorized dealer.

Contact your Cat® dealer for additional information.

i07310673

## Frozen Ground Conditions

SMCS Code: 7000

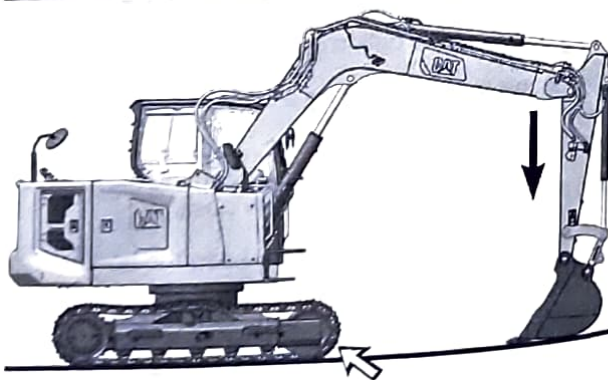

Illustration 192

g06278746

To free the tracks from frozen ground, swing the boom to the front of the machine. Use boom down pressure to free the idler end of the machine.

Swing the boom to the rear of the machine. Use boom down pressure to free the sprocket end of the machine.

i08581613

## Equipment Lowering with Engine Stopped

SMCS Code: 7000

### Machines without a Boom Lowering Control Valve

To lower the boom, place the hydraulic activation control lever in the UNLOCKED position. Move the joystick to the BOOM LOWER position. If the accumulator is still charged, the boom will lower.

If the boom does not lower, the accumulator has been depleted. Use the following method to lower the boom.

#### **WARNING**

Be sure no one is under or near the work tools before manually lowering the boom. Keep all personnel away from the boom drop area when lowering the boom with the engine stopped in order to avoid possible personal injury.

#### **WARNING**

Personal injury can result from oil under high pressure.

DO NOT allow high pressure oil to contact skin.

Wear appropriate protective equipment while working with high pressure oil systems.

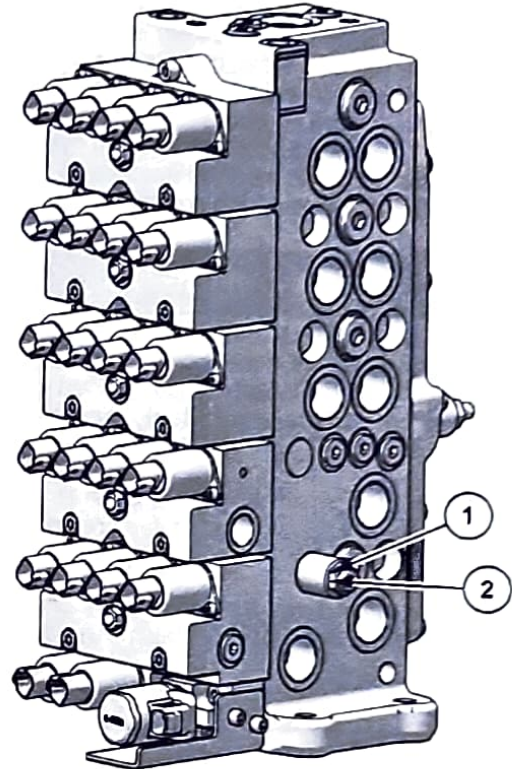

Illustration 193

g06711426

(1) Locknut  
(2) Valve

1. Open the access door on the right side of the machine.
2. While holding valve (2), loosen lock nut (1).
3. Slowly turn boom manual lowering valve (2) to lower the boom.
4. Make sure that the work tool has lowered all the way to the ground. Tighten boom manual lowering valve (2) and lock nut (1).
5. Make the necessary repairs before you operate the machine.



6. Close the access door.

## Machines with a Boom Lowering Control Valve

If the engine or the hydraulic system is disabled and the boom is up, the boom can be lowered manually. The boom lowering control valve allows the boom to be manually lowered. The boom lowering control valve is on the head end port on the boom cylinder. Use the following procedure if the machine is equipped with a boom lowering control valve:

### WARNING

Boom load may cause cylinder oil pressure to reach relief pressure of the boom lowering control device when the boom is supported by one cylinder. Boom can lower suddenly, causing possible injury or death.

To avoid possible injury or death, be sure no one is under or near the work tool before manually lowering the boom.

Keep all personnel away from the boom drop area when lowering the boom with the engine stopped.

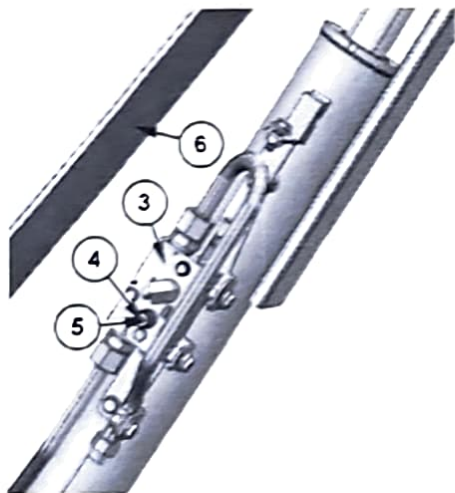

Illustration 194

g0E711430

- (3) Boom lowering control valve
- (4) Locknut
- (5) Set screw
- (6) Boom

**Note:** The boom lowering control valve is at the base of the boom cylinder. The boom lowering control device allows the operator to manually lower the boom if the engine is stopped. The boom lowering control device also prevents a sudden drop of the boom if there is an oil leak in the hydraulic line of the boom.

1. Release the pressure in the hydraulic system. Refer to Operation and Maintenance Manual, "System Pressure Release" for instructions.
2. Loosen locknut (4).
3. Slowly, turn set screw (5) counterclockwise until the boom begins to lower onto the ground.

**Note:** Once the boom begins to lower, stop turning set screw (5).

4. After the boom has lowered completely onto the ground, turn set screw (5) back to the original position.
5. Tighten locknut (4).
6. Make any necessary repairs before placing the excavator back into service.

**Note:** For further information, consult your Cat dealer.

## Blade (If Equipped)

To lower the blade, place the hydraulic lockout control in the UNLOCKED position. Move the blade control lever to the BLADE LOWER position. If the accumulator is still charged, the blade will lower.

If the blade does not lower, the accumulator is empty. The blade will need to be blocked in the raised position until the engine can be started again.

Additional instructions can be found in the service manual and/or consult your Cat dealer.

# Operating Techniques

i07310863

## Operating Technique Information

SMCS Code: 7000

### WARNING

Know the maximum height and the maximum reach of your machine. Serious injury or death by electrocution can occur if the machine or the work tools are not kept a safe distance from electrical power lines. Keep a distance of at least 3000 mm (118 inch) plus an additional 10 mm (0.4 inch) for each 1000 volts over 50000 volts.

For safety, one of the following may require a greater distance:

- Local codes
- State codes
- Requirements of the job site

### NOTICE

When swinging into a ditch, do not use the ditch to stop the swinging motion. Inspect the machine for damage if the boom is swung into a bank or an object.

Repeated stopping by an object can cause structural damage if the boom is swung into a bank or an object.

With certain boom-stick-bucket combinations, the bucket or worktool can hit the cab and/or the front structure of the machine. Always check for interference when first operating a new bucket or a new work tool. Keep the bucket or work tool away from the cab and away from the front structure during operation.

Whenever the tracks of the machine raise off the ground while digging, lower the machine back to the ground smoothly. **DO NOT DROP OR CATCH IT WITH THE HYDRAULICS.** Damage to the machine can result.

With certain combinations of work tools, the third pedal can have different functions. Always check the function of the third pedal before you use the third pedal.

Know the location of any buried cables. Mark the locations clearly before you dig.

Consult your Cat dealer for special work tool tips that are available for use in severe applications.

Move the machine whenever the position for operating the machine is not efficient. The machine can be moved forward or backward during the operating cycle.

When you operate the machine in close places, utilize the bucket or the other work tool to perform the following functions:

- Pushing the machine
- Pulling the machine
- Lifting the tracks

Use a comfortable travel speed while you operate the machine.

Operating efficiency can be increased by using more than one machine control to perform a task.

Never swing a load over a truck cab or workers.

Position the truck so that material can be loaded from the rear of the truck or from the side of the truck. Load the truck evenly so that the rear axles are not overloaded.

An oversize bucket or a bucket that is equipped with side cutters should not be used in rocky material. These types of buckets slow down the cycle. Damage to the bucket and to other machine components could result.

## Coaching Tips

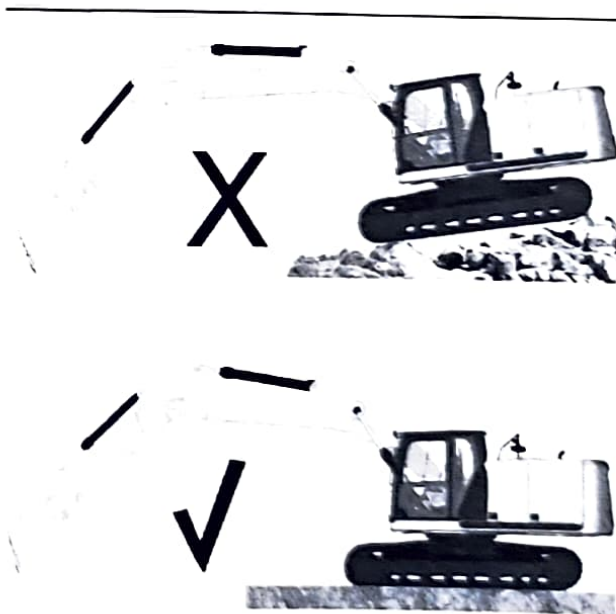

Illustration 195

g06223783

Digging with a stable machine increases productivity. Create a stable work platform.



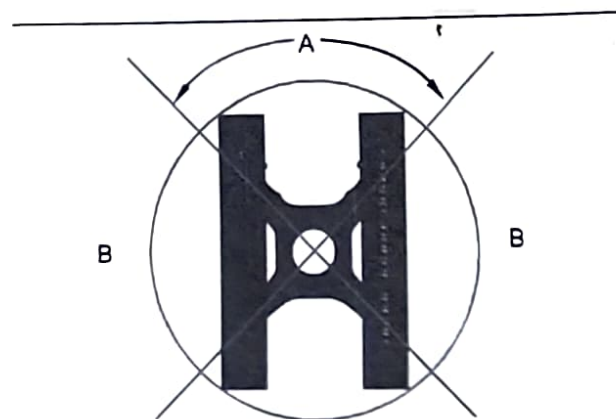

Illustration 196

g06210141

- (A) Most stable dig  
(B) Dump

For improved stability: Do not dig over the drives or perpendicular to the tracks

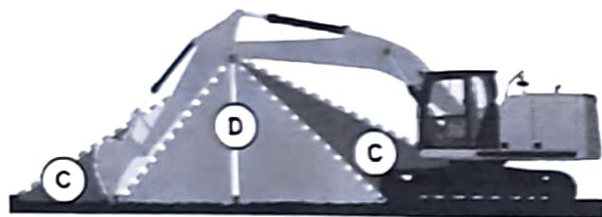

Illustration 197

g06212328

- (C) Weak crowd force  
(D) Ideal crowd force

Dig from the top down in layers. Try to have a full bucket by the time the stick is vertical, but do not reach too far with the stick. The most crowd force is generated with the stick +/- 30 degrees from vertical.

Minimize unneeded movement. Only curl/dump the bucket as much as required to hold/dump material.

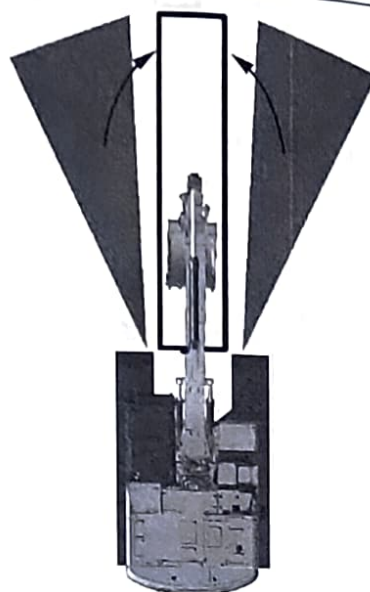

Illustration 198

g06210334

Minimize unneeded movement. During backfilling, start with the material closest to the trench.

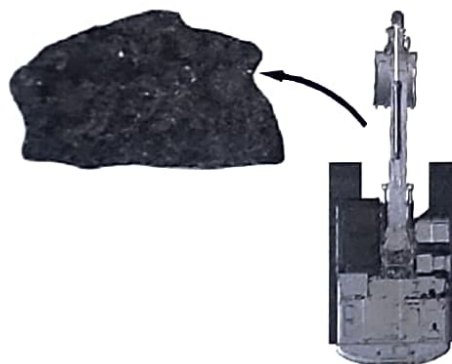

Illustration 199

g06210343

Watch your surroundings. Swing left to dump material for better visibility.

Watch the bucket. The bucket can contact the tracks or the cab.

Concentrate on being smooth, speed will come with practice.

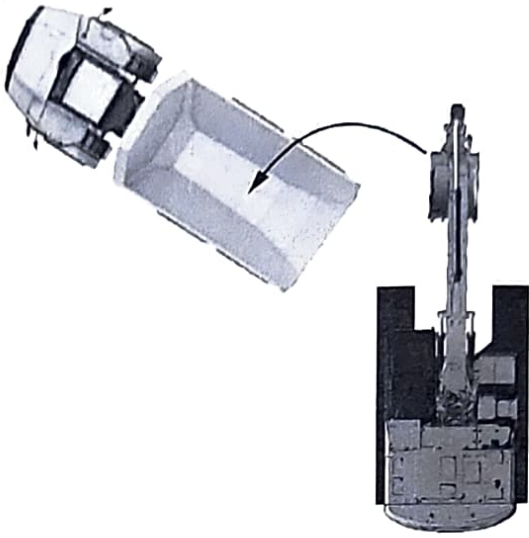

These operations will damage the boom, the stick, and the work tool and the operations will reduce the life of the equipment.



Illustration 200

g06212604

Truck placement will affect efficiency: 45 degree truck loading is more efficient than 90 degree. Spotting the truck too far from the excavator causes excessive motion.

Load from a bench when possible. Bench loading is more efficient.

Illustration 202

g06212594

Do not use the dropping force of the bucket or work tool as a hammer. This action will bring excessive force on the rear of the machine. Possible damage to the machine could result.

### Restricted Operation

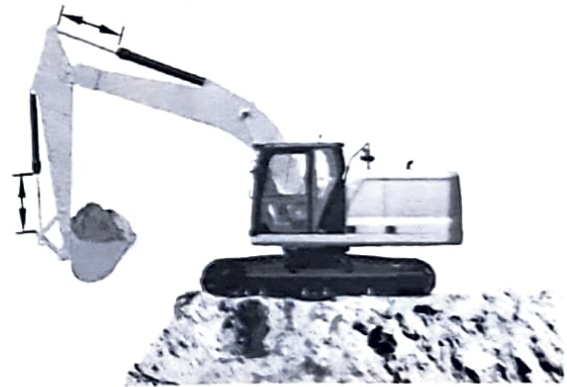

Illustration 201

g06222487

Do not use the swing force to perform the following operations:

- Soil compaction
- Ground breaking
- Demolition

Do not swing the machine while the bucket tips are in the soil

Illustration 203

g06222492

If the cylinder is operated at the end of the stroke during operations, excessive force will occur on the stopper on the inside of the cylinder. This practice will reduce the life of the cylinder and structures. To avoid this problem, always leave a small margin of play when the cylinder is operated.





Illustration 204

g06222498

If the stick IN function is operated at full speed with a fully loaded bucket or heavy work tool attachment to the end of the cylinder stroke, excessive force will occur inside the stick cylinder. This action will reduce the life of the stick cylinder. To avoid this problem, always operate a stick IN function with moderate speed towards the end of cylinder stroke.



Illustration 206

g06222505

Do not use the dropping force of the rear of the machine for excavation. This operation will damage the machine.

## Operating Precaution



Illustration 205

g06222506

While the bucket is in the ground, do not use the travel force for any excavation. This operation will cause excessive force on the rear of the machine.



Illustration 207

g06222507

**NOTICE**  
Do not allow the machine to swing from the force of traveling when you use the bucket, the stick, or the boom to assist in travel. If the force from traveling causes the machine to swing, damage may occur to the swing motor and to the swing drive.

Do not use the force of the bucket, the stick, or the boom to assist in turning the machine while the machine is traveling. This technique is referred to as "jump steering". This technique will damage the swing motor and the swing brake.



g06222509

Illustration 208

When deep holes are dug, do not lower the boom so that the bottom side of the boom touches the ground.

When deep holes are dug, do not allow the boom to interfere with the tracks.

i07310866

## Travel in Water and Mud

SMCS Code: 7000-V6

### NOTICE

When working in or around any body of water, around a stream or river, or in conditions of heavy mud, be careful that the swing bearing, the swing drive gear, and the swivel joint do not dip into water, mud, sand, or gravel. If the swing bearing dips into water, mud, sand, or gravel, immediately grease the swing bearing until the used grease leaks from the outer circle of the swing bearing. Failure to carry out this procedure may cause premature wear in the swing bearing.

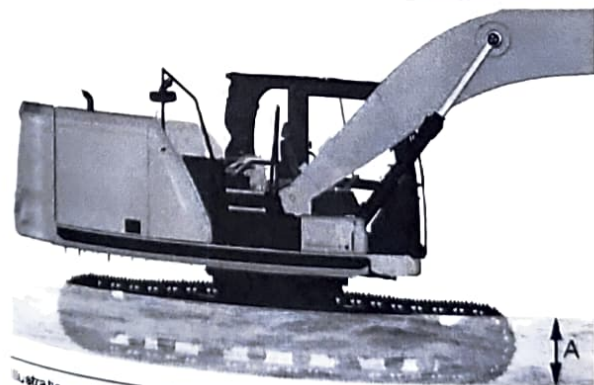

g06223764

Illustration 209

Depth of water to the center of the track carrier roller.

The following guidelines pertain to travel across water and travel through mud, sand, or gravel.

The machine can travel across a river only under the following conditions:

- The bed of the river is flat.
- The flow of the river is slow.
- The machine dips into the water only to the center of the track carrier roller (dimension A).

### NOTICE

Do not allow the fan on the engine to contact the water while the machine travels through the water. Do not allow the fan on the engine to contact the water during a swing while the machine is in the water. Damage to the fan may occur if the fan contacts the water.

While you cross the river, carefully confirm the depth of the water with the bucket. Do not move the machine into an area that has a water depth that is greater than Dimension A.

The machine may sink gradually on soft ground. Therefore, you should frequently check the height of the undercarriage from ground level and the depth of water on the ground.

Check the swing gear by looking through the port for inspection that is on the upper frame. If there is water in the swing gear, contact your Cat dealer for the required maintenance on the swing gear.

After you travel through water, carefully clean the machine to remove any salt, sand, or other foreign matter.

## Procedure for Removing the Machine from Water or Mud

### NOTICE

Do not allow the machine to swing from the force of traveling when you use the bucket, the stick, or the boom to assist in travel. If the force from traveling causes the machine to swing, damage may occur to the swing motor and to the swing drive.



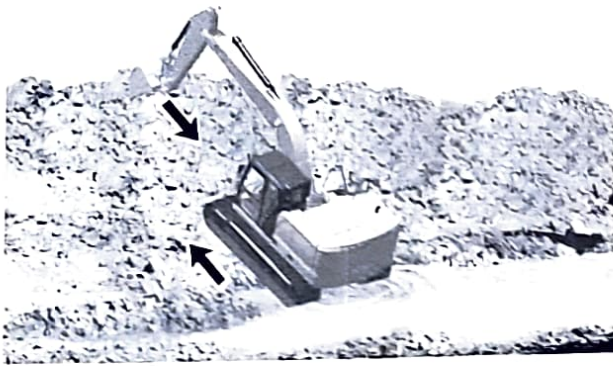

Illustration 210

g06222519

1. You may not be able to move the machine by using the travel controls only. In this case use both the travel control levers/pedals and the stick to pull the machine out of the water or ground.



Illustration 211

g06222525

2. The machine may slip because of a steep slope. The procedure in Step 1 may not work. In this case, first rotate the upper structure by 180°. Then use both the travel control levers/pedals and the stick to move the machine up the slope.

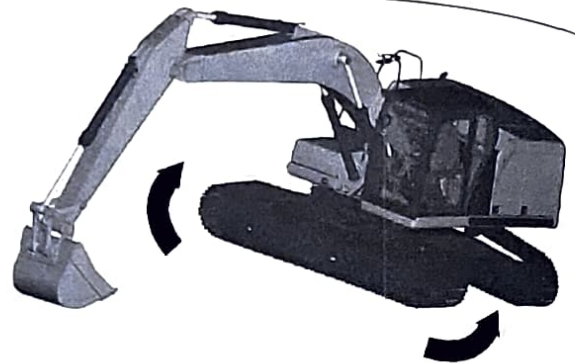

Illustration 212

g06212337

3. It may be impossible to travel because the bottom of the frame comes into contact with the ground or the undercarriage is clogged with mud or gravel. In this case, operate the boom and the stick together. Raise the track and rotate the track forward and backward to remove the mud and the gravel.

I08485621

## Boom, Stick and Bucket Operation

SMCS Code: 7000

### Digging

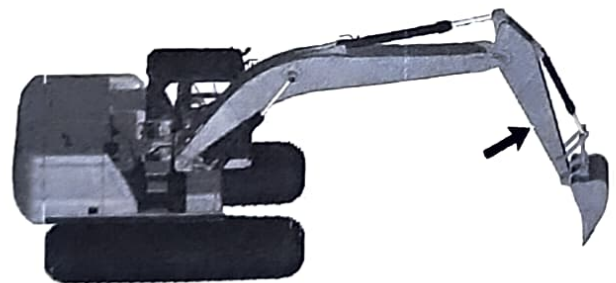
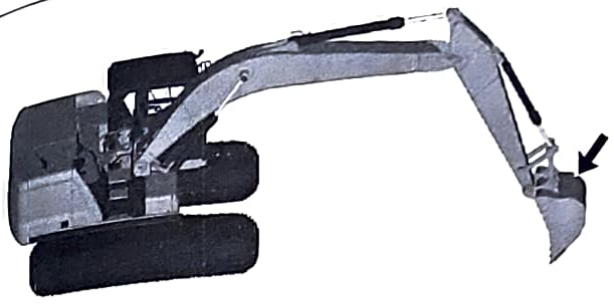

Illustration 213

g06212506

1. Position the stick at a 70 degree angle to the ground.



g06212513

Illustration 214

2. Position the bucket cutting edge at a 120 degree angle to the ground. Maximum breakout force can now be exerted with the bucket.



g06222533

Illustration 215

3. Move the stick toward the cab and keep the bucket parallel to the ground.



g06222535

Illustration 216

4. If the stick stops due to the load, raise the boom and/or perform a curl to adjust the depth of the cut.

- 5. To apply the greatest force at the cutting edge, decrease the down pressure as you move the stick toward the cab.
- 6. Maintain a bucket attitude that ensures a continuous flow of material into the bucket.
- 7. Continue the pass in a horizontal direction so that material peels into the bucket.



Illustration 217

g06222538

8. Close the bucket and raise the boom when the pass has been completed.

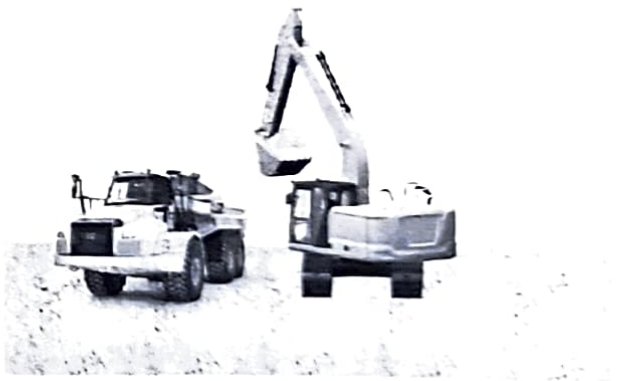

Illustration 218

g06223077

9. Engage the swing control when the bucket is clear of the excavation.





Illustration 219

g06223078

10. To dump a load, move the stick outward and open the bucket in a smooth motion.

## Lifting Objects

### WARNING

To prevent injury, do not exceed the rated load capacity of the machine. If the machine is not on level ground, load capacities will vary.

### NOTICE

Damage to bucket cylinder, bucket or linkage could result if slings are placed incorrectly.

There may be local regulations and/or government regulations that govern the use of machines which lift heavy objects. Obey all local and government regulations.

Regional regulations may require the use of an overload warning device and boom and stick lowering control valves when used to lift objects.

If this machine is used to lift objects within Japan, Japanese regulations require the machine to be equipped with a shovel crane configuration.

Contact your Cat® dealer for additional information.

Short slings will prevent excessive load swing.

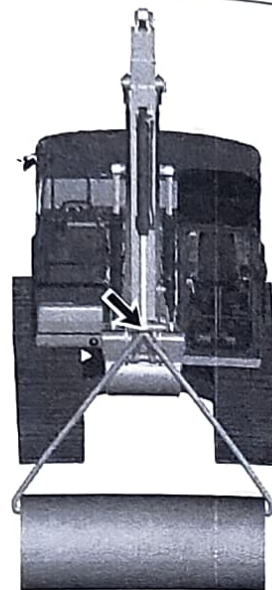

Illustration 220

g06212526

Use the lifting eye that is provided on the linkage to lift objects.

If the lifting eye is used, the connection must be made with a sling or with a shackle.



Illustration 221

g06212532

An unstable condition can exist if a load exceeds the machine load rating or if a heavy load is swung over an end or over a side.

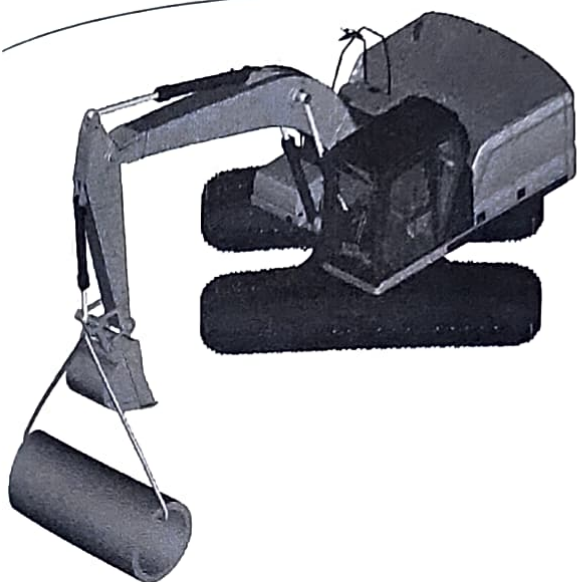

Illustration 222

g06212530

The most stable lifting position is over a corner of the machine.

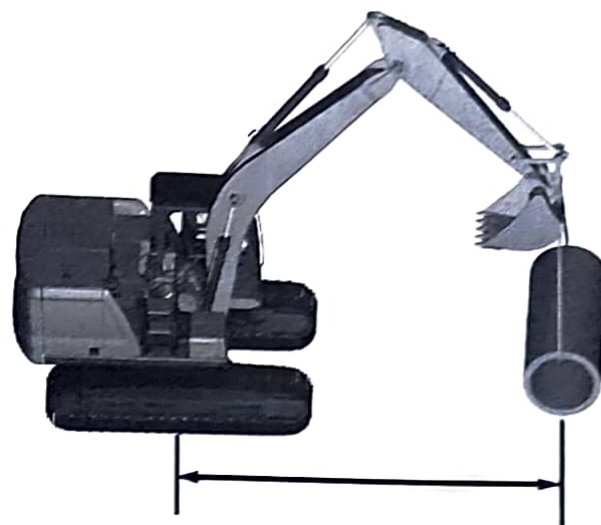

Illustration 224

g06212539

Lift capacity decreases as the distance from the swing centerline is increased.

### Machines that are Equipped with a Long Reach Configuration

Machines with a long reach configuration require larger swing drift than standard machines when stopping, because inertial force in time of swing is large. So adjustments are made in timing for applying the swing brakes and speed of swinging.

Machines with a long reach configuration could be damaged and stability of the machine would be adversely affected if a control was suddenly operated, because inertial force of work tool is large.

07329624

### Quick Coupler Operation (Pin Lock (If Equipped))

SMCS Code: 6129; 6522; 7000

### Installation

#### NOTICE

The vibration caused by extensive use of a hydraulic hammer as well as the added weight of certain demolition tools such as shears, crushers, and pulverizers may cause premature wear and decreased service life of the coupler.

Be sure to inspect the coupler daily for cracks, bent components, or wear when operating with any of the above work tools.

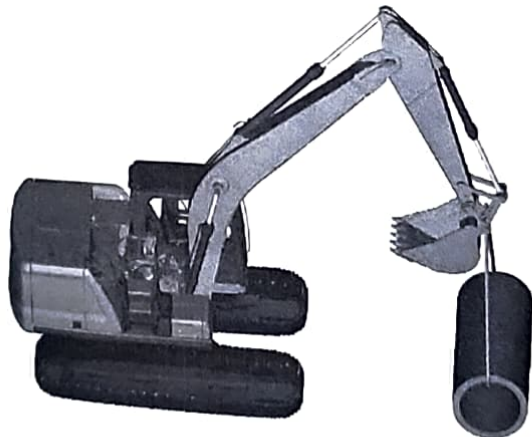

Illustration 223

g06212535

For the best stability, carry a load close to the machine and to the ground.



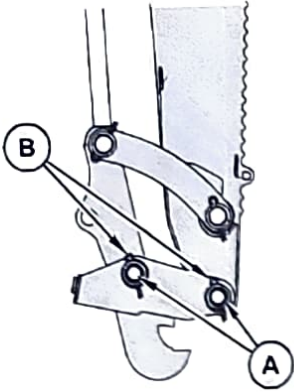

Illustration 225

g06286231

1. The quick coupler comes with two linkage pins (A) for installation on the machine. Lubricate the linkage pins (A) and pin bores before assembly on the machine.
2. Install the coupler and the linkage pins (A).
3. Install the cotter pins (B).

## Securing the Work Tool

### **⚠ WARNING**

Improper attachment of work tools could result in injury or death.

Do not operate this machine until you have positive indication that the coupler pins are fully engaged. Check for engagement by:

1. Position the work tool on the ground.
2. Apply slight down pressure on the work tool.
3. Retract and extend the stick cylinder in order to push the work tool against the ground. Visually confirm that there is no movement between the coupler and the work tool.

Position the work tool on a level surface.

1. Start the engine.

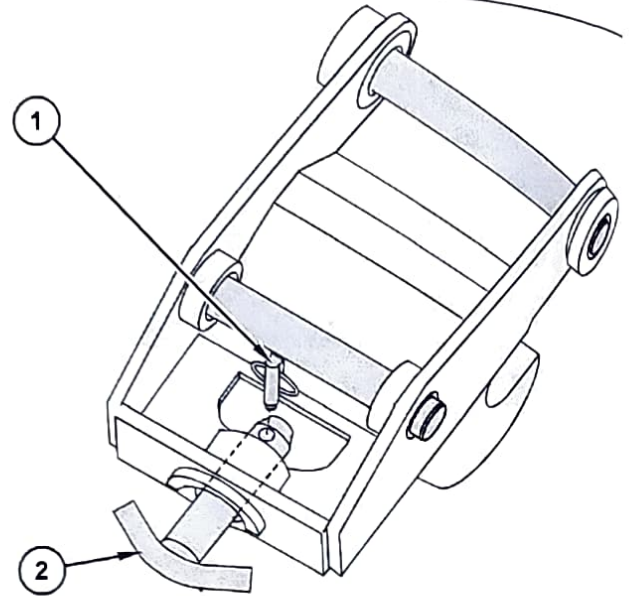

Illustration 226

g06286235

2. Remove the lock pin (1) and quick coupler pin (2) from the quick coupler.
3. Retract the work tool cylinder. Position the open hook on the quick coupler over the top pivot pin of the work tool.

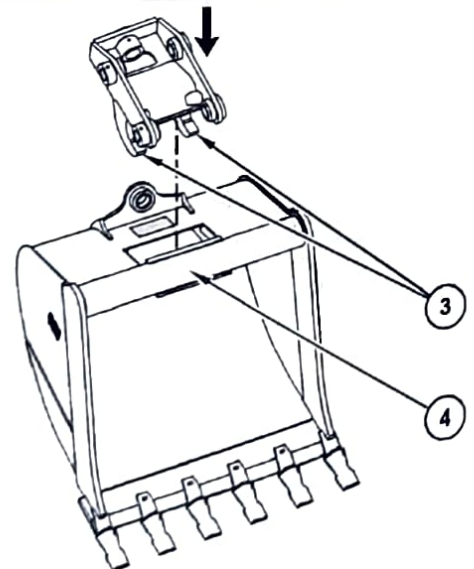

Illustration 227

g06286248

4. Move the stick inward and lower the stick until the hooks (3) engage the top pivot pin (4) of the work tool.

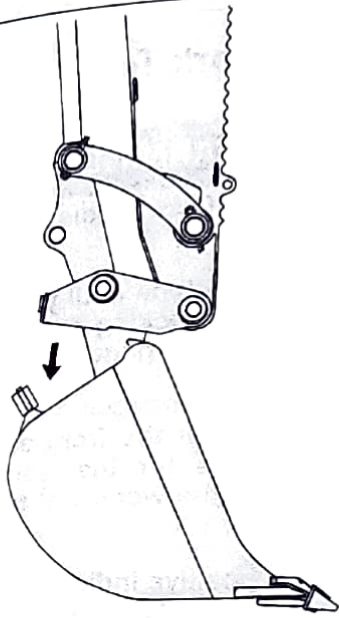

Illustration 228

g06286262

5. Extend the work tool cylinder to rotate the quick coupler toward the work tool. Line up the pin receiver of the work tool with the pin receiver of the quick coupler. Stop the engine.
6. Fully insert the quick coupler pin (2) into the pin receiver of the quick coupler and the work tool.

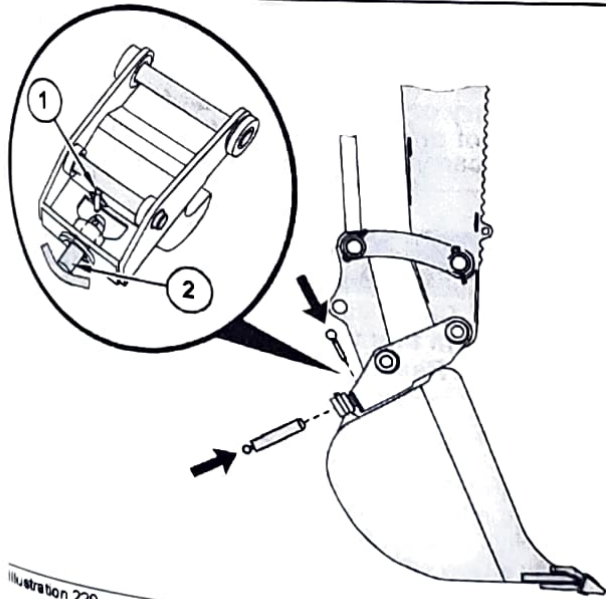

Illustration 229

g08288268

7. Fully insert the lock pin (1) into the quick coupler pin (2).
8. To verify the engagement of the work tool, perform the following procedure.

- a. Start the engine. Retract and extend the stick cylinder to push the work tool against the ground.
- b. Ensure that there is no movement between the work tool and the quick coupler.
- c. Visually confirm the engagement of the work tool.

## Releasing the Work Tool

### **⚠ WARNING**

Disengaging the coupler pins will release the work tool from control of the operator.

Serious injury or death may result from disengaging the work tool when it is in an unstable position or carrying a load.

Place the work tool in a safe position before disengaging the coupler pins.

1. Lower the work tool onto a level surface. Make sure that the work tool is in full contact with the ground.
2. Remove the lock pin from the quick coupler pin.
3. Remove the quick coupler pin from the quick coupler.
4. Rotate the quick coupler out of the top pivot pin of the work tool.

107329727

## Quick Coupler Operation (Mechanical Pin Grabber Quick Coupler (If Equipped))

SMCS Code: 6129; 6522; 7000

### NOTICE

The vibration caused by extensive use of a hydraulic hammer as well as the added weight of certain demolition tools such as shears, crushers, and pulverizers may cause premature wear and decreased service life of the coupler.

Be sure to inspect the coupler daily for cracks, bent components, or wear when operating with any of the above work tools.



## General Operation

The quick coupler is used to change work tools, with minimal effort on the operators part. The quick coupler can be used with a broad range of buckets and work tools. Each work tool must have a set of pins in order for the quick coupler to work properly.

The work tools are held onto the quick coupler by two independent locking mechanisms. The work tool rear pin locking mechanism consists of a wedge that is actuated by a mechanical threaded actuator. This actuator provides a positive lock and is adjustable to ensure a rigid, tight interface between the work tool and the quick coupler. Additionally, a fully independent locking system exists on the front pin of the work tool. This system is spring applied, ensuring that the work tool is locked immediately after the front pin of the work tool is seated. Always ensure that both locking mechanisms are working properly before using the quick coupler.

## Installation

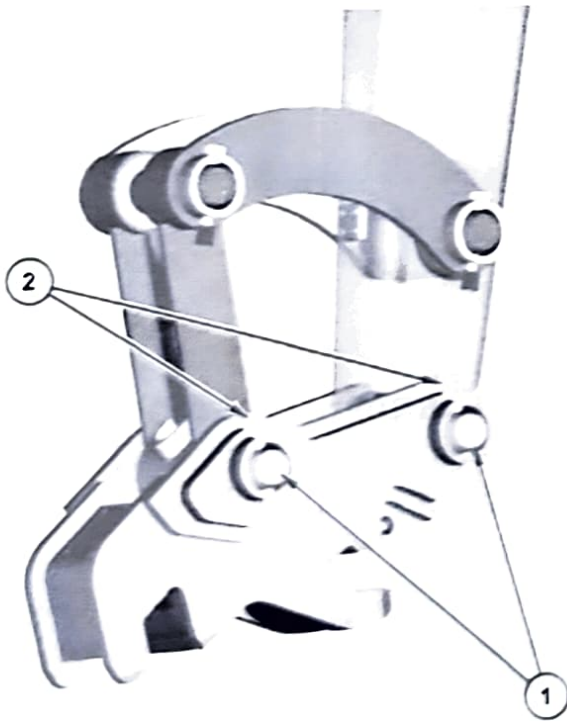

Illustration 230

g06296306

1. The quick coupler comes with two linkage pins (1) for installation on the machine. Lubricate the linkage pins (1) and pin bores before assembly on the machine.
2. Install the coupler and the linkage pins (1).

3. Install the cotter pins (2).

## Coupling the Work Tool

### **⚠ WARNING**

Improper attachment of work tools could result in serious injury or death.

Do not operate this machine until you have positive indication that the locking mechanisms are fully engaged. Check for engagement by:

- Visually confirm the engagement of the work tool. Ensure that both the front and rear pin locking mechanisms for the work tool are locked and secure the work tool to the quick coupler.
- Visually confirm positive indication of the ISO Engagement indicator, if equipped.
- Retract the bucket cylinder and drag the work tool on the ground.
- Visually confirm that there is no movement between the work tool and the quick coupler.

### **⚠ WARNING**

Place the work tool or bucket in a safe position before engaging the quick coupler. Ensure that the work tool or bucket is not carrying a load.

Serious injury or death may result from engaging the work tool or bucket when it is in an unstable position or carrying a load.

### **⚠ WARNING**

Crush injury. Could cause serious injury or death. Always confirm that the quick coupler is engaged onto the pins. Read the Operator's Manual.

**NOTICE**  
With certain work tool combinations, including quick couplers, the work tool can hit the cab or the front of the machine. Always check for interference when first operating a new work tool.

1. Start the engine. Retract the bucket cylinder, positioning the quick coupler front locking mechanism over the front pin of the work tool.

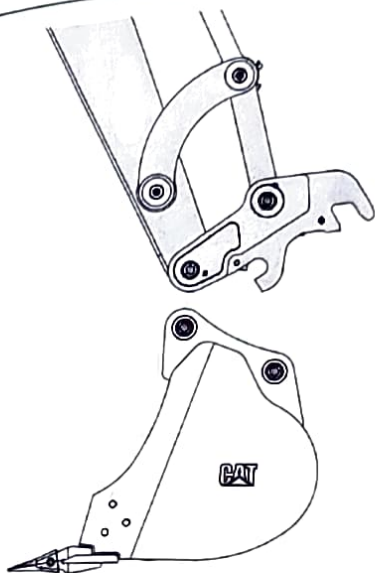

Illustration 231

g06286320

2. Align the quick coupler front locking mechanism over the front pin of the work tool. Extend the stick cylinder until the automatic front locking mechanism of the quick coupler engages and secures the front pin of the work tool.

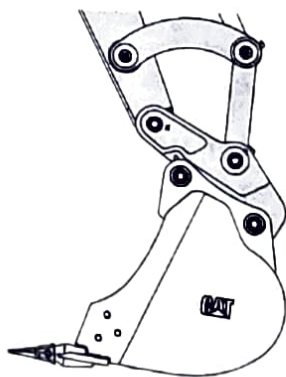

Illustration 232

g06286326

3. Extend the bucket cylinder to rotate the quick coupler toward the work tool until the quick coupler contacts the rear pin of the work tool. Position the work tool so that the work tool is slightly above the ground, with the front pin of the work tool higher than the rear pin of the work tool. If the work tool is a bucket, verify that the cutting edge is slightly higher than the bottom of the bucket. Stop the engine.

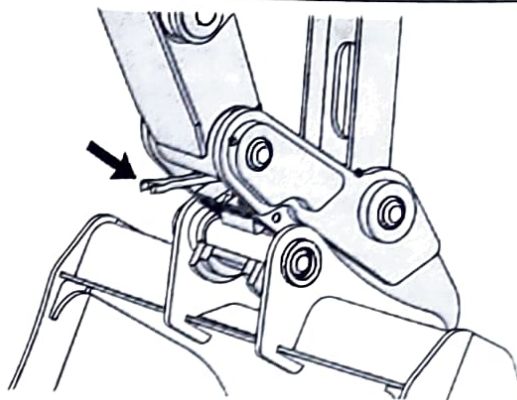

Illustration 233

g06286366

4. Using the supplied wrench, if equipped, and insert the ratcheting end onto the hex drive mechanism. Turn the ratchet in a clockwise direction to tighten the rear locking mechanism.
5. To verify the engagement of the work tool, perform the following procedure:
  - a. Visually confirm the engagement of the work tool. Ensure that both the work tool front and rear pin locking mechanisms are locked and securing the work tool to the coupler.
  - b. Retract the bucket cylinder and drag the work tool on the ground.
  - c. Visually confirm that there is no movement between the work tool and the quick coupler.

## Uncoupling the Work Tool

### **⚠ WARNING**

Place the work tool or bucket in a safe position before disengaging the coupler. Disengaging the coupler will release the work tool or bucket from control of the operator.

**Serious injury or death may result from disengaging the work tool or bucket when it is in an unstable position or carrying a load.**

### **NOTICE**

Auxiliary hoses for work tools must be disconnected before the Hydraulic Quick Coupler is disengaged.

Pulling the work tool with the auxiliary hoses could result in damage to the host machine or the work tool.



Operation Section  
Mechanical Pin Grabber Quick Coupler (If Equipped)

M0097987-10

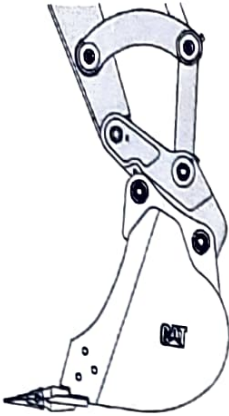

Illustration 234

g06286326

1. To unlock the coupler, position the work tool so that the work tool is slightly above the ground, with the front pin of the work tool higher than the rear pin of the work tool. If the work tool is a bucket, verify that the cutting edge is slightly higher than the bottom of the bucket. Other work tools may need to be lowered to the ground. Stop the engine.

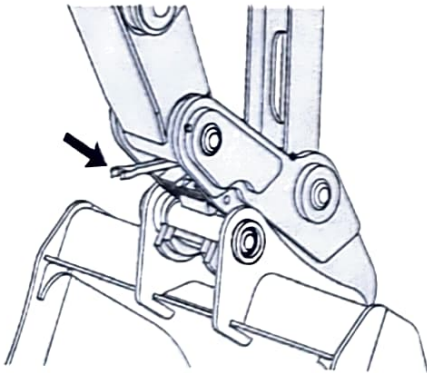

Illustration 235

g06286396

2. Using the supplied wrench, if equipped, and insert the ratcheting end onto the hex drive mechanism. Turn the wrench in a counterclockwise direction to release the rear locking mechanism.

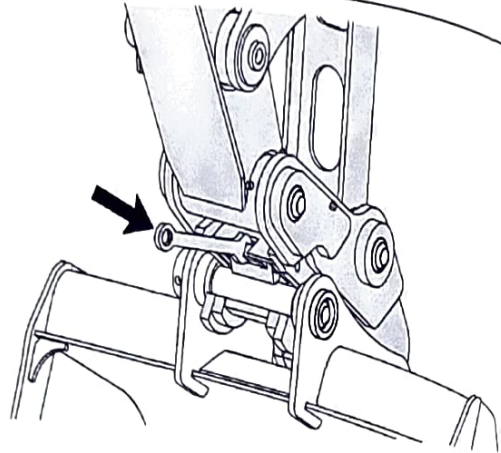

Illustration 236

g06286373

3. Using the supplied wrench, if equipped, and insert the open wrench end onto the front lock actuator. Push down on the wrench to rotate the front lock into an unlocked, detent position.
4. Start the engine. Lower the work tool to the ground.
5. Retract the bucket cylinder to rotate the quick coupler away from the work tool until the quick coupler disengages the rear pin of the work tool.
6. Move the stick away from the work tool to release the quick coupler from the front pin of the work tool. The front locking mechanism will automatically reset. The quick coupler is now ready to engage the next work tool.

### Quick Coupler use with a Bucket that is Reversed

#### NOTICE

When some Cat buckets are used in the reverse position, it can be more difficult to couple the bucket and uncouple the bucket than in the normal position.

Care must be taken to ensure that the position of the boom, stick, and bucket are aligned to ensure smooth coupling. The coupler must be in position between the bucket bosses.

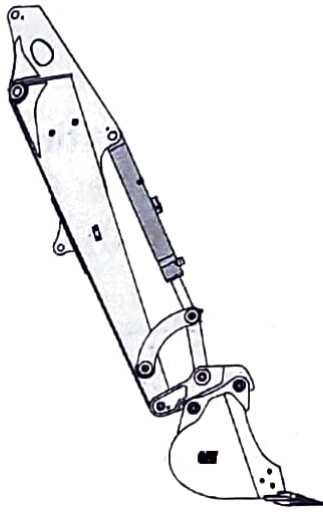

Illustration 237

g06286375

1. Follow the same steps for coupling and uncoupling the work tool to operate the coupler with a bucket that is reversed. Refer to "Coupling the Work Tool" and "Uncoupling the Work Tool" for the proper procedure.

i07330204

## Quick Coupler Operation (Dual Lock Tilt Coupler (If Equipped))

SMCS Code: 6129; 6522; 7000

The quick coupler is used to change work tools while the operator remains in the cab. The quick coupler can be used with a broad range of buckets and work tools. Each work tool must have a set of pins in order for the quick coupler to work properly. The Dual Lock Tilt Quick Coupler also allows the work tool to rotate through a 180 degree arc.

The work tools are held onto the quick coupler by two independent locking mechanisms. The work tool rear pin locking mechanism consists of a hydraulically driven wedge. If pressure is lost, a check valve in the hydraulic cylinder traps oil to ensure that the lock remains in place. Additionally, a fully independent locking system exists on the front pin of the work tool. This system is spring applied and hydraulically released, ensuring that the work tool is locked immediately after the front pin of the work tool is seated. Always ensure that the hydraulic system and the locking mechanisms are working properly before using the quick coupler.

### WARNING

Improper attachment of work tools could result in serious injury or death.

Do not operate this machine until you have positive indication that the locking mechanisms are fully engaged. Check for engagement by:

- Visually confirm the engagement of the work tool. Ensure that both the front and rear pin locking mechanisms for the work tool are locked and secure the work tool to the quick coupler.
- Visually confirm positive indication of the ISO Engagement indicator, if equipped.
- Retract the bucket cylinder and drag the work tool on the ground.
- Visually confirm that there is no movement between the work tool and the quick coupler.

### WARNING

Place the work tool or bucket in a safe position before engaging the quick coupler. Ensure that the work tool or bucket is not carrying a load.

Serious injury or death may result from engaging the work tool or bucket when it is in an unstable position or carrying a load.

### WARNING

Crush injury. Could cause serious injury or death. Always confirm that the quick coupler is engaged onto the pins. Read the Operator's Manual.

### NOTICE

Before beginning installation, operating of machine, or repair of the Dual Lock Tilt Coupler:

The Dual Lock Tilt Coupler should only be used to perform tasks for which it was designed. Abusing the product and/or using it for purposes for which it was not intended can expose the operator and others to hazards as well as result in damage to the Dual Lock Tilt Coupler, carrier and/or other attachments.

Modification to the Dual Lock Tilt Coupler is done at the owner's risk and may void warranty.



**NOTICE**

The buzzer will not sound when the switch is in the lock position. The position of the switch does not confirm that the quick coupler locking system is properly engaged with the attachment pins. Visually confirm positive indication of the ISO Engagement Indicator, if equipped. A physical test is required by dragging the work tool on the ground to confirm that the coupler pins are engaged.

**NOTICE**

Always confirm that the buzzer sounds when the switch is in the unlock position. If no sound is heard while in this condition, ensure that the work tool is placed in a stable and safe position. Turn off the engine. Consult your Cat dealer.

**NOTICE**

With certain work tool combinations, including quick couplers, the work tool can hit the cab or the front of the machine. Always check for interference when first operating a new work tool.

## Quick Coupler Operation

Refer to Operation and Maintenance Manual, "Quick Coupler Operation (Hydraulic Pin Grabber Quick Coupler)" for coupling and uncoupling the work tools.



Illustration 238

g06286461

**Actuate Tilt Coupler to the Right (1)** – Push the thumb wheel on the right joystick upward to tilt the coupler to the right.

**Actuate Tilt Coupler to the Left (2)** – Push the thumb wheel on the right joystick downward to tilt the coupler to the left.

**DO NOT** actuate angling of the coupler while in the process of digging. Angle actuation should be performed while the coupler is in the air and not engaged in material.

**DO NOT** operate the Dual Lock Tilt Coupler unless it is fully connected to a host machine. Auxiliary lines must be connected at all times to provide pressure relief.

107518343

## Quick Coupler Operation (Hydraulic Pin Grabber Quick Coupler (If Equipped))

**SMCS Code:** 6129; 6522; 7000

**NOTICE**

The vibration caused by extensive use of a hydraulic hammer as well as the added weight of certain demolition tools such as shears, crushers, and pulverizers may cause premature wear and decreased service life of the coupler.

Be sure to inspect the coupler daily for cracks, bent components, or wear when operating with any of the above work tools.

## General Operation

The quick coupler is used to change work tools while the operator remains in the cab. The quick coupler can be used with a broad range of buckets and work tools. Each work tool must have a set of pins in order for the quick coupler to work properly.

The work tools are held onto the quick coupler by two independent locking mechanisms. The locks are controlled through a menu on the monitor system. Refer to Operation and Maintenance, "Monitoring System" for more information. The work tool rear pin locking mechanism consists of a hydraulically driven wedge. If pressure is lost, a check valve in the hydraulic cylinder traps oil to ensure that the lock remains in place. Additionally, a fully independent locking system exists on the front pin of the work tool. This system is spring applied and hydraulically released, ensuring that the work tool is locked immediately after the front pin of the work tool is seated. Always ensure that the hydraulic system and the locking mechanisms are working properly before using the quick coupler.

### Installation

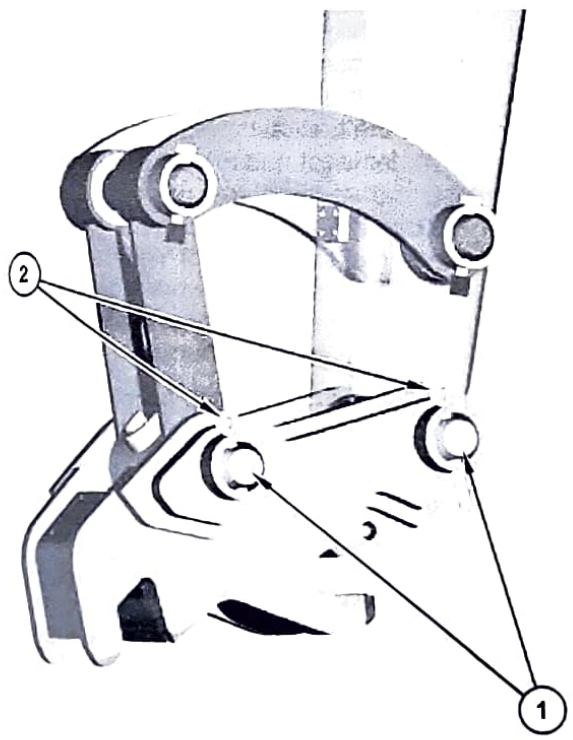

Illustration 239

g06286309

1. The quick coupler comes with two linkage pins (1) for installation on the machine. Lubricate the linkage pins (1) and pin bores before assembly on the machine.
2. Install the coupler and the linkage pins (1).

3. Install the cotter pins (2).

## Quick Coupler Operation

### Coupling the Work Tool

**⚠ WARNING**

Improper attachment of work tools could result in serious injury or death.

Do not operate this machine until you have positive indication that the locking mechanisms are fully engaged. Check for engagement by:

- Visually confirm the engagement of the work tool. Ensure that both the front and rear pin locking mechanisms for the work tool are locked and secure the work tool to the quick coupler.
- Visually confirm positive indication of the ISO Engagement indicator, if equipped.
- Retract the bucket cylinder and drag the work tool on the ground.
- Visually confirm that there is no movement between the work tool and the quick coupler.

**⚠ WARNING**

Place the work tool or bucket in a safe position before engaging the quick coupler. Ensure that the work tool or bucket is not carrying a load.

Serious injury or death may result from engaging the work tool or bucket when it is in an unstable position or carrying a load.

**⚠ WARNING**

Crush injury. Could cause serious injury or death. Always confirm that the quick coupler is engaged onto the pins. Read the Operator's Manual.

### NOTICE

The buzzer will not sound when the switch is in the lock position. The position of the switch does not confirm that the quick coupler locking system is properly engaged with the attachment pins. Visually confirm positive indication of the ISO Engagement Indicator, if equipped. A physical test is required by dragging the work tool on the ground to confirm that the coupler pins are engaged.



**NOTICE**

Always confirm that the buzzer sounds when the switch is in the unlock position. If no sound is heard while in this condition, ensure that the work tool is placed in a stable and safe position. Turn off the engine. Consult your Cat dealer.

**NOTICE**

With certain work tool combinations, including quick couplers, the work tool can hit the cab or the front of the machine. Always check for interference when first operating a new work tool.

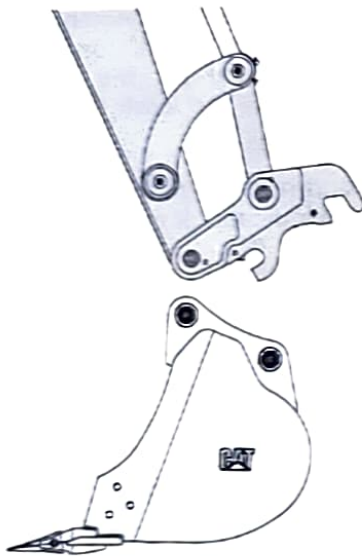

Illustration 240

g06286320

1. Align the quick coupler front locking mechanism over the front pin of the work tool. Extend the stick cylinder until the automatic front locking mechanism of the quick coupler engages and secures the front pin of the work tool.

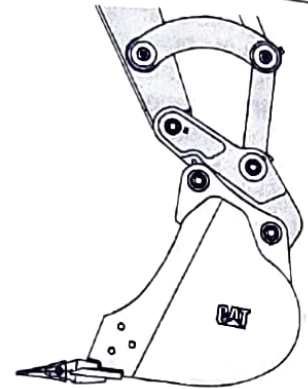

Illustration 241

g06286326

2. Select "UNLOCK WEDGE" on the monitor display and confirm that the buzzer is sounding with an intermittent pattern of one beep per second. If no sound is heard while in this condition, ensure that the work tool is placed in a stable and safe position. Turn off the engine. Consult your Cat dealer. Extend the bucket cylinder until the rear of the quick coupler is rotated toward the work tool and contacts the work tool rear pin. Position the work tool so that it is slightly above the ground, with the front pin of the work tool higher than the rear pin of the work tool. If the work tool is a bucket, verify that the cutting edge is slightly higher than the bottom of the bucket.
3. Select "LOCK WEDGE" on the monitor display and the beep will stop and the rear lock (wedge) will slide back into place. The monitor will return to the home screen.

**WARNING**

**Crush injury. Could cause serious injury or death. Always confirm that the quick coupler is engaged onto the pins. Read the Operator's Manual.**

4. To verify the engagement of the work tool, perform the following procedure:

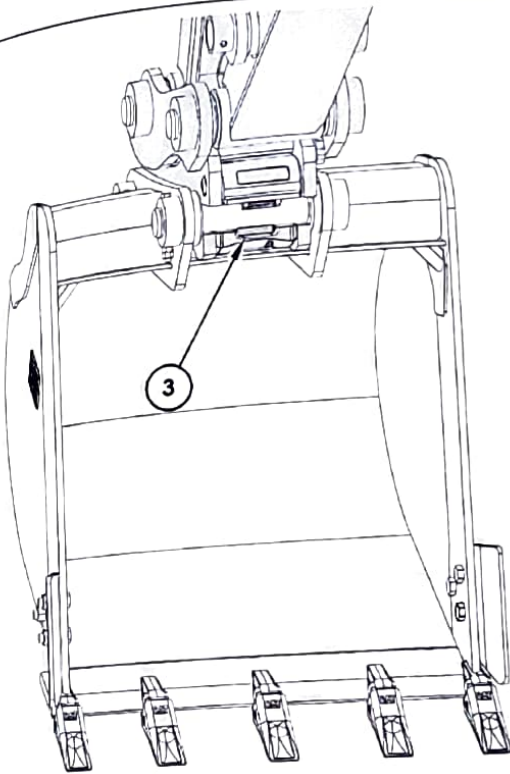

Illustration 242

g06286450

- Visually confirm the engagement of the work tool. Ensure that both the work tool front and rear pin locking mechanisms are locked and securing the work tool to the coupler.
- Visually confirm positive indication of the ISO Engagement indicator (3), if equipped.
- Retract the bucket cylinder and drag the work tool on the ground.
- Visually confirm that there is no movement between the work tool and the quick coupler.

**NOTICE**

Back drag the work tool on the ground to ensure the quick coupler is properly locked.

Do Not strike the work tool on the ground to ensure the quick coupler is properly locked. Striking the work tool on the ground will result in damage to the coupler cylinder.

## Uncoupling the Work Tool

### **WARNING**

Place the work tool or bucket in a safe position before disengaging the coupler. Disengaging the coupler will release the work tool or bucket from control of the operator.

Serious injury or death may result from disengaging the work tool or bucket when it is in an unstable position or carrying a load.

**NOTICE**

Auxiliary hoses for work tools must be disconnected before the Hydraulic Quick Coupler is disengaged.

Pulling the work tool with the auxiliary hoses could result in damage to the host machine or the work tool.

**NOTICE**

Always confirm that the buzzer sounds when the switch is in the unlock position. If no sound is heard while in this condition, ensure that the work tool is placed in a stable and safe position. Turn off the engine. Consult your Cat dealer.

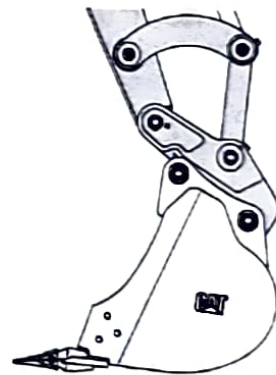

Illustration 243

g06286326

- To unlock the coupler, position the work tool so that it is slightly above the ground, with the front pin of the work tool higher than the rear pin of the work tool. If the work tool is a bucket, verify that the cutting edge is slightly higher than the bottom of the bucket.
- Press the button for the "UNLOCK WEDGE". Confirm that the buzzer is sounding with an intermittent pattern of one beep per second. If no sound is heard while in this condition, ensure that the work tool is placed in a stable and safe position. Turn off the engine. Consult your Cat dealer.



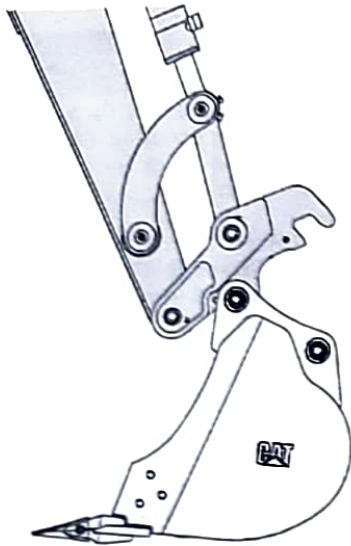

Illustration 244

g06286443

3. Retract the bucket cylinder, ensuring that the work tool rear pin locking mechanism is unlocked. The rear of the quick coupler should be rotated away from the work tool. Place the work tool in a stable and safe position on the ground.
4. Select "UNLOCK FRONT" on the monitor display. Confirm that the buzzer is sounding with an intermittent pattern of two beeps per second. The work tool front pin locking mechanism will unlock. This locking mechanism will remain unlocked for 10 seconds.

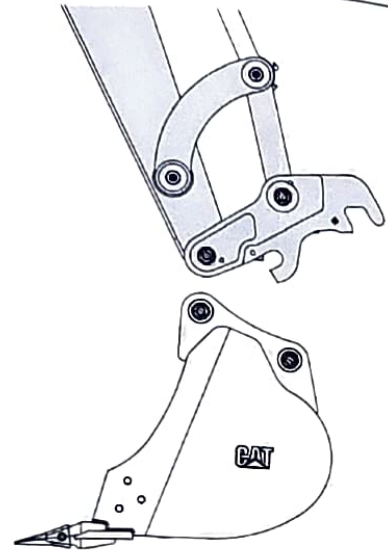

Illustration 245

g06286320

5. Within the 10-second time period, retract the stick cylinder until the quick coupler is disengaged from the work tool. Ensure that the work tool is in a stable and safe storage position on the ground.
6. Select "LOCK WEDGE" on the monitor display and the beep will stop and the rear lock (wedge) will slide back into place. The monitor will return to the home screen.

### Coupling a Bucket that is Reversed

#### NOTICE

When some Cat buckets are used in the reverse position, it can be more difficult to couple the bucket and uncouple the bucket than in the normal position.

Care must be taken to ensure that the position of the boom, stick, and bucket are aligned to ensure smooth coupling. The coupler must be in position between the bucket bosses.

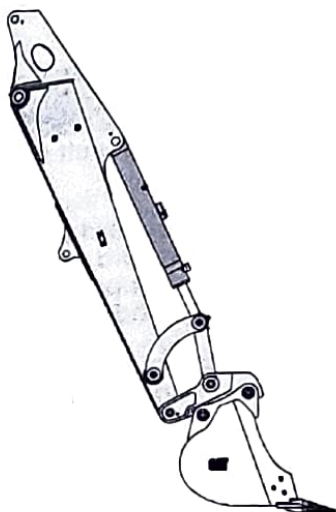

Illustration 246

g06286375

1. Follow the same steps for coupling and uncoupling the work tool to operate the coupler with a bucket that is reversed. Refer to "Coupling the Work Tool" and "Uncoupling the Work Tool" for the proper procedure.

i08504166

## Quick Coupler Operation

### (CW (Single Lock) Quick Coupler (If Equipped))

SMCS Code: 6129; 6522; 7000

#### NOTICE

The vibration caused by extensive use of a hydraulic hammer and the added weight of certain demolition tools such as shears, crushers, and pulverizers may cause premature wear and decreased service life of the coupler.

Be sure to inspect the coupler daily for cracks, bent components, or wear when operating with any work tools.

## General Operation

The CW coupler is used to change work tools quickly. The quick coupler can be used with a broad range of buckets and work tools.

## Installation Procedure

### WARNING

Personal injury or death can result from improperly checking for a leak.

Always use a board or cardboard when checking for a leak. Escaping air or fluid under pressure, even a pin-hole size leak, can penetrate body tissue causing serious injury, and possible death.

If fluid is injected into your skin, it must be treated immediately by a doctor familiar with this type of injury.

**Note:** Hydraulic oil may be trapped in the lines if the hydraulic lines are plugged or if the hydraulic lines are connected. The trapped oil may be under pressure. Use care when you open the hydraulic lines.

**Note:** The quick coupler must be controlled by the excavator's hydraulic system.

Perform this procedure as described in the following steps:

Ensure that the quick coupler is compatible with the host machine. For more information, consult your Caterpillar dealer.

To provide a stable operating condition, the host machine must be on flat, level ground. The host machine must be blocked to prevent inadvertent movement.

The quick coupler must be supported to prevent inadvertent movement. Position the quick coupler to prevent unnecessary climbing and unnecessary bending.

Optimum alignment of the bores will prevent the use of unnecessary force when you install the pins. Never check the alignment of the bores with your fingers. Use the proper tools to check the alignment of the bores.

A retaining pin can fly out when the retaining pin is struck with force. The area must be clear of people when you drive retaining pins.

When you strike objects, chips and other debris can fly. Before you strike any object, make sure that no one can be injured by the flying debris. Always wear appropriate PPE, including safety glasses.



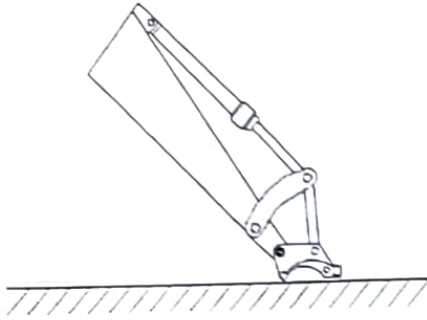

Illustration 247

g00741430

1. Position the quick coupler on the ground in front of the host machine. Make sure that the wedge faces away from the host machine.
2. Install the mounting pins.
3. Lubricate all the mounting points.
4. Connect the hydraulic lines to the quick coupler (if equipped).
5. After mounting the quick coupler on the excavator, or after working on the quick coupler hydraulic system, it is necessary to purge all the air from the cylinder and the control system. Refer to the "Hydraulic System Air Purge" for additional information.

## Quick Coupler Removal Procedure

1. Lay the quick coupler flat on the ground.
2. Release the pressure from the hydraulic lines (if equipped).
  - a. Extend the wedge to the UNLOCKED position
  - b. Stop the engine on the host machine. Turn the ignition to OFF
  - c. Turn the ignition to the ON position without starting the engine
  - d. Move the hydraulic control levers repeatedly through the full range of motion. This will release any pressure that may be present in the hydraulic system. Actuate the quick coupler using the machine control monitor. Cycle through locking and unlocking the quick coupler several times to release trapped hydraulic pressure within the quick coupler circuit
- e. The wedge should begin to move inward due to the spring force

- f. Turn the ignition to the OFF position.
- g. Release the pressure in the host machine's hydraulic tank.

### WARNING

Personal injury or death can result from improperly checking for a leak.

Always use a board or cardboard when checking for a leak. Escaping air or fluid under pressure, even a pin-hole size leak, can penetrate body tissue causing serious injury, and possible death.

If fluid is injected into your skin, it must be treated immediately by a doctor familiar with this type of injury.

### NOTICE

Care must be taken to ensure that fluids are contained during performance of inspection, maintenance, testing, adjusting, and repair of the product. Be prepared to collect the fluid with suitable containers before opening any compartment or disassembling any component containing fluids.

Refer to Special Publication, PERJ1017, "Dealer Service Tool Catalog" for tools and supplies suitable to collect and contain fluids on Cat® products.

Dispose of all fluids according to local regulations and mandates.

3. Place a suitable container below the hydraulic fittings to catch any hydraulic oil that may escape. Slowly disconnect the hydraulic lines. Plug the ends of the hydraulic lines or connect the hydraulic lines.
4. Dispose of the hydraulic oil in a suitable manner.
5. Remove the pins from the quick coupler.

## Daily Inspection

### WARNING

Personal injury or death can result from improperly checking for a leak.

Always use a board or cardboard when checking for a leak. Escaping air or fluid under pressure, even a pin-hole size leak, can penetrate body tissue causing serious injury, and possible death.

If fluid is injected into your skin, it must be treated immediately by a doctor familiar with this type of injury.

**NOTICE**

Accumulated grease and oil on a work tool is a fire hazard.

Remove debris with steam cleaning or high pressure water at any time a significant quantity of oil is spilled on the work tool.

**Note:** If major repairs to the quick coupler are required, consult your Caterpillar dealer.

1. For the maximum service life of the work tool, make a thorough daily inspection before you mount a work tool to the host machine.
2. Inspect the quick coupler for the following conditions: loose bolts, oil leaks, broken parts, missing parts and cracked components. Check the overall condition of the quick coupler. Check the overall condition of the hydraulic system.
3. Inspect the warning signs and labels. Replace warning signs or labels that are missing. Replace warning signs or labels when you cannot read the warning signs or labels.
4. If equipped, inspect the condition of the hydraulic lines and the hydraulic fittings.
5. Check the mounting pins for the quick coupler.
6. Inspect the bolts for the wedge when you remove the wedge.
7. Check the lifting device, if equipped. If damage is present, do not use the lifting device. Contact your Caterpillar dealer for repairs.
8. Perform all repairs before you put the quick coupler into service.
9. Perform an UNLOCK and LOCK cycle of the wedge to provide a smooth operation of the wedge. This procedure is for the quick coupler with hydraulic coupling only.

**Operation****Coupling the Work Tool****WARNING**

Place the work tool or bucket in a safe position before engaging the quick coupler. Ensure that the work tool or bucket is not carrying a load.

Serious injury or death may result from engaging the work tool or bucket when it is in an unstable position or carrying a load.

**WARNING**

Crush injury. Could cause serious injury or death. Always confirm that the quick coupler is engaged onto the pins. Read the Operator's Manual.

**Reference:** For more information on connecting the quick coupler to the host machine, contact your dealer for special instructions.

**Quick Coupler with Hydraulic Coupling****WARNING**

Place the work tool or bucket in a safe position before engaging the quick coupler. Ensure that the work tool or bucket is not carrying a load.

Serious injury or death may result from engaging the work tool or bucket when it is in an unstable position or carrying a load.

**NOTICE**

The buzzer will not sound when the switch is in the lock position. The position of the switch does not confirm that the quick coupler locking system is properly engaged with the attachment pins. Visually confirm positive engagement of the locking system. A physical test is required by dragging the work tool on the ground to confirm that the coupler is properly engaged with the work tool.

**NOTICE**

Always confirm that the buzzer sounds when the switch is in the unlock position. If no sound is heard while in this condition, ensure that the work tool is placed in a stable and safe position. Turn off the engine. Consult your Cat dealer.

**NOTICE**

With certain work tool combinations, including quick couplers, the work tool can hit the cab or the front of the machine. Always check for interference when first operating a new work tool.

1. Verify that the wedge is in the unlocked position. If the wedge is not extended, extend the bucket cylinder. Then, extend the wedge.



**WARNING**

Ensure that the wedge is extended before coupling the work tool. Severe damage may occur. Failing to extend the wedge before coupling the work tool could result in a poorly coupled work tool or an uncoupled work tool.

Serious injury or death may result from an improperly coupled work tool.

2. Ensure that the mounting bracket of the work tool is in line with the host machine. The work tool must be facing the host machine. The mounting bracket must be at the top of the work tool.

**Coupling a Bucket**

Illustration 248

g01285027

1. Hook the forward pivot of the quick coupler into the hooks of the mounting bracket.

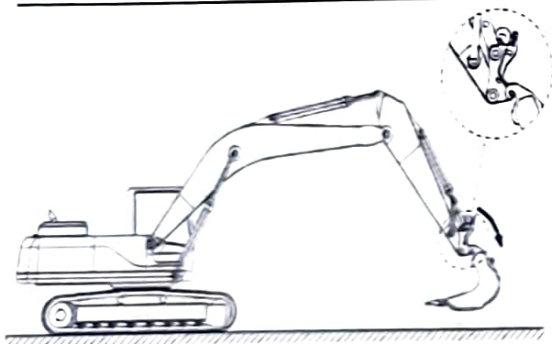
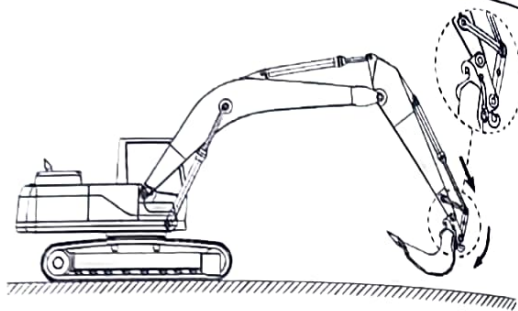

Illustration 249

g01285038

2. Select "UNLOCK" on the monitor display and confirm that the buzzer is sounding with an intermittent pattern of one beep per second. If no sound is heard while in this condition, ensure that the work tool is placed in a stable and safe position. Turn off the engine. Consult your Cat dealer. Extend the bucket cylinder until the coupler contacts the work tool.
3. Tilt the quick coupler against the work tool by extending the bucket cylinder.
4. Select "LOCK" on the monitor display and the beep will stop and the rear lock (wedge) will slide back into place. The monitor will return to the home screen.
5. Visually confirm that the wedge has engaged the work tool hook and is properly locked. If this visual confirmation cannot be performed from the machine cab due to obstruction, lighting, etc., place the machine in a safe state, exit the cab, and visually confirm proper engagement at the quick coupler.

**WARNING**

Inspect the quick coupler engagement before operating the machine.

Serious injury or death may result from improperly engaged coupler.

**NOTICE**

Visually confirm that the quick coupler engagement system is properly locked to the work tool. Confirm that the wedge has engaged the work tool hook and is properly locked.

6. Verify the engagement of the quick coupler and the work tool.

- a. Place the work tool on the ground.
- b. Apply pressure to the work tool against the ground.
- c. Drag the work tool forward and backward.

### Quick Coupler with Mechanical Coupling

#### WARNING

Place the work tool or bucket in a safe position before engaging the quick coupler. Ensure that the work tool or bucket is not carrying a load.

Serious injury or death may result from engaging the work tool or bucket when it is in an unstable position or carrying a load.

- 1. Ensure that the work tool mounting bracket is in line with the host machine. The work tool must be facing the host machine. The mounting bracket must be at the top of the work tool.

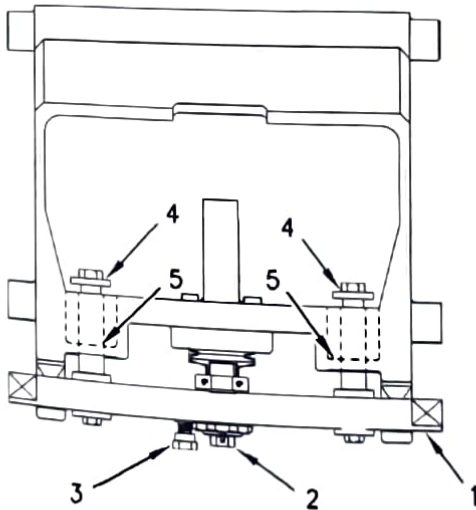

Illustration 250

g00928845

- 2. To move wedge (1) to the UNLOCKED position, perform the following steps:

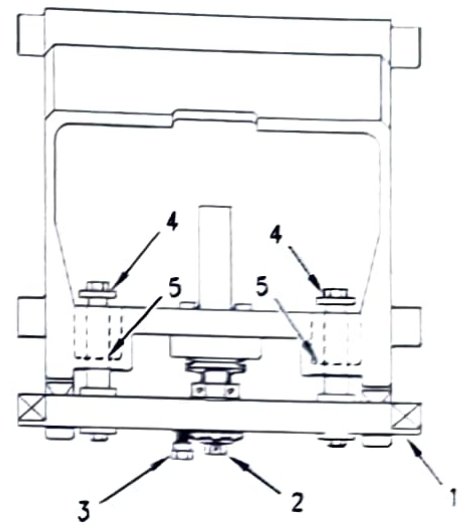

Illustration 251

g00928845

- 3. Loosen lock bolt (3) until you can turn spindle (2).

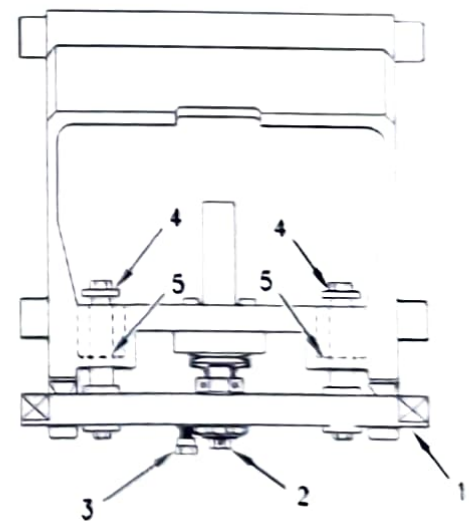

Illustration 252

g00928845

- 4. Turn spindle (2) until the bolts (4) lightly contact the coupler (5).
- 5. Position the coupler with the wedge in an UPWARD position.



**Coupling a Bucket**

Illustration 253

g01285027

1. Hook the front pivots into the hooks of the mounting bracket on the work tool.

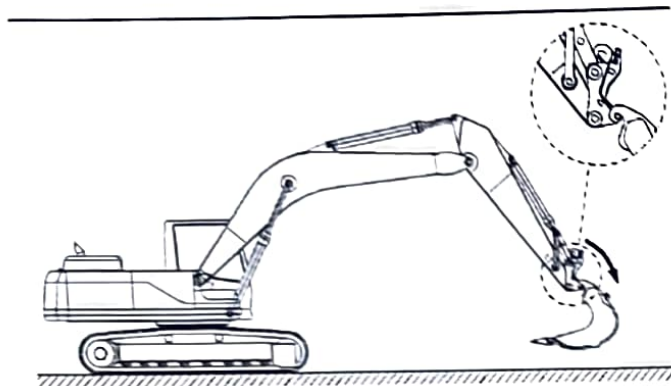
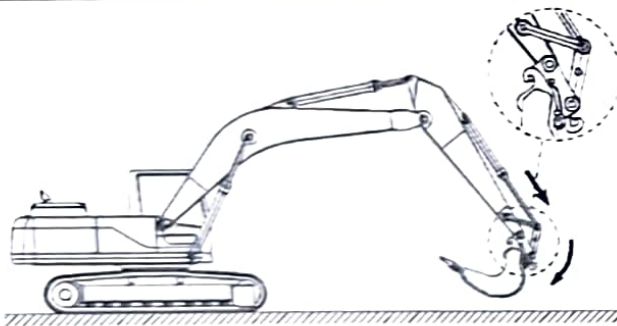

Illustration 254

g01285038

2. Tilt the quick coupler against the work tool by extending the bucket cylinder. Stop the engine of the host machine.
3. Turn the spindle inward. Tighten the spindle.

**Note:** If necessary, tighten the spindle until the next notch is aligned with the locking bolt.

4. Tighten the locking bolt.

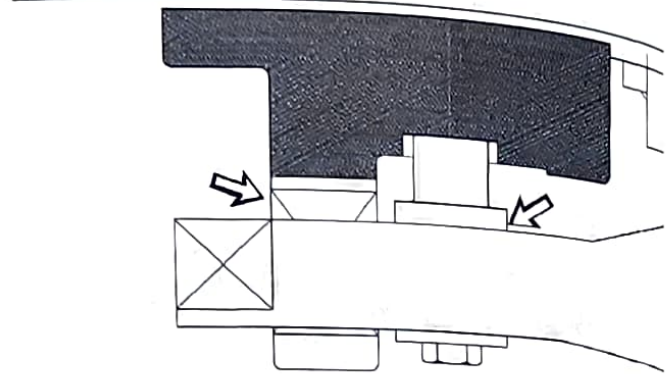

Illustration 255

g00583309

5. Ensure that there is a visible space between the wedge and the quick coupler frame. If there is not a space, the mounting bracket or the quick coupler may be damaged.

### **WARNING**

Inspect the quick coupler engagement before operating the machine.

Serious injury or death may result from improperly engaged coupler.

6. Verify the engagement of the quick coupler and the work tool.
  - a. Place the work tool on the ground.
  - b. Apply pressure to the work tool against the ground.
  - c. Drag the work tool forward and backward.

**Uncoupling the Work Tool**

Use the following steps to prepare the quick coupler for uncoupling.

**NOTICE**

Auxiliary hoses for work tools must be disconnected before the Hydraulic Quick Coupler is disengaged.

Pulling the work tool with the auxiliary hoses could result in damage to the host machine or the work tool.

1. Disconnect any auxiliary hoses from the work tool (if equipped).
2. Ensure that the work tool is clear of the ground.
3. Fully extend the bucket cylinder. Extend the stick cylinder until the wedge is pointing downward. The load is now released from the wedge.

### Quick Coupler with Hydraulic Coupling

#### **WARNING**

Place the work tool or bucket in a safe position before disengaging the coupler. Disengaging the coupler will release the work tool or bucket from control of the operator.

Serious injury or death may result from disengaging the work tool or bucket when it is in an unstable position or carrying a load.

1. Extend the wedge cylinder.
2. Select UNLOCK on the monitor display and confirm that the buzzer is sounding with an intermittent pattern of one beep per second. If no sound is heard while in this condition, ensure that the work tool is placed in a stable and safe position. Turn off the engine. Consult your Cat dealer.
3. Retract the bucket cylinder until the coupler is no longer in contact with the work tool. The work tool is now suspended by the front pivot.
4. Place the work tool on the ground.
5. Unhook the quick coupler from the mounting bracket.

### Quick Coupler with Mechanical Coupling

#### **WARNING**

Place the work tool or bucket in a safe position before disengaging the coupler. Disengaging the coupler will release the work tool or bucket from control of the operator.

Serious injury or death may result from disengaging the work tool or bucket when it is in an unstable position or carrying a load.

1. Stop the engine of the host machine.
2. Loosen the locking bolt until you can turn the spindle.
3. Turn the spindle outward. If necessary, strike the wedge with a hammer to release the wedge.
4. Retract the bucket cylinder. The work tool will be suspended by the front pivot.
5. Place the work tool on the ground.
6. Unhook the quick coupler from the mounting bracket.

### Lifting Loads

#### **WARNING**

Lifting loads with the quick coupler is only permitted when there is no work tool attached. Lifting loads when there is a work tool attached may result in serious injury or death.

#### NOTICE

If used to lift loads, then the excavator must comply with the requirements for lifting machinery. These are given in standard EN 474-5. For more information, consult your Caterpillar dealer.

**Note:** When you lift loads with the lifting yoke or the lifting hook, the wedge must be retracted or the wedge must be removed from the coupler.

#### Lifting Hook (If Equipped)

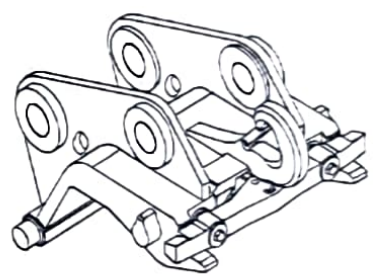

Illustration 256

g03219216

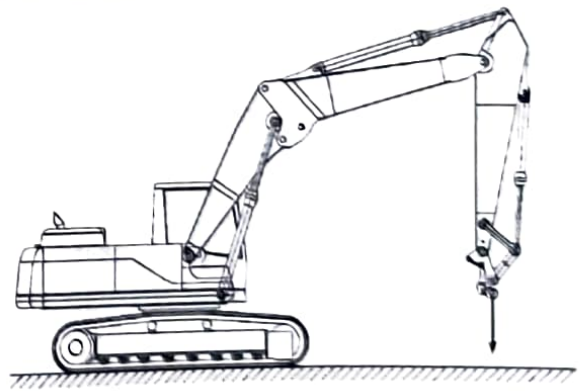

Illustration 257

g01285467

1. Fully extend the bucket cylinder.
2. Make sure that the wedge has been retracted or that the wedge has been removed.



**⚠ WARNING**

Use an appropriate lifting device that is rated for the specific load. Failure to do so can result in serious injury or death.

3. Fasten an appropriate chain, cable, or a lifting strap to the lifting hook. Do not perform any lifting operations if the safety latch is missing. Do not perform any lifting operations if the safety latch is damaged. Contact your supplier.

**Lifting Objects****⚠ WARNING**

To prevent injury, do not exceed the rated load capacity of the machine. If the machine is not on level ground, load capacities will vary.

The quick coupler and attached lifting hook have unique rated load capacities. Each capacity is marked on the corresponding component. Do not exceed the maximum capacity of any component used in a lifting operation. Quick coupler capacities are listed in the table below:

Table 37

Quick Coupler Rated Capacities <sup>(1)</sup>	
Quick Coupler Model	Rated Capacity
CW05	600 kg (1322 lb)
CW10	1400 kg (3086 lb)

<sup>(1)</sup> Capacities rated in accordance with EN 474-1:2006+A4:2013 Annex E and ASS 1418.8-2008 standards

Refer to the load charts in the Operation and Maintenance Manual of the host machine. Use the load charts and account for the mass of the work tool. Calculate the load capacity relative to the location of the lifting point on your specific host machine.

Use a sling or a shackle to attach to the lifting point and lift the object. The sling or the shackle must have a rated capacity that is greater than the mass of the load.

Regional regulations may require the use of an overload warning device and boom and stick lowering control valves when used to lift objects.

Contact your Cat dealer for additional information.

The setting for the overload warning device should be checked by an authorized dealer.

106978374

**Bucket - Remove and Install**

SMCS Code: 6001-012; 6001-011; 6001; 6101; 6102; 6523

**Removal Procedure****⚠ WARNING**

Failure to follow the instruction below for the installation of a work tool may result in personal injury or death. Special care must be taken if more than one person is installing the work tool.

- Confirm the verbal communication and the hand signals that will be used during the installation.
- Be alert for sudden movement of the front linkage and the work tool.
- Do not insert fingers into the bores of the support pins when the support pins and the bores are being aligned.

**NOTICE**

To facilitate removal of the bucket pins without causing damage to the pins, the bearings, and/or the O-ring seals put the bucket on the floor and the stick in a vertical position, as shown.

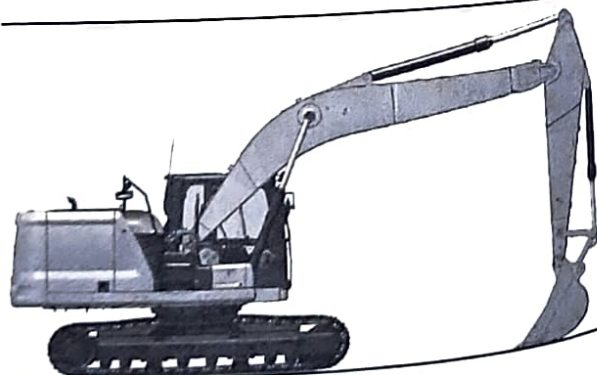

Illustration 258

g06181120

1. Start the engine. Park the machine on a hard, level surface. Position the bucket, the stick, and the bucket control linkage, as shown. Shut off the engine.

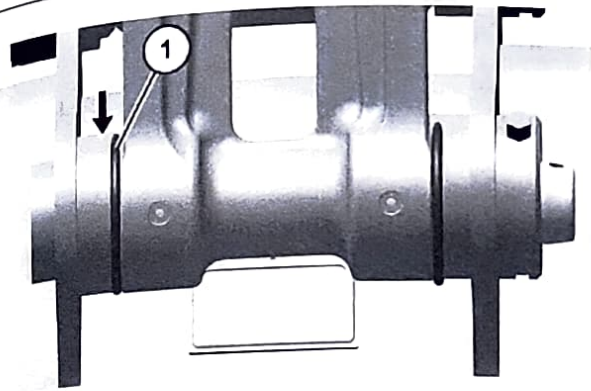

Illustration 259

g06192508

- Slide O-ring seals (1) off the pin joints and onto the flanges of the bucket.

### WARNING

When the pin assembly is removed, the linkage assembly may swing out of the bucket. To prevent possible personal injury, do not stand in front of the linkage assembly when the pin assembly is being removed.

**Note:** Removing the support pin may be difficult due to excessive pressure on the support pin. Remove the pressure on the support pin by adjusting the front linkage.

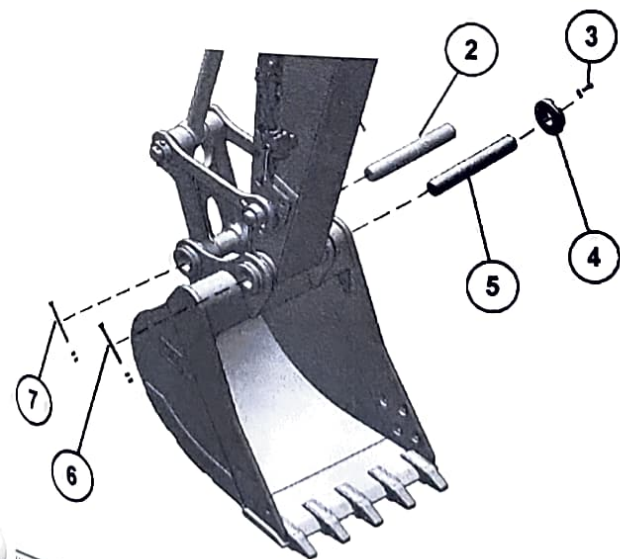

Illustration 260

g06186090

- Remove nuts and retaining bolt (7) from support pin (2). Remove the support pin.

- Remove bolts (3) and adapter plate (4). Remove the shims.
- Remove nuts and retaining bolt (6) from support pin (5). Remove the support pin.
- Start the engine and raise the stick out of the bucket.
- Remove the O-ring seals (1) from the flanges on the bucket.

**Note:** After the support pins have been removed, make sure that the support pins do not become contaminated with sand or dirt. Make sure that the seals on the end of the stick and the seals on the end of the link do not become damaged.

## Installation Procedure

- Clean each pin and each pin bore. Lubricate each pin bore with molybdenum grease.

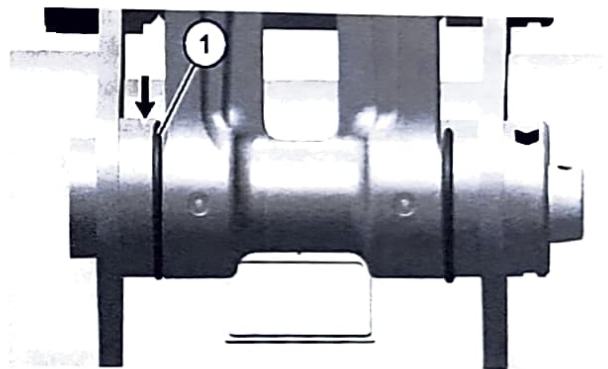

Illustration 261

g06192508

- Position the O-ring seals (1) onto the flanges of the bucket.
- Start the engine and lower the stick into the bucket until the pin bores are in alignment with each other. Stop the engine.



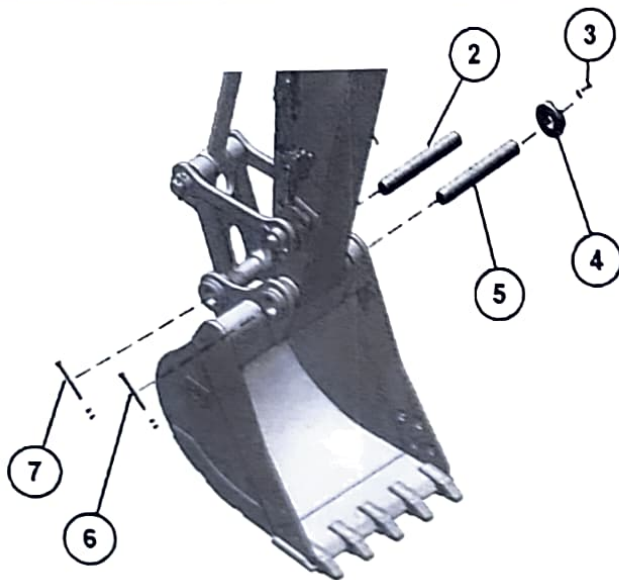

Illustration 262

g06186090

4. Install support pin (5). Align the retaining bolt hole in the support pin with the retaining bolt hole in the bucket.
5. Install the retaining bolt and nuts (6). Install adapter plate (4) without the shims, and without bolts (3) that hold the adapter plate.
6. Refer to Operation and Maintenance Manual, "Bucket Linkage - Inspect/Adjust" to adjust the bucket clearance.
7. Slide O-ring seals (1) in position over the pin joints between the bucket and the stick.
8. Start the engine and position the bucket linkage into the bucket until the pin bores are in alignment with each other. Stop the engine.
9. Install support pin (2). Align the retaining bolt hole in the bucket pin with the retaining bolt hole in the bucket.
10. Install retaining bolt and nuts (7).
11. Slide the O-ring seals (1) over the pin joints between the bucket and the link assembly.

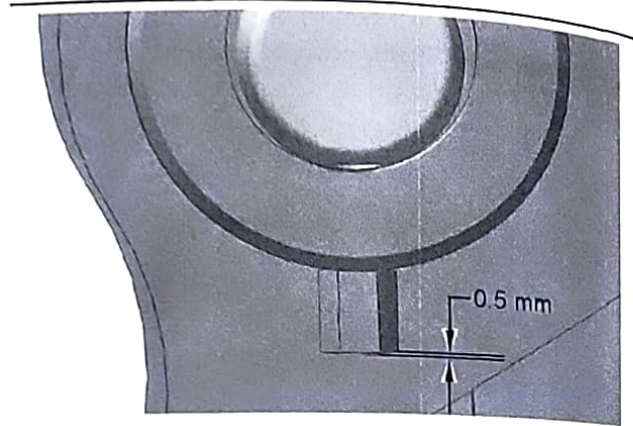

Illustration 263

g06192530

12. Tighten retaining nuts (6) and (7). Position the outside nut even with the end of the retaining bolt or 0.5 mm (0.02 inch) beyond the end of the retaining bolt. Tighten the inside nut against the outside nut.

13. Lubricate the bucket pins. Refer to Operation and Maintenance Manual, "Bucket Linkage - Lubricate".

107527138

## Work Tool Operation (If Equipped)

SMCS Code: 6700; 7000

### Hammer Operation (If Equipped)



Illustration 264

g06222793

**NOTICE**  
Use only a hydraulic hammer that is recommended by Caterpillar.

The use of a hydraulic hammer that is not recommended by Caterpillar could result in structural damage to the host machine.

Consult your Cat dealer for information on recommended hydraulic hammers.

Only use the hydraulic hammer to break rocks, concrete, and other hard objects. Before you start hydraulic hammer operation, place the machine on a level, stable surface.

Before you start hydraulic hammer operation, close the front window. Caterpillar recommends the installation of a window guard on the front window for protection from flying debris.

#### NOTICE

In order to avoid structural damage to the host machine or the hydraulic hammer, comply with the following:

Do not attempt to break rocks or concrete by burying the hammer tool completely into the rocks or concrete.

Do not apply a prying force to the hammer tool in order to remove the hammer tool from the material.

Do not allow the hydraulic hammer to operate at one location and for more than 15 seconds. Change the location of the hydraulic hammer and repeat the procedure. Failure to change the location of the hydraulic hammer could cause the hydraulic oil to overheat. Overheated hydraulic oil could damage the accumulator.

Stop the hydraulic hammer immediately if the jumper lines are pulsating violently. This indicates that the accumulator nitrogen charge is lost. Consult your Caterpillar dealer for the necessary repair.

#### NOTICE

Do not use the dropping force of the hydraulic hammer to break rocks or other hard objects. This could cause structural damage to the machine.

Do not use the sides or back of the hydraulic hammer to move rocks or other hard objects. Doing this could cause damage not only to the hammer but to stick or boom cylinder.

Do not operate the hydraulic hammer with any of the cylinders fully retracted or extended. Doing this could cause structural damage to the machine, resulting in reduced machine life.

Do not use the hydraulic hammer to lift an object.

Do not operate the hydraulic hammer while the stick is vertical to the ground. This could allow the stick cylinder to vibrate excessively.

Operate the attachment control levers carefully to keep the hydraulic hammer tool from hitting the boom.

Do not operate the hydraulic hammer under water unless the hydraulic hammer is properly equipped. Operating the hydraulic hammer under water could damage the machine hydraulic system. Consult your Caterpillar dealer for information on underwater operation.



Operation Section  
If Equipped

Do not operate the hydraulic hammer with the upper structure sideways to the undercarriage. Before you start hydraulic hammer operation, place the upper structure in the recommended positions that are shown in illustration 265 . Any other operating positions could make the machine unstable. Any other operating positions could place excessive loads on the undercarriage.

Refer to the following for any additional questions about the operation and care of your Caterpillar hydraulic hammer:

- Operation and Maintenance Manual, SEBU7346, "Hydraulic Hammers"
- The Operation and Maintenance Manual specific to your machine

An operation and maintenance decal, SMEU7397, is available for all hydraulic hammers. The decal provides procedures for operation and maintenance of the hydraulic hammers. The decal can be placed on the machine or the hammer. The decal can be obtained through the normal literature ordering channels.

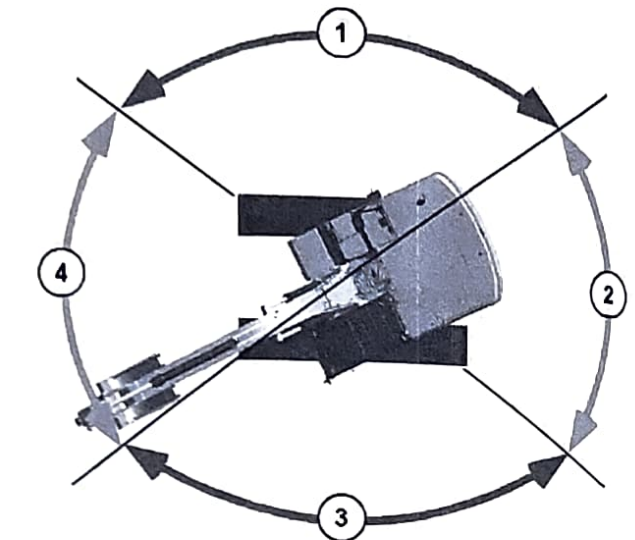

Illustration 265

g06192837

- (1) Incorrect working position
- (2) Correct working position
- (3) Incorrect working position
- (4) Correct working position

## Shear Operation (If Equipped)

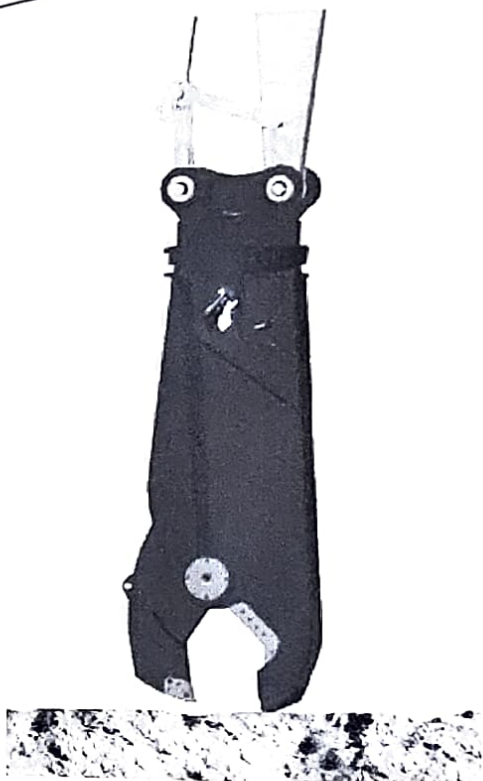

Illustration 266

g06222798

### **WARNING**

Do not operate or work on this work tool unless you have read and understand the instructions and warnings in the Operation And Maintenance Manual for both the work tool and the host machine.

Failure to follow the instructions or heed the warnings could result in injury or death.

Contact your Caterpillar dealer for replacement manuals. Proper care is your responsibility.

Selection of a hydraulic shear must be done with extra care.

Use of a hydraulic shear not recommended by Caterpillar could result in structural damage to the host machine.

Consult your Cat dealer for hydraulic shear information.

### NOTICE

### **WARNING**

Serious injury or death could occur from the demolition of pipes, vessels, tanks or other containers that may contain gas, flammable materials or hazardous chemicals.

Do not perform any demolition work on these items until all of their contents have been removed.

Follow all regulations for the removal and disposal of these materials.

### NOTICE

Using the demolition tool to level the work site or push over standing structures may damage the machine or the demolition tool. Use appropriate equipment to do site preparation or maintenance operations.

### NOTICE

To avoid structural damage to the machine, do not break road surfaces by placing the cutting edge of the hydraulic shear on the ground and moving the machine.

Be sure that no one is near the work tool to prevent injury. Keep the work tool under control at all times to prevent injury. When a demolition tool is used, all personnel must maintain a minimum distance of 10 m (33 ft).

Close all windows. Make sure that all required guards are in place. Wear all required protective equipment. Follow the instructions in the Operation and Maintenance Manual for the work tool.

i01582993

## Blade Operation

SMCS Code: 6060

### NOTICE

Avoid hitting or moving rocks using the blade. Blade and cylinder damage could occur.

When using the blade as outrigger, be sure to support the machine with the edge of the blade against the ground. When curling the front attachment, do not allow the bucket to hit the blade.

During digging operation, do not allow the boom cylinder to contact the blade edge. When no blade operation is needed, operate with the bucket on the opposite side of the machine from the blade.

Do not swing the upper structure with cab door and/or upper structure covers opened. An opened door and/or cover can hit the blade when the blade is in the raised position while the machine is swinging.



## Parking

i07311026

### Stopping the Machine

SMCS Code: 7000

#### WARNING

Leaving the machine unattended when the engine is running may result in personal injury or death. Before leaving the machine operator station, neutralize the travel controls, lower the work tools to the ground and deactivate all work tools, and place the lever for the hydraulic lockout control in the LOCKED position.

**Note:** There may be regulations that define the requirements for the operator and/or support personnel to be present when the engine is running.

Park on a level surface. If the machine must be parked on a grade, chock the tracks securely.

**Note:** The swing parking brake is automatically applied when the machine is stopped. The swing parking brake is released when the engine is running and the joystick is activated.

1. Turn the engine speed dial counterclockwise to reduce engine speed.



Illustration 267

g06181402

2. Release the travel levers/pedals to stop the machine.

3. Lower the work tool to the ground. Apply a slight downward pressure.
4. Move the hydraulic lockout control to the LOCKED position.

i07311032

### Freezing Conditions

SMCS Code: 7000

If freezing temperatures are expected, remove the mud and the dirt from each track roller frame. Park the machine on wood planks. Use the following procedure to clean each track roller frame.

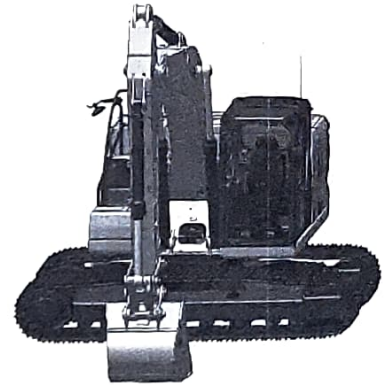

Illustration 268

g06188791

1. Position the boom over one side of the machine.
2. Use boom down pressure to lift the track on one side off the ground. Operate the track in the forward direction. Then operate the track in reverse. Continue this procedure until the maximum amount of material is thrown off the track.
3. Lower the track onto the wood planks.
4. Repeat the procedure for the other track.
5. Clean the area around the carrier rollers and around the track rollers.
6. Lower the work tool onto a wood plank to prevent the work tool from touching the ground.

i07527149

## Stopping the Engine

SMCS Code: 1000; 7000

### NOTICE

Stopping the engine immediately after it has been working under load can result in overheating and accelerated wear of engine components.

Refer to the following procedure to allow the engine to cool and to prevent excessive temperatures in the turbocharger housing, which could cause oil coking problems.

1. Stop the machine and lower the work tool to the ground.
2. Move the hydraulic lockout control to the LOCKED position.
3. Run the engine at low idle for 5 minutes.
4. Turn the engine start switch to the OFF position and remove the engine start switch key.

## Engine Stop Control

Turn the engine start switch to the OFF position. If the engine does not stop, perform the following procedure.

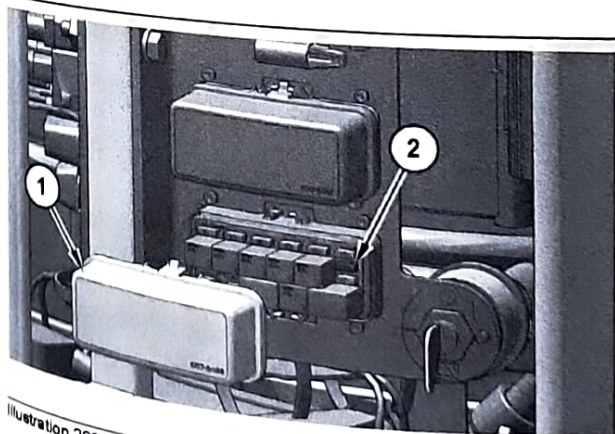

Illustration 269

g06350337

1. Open the access door on the right side of the machine.
2. Open the lower fuse cover (1) and remove fuse (2).

**Note:** Do not operate the machine again until the malfunction has been corrected.

3. Close the access door.

i07311066

## Leaving the Machine

SMCS Code: 7000



Illustration 270

g06278943

1. Use the steps and the hand holds when you dismount. When you dismount, face the machine and use both hands.
2. Inspect the engine compartment for debris. Clean out any debris to avoid a fire hazard.
3. Remove all flammable debris from the front bottom guard through the access doors to reduce a fire hazard. Discard the debris properly.
4. Always turn the battery disconnect switch to the OFF position before leaving the machine (if equipped).
5. If the machine will not be operated for a month or more, remove the battery disconnect switch key (if equipped).
6. Turn off all lights (courtesy lights will remain ON for set time).
7. Lock all compartments.

i07735115

## Machine Storage and Specified Storage Period

SMCS Code: 7000

### Machine Storage

The Safety Section of this Operation and Maintenance Manual contains storage information for fuels, lubricants, and ether (if equipped).