















Warning Displays

List of Warning Indicator Symbols

Symbol	Description	Illuminate/ Flash	Buzzer	Corrective Actions
	Engine trouble warning	Flash	Sound	Check the error code on the LCD monitor and contact your nearest dealer.
	Machine trouble warning			
	Engine stop request due to engine trouble	Illuminate	Sound	Contact your nearest dealer.
	DPF cleaning request	Flash	Sound	Contact your nearest dealer.
	Engine trouble caution	Illuminate	Sound	Contact your nearest dealer.
	DPF regeneration request or DPF cleaning request	Flash	Sound	If the lamp does not go out even by initiating a manual DPF regeneration, contact your nearest dealer.
	Low battery level	Flash	Sound	Stop the engine and perform inspection in accordance with the instructions described in "Troubleshooting" on page 207.
	Abnormal engine oil pressure	Flash	Sound	Stop the engine and perform inspection in accordance with the instructions described in "Troubleshooting" on page 207.
	Abnormal hydraulic oil temperature	Flash	Sound	Stop the operation and reduce the engine speed to lower the hydraulic oil temperature.
	Pre-filter problem	Flash	Sound	Stop the engine and perform inspection in accordance with the instructions described in "Checking and draining the pre-filter" on page 147.
	Air cleaner clogging	Flash	Sound	Stop the engine and perform inspection in accordance with the instructions described in "Checking and cleaning the air cleaner" on page 256.
	SCR system failure	Illuminate/ Flash	Sound	Contact your nearest dealer.
	Abnormal engine coolant temperature	Flash	Sound	Stop the engine and perform inspection in accordance with the instructions described in "Troubleshooting" on page 207.
	Low fuel level	Flash	No sound	Replenish fuel.
	Low urea level	Illuminate/ Flash	Sound	Replenish the urea tank.
	High exhaust gas temperature	Illuminate	No sound	This is a normal phenomenon. This symbol illuminates when the exhaust gas temperature becomes high during DPF regeneration. Make sure that there are no people or flammable objects in the vicinity of the exhaust pipe.
	DPF manual regeneration request	Illuminate	No sound	This is a normal phenomenon. This symbol illuminates when the amount of PM (Particulate Matter) accumulation has reached the prescribed value. Perform manual regeneration in accordance with the instructions described in "DPF manual regeneration" on page 181.
	DPF manual regeneration permitted	Flash	No sound	This is a normal phenomenon. This symbol flashes when DPF manual regeneration can be initiated.
	DPF manual regeneration initiated	Illuminate	No sound	This is a normal phenomenon. This symbol illuminates when the manual regeneration switch is pressed and held down with the DPF manual regeneration request symbol illuminated.

OPERATION

1. Identification of Important Parts	81	3.2 Starting up the engine	152
1.1 Overview of the machine	81	3.3 Operating and checking instructions after starting the engine	155
1.2 Controls and switches	82	3.4 Traveling	157
2. Description of Control Devices	83	3.5 Steering	159
2.1 LCD monitor.....	83	3.6 Stopping the machine	161
2.2 Switches	101	3.7 Dumping the wagon	162
2.3 Control levers	107	3.8 Swinging the wagon (for the swing wagon type)	163
2.4 Engine hood.....	111	3.9 Precautions for working	164
2.5 Side cover	112	3.10 Precautions for going up and down a slope	165
2.6 Battery cover	112	3.11 Parking the machine	167
2.7 Urea tank cover	113	3.12 Checks required after operation ...	168
2.8 Cabin.....	114	3.13 Stopping the engine	168
2.9 Fuse box	119	3.14 Inspection requirements after stopping the engine	169
2.10 Fuel supply port cap	121	3.15 Locking	169
2.11 Urea filler cap	121	3.16 Handling the rubber crawlers	170
2.12 Operator's seat	122	3.17 Removal of wagon flaps	176
2.13 Grease gun holder	124	3.18 Handling diesel particulate filter (DPF)	177
2.14 Storage pocket for the operation & maintenance manual	124	3.19 Handling the Urea SCR system ...	184
2.15 Tool storage space	124	4. Transportation	186
2.16 Wagon stopper	125	4.1 Loading and unloading the machine	186
2.17 Handling air conditioner (Option for cabin)	126	4.2 Suspending the machine	188
3. Operating Instructions	135		
3.1 Checking before starting the engine	135		

4.3	Precautions for loading the machine	190
4.4	Precautions for transporting the machine	191
5.	Care and Service in Cold Weather	192
5.1	Preparing for cold weather	192
5.2	Precautions after a day's work	195
5.3	After cold weather ends	195
6.	Long-term Storage	196
6.1	Before storing	196
6.2	Storing	198
6.3	Using the machine again	198
7.	Troubleshooting	199
7.1	Phenomena that do not constitute faults	199
7.2	Towing	200
7.3	Precautions in special work sites ...	201
7.4	If the battery is overdischarged ...	202
7.5	Troubleshooting	207
8.	Handling the Engine	210
8.1	Prohibited acts	210
8.2	Cautions	210
8.3	Diesel fuel	210
9.	Limitations on Power Output by Inducement when an SCR System Failure occurs	211
10.	Limitations on Power Output by Inducement resulting from Low Level in the Urea Tank ...	213

1. Identification of Important Parts

1.1 Overview of the machine

The directions are as indicated by the arrows in the figure below.

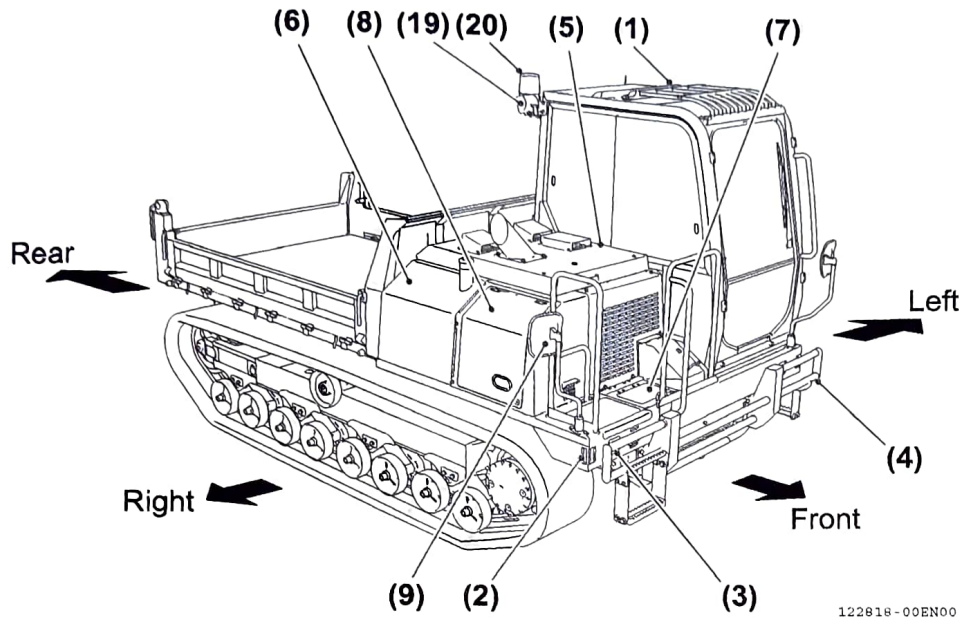

122818-00EN00

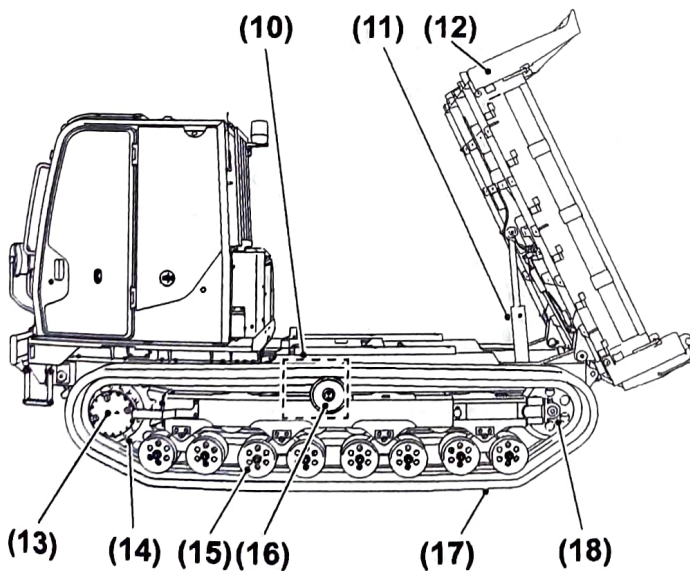

122819-00X00

- (1) Cabin
- (2) Flasher
- (3) Headlight
- (4) Bumper
- (5) Engine hood
- (6) Fuel tank
- (7) Battery cover
- (8) Side cover
- (9) Rearview mirror
- (10) Hydraulic oil tank
- (11) Dump cylinder
- (12) Wagon
- (13) Reduction gear
- (14) Sprocket
- (15) Track roller
- (16) Carrier roller
- (17) Rubber crawler
- (18) Idler
- (19) Working lamp (Option)
- (20) Beacon lamp (Option)

1.2 Controls and switches

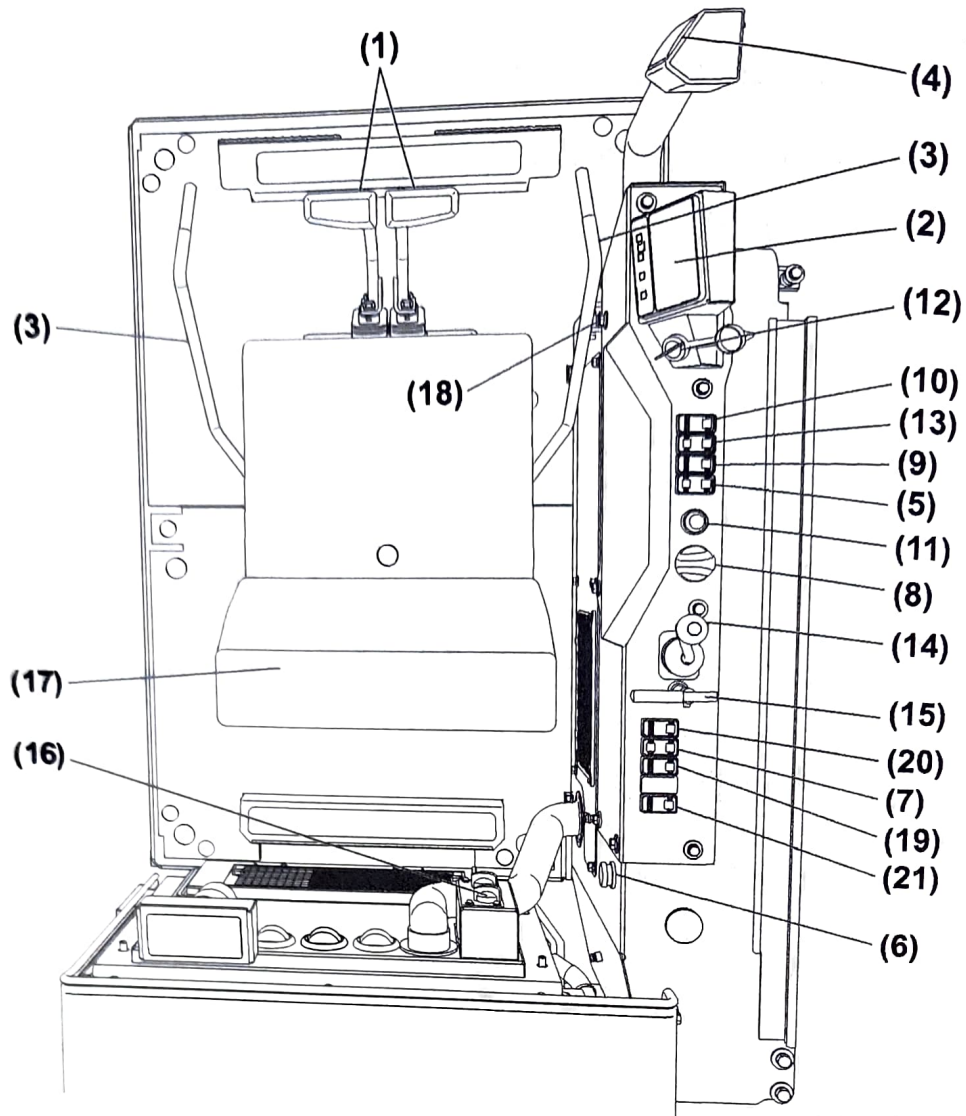

- | | |
|---|---|
| (1) Travel levers | (16) Air conditioner (Option for cabin) |
| (2) LCD monitor | (17) Operator's seat |
| (3) Lock lever
(Operator's seat reverse lever) | (18) Engine stop switch |
| (4) Defroster (Option for cabin) | (19) Beacon lamp switch (Option) |
| (5) Turn signal switch | (20) DPF manual regeneration switch |
| (6) Power socket (12V) | (21) Rear wiper switch (for cabin) |
| (7) Heater switch (Option for cabin) | |
| (8) Accelerator dial | |
| (9) Windshield wiper switch (for cabin) | |
| (10) Light switch | |
| (11) Horn switch | |
| (12) Starter switch | |
| (13) Travel speed change switch | |
| (14) Dump lever | |
| (15) Dump lock lever | |

2. Description of Control Devices

This section describes several of the control devices necessary to operate the machine. In order to ensure safety and comfort in working with the machine, it is imperative for you to fully understand how to operate and interact with these devices.

2.1 LCD monitor

Main Screen

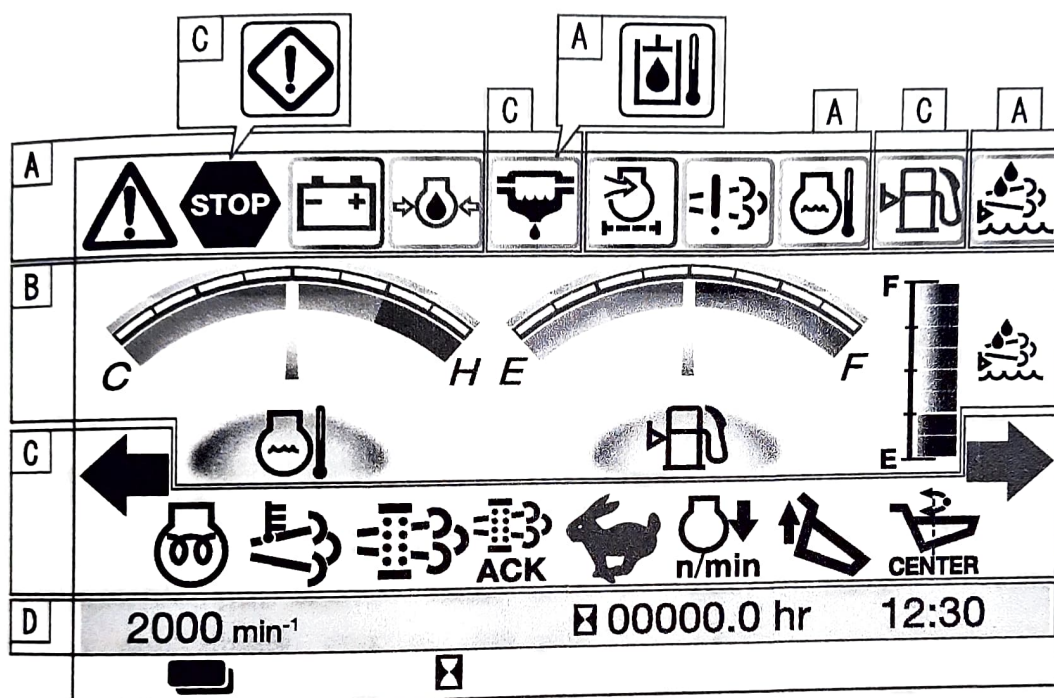

AS96C04

IMPORTANT

For start-up inspection, be sure to refer to PART THREE: MAINTENANCE, or Section "3. Operating Instructions" on page 135 as well as the monitor messages as shown above.

(A) Emergency stop Items

Attention must be paid to these items while the engine is running. The item requiring treatment would be displayed immediately. When there is any failure, the alarm lamps light or flash and a buzzer sounds.

(B) Meters

These indicate the coolant temperature for the engine and the fuel amount in the fuel tank.

(C) Indicator lamps

These lamps indicate engine trouble caution, pre-filter warning, fuel level warning, turn signals, the state of engine preheating, exhaust gas temperature warning, DPF regeneration request, DPF regeneration permit, travel speed, deceleration, the state of the wagon being raised or lowered and the swing state of the wagon (for the swing wagon type).

(D) Other indicators

The LCD monitor also displays an hour meter or trip meter, engine speed and clock.

(A) Emergency stop items

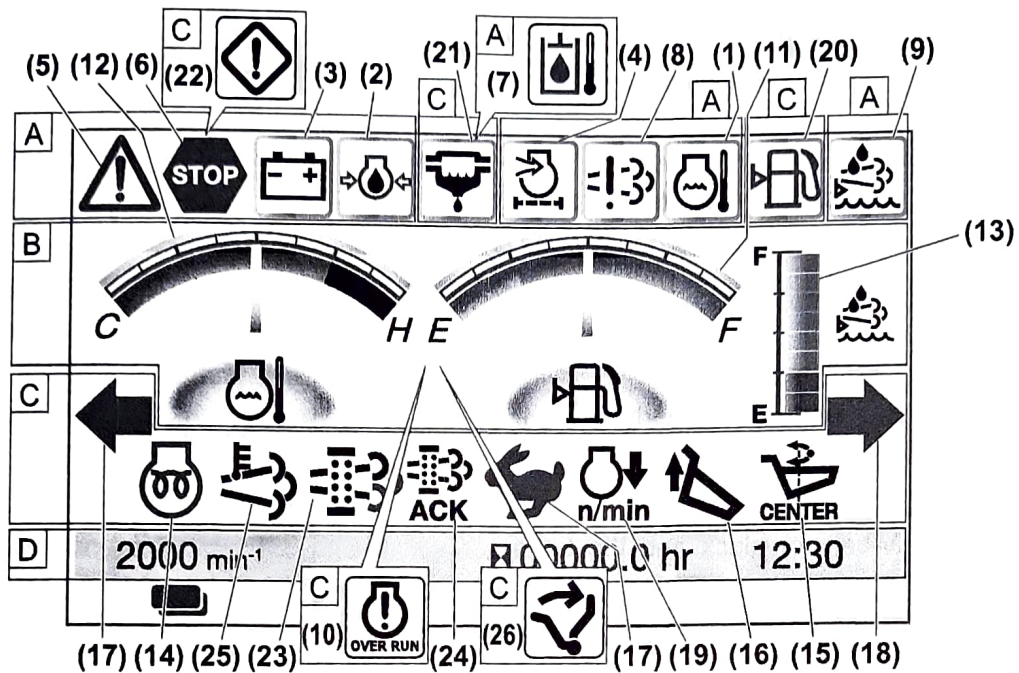

122821-00EN00

⚠ WARNING

When an indicator lamp lights and a buzzer sounds during operation, immediately stop operation and check and service the abnormality.

(1) Water temp. alarm lamp

When the coolant temperature rises abnormally during operation, the alarm lamp will flash and the buzzer will sound. Idle the engine at low speed for a while, and stop it. After the engine has cooled, take corrective actions by referring to Section "7.5 Troubleshooting" on page 207.

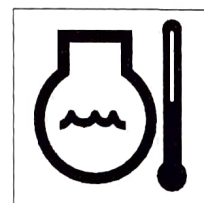

AS8B006

Note:

The alarm lamp will illuminate for approximately 2 seconds after the starter switch is turned to the ON position with the engine stopped. This is a normal phenomenon.

(2) Engine oil pressure alarm lamp

If engine oil pressure falls below the normal level, the alarm lamp will flash and the buzzer will sound. In this event, stop the engine and inspect it according to Section "7.5 Troubleshooting" on page 207.

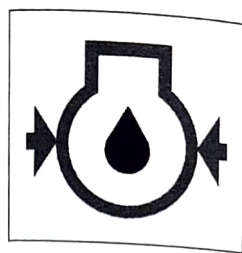

AS8B007

Note:

The alarm lamp will flash while the starter switch is in the ON position with the engine stopped. This is a normal phenomenon.

(3) Battery charge alarm lamp

If the battery is not charged properly while the engine is running, the alarm lamp will flash and the buzzer will sound. In this event, stop the engine and inspect the V-belt for slack and the battery charging circuit. If you find something abnormal with it, take corrective action by referring to Section "7.5 Troubleshooting" on page 207.

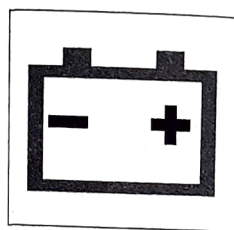

AS8B008

Note:

The alarm lamp will flash while the starter switch is in the ON position with the engine stopped. This is a normal phenomenon.

(4) Air cleaner alarm lamp

If the air cleaner filter is clogged while the engine is running, the alarm lamp will flash and the buzzer will sound. Stop the engine and clean the filter of the air cleaner.

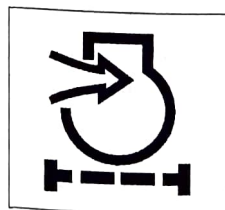

AS8B009

Note:

The alarm lamp will illuminate for approximately 2 seconds after the starter switch is turned to the ON position with the engine stopped. This is a normal phenomenon.

(5) Machine/engine trouble alarm lamp

If the controller detects a machine or engine failure with the starter switch in the ON position, the alarm lamp will light or flash and the buzzer will sound. In such a case, refer to "Machine Error Codes" on page 296 or "Engine Error Codes" on page 297 and contact your dealer for assistance.

Note:

The alarm lamp will illuminate for approximately 2 seconds after the starter switch is turned to the ON position with the engine stopped. This is a normal phenomenon.



AS8B010

(6) Engine stop request lamp

If a serious engine failure occurs with the starter switch in the ON position and the engine needs to be stopped immediately, this lamp will illuminate and the buzzer will sound. When this lamp illuminates, stop the engine immediately and check and repair the defective part.

In addition, if the DPF needs to be cleaned, this request lamp will flash. When this lamp flashes, contact your nearest dealer for assistance.



AS9B007

(7) Hydraulic oil temp. warning lamp

This lamp will flash and the buzzer will sound when the hydraulic oil temperature rises abnormally while the engine is running.

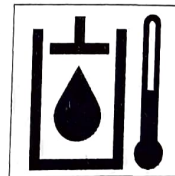

AS9B008

(8) SCR system warning lamp

This lamp will illuminate, or flash and the buzzer will sound when an SCR System failure is detected (e.g. Inability to properly inject aqueous urea solution, degraded aqueous urea solution quality) while the engine is running.

If this warning lamp is illuminated or flashing, the SCR system needs to be repaired to correct the failure. Contact your dealer for assistance.

For more information about the warning lamp illuminated or flashing, refer to "9. Limitations on Power Output by Inducement when an SCR System Failure occurs" on page 211.

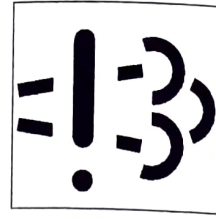

AS9B009

(9) Urea level warning lamp

This lamp will illuminate, or flash and the buzzer will sound when the aqueous urea solution level is low.

1.Illumination

The warning lamp will illuminate when the urea level meter reads 10% or less. No limitations will apply to the engine speed or the amount of fuel injected. However, aqueous urea solution should be replenished without delay.

2.Flashing

The warning lamp will flash when the urea level meter reads 0%, and the amount of fuel injected will be limited to 75%. In addition, if there is no aqueous urea solution remaining in the urea tank (i.e. No aqueous urea solution is available for use), the engine speed will be limited to low idle and the amount of fuel injected to 50%. In such cases, aqueous urea solution should be replenished without delay.



AS9B010

(10) Overrun warning Indicator

When the engine speed becomes too high, "OVERRUN" will be displayed on the LCD monitor as shown in the figure on the right and the buzzer will sound intermittently. If the engine speed increases further, the intermittent buzzer tone will become constant.

The most likely causes of engine overrun are the machine traveling down a slope at high speed or with excessive load.

If this indicator appears, stop the machine and follow the instructions below.

- Travel downhill after moving to a low-gradient slope area.
- Operate the travel levers to keep speed down.
- Travel with the accelerator dial at half throttle or less.
- If the problem is excessive load, reduce the load before traveling.

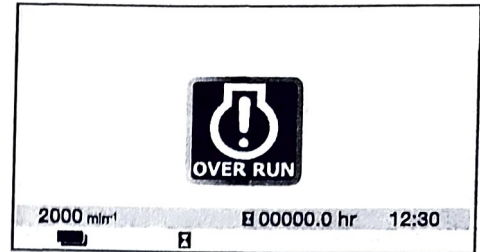

AS9B011

(B) Meters

(11) Fuel meter

This indicates the fuel amount in the fuel tank. When the meter pointer indicates close to E (empty) during operation, refill fuel tank soon.

All zones of the meter will illuminate for approximately 2 seconds after the starter switch is turned to the ON position with the engine stopped. This is a normal phenomenon.

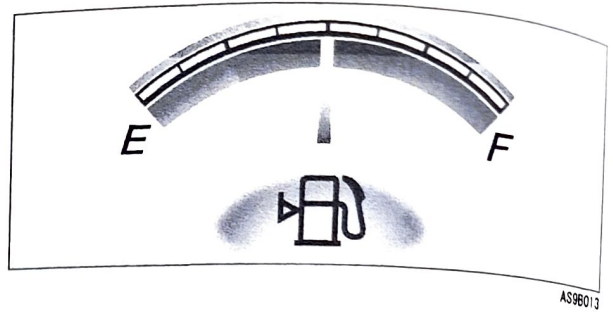

(12) Water temp. meter

This indicates the coolant temperature for the engine.

The green zone of the meter illuminates during the normal operation of the engine.

If the red zone of the meter illuminates during engine operation, reduce the engine speed to low idle and continue to run the engine at low idle until the coolant temperature drops and the green zone of the meter illuminates. Then, stop the engine and inspect it after the engine has cooled down.

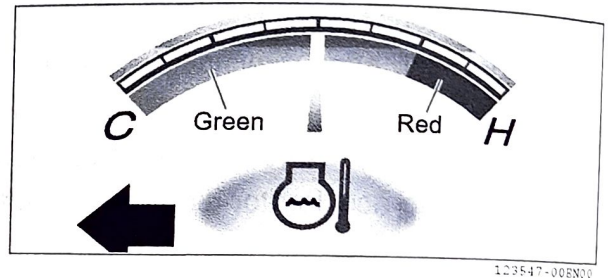

Note:

All zones of the meter will illuminate for approximately 2 seconds after the starter switch is turned to the ON position with the engine stopped. This is a normal phenomenon.

(13) Urea level meter

This meter indicates the urea level in the urea tank.

When the meter pointer comes close to the E (empty) level during operation, refill the urea tank as soon as possible.

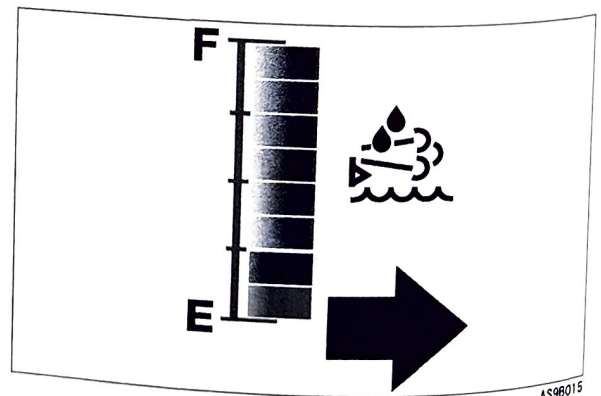

(C) Indicator lamps**(14) Glow lamp**

This lamp indicates the time required to preheat the engine when starting the engine in cold weather. The indicator lamp lights up when preheating starts and goes off in a few seconds to indicate the completion of preheating.

The preheating time varies depending on the coolant temperature.

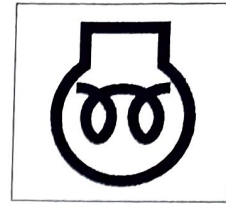

AS8B016

**(15) Wagon center indicating lamp
(for the swing wagon type)**

The indicator lamp lights when the wagon is in parallel to the crawlers and goes off when it swings to the right or the left.

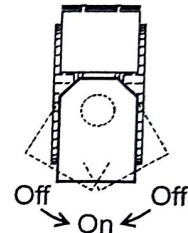

AS8B017E

(16) Wagon-up indicator lamp

The indicator lamp lights up when the wagon is raised and goes out of contact with the switch and goes off when the wagon is lowered all the way.

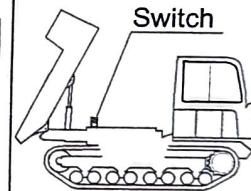
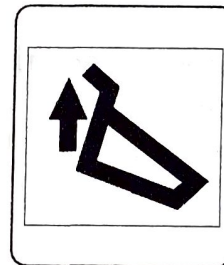

AS8B018E

(17) Travel speed indicator lamp

The indicator lamp lights up when the travel speed change switch is set to high speed and goes off when the switch is set to low speed.

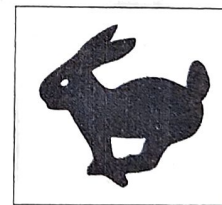

AS8B019

Note:

When a pivot turn is made or when a load applied to the travel motors increases with the travel speed change switch in the high-speed position, the travel speed is switched to low speed but the indicator lamp remains on.

(18) Turn signal

When a turn signal is activated by the turn signal switch, the corresponding turn signal flashes.

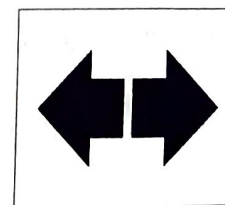

12354B-00X00

(19) Deceleration indicator lamp

The indicator lamp lights up and the engine speed is reduced to low idle (1200 RPM) when the lock lever is placed in the lock position.

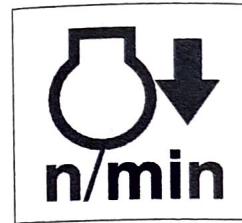

AS8B021

(20) Fuel level warning lamp

With the starter switch in the ON position, the warning lamp flashes when the amount of fuel remaining in the tank is less than 20.9L.

If the lamp flashes, check the fuel level in the tank and replenish fuel.

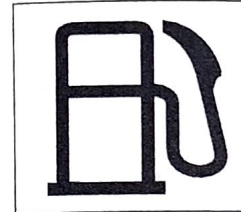

AS8B022

(21) Pre-filter warning lamp

With the starter switch in the ON position, the alarm will sound and the warning lamp will flash when water is detected in the pre-filter.



AS8B013

Note:

The warning lamp will illuminate for approximately 2 seconds after the starter switch is turned to the ON position with the engine stopped. This is a normal phenomenon.

(22) Engine trouble caution lamp

With the starter switch in the ON position, the alarm will sound and the caution lamp will light up when the engine controller detects engine problems. If the caution lamp illuminates, contact your dealer for assistance.

With the starter switch in the ON position, the caution lamp will flash when a DPF regeneration or cleaning is requested. If the caution lamp does not go off even after a manual DPF regeneration is started, contact your dealer for assistance.



AS8B011

Note:

The caution lamp will illuminate for approximately 2 seconds after the starter switch is turned to the ON position with the engine stopped. This is a normal phenomenon.

(23) DPF regeneration request lamp

The request lamp lights up when a certain amount of particulate matter (PM) has accumulated during engine operation. If the lamp lights up, immediately perform a DPF regeneration according to the procedure described in "DPF manual regeneration" on page 181. The lamp will go off when a manual DPF regeneration is started.

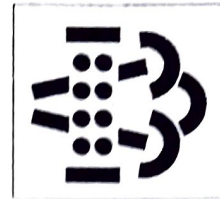

AS8B012

Note:

The request lamp will illuminate for approximately 2 seconds after the starter switch is turned to the ON position with the engine stopped. This is a normal phenomenon.

(24) DPF regeneration permit lamp

The permit lamp flashes in a standby status in which a manual DPF regeneration is ready to be performed. The lamp illuminates when a manual DPF regeneration is started and goes off when the regeneration is complete.



AS8B024

Note:

The permit lamp will illuminate for approximately 2 seconds after the starter switch is turned to the ON position with the engine stopped. This is a normal phenomenon.

(25) Exhaust gas temp. warning lamp

The warning lamp stays on, indicating that the exhaust gas temperature is high, while an automatic or manual DPF regeneration is underway. The lamp will go off when the DPF regeneration is complete.

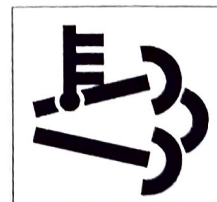

AS8B025

Note:

The warning lamp will illuminate for approximately 2 seconds after the starter switch is turned to the ON position with the engine stopped. This is a normal phenomenon.

(26) Safe start warning Indicator

If the operator attempts to start the engine with the lock levers in the unlock position, an enlargement of this indicator will be displayed on the LCD monitor and the buzzer sounded. This will make it impossible to start the engine. In such cases, set the lock levers to the lock position before starting the engine.

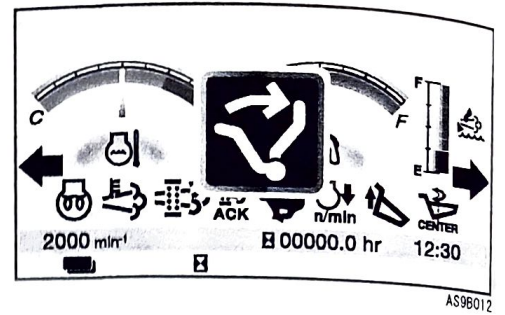

AS96012

(D) Other indicators

When the starter switch is turned to the ON position, the LCD monitor displays an hour meter/trip meter, engine speed and clock.

Screen operation keys

Button (B) (hour meter key) is used to switch between the hour meter and the trip meter. To display the Menu screen, press button (A) (menu key).

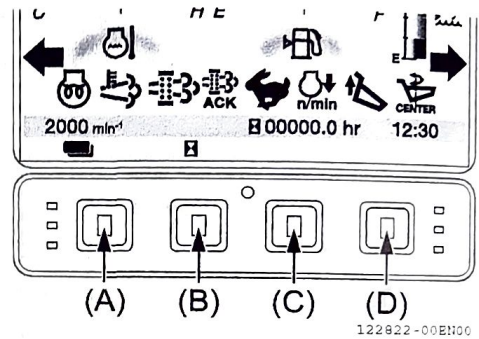

122822-00EN00



■ Trip mode display

Each time button (B) is pressed, the current display is switched in the order shown in the table below. Whenever the starter switch is turned to the ON position, the hour meter is displayed.

Order	Display	Name	Description
1		Hour meter	The hour meter shows hours of operation of the machine in hours and tenths of hours. Periodic maintenance intervals for the machine should be set by making use of values displayed on the hour meter. While the engine is running, the hour meter continues to accumulate hours even if the machine is not being operated.
2		Trip meter 1	Trip meter 1 shows the accumulated operating hours of the machine since the meter was last reset. To reset the trip meter to 0, press and hold button (B) for 3 seconds with trip meter 1 shown on the screen.
3		Trip meter 2	Trip meter 2 shows the accumulated operating hours of the machine since the meter was last reset. To reset the trip meter to 0, press and hold button (B) for 3 seconds with trip meter 2 shown on the screen.
4		Trip meter 3	Trip meter 3 shows the accumulated operating hours of the machine since the meter was last reset. To reset the trip meter to 0, press and hold button (B) for 3 seconds with trip meter 3 shown on the screen.

■ Display of engine speed and clock

When the starter switch is turned to the ON position, the LCD monitor also displays the engine speed and clock.

Order	Display	Name	Description
1		Engine speed	The speed at which the engine is rotating is displayed.
2		Clock	The clock shows the time.

Menu Screen

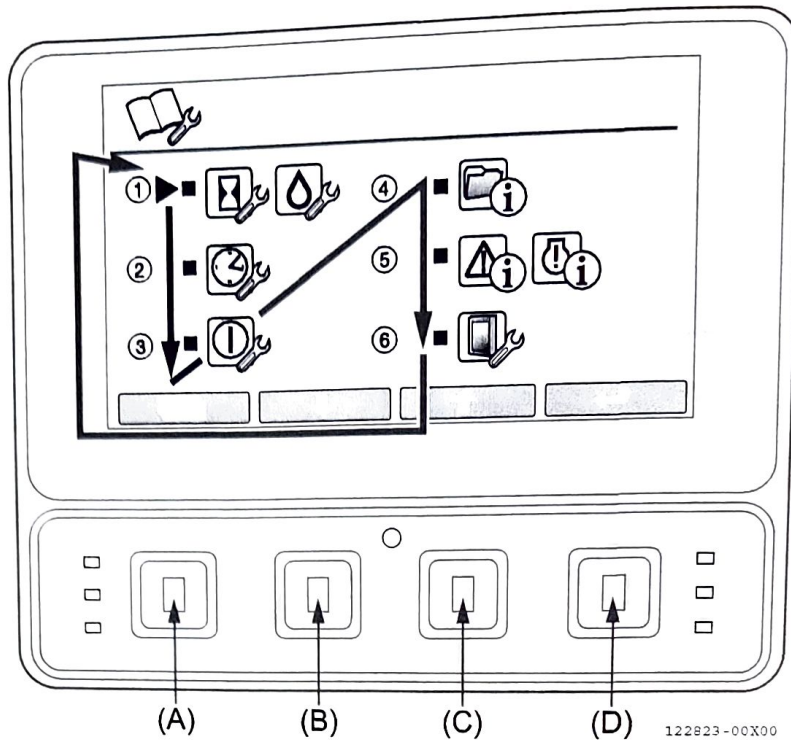

With the Main screen displayed, press menu key (A) to switch to the Menu screen.

- ① Trip meter setting
- ② Time setting
- ③ Function setting
- ④ Data display
- ⑤ Error code display
- ⑥ Monitor settings

Use down arrow (↓) key (B) and up arrow (↑) key (C) to move the cursor (▶) to the desired item and then press enter key (D) to make settings. To return to the Menu screen, press menu key (A). The wrench symbol means that the setting can be changed and the (i) symbol means that only information is provided.

Screen operation keys

A. Menu key

This key is used to switch between the Main screen and the Menu screen. In addition, pressing this key will cancel the setting when making a setting. Pressing this key with the Menu screen displayed will return to the Main screen.

B. Down arrow (↓) key

This key is used to move the cursor (▶) down on each setting screen and also to decrease the number displayed. Pressing and holding this key for one second will decrease the number quickly.

C. Up arrow (↑) key

This key is used to move the cursor (▶) up on each setting screen and also to increase the number displayed. Pressing and holding this key for one second will increase the number quickly.

D. Enter key

This key is used to save or execute settings or changes made by the keys. Pressing and holding this key for three seconds with a trip meter displayed will clear the trip meter.

① Trip meter setting

Six patterns of hours of operation can be set as desired.

To display the Menu screen, press the menu key.
To clear a trip meter, use the up allow (↓) or down arrow (↓) key to move the cursor (▶) to the trip meter, which will flash, and then press and hold the enter key for three seconds.

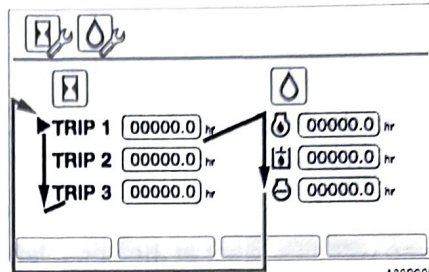

A39B025

② Timer setting

The time can be set.

Press the enter key and enter the number of hours.
(During the editing session, the number will flash.)
Press the enter key to save the number. In the same way, set the number of minutes.

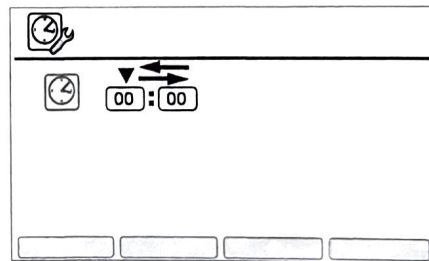

A39B025

③ Function setting

Either the back-up alarm or the travel alarm can be selected.

Move the cursor (▶) to the desired selection and press the enter key to finalize.

- Back-up alarm

An alarm sounds continuously when the machine is making a spin turn or traveling in reverse.

- Travel alarm

An alarm sounds continuously when the machine is traveling.

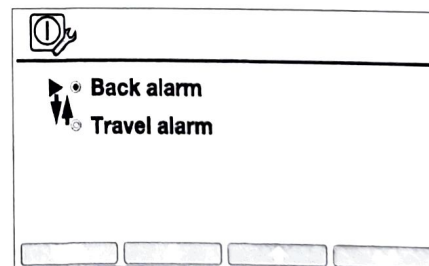

A39B058

④ Data display

Different types of data are displayed. The settings cannot be changed.

Display items are as follows:

- Engine speed
- Coolant temperature
- Hydraulic oil temperature
- Battery voltage
- PM accumulation rate
- Ash accumulation rate

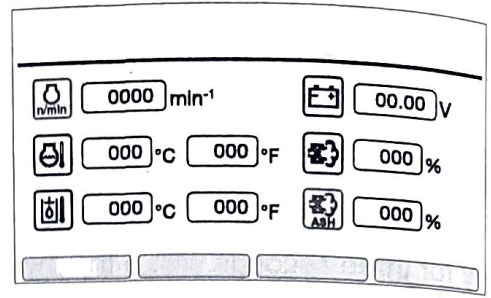

AS9B027

⑤ Error code display

▲ Machine error code

A maximum of four machine error codes can be displayed with the latest at the upper left.

For details, see "7. Machine error codes" on page 296.

⚠ ECM error code

Press the CLEAR key to delete the codes of errors that have already been resolved from the monitor and update the display.

A maximum of three EMC (Engine Control Module) error codes can be displayed with the latest one at the top.

For details, see "8. Engine error codes" on page 297.

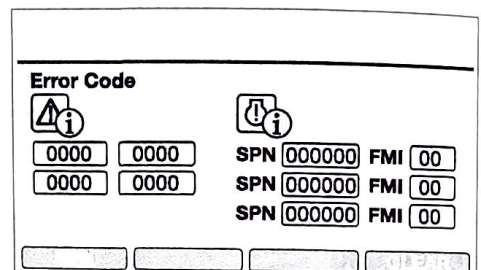

AS9B028

IMPORTANT

If an error code is displayed, immediately stop the operation and contact your nearest dealer for service.

⑥ Monitor settings

Display settings can be changed.

Use the up arrow (↑) and down arrow (↓) keys to move the cursor (▶).

When the cursor (▶) has reached the desired setting item, press the enter key to finalize.

To display the Menu screen, press the menu key.

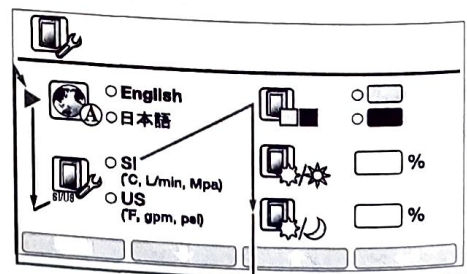

AS9B029

● **Language**

This machine is not provided with a language switching function.

Note:

Although the other language that is not the factory default setting can be selected on this setting screen, the language selected will not be reflected and the language displayed will not be changed.

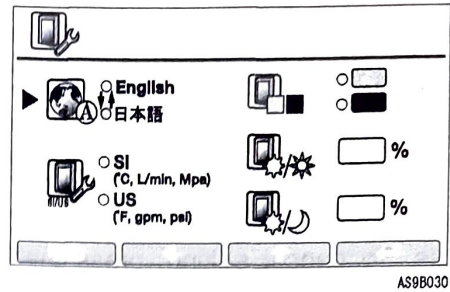

AS9B030

● **Unit setting**

This machine is not provided with a unit setting function.

Note:

Although the other unit that is not the factory default setting can be selected on this setting screen, the unit selected will not be reflected and the unit displayed will not be changed.

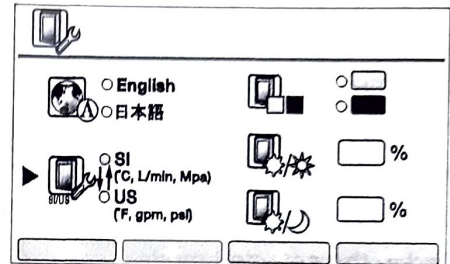

AS9B031

● **Background color setting**

The background color can be changed.

Move the blue flashing light to the position of the desired color and press the enter key to finalize.

The color can be changed on this screen regardless of whether it is daytime or nighttime.

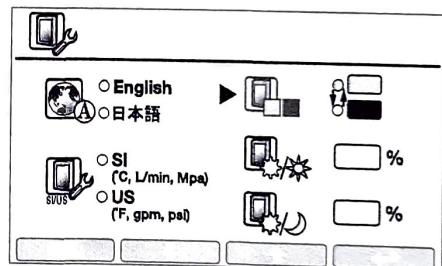

AS9B032

● **Brightness setting**

The LCD brightness can be adjusted (Setting range: 0% to 100%).

Move the cursor (▶) to the desired brightness setting symbol and press the enter key. The numerical value will flash to indicate that editing is possible. To cancel editing, press the menu key during the editing session.

Use the up arrow (↑) and down arrow (↓) keys to change the numerical value to the desired value and press the enter key to end the editing session.

(1) Daytime mode: Initial value: 100%

(2) Nighttime mode: Initial value: 50%

Adjustments made to the nighttime mode with the daytime mode selected, or to the daytime mode with the nighttime mode selected will not be reflected in the selected mode.

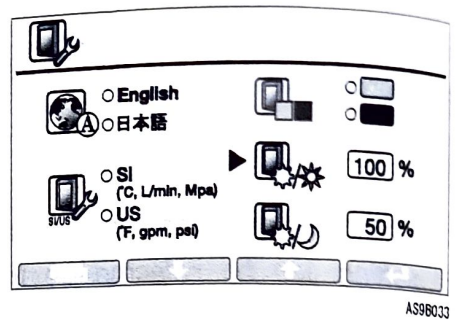

2.2 Switches

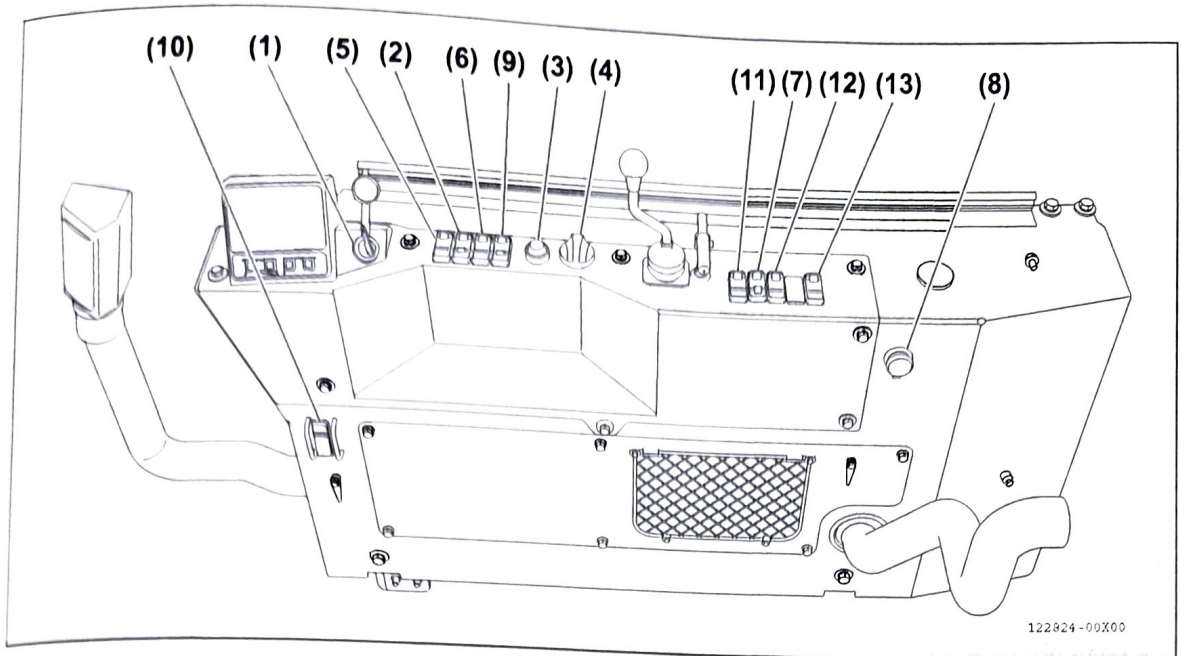

(1) Starter switch

Use this switch to start and stop the engine.

Cover the starter switch with a waterproof cover when the starter switch key is removed.

- OFF position

Turn the starter switch key to "OFF" to stop the engine and disconnect electrical circuit or remove the starter switch key.

- ON position

Turn the starter switch key to "ON" to connect the electrical fuel solenoid circuit, the electrical charging circuit and the lamp circuit. (Keep the starter switch key in this position while running the engine.)

When the coolant temperature is low, the glow lamp will turn on and the engine preheating process starts automatically.

As soon as the glow lamp turns OFF, turn the starter key into the "START" position to start up the engine.

- START position

Turn the starter switch key to "START" to start the engine. Release the starter switch key after the engine is started and it will return to the "ON" position.

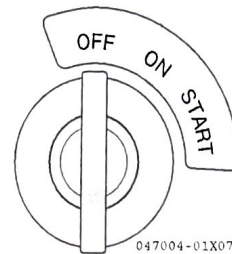



(2) Travel speed change switch

⚠ WARNING

When the load exceeds the specified level while the machine is traveling at high-speed, the travel speed of the machine is automatically switched to the low-speed. When the load becomes lighter, the travel speed is automatically returned to the high-speed. Be careful in traveling with the machine as the travel speed changes depending on the load condition.

Press the switch button down to switch between the automatic speed change and the fixed low speed.

- : Automatic speed change between high and low speed
- : Fixed low speed

(3) Horn switch

A horn sounds by pressing the horn switch regardless of the position of the starter switch key.

(4) Accelerator dial

This dial controls and maintain the engine speed and output to a constant level.

- [1] Low idling: Turn the dial fully counterclockwise.
- [2] High idling: Turn the dial fully clockwise.

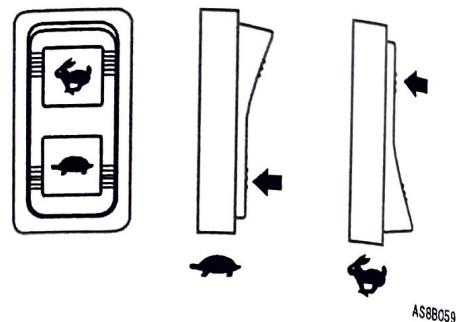

AS8B059

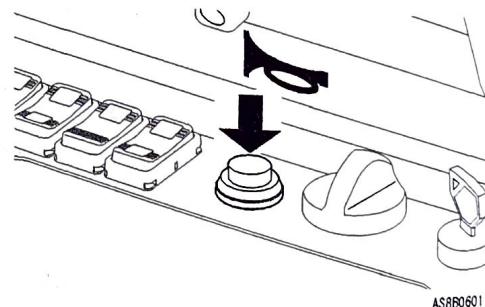

AS8B0601

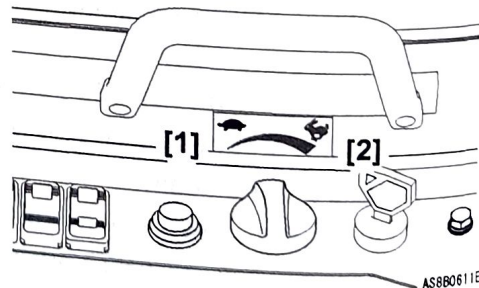

AS8B0611E

(5) Light switch

It operates when the starter switch is in the "ON" position. The headlights and the switch lamps go on.

- ON: The switch lamps, headlights and LCD backlight (option) go on.
- OFF: The lights go off.

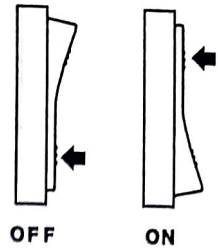

A58B062

IMPORTANT

Do not keep the lamps on for a long time while the engine is not running. The battery will run down and the engine may not start.

(6) Windshield wiper switch (for cabin)

This switch can be used with the starter switch in the ON position.

- PUSH: Press the switch down to this position to spray washer fluid.
- ON: Set the switch to this position to operate the windshield wiper.
- OFF: Set the switch to this position to stop the windshield wiper.

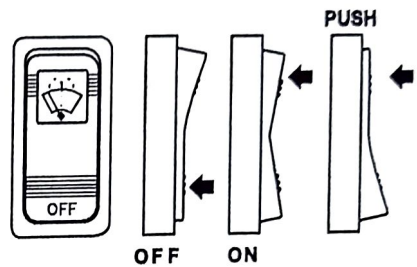



A32B063-01

IMPORTANT

- Do not use the wiper switch when washer fluid will not spray. Doing so may cause pump failure.
- Wiping a dry windshield could damage the glass. Be sure to first spray water or washer fluid onto the glass and then operate the wiper.
- The wiper blade may freeze to the glass in cold weather. Do not attempt to operate the frozen wiper. Doing so may cause damage to the wiper motor.

(7) Heater switch (Option for cabin)

Use this switch to warm up the air in the cabin or canopy. Move the switch to set the fan speed at either of the two levels.

- : Low fan speed.
- : High fan speed.
- OFF: Fan stops.

Operate the heater switch after the coolant has warmed up.

Open and close the circulation valve (1) for the coolant at the beginning and the end of the season when the heater is used, respectively.

Inner and outer air switching lever

This lever (2) is used to switch between outer air induction and inner air circulation.

 ... Outer air induction:

Use this position to induce the fresh air from outside or to defrost the windshield.

 ... Inner air circulation:

Use this position to heat the cabin in a short time or when the outside air is dirty.

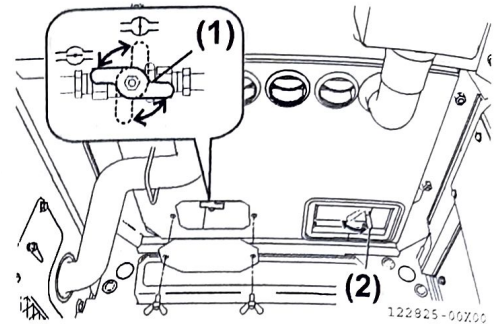
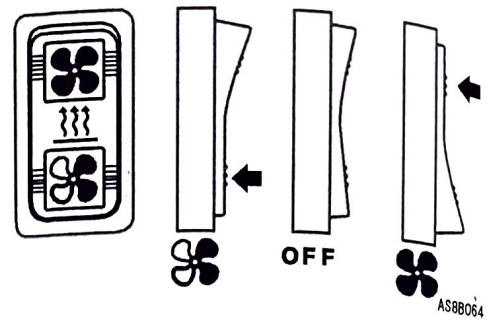

(8) External power socket

⚠ WARNING

Be sure to use only electrical products which comply with the specifications of this power socket.

This socket is intended as a power outlet. Be careful not to exceed 12V/10A when using this socket. To use this socket, open the cap (1).

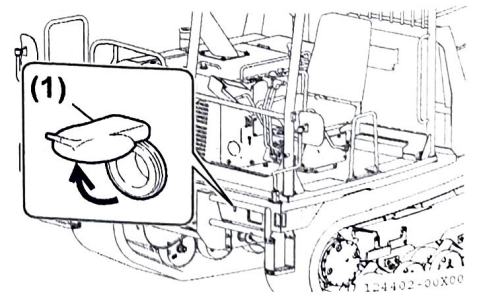
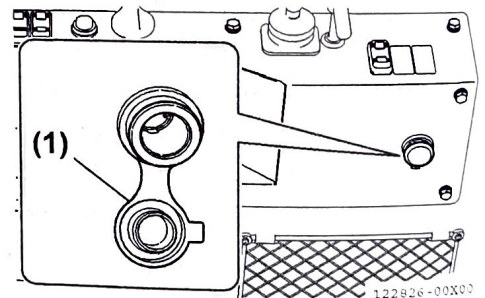

(9) Turn signal switch

It operates when the starter switch is in the "ON" position.

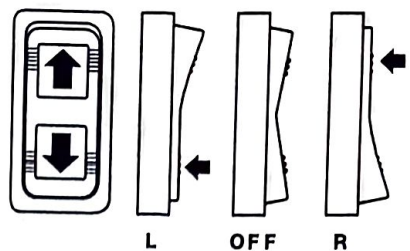

Press the L side of the switch to make the left-hand flasher lamp to flash and the R side to make the right-hand flasher lamp to flash.



AS8B0661

(10) Engine stop switch

If the engine is not stopped by turning the starter switch to the "OFF" position due to mechanical failure or breakage, use this switch to stop the engine.

- : Engine stop
- : Normal operation

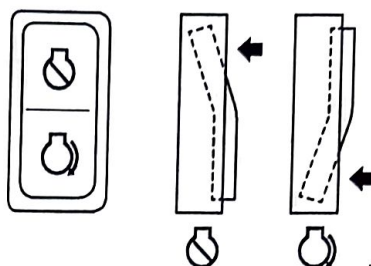

AS8B0571

(11) DPF manual regeneration switch

This switch is used to select DPF manual regeneration.

For details of the DPF manual regeneration procedure, see Section "3.18 Handling diesel particulate filter (DPF)" on page 177.

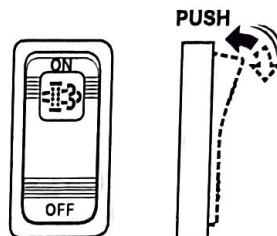

AS9B039

(12) Beacon lamp switch (Option)

With the starter switch in the ON position, use this switch to turn on or off the beacon lamp.

OFF: The beacon lamp goes off.

ON: The beacon lamp goes on.

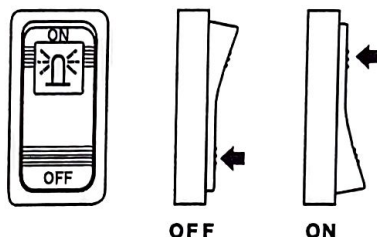

AS8B069

(13) Rear wiper switch (for cabin)

This switch can be used with the starter switch in the ON position.

- **PUSH:** Press the switch down to this position to spray washer fluid.
- **ON:** Set the switch to this position to operate the rear wiper.
- **OFF:** Set the switch to this position to stop the rear wiper.

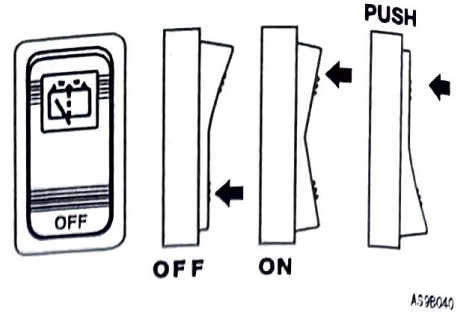

IMPORTANT

- Do not use the wiper switch when washer fluid will not spray. Doing so may cause pump failure.
- Wiping a dry window could damage the glass. Be sure to first spray water or washer fluid onto the glass and then operate the wiper.
- The wiper blade may freeze to the glass in cold weather. Do not attempt to operate the frozen wiper. Doing so may cause damage to the wiper motor.

2.3 Control levers

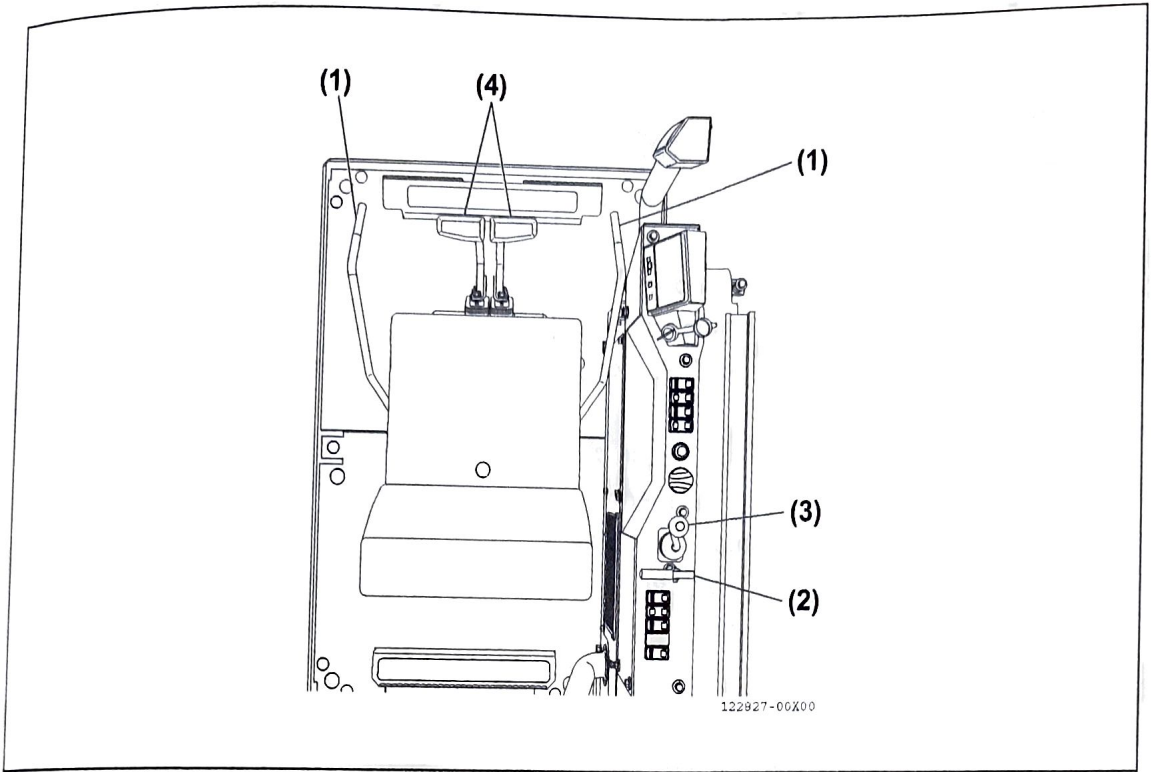

(1) Lock levers (for the travel operation)

The lock levers locks the travel operation. When the lock levers are pulled back, the parking brake is applied to lock the travel operation.

⚠ WARNING

- When leaving the operator's seat, be sure to lower the wagon fully and move all lock levers to the lock positions. Keep in mind that if you should touch an unlocked lever inadvertently, a serious accident could occur.
- Do not operate the lock levers while the machine is traveling. If the lock levers are pulled back during the machine travel, the parking brake will be applied, and the machine could make a hazardous sudden stop.
- Be sure to place the lock levers securely in the lock position. If not, they could slip out of the lock position. Thus always make sure that the lock levers are in the lock position as illustrated in the figure at the right.
- When operating the lock levers, be careful not to touch the travel levers.
- Remember that if the lock lever is not pulled back fully, the implement will not be locked.
- Note that even if the lock levers are in the lock position, the dump operation of the wagon is not locked.

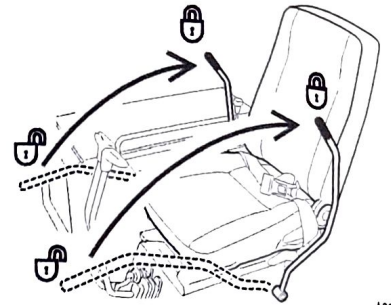

IMPORTANT

The machine uses the hydraulic lock system. If the lock lever is in the lock position, the travel motors will not operate although the travel levers are free to move. To reverse the operator's seat, also use the lock levers. Refer to Section "2.12 Operator's seat" on page 122.

(2) Dump lock lever**⚠ WARNING**

Be sure to set the dump lock lever to the lock position before inspecting, servicing or storing the machine.

Use this lever to lock the dump lever. When dump lock lever is pushed down, the dump lever is locked.

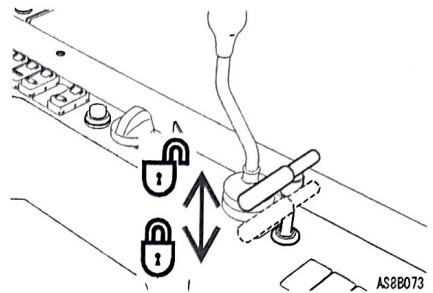
**(3) Dump lever****⚠ WARNING**

- Be aware that the machine body may be raised suddenly and tip over due to its momentum when dumping the wagon on a slope.
- It is dangerous to run the machine with the wagon in the dump position, because the machine will be unstable.
- When traveling with the machine, keep the wagon parallel to the crawlers. If the machine travels with the wagon swung to the right or the left, the machine will be unstable. (For the swing wagon type.)
- Make sure there are no persons near the machine before dumping the wagon.

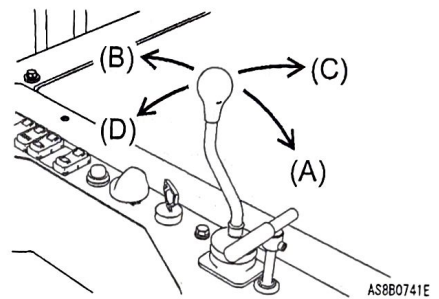

Use this lever to dump and lower the wagon. For the swing wagon type, the dump lever is also used for the swing operation of the wagon.

(A) Dump: The wagon is raised.

(B) Lower: The wagon is lowered.

For the swing wagon type

(C) Left swing: The wagon rear is turned to the right.

(D) Right swing: The wagon rear is turned to the left.

Neutral position: The wagon is stopped and kept in the position.

(4) Travel levers

⚠ WARNING

- Never turn the machine on a slope or run it across the slope. Move down to flat ground and then make a turn to travel safely.
- Run the machine longitudinally on a slope. Never run the machine diagonally on a slope or across a slope to prevent it from overturning or skidding.
- Be sure to turn at low speed. Making a turn at high speed or a spin-turn may cause a load shift or falling load.
- Do not return the travel levers to neutral position quickly while the machine is traveling at high speed.
- Return the travel levers to neutral position slowly.

IMPORTANT

Note that the center of turn of the machine varies depending on whether the wagon is in loaded or unloaded state.

The travel levers control the traveling of the machine.

(A) Forward: Push the travel levers forward together.

(B) Reverse: Pull the travel levers backward together.

Neutral position: The machine stops.

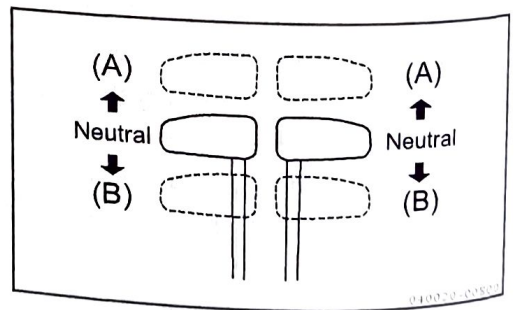

2.4 Engine hood

⚠ WARNING

- Do not open the engine hood while the engine is running. Check and service the engine after it has been stopped and temperatures have cooled.
- Be extremely careful in windy weather as the engine hood may be closed by a strong wind.

■ Opening the engine hood

1. Insert the starter switch key into the cylinder lock (1) and turn it clockwise to unlock the engine hood.
2. Raise the engine hood.
3. Set the stay (2) up and insert it into the stay hole in the engine hood to hold it in place.



■ Closing the engine hood

1. Remove the stay (2) from the stay hole while supporting the engine hood with a hand and put it back in the holder.
2. Lower the engine hood slowly and press it down until it clicks into place so that the engine hood is locked.

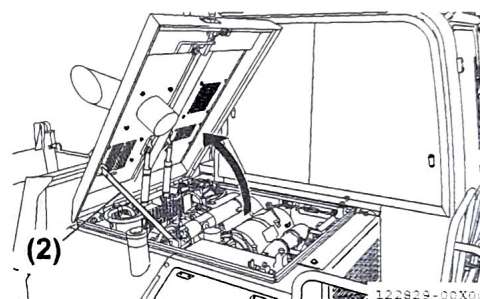

Note:

Make sure that the engine hood is completely closed and locked to prevent it from rattling.

2.5 Side cover

The air cleaner, pre-filter, fuel filter, tools and grease gun are located under the side cover.

■ Opening of the side cover

1. Insert the starter switch key into the cylinder lock and turn it counterclockwise to unlock the side cover.
2. Set the stay up and insert it into the stay hole in the side cover to hold it in place.

■ Closing of the side cover

1. Support the side cover with a hand to remove the stay from the stay hole.
2. Place the stay back in place.
3. Lower the side cover slowly and close it.
4. Insert the starter switch key into the cylinder lock and turn it clockwise to lock the side cover.

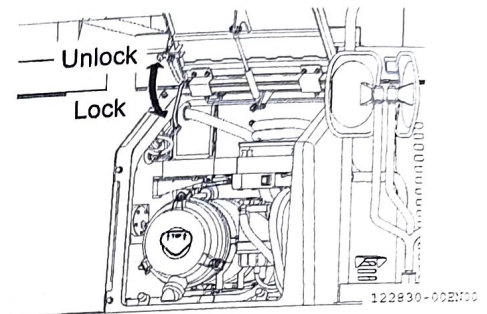
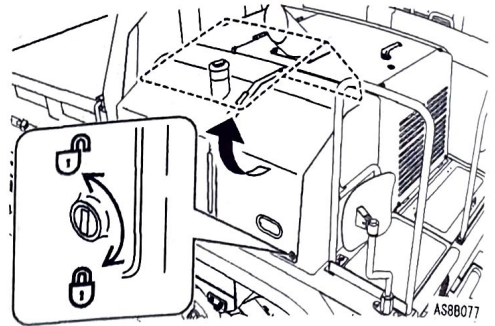

2.6 Battery cover

The battery is stored in the battery cover.

■ Opening of the battery cover

1. Insert the starter switch key and turn it counterclockwise to unlock the battery cover.
2. Fully open the cover, and the cover is locked.

■ Closing of the battery cover

1. Hold the battery cover by hand and disengage the stay to release the lock.
2. Close the battery cover softly.
3. Insert the starter switch key and turn it clockwise to lock the battery cover.

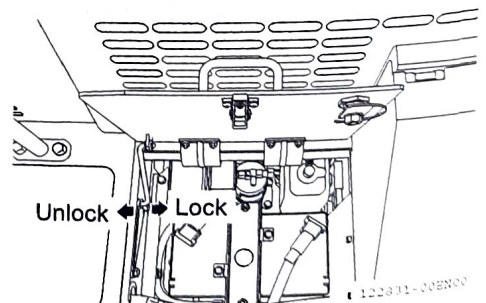
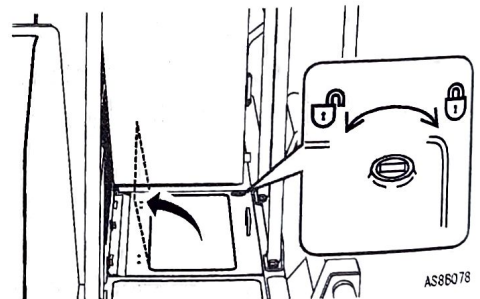

2.7 Urea tank cover

The urea tank is located under the urea tank cover.

■ Opening of the urea tank cover

1. Insert the starter switch key into the cylinder lock and turn it counterclockwise to unlock the urea tank cover.
2. Set the stay up and insert it into the stay hole in the urea tank cover to hold it in place.

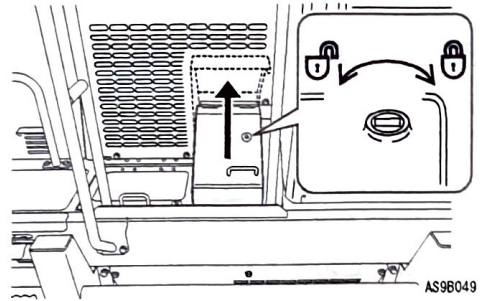

■ Closing of the urea tank cover

1. Support the urea tank cover with a hand and remove the stay from the stay hole.
2. Lower the urea tank cover slowly and close it.
3. Insert the starter switch key into the cylinder lock and turn it clockwise to lock the urea tank cover.

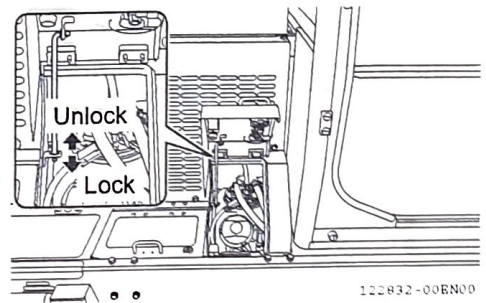

2.8 Cabin

Handling the cabin

⚠ WARNING

- To avoid bodily injury while operating the machine, make sure the side door and upper windshield are securely locked in either the open or shut position. If they are not securely locked, they may open or close unexpectedly.
- Never stick your hands or your head out of an open side door or windshield.

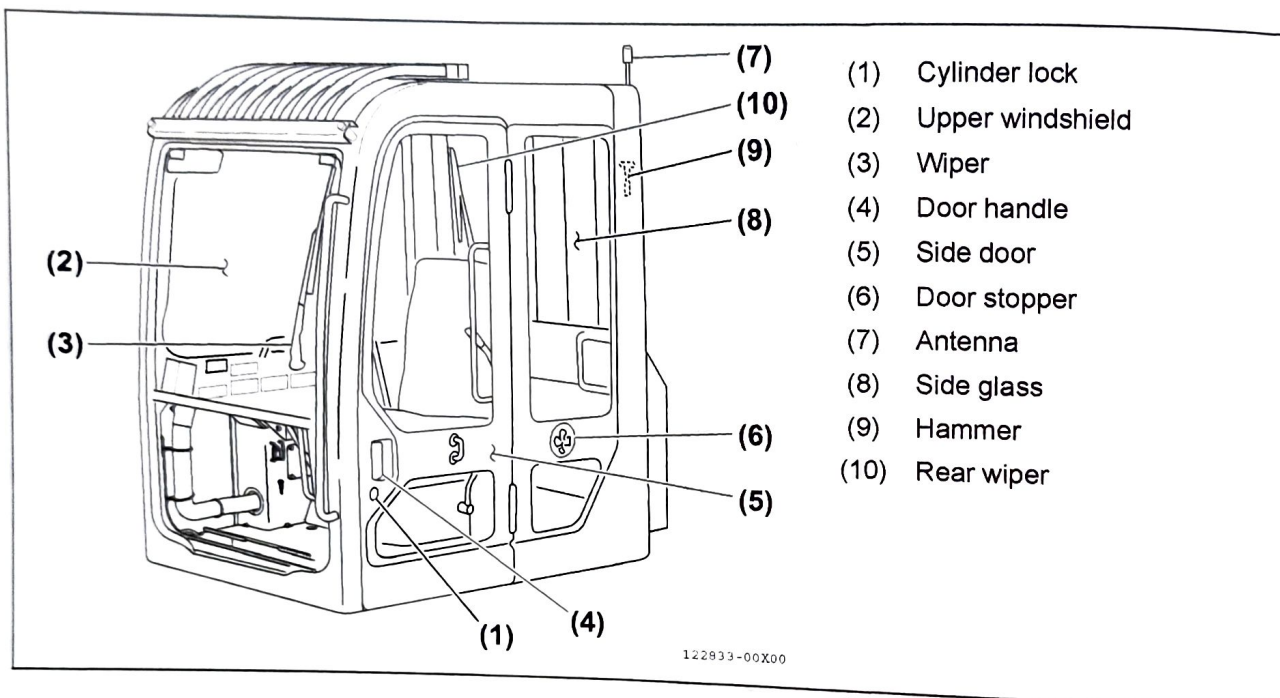

⚠ WARNING

Both the upper and lower windshields can be opened and closed. Securely lock the upper and lower windshield with the locks when storing or closing them.

Opening and closing the cabin side door

■ From outside

1. Insert the starter switch key into the cylinder lock (A).
2. Turn the key clockwise to unlock the side door.
3. Pull door handle (B) back to open the side door.
4. Fully open the side door and press it against the cabin until the latch clicks to lock the side door in the open position.
5. To close the side door locked in the open position, push release lever (C) down inside the cabin to unlock the side door.
6. After closing the side door, turn the starter switch key counterclockwise to lock the side door.

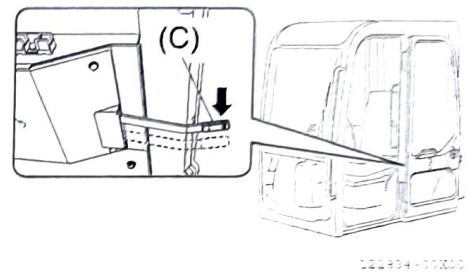
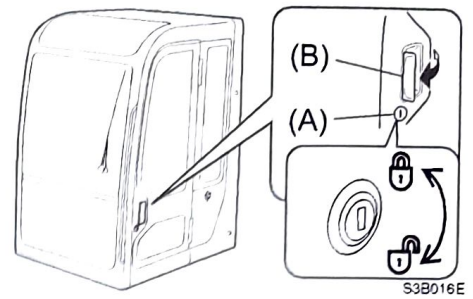

■ From inside

1. Push knob (D) down to open the side door.
2. To close the side door locked in the open position, push release lever (C) down to unlock the side door.
3. Grip the door handle and close the side door.

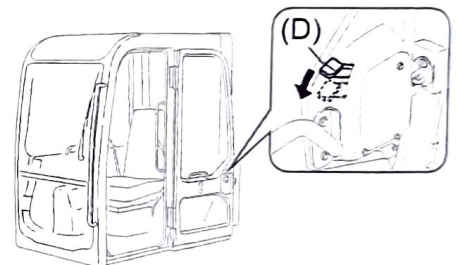

Opening and closing the upper windshield

⚠ WARNING

- To avoid bodily injury, securely grasp the handles with both hands when opening and closing the windshield.
- To avoid bodily injury while operating the machine, make sure the upper windshield is securely locked when it is in the open position. If it is not securely locked, it may close unexpectedly.
- Never stick your hands or your head out of an open windshield.

The upper windshield can be opened and closed from inside and housed under the ceiling. When opening and closing the upper windshield, follow the steps below.

■ Opening the upper windshield

1. To open the upper windshield (C), grasp the handles (A) on both sides of the upper windshield with your hands and press the knobs (B) down with your thumbs to unlock the locks.
2. Push the upper windshield (C) up while pulling it inward.
3. Release your thumbs from the knobs (B), push the upper windshield (C) all the way up, and then secure it with the stoppers (D).
4. To close the upper windshield (C), grasp the handles (A) on both sides of the upper windshield with your hands and press the knobs (B) down with your thumbs to unlock the locks.
5. Pull the upper windshield (C) down slowly while sliding it forward.
6. Release your thumbs from the knobs (B), push the upper windshield (C) forward, and then secure it with the stoppers (D).

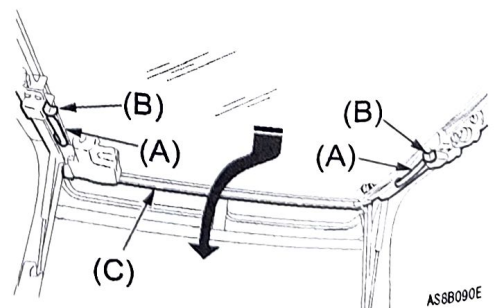
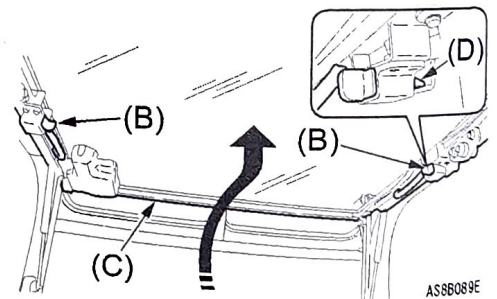
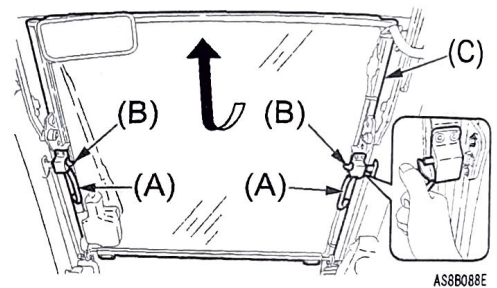

Opening and closing the lower windshield

⚠ CAUTION

Open and close the lower windshield only after the upper windshield is housed under the ceiling.

1. Open and slide up the upper windshield into the ceiling to hold it in place
2. Put lower windshield (D) between the fingers and pull it out slowly.
3. Hold the lower windshield firmly, put it on the supports (F) and secure it with guide (E).

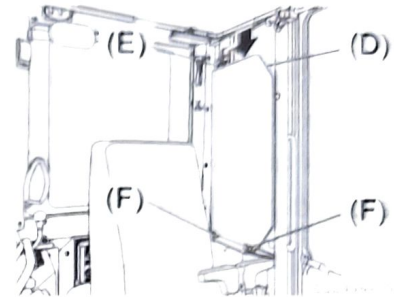
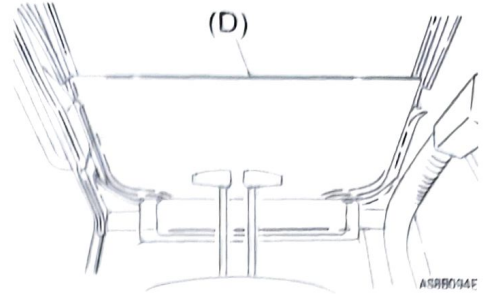

Opening and closing the right window glass

The windows on the right can be slid to the right and left directions.

1. Unlock the window by taking the stopper (G) with your fingers.
2. Slide the window to the rear side of the machine.

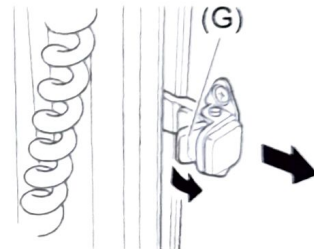

Emergency exit

If the door of the cabin should not open, open the right window to escape from the operator's cab.

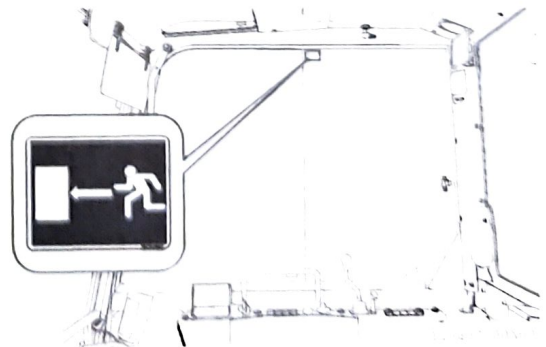

Hammer for emergency escape from operator's cab

If the door of the cabin should not open, hammer (A) is provided inside the cabin to escape from the operator's cab in an emergency.

Break the window glass with the hammer (A) to escape from the operator's cab.

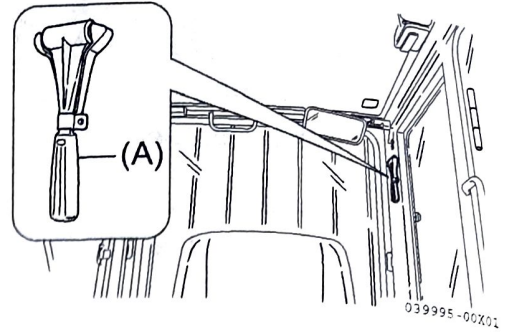

IMPORTANT

- Remove the broken pieces of the window glass from the window frame to prevent any injury by those broken pieces.
- Watch your step not to slip on the broken pieces of the window glass which dropped around your feet.

2.9 Fuse box

Fuse box

⚠ CAUTION

- When replacing a fuse, be sure to turn off the power by turning the starter switch key to the OFF position.
- Using the wrong fuse or shorting out a fuse holder could damage the gauges, the electrical equipment and the wiring due to overheating.
- If a new fuse blows out immediately after replacement, there may be a problem with the electrical system. Ask your dealer for assistance.

The fuses protect the electrical equipment and the wiring from a burnout.

If a fuse is corroded with white deposits or if a fuse is loose in the holder, it must be replaced with a new one.

Open the battery cover (1). Remove the fuse cover (2) and replace fuses.

If a fuse needs to be replaced, be sure to replace the fuse with one that has the same capacity as the original.

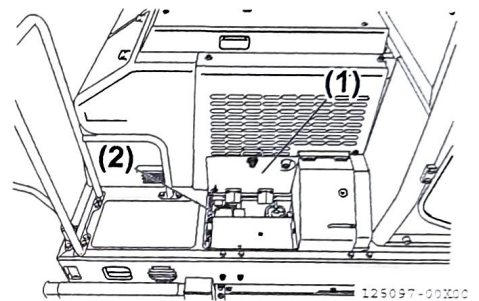

120 2. Description of Control Devices

Fuse capacity and circuit name

Fuses are arranged in the order shown in the tables below.

No.	Fuse capacity	Circuit name	Fuse No.
1	10A	Travel alarm	F4
2	15A	Lock levers	F3
3	20A	Cabin	F2
4	25A	Lights	F1
5	15A	Ignition (Start)	F8
6	10A	Horn	F7
7	5A	Switch lamps	F6
8	20A	Option	F5
9	15A	NOx sensor	F12
10	25A	SCR heater	F11
11	25A	SCR system	F10
12	25A	ECU	F9

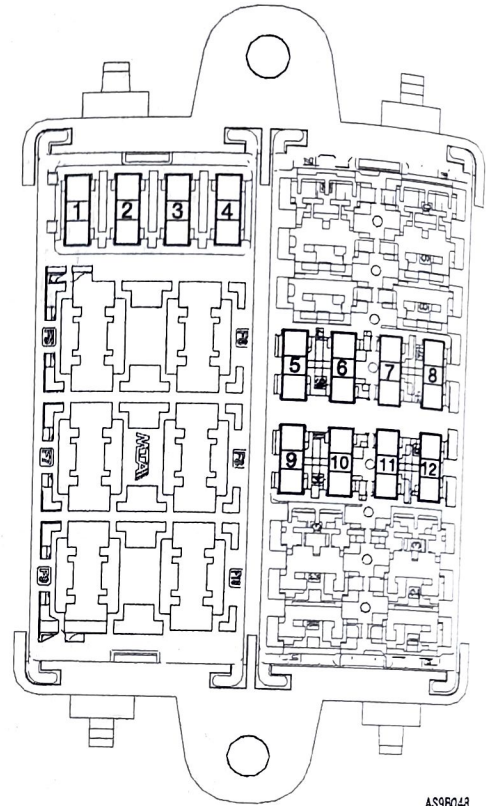

AS98043

2.10 Fuel supply port cap

The fuel supply port cap is equipped with a locking system.

Open and close it with the starter switch key.

Locking and unlocking the fuel supply port cap

■ Unlocking the fuel supply port cap

1. Open the fuel supply port cap cover and insert the starter switch key.
2. Turn the starter switch key clockwise to unlock the fuel supply port cap.
3. Turn the fuel supply port cap counterclockwise to remove it.

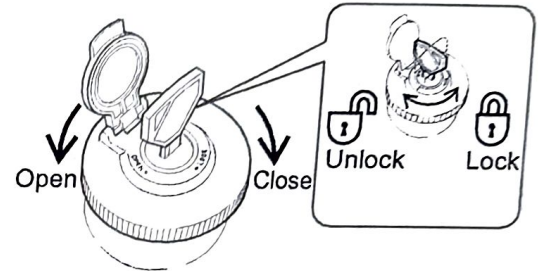

122891-00EN00

■ Locking the fuel supply port cap

1. Install the fuel supply port cap and turn it clockwise.
2. Turn the starter switch key counterclockwise to lock the fuel supply port cap.
3. Pull out the starter switch key, and close the fuel supply port cap cover.

2.11 Urea filler cap

■ Opening the urea filler cap

1. Turn urea filler cap (1) counterclockwise until it clicks.
2. Remove urea filler cap (1).

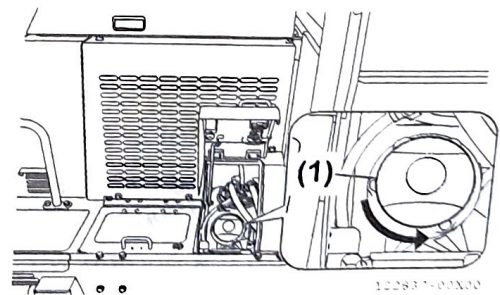

122837-00X00

■ Closing the urea filler cap

1. Put chain (2) back in place and place urea filler cap (1).
2. Turn urea filler cap (1) fully clockwise.

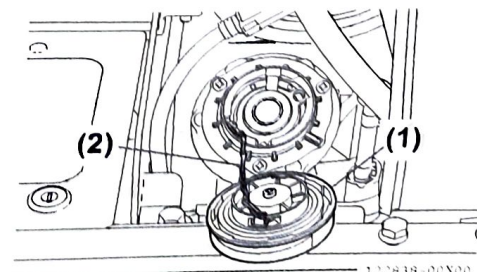

122838-00X00

2.12 Operator's seat

⚠ WARNING

- Be sure to adjust the seat slide to obtain the best operating position whenever a new operator begins work.
- Do not place any objects within the moving area of the operator's seat.
- Do not adjust the operator's seat while operating the machine.

Adjust the seat so that the operator can easily operate the control levers in good posture.

Seat position control

■ Fore/aft adjustment

1. Pull lever (A) upward to slide the seat forward and backward.
(Adjustable amount : 3.93 in. (100 mm) (11 positions))

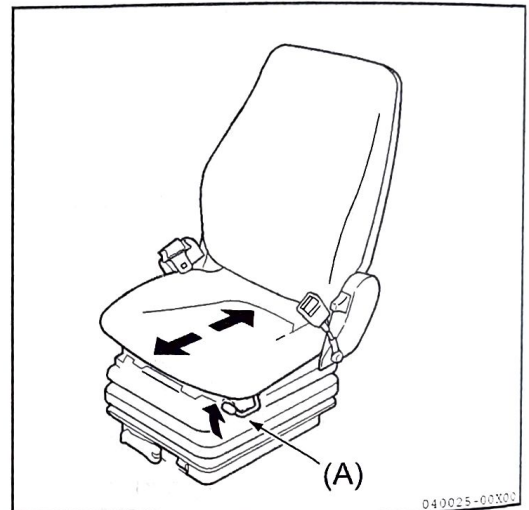

■ Reversing operator's seat

⚠ WARNING

Be sure to stop the engine when reversing the operator's seat, to avoid bodily injury.

1. Pull the lock levers (B) back from their lock position to unlock the operator's seat, and turn the seat 180 degrees. After reversing the seat, check that the seat is locked. When the seat is locked, the lock levers (B) automatically return to their lock position.

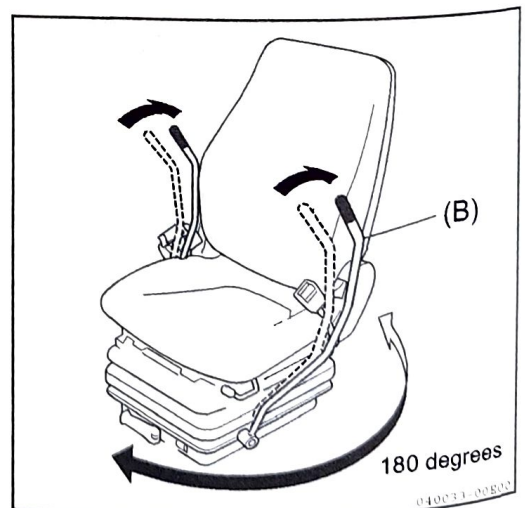

■ Backrest angle adjustment

1. Pull lever (C) upward to latch into the desired position.
(Adjustable amount : 90 degrees)

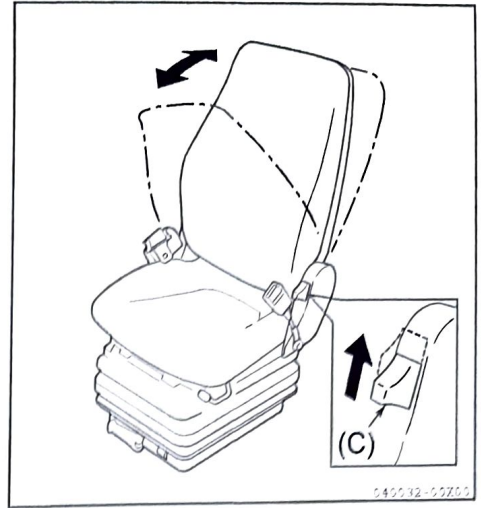

Suspension part control

■ Height adjustment

1. Raise the operator's seat to the required height until it audibly latches into place.
2. When the operator's seat is raised above the highest setting, it drops back down to the lowest position.
(Adjustable amount: 3 positions)
(Suspension stroke: 3.94 in. (100 mm))

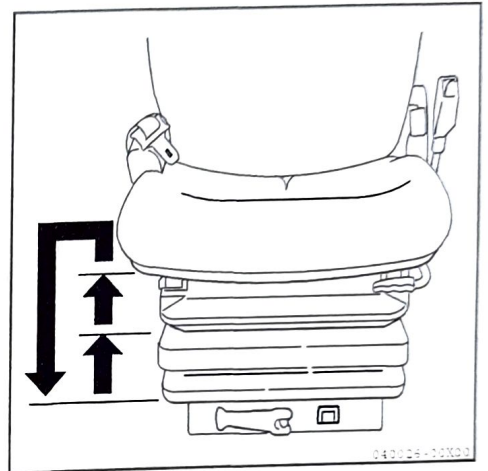

■ Weight adjustment

1. The seat can be adjusted for the operator's weight by turning the weight adjuster lever (D) with the seat empty.
The setting weight can be read at the indicator (E).
2. Turn the weight adjuster lever (D) clockwise, the setting weight is increased.
3. Turn the weight adjuster lever (D) counter-clockwise, the setting weight is decreased.
(Adjustable weight: 110 to 287 lbs. (50 to 130 kg))

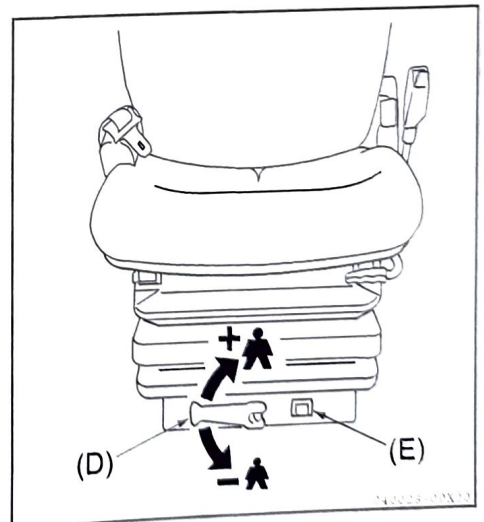

2.13 Grease gun holder

A grease gun holder is provided under the side cover on the right side of the machine. When the grease gun (option) is not used, replace it in the holder next to the tools.

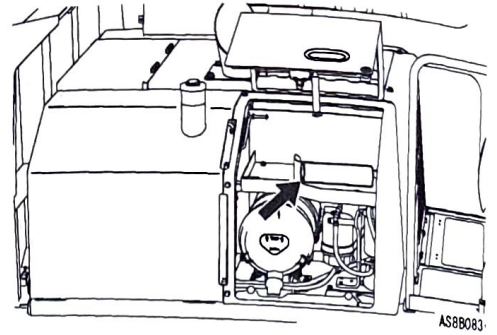

2.14 Storage pocket for the operation & maintenance manual

The storage pocket have been provided at the positions shown in the figure at the right. Keep the operation & maintenance manual in a nylon bag and store it in either of the storage pocket so that you can refer to it whenever you need.

Canopy

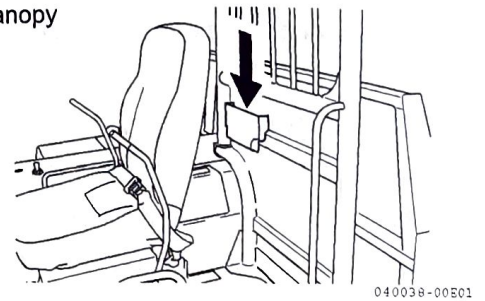

Cabin

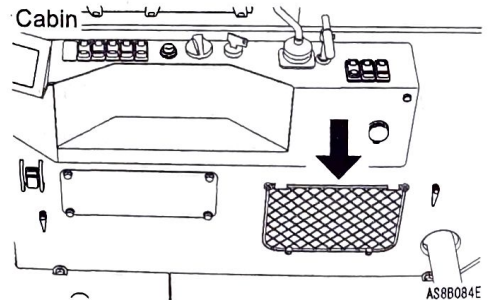

2.15 Tool storage space

A space for storing tools is provided as shown in the illustration.

Replace the tools after use.

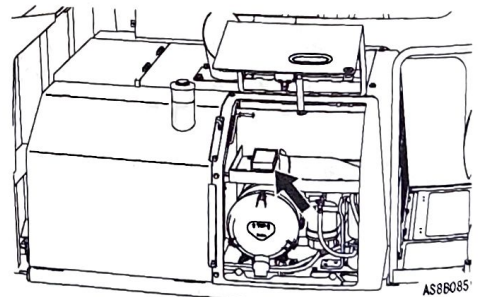

2.16 Wagon stopper

⚠ WARNING

Be sure to install the wagon stopper to hold the wagon when inspecting or servicing the machine with the wagon in the dump position.

The wagon stopper is the lock device to prevent a fall of the wagon. To install and remove the wagon stopper, follow the procedures below.

■ Installation of the wagon stopper

1. Start the engine and idle it.
2. Set the dump lever to the dump position, and dump the wagon fully.
3. Lock the dump lever and stop the engine.
4. Install the wagon stopper to the wagon.

■ Removal of the wagon stopper

1. Unlock the dump lever and slightly move it to the dump side to remove the wagon stopper.
2. Remove the wagon stopper.
3. Lower the wagon fully.
4. Store the wagon stopper in the specified position.

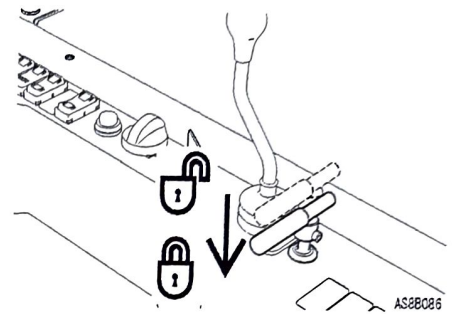

Three-side flaps wagon type



Scoop-end wagon type, swing wagon type

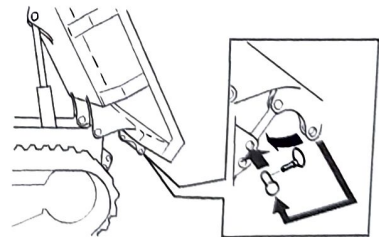

2.17 Handling air conditioner (Option for cabin)

Component parts of the air conditioner

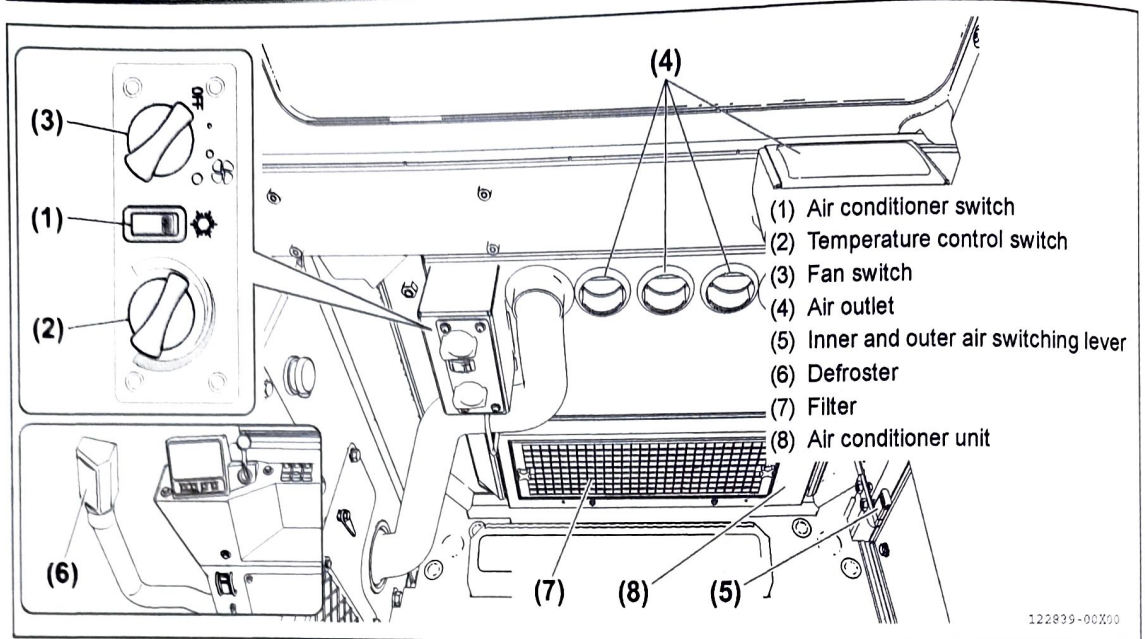

(1) Air conditioner switch

Use this switch to turn ON the air conditioner when the engine is running and the fan switch is ON. To stop the air conditioner, press the switch again or turn OFF the fan switch.

O...OFF
 I...ON

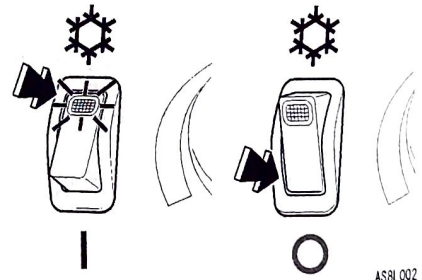

(2) Temperature control switch

This switch is used to control the temperature of the air blown by the air conditioner.

Turn it counterclockwise to lower the air temperature

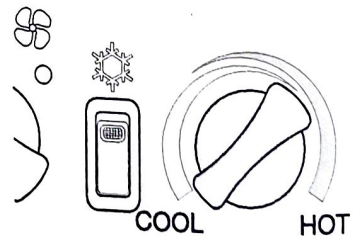

(3) Fan switch

This switch is used to control the air volume.

OFF : Stop (the switch serves also as the main switch.)

- o : Low
- o : Medium
- o : High.

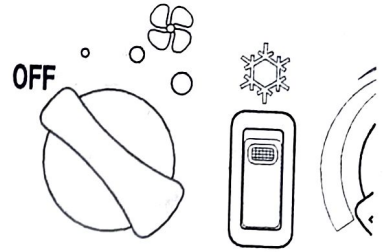

AS8L004

(4) Air outlet

The grille knob (1) of the air outlet is used to adjust the air direction.

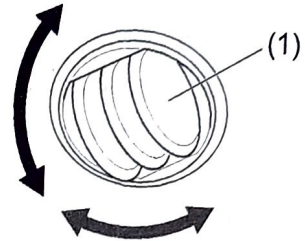

032069-00X01

(5) Inner and outer air switching lever

This lever is used to switch between outer air induction and inner air circulation.

Outer air induction:

Use this position to induce the fresh air from outside or to defrost the windshield.

Inner air circulation:

Use this position to cool or heat the cabin in a short time or when the outside air is dirty.

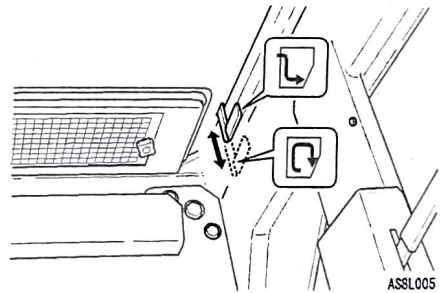

AS8L005

(6) Defroster

It is used to defrost the windshield.

Use the louver to adjust the direction of air coming out of the air outlet.

(7) Filter

See "Checking and cleaning the filter" on page 134.

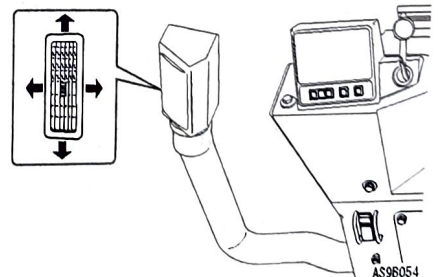

AS9B054

How to use the air conditioner

⚠ CAUTION

- The eyes might get sore from smoking when the cabin is air conditioned. Ventilate the cabin by opening the window slightly when smoking.
- Exposing your eyes or hands to the refrigerant could result in blindness or frostbite. Never attempt to touch the refrigerant or loosen any parts of the cooling circuit. In the event of refrigerant leakage, keep away fire.
- Leaving the windshield stained or fogged could be dangerous because of poor visibility. For good visibility, always keep clean the windshield using the defroster and other means.
- Some mist might blow off with cooled air when the cabin is air conditioned. This occurs because the water particles in the wet air are frozen and blown out. So, it is not abnormal.
- When using the air conditioner after parking the cabin in the hot weather, ventilate the cabin by opening the door and windows to let the hot air inside go out of the cabin so that the air-conditioning can work efficiently.
- Take care to adjust the temperature properly not to cool the air inside the cabin too long because it is not good for the operator's health.
- If the air does not blow off, the air volume is small or the cabin is not air conditioned well when the air conditioner is turned ON, turn the air conditioner switch OFF and ask your dealer to check the air conditioner. If you keep using the air conditioner in the abnormal state, it will cause damage to the fan motor or the compressor.
- Even in the seasons when the air conditioner is not used, operate the air conditioner for a few minutes once or twice every two or three weeks. That prevents the rotating parts such as the compressor from running out of oil, which prevents malfunction of the parts in turn.

■ How to use the air conditioner

1. Press the air conditioner switch and turn the temperature control switch fully counterclockwise.
2. Turn the fan switch fully clockwise to set it to the HI position.
3. Adjust the temperature inside the cabin properly with the temperature control lever and the fan switch after the cabin is cooled off.

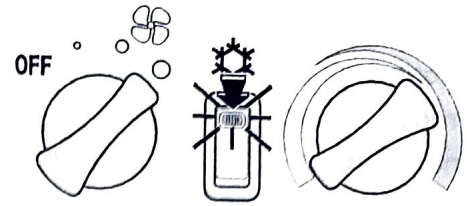

ASBL007

IMPORTANT

Be sure to turn the air conditioner ON after starting the engine to prevent excessive force to the compressor etc.

3. Operating Instructions

3.1 Checking before starting the engine

Walking check (visual inspection) around the machine

Before starting the engine, visually check the outside and underside of the machine as follows: Check bolts and nuts for loose connections; check the fuel, oil, and water for leaks; and also check the wagon and the hydraulic system to see that they are operating properly. In addition, check the electrical wiring for loose connections and for dust deposits in the heat build-up areas.

⚠ WARNING

Accumulation of combustibile materials, or fuel or oil leakage around the engine itself, high-temperature engine parts such as the DPF and SCR, or the battery may cause fire in the machine. Perform adequate inspections and contact your dealer without fail if any abnormalities are discovered.

Check the following points before initial start-up for the day.

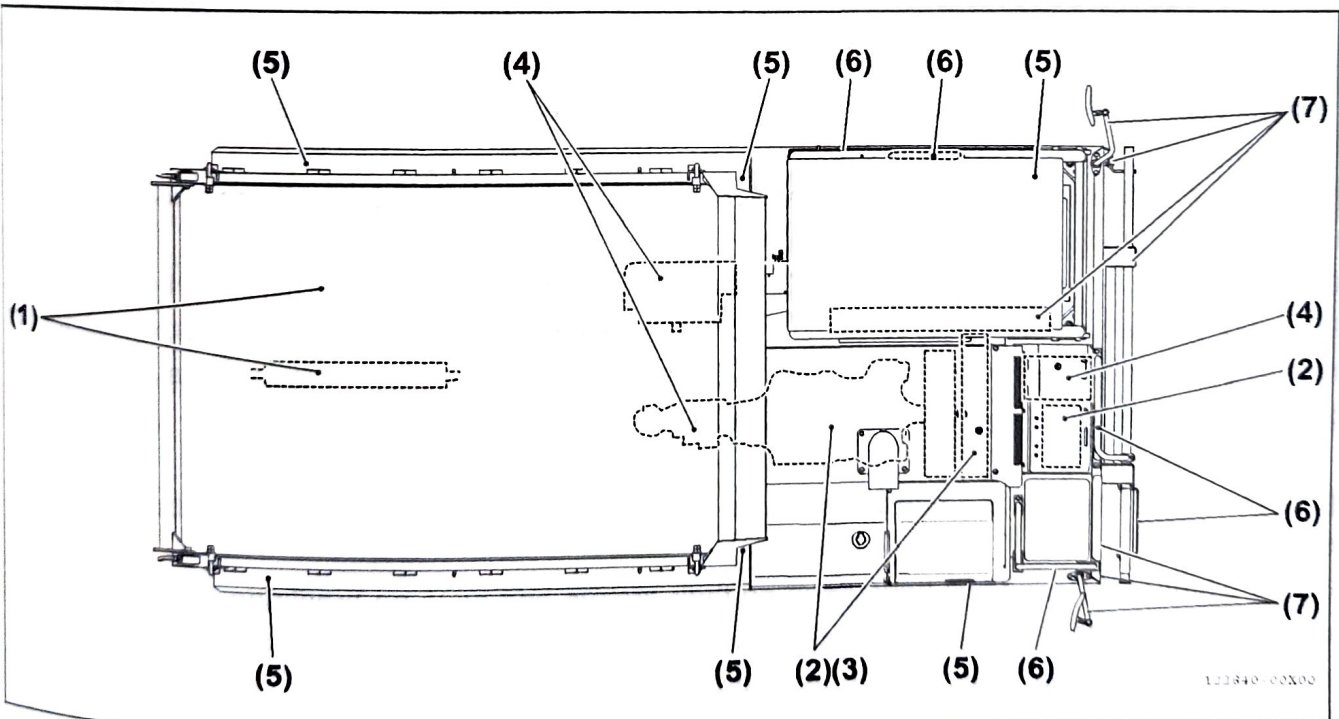

(1) Checking the wagon, hydraulic cylinder, pins, and hoses for damage, wear and loose connections

Check the wagon, hydraulic cylinder, pins, and hoses for damage, excessive wear and loose connections. If any abnormality is found, take corrective action.

(2) Removing dust accumulated around the engine, battery and radiator

Check whether dust has accumulated around the engine or the radiator and whether combustible materials have accumulated around high-temperature engine parts such as the DPF and SCR or the battery. Remove any dust or other combustible materials.

(3) Checking the engine and its accessories for oil or water leakage

Check the engine for oil leakage and the cooling system for water leakage.

If oil or water leakage is found, take corrective action.

(4) Checking the hydraulic system, hydraulic oil tank, hoses, and joints for oil leakage

Check for oil leakage. If oil leakage is found, take corrective action.

(5) Checking the undercarriage (crawlers, sprockets, rollers, and idlers) for breakage, wear, loose bolts, and oil leakage around the rollers

If any breakage or wear is found, correct it. Retighten the bolts if necessary.

If oil leakage is found, take corrective action.

(6) Checking the handrails and safety guards for breakage and loose bolts

If any breakage is found, take corrective action. Retighten the bolts if necessary.

(7) Checking the gauges, monitor, switches, flashers, headlights, and rearview mirror for breakage and loose bolts

Check the gauges, monitor, switches, flashers, headlights, and rearview mirror for breakage and loose bolts. If any abnormality is found, replace the gauge, monitor, switch, flasher, headlight, or rearview mirror with a new one, or retighten the bolts if necessary. Clean the surface of the gauges, monitor, switches, flashers, headlights, and rearview mirror.

(8) Checking whether the windows have been on their groove and have no breakage (for cabin)

Check whether the windows have been on their groove and have no breakage. If any breakage is found, replace the window with a new one. If the window gets off the groove or broken during operation, stop the operation and repair the window immediately.

Checking before start-up

Check the following points before initial start-up for the day.

■ Checking and replenishing the coolant

⚠ WARNING

- Do not remove the fill cap from the radiator unless supplying the coolant.
- Check the coolant level in the sub-tank when the engine is cool.

1. Open the battery cover and check whether the coolant level in the sub-tank (1) (illustrated in the figure at the right) is between the H (FULL) and L (LOW) marks. If the coolant level is below the L mark, refill the sub-tank up to the H mark through the water supply port of the sub-tank (1).

For the coolant to be used, refer to Section "4. Fueling, Oiling and Greasing Based on Temperature Range" on page 233.

2. After replenishing, securely tighten the cap (2).

3. If the sub-tank is empty, check it for water leakage, and then, check the water level in the radiator (3).

If the water level is low, refill the radiator (3) first, then refill the sub-tank (1).

4. If the coolant level is proper, close the engine hood.

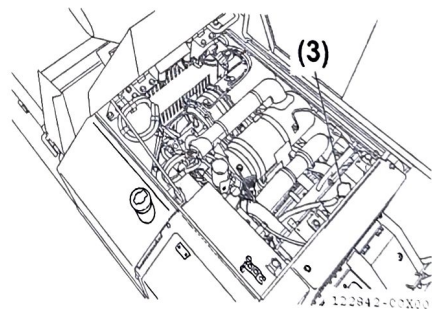
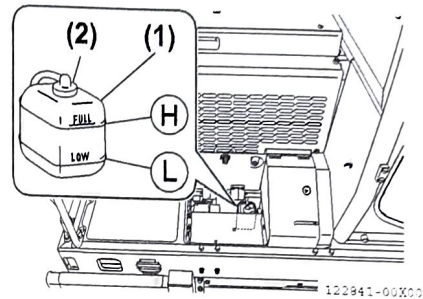

■ Checking and replenishing the engine oil

⚠ WARNING

- At operating temperature, the oil and dipstick areas are hot. Do not allow hot oil or hot components to contact the skin, to prevent bodily injury.
- Check the oil level and replenish oil after the engine has cooled down sufficiently.

1. Open the engine hood and securely hold it in that position with stay.
2. Pick up the dipstick (1) and wipe it with a rag to remove oil deposits.
3. Fully insert the dipstick (1) into the dipstick tube, then draw it out.

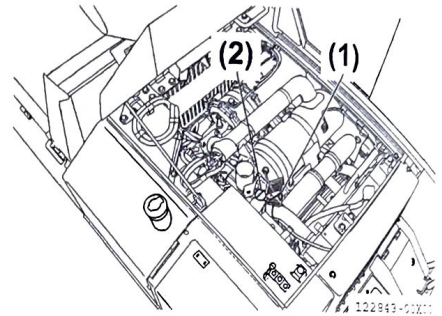

4. If the oil level is between the H (upper limit) and L (lower limit) marks, the engine oil level is appropriate. If the oil level is below the L mark, add engine oil through the oil supply port (2). For the quality of the engine oil to be used, refer to Section "4. Fueling, Oiling and Greasing Based on Temperature Range" on page 233.

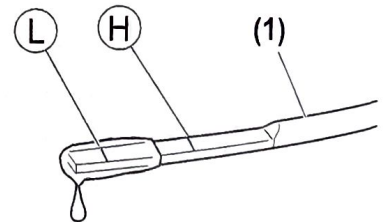

5. If the engine oil level is above the H mark, drain the excessive amount of oil through the drain plug (3), then recheck the engine oil level.

Refer to Section "Checking and replenishing the engine oil" on page 138.

6. After verifying that the amount of engine oil is appropriate, securely retighten the oil supply port cap and close the engine hood.

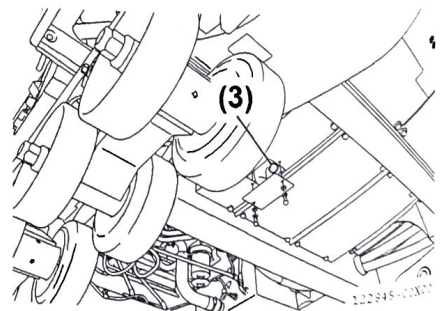

Note:

When checking the engine oil level after starting up the engine, stop the engine and allow more than 10 minutes for the engine to cool down.

If the machine is slanted, reposition the machine to ensure it is level before checking the engine oil level. Keep in mind that the excess engine oil must not be disposed of on the ground or the road.

■ Checking and replenishing the fuel in the fuel tank

⚠ WARNING

Be careful not to overfill the fuel tank because it could cause a fire. If the tank is overfilled, completely wipe off the spilled fuel.

⚠ WARNING

- Do not remove the strainer from the fuel supply port of the fuel tank when supplying fuel.
- Be careful not to allow any water that may be in the fuel container or dirt on the refueling equipment to enter the fuel tank.

IMPORTANT

Do not put fuel into the urea tank. Doing so may cause malfunctions.

1. Check the fuel level with the fuel meter (1). If the fuel level is low, add necessary fuel.
2. Remove the fuel supply port cap (4), and supply fuel to the fuel supply port, checking the fuel level with the fuel level gauge (3).

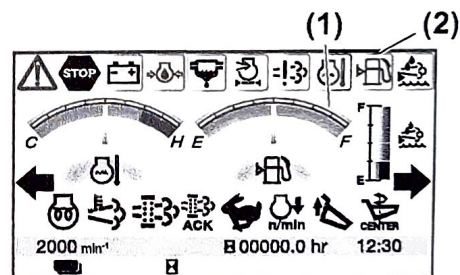

122846-00X00

If the fuel level warning lamp (2) comes on, it indicates that the amount of fuel left in the tank is approximately 5.5 Gals. (20.9 L).

Effective capacity of the fuel tank: 32.0 Gals. (121.1 L)

For the quality of the fuel to be used, refer to Section "4. Fueling, Oiling and Greasing Based on Temperature Range" on page 233.

3. After refueling, securely retighten the fuel supply port cap (4).

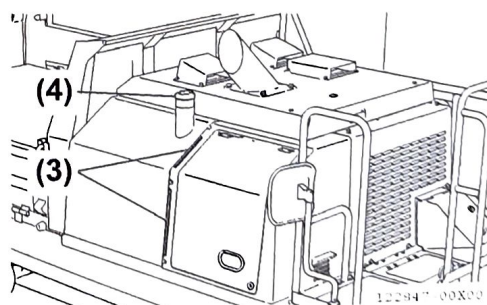

122847-00X00

Operating and checking instructions before starting up the engine

⚠ WARNING

- Accidentally setting the lock levers to the unlock position can cause the machine to move suddenly, possibly causing a serious accident.
- When leaving the operator's seat, be sure to place the lock levers securely in the lock position.

1. Confirm that the "SERVICING IN PROGRESS" tag is not attached.
2. Check that the travel levers are in neutral, that the lock levers (1) are in the lock position, and that the dump lever (2) is locked.
3. Fasten the seatbelt (13) snugly.
4. Insert the starter switch key into the starter switch (3) and set it to the "ON" position.
5. Then check the following points:

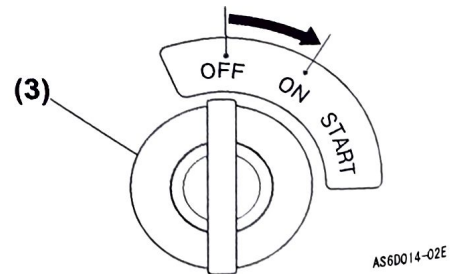
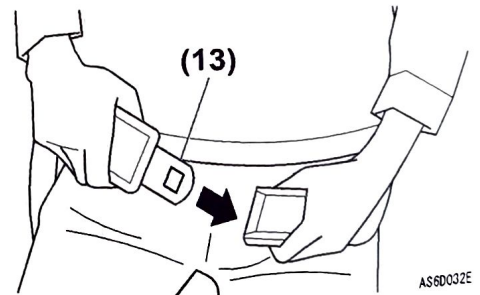
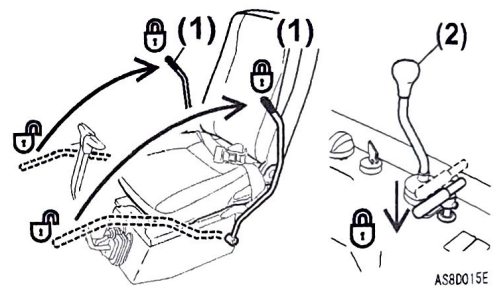
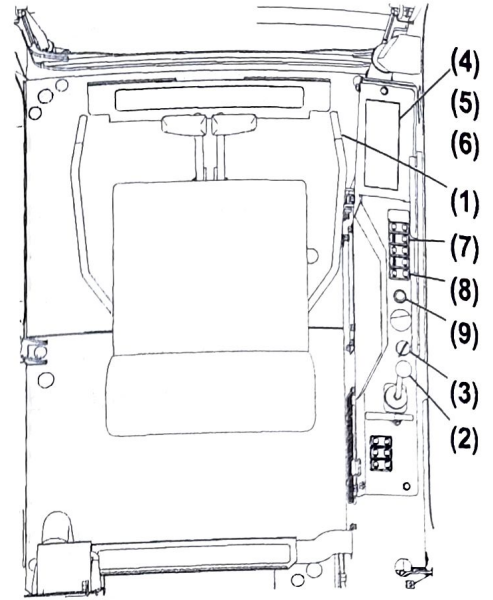

1. The symbols for engine oil pressure alarm lamp (4) and battery charge alarm lamp (5) on the LCD monitor will continue flashing until the engine has started.

The duration of glow lamp (6) illumination varies depending on the coolant temperature.

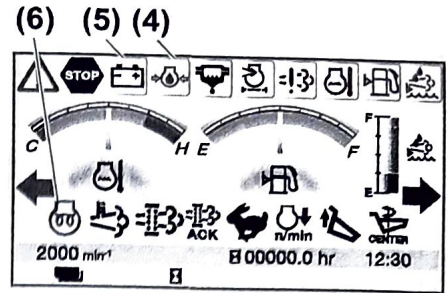

122953-00X00

2. Press the ON side of light switch (7) to check whether the headlights will illuminate.

If either or both of them do not illuminate, the lamp(s) might have blown out or the wire(s) connected to the lamp(s) might be broken or disconnected. Contact your dealer for service.

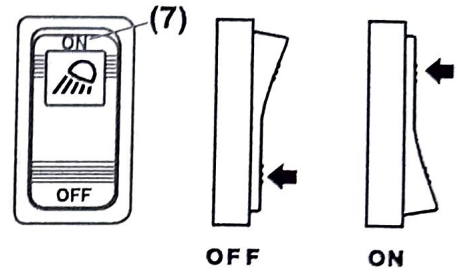

A32D016E

3. Operate turn signal switch (8) to check whether the turn signals will flash.

If either or both of them do not flash, the lamp(s) might have blown out or the wire(s) connected to the lamp(s) might be broken or disconnected. Contact your dealer for service.

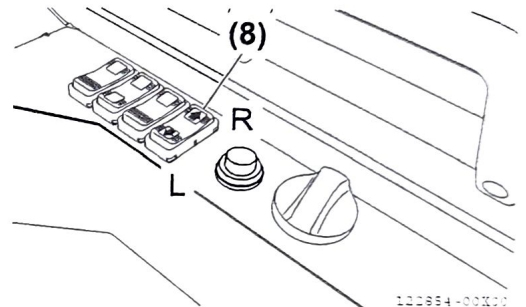

122954-00X00

4. Press horn switch (9) to check whether the horn will sound.

If the horn does not sound, the horn might be defective or the wire connected to the horn might be broken or disconnected. Contact your dealer for service.

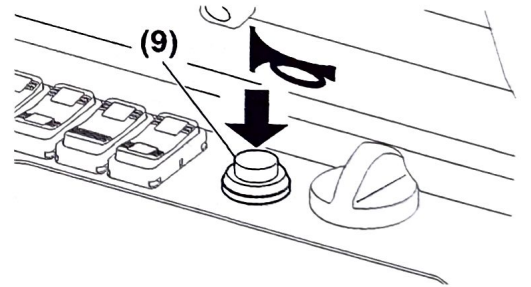

122955-00X00

3.2 Starting up the engine

Normal start-up

⚠ WARNING

- First check that there are no people or obstacles around the machine. Then sound the horn and start the engine.
- Be sure that you are seated on the operator's seat when starting the engine.
- When starting the engine in an enclosed place, be sure that there is adequate ventilation so that the exhaust gases can escape.

1. Set starter switch (1) to the START position to start the engine.
2. Release the starter switch key after the engine starts. The key will automatically turn back to the ON position.

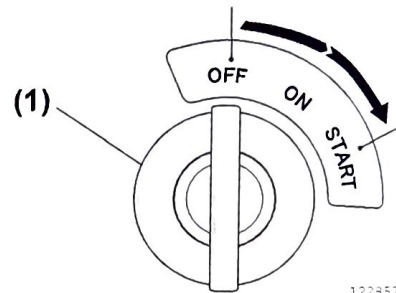
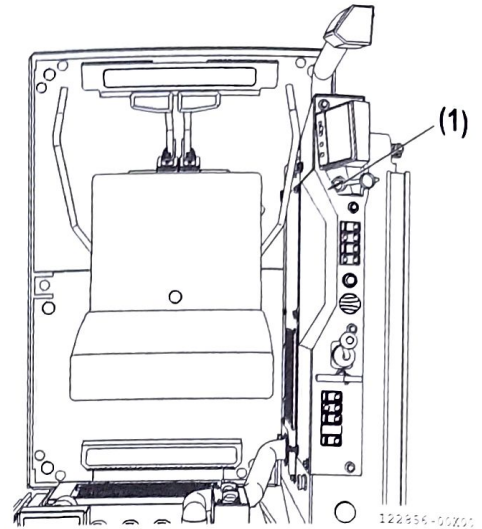

IMPORTANT

To protect the starter motor and the battery:

- Do not keep the starter switch key in the "START" position for more than 15 seconds.
- If the engine fails to start, do not attempt to start the engine immediately again, but set the switch to the "OFF" position and wait for approximately 30 seconds, then start the engine again.

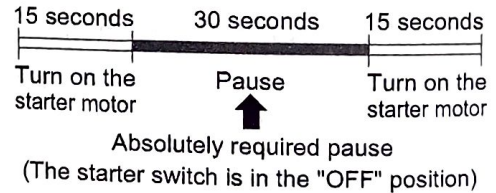

Starting the engine in cold weather

⚠ WARNING

- First check that there are no people or obstacles around the machine.
- Then sound the horn and start the engine.
- Be sure that you are seated on the operator's seat when starting the engine.
- When starting the engine in an enclosed place, be sure that there is adequate ventilation so that the exhaust gases can escape.

1. With starter switch (1) in the ON position, check whether the glow lamp is illuminated. If the lamp is illuminated, wait until it goes out.

Note:

The preheat time during which the lamp stays illuminated varies depending on the coolant temperature.

2. After the glow lamp goes out, turn the starter switch key to the START position to start the engine.
3. Release the starter switch key after the engine starts. The key will automatically turn back to the ON position.

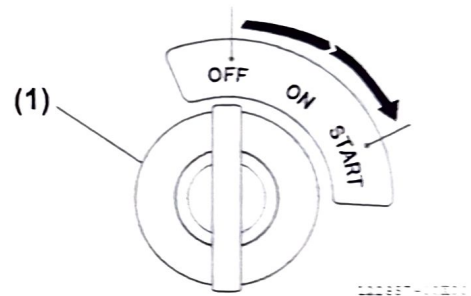
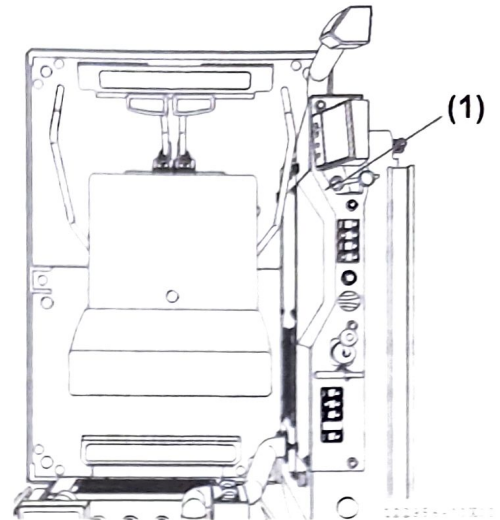

IMPORTANT

To protect the starter motor and the battery:

- Do not hold the starter switch key in the START position for more than 15 seconds.
- If the engine fails to start, do not attempt to start the engine immediately again. Set the starter switch back to the OFF position and wait for approximately 30 seconds. Then, repeat the steps below to start the engine.
- Running or operating the machine without an adequate warm-up in cold weather may adversely affect the machine performance; for example, low machine operation speed or inability of the machine to travel straight.
- When the machine is started at low temperatures, if the coolant temperature when engine startup has been completed is -15°C (5°F) or lower, the high idle speed will be limited to 1500 RPM for 10 seconds after engine startup has been completed to prevent turbocharger seizure. This limit will be cancelled by operating the accelerator to reduce the engine speed to less than 1500 RPM more than 10 seconds after engine startup.

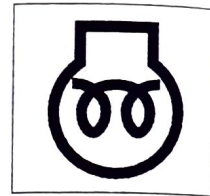

AS8B016

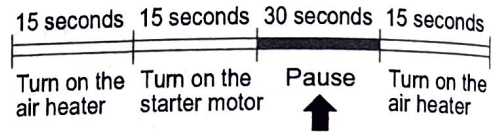

"Absolutely required pause"

040106-00E01

3.3 Operating and checking instructions after starting the engine

⚠ WARNING

- **Emergency stop.**

If abnormal operation occurs, turn the starter switch key to the "OFF" position, to shut off the electrical system and the engine. Then ask your dealer to check the machine.

- Always let the engine warm up before operation. Failure to do so may cause unexpected machine malfunctions.

IMPORTANT

- The proper hydraulic oil temperature is between 122°F and 176°F (50°C and 80°C). If you have to operate the machine at a low hydraulic oil temperature, increase the hydraulic oil temperature to about 68°F (20°C) before operating the implement.
- In the event that you have to operate any control lever at a temperature lower than 68°F (20°C), operate it gently.
- Do not accelerate the engine rapidly until the engine warms up.
- Do not keep idling at low or high speed for more than 20 minutes.

When idling the engine is necessary, sometimes apply load or idle the engine at medium speed.

After starting the engine, do not start operating the machine immediately but follow this procedure:

1. With lock levers (1) in the lock position, run the engine with no load for approximately 5 minutes.

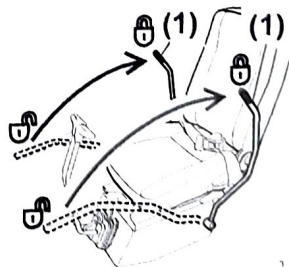

122858-00X00

2. After warm-up, check that symbols (2) on the LCD monitor are not illuminated.

However, the following symbols will remain illuminated in the following situations:

- (3): The wagon is in the dump position.
- (4): The travel speed change switch is in the high speed position.
- (5): The turn signal switch is on.
- (6): The wagon is parallel with the crawlers.
- (7): The lock levers are in the lock position.

3. Check the exhaust smoke color, machine noise and vibration level. If any abnormality is found, take corrective actions.

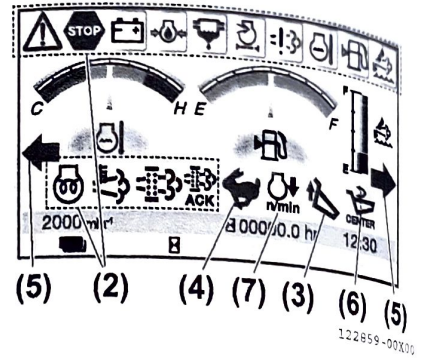

122859-00X00

3.4 Traveling

Traveling forward

⚠ WARNING

- A signal person should be in attendance to give signals at sites which are dangerous or not clearly in view of the operator.
- Set the operator's seat to the desired direction and securely lock it.
- Sound the horn before beginning travel, to alert the people near the machine.
- Clear all people from the working area.
- Clear obstacles from the path of the machine.
- Do not operate the travel levers rapidly while the engine is running at high speed. Otherwise, the machine may move unexpectedly, causing a serious accident.

1. Push the lock levers (2) down to unlock the travel operation.

2. Turn the accelerator dial (1) fully clockwise, and increase the engine speed.

3. Slowly push the travel levers (3) forward to move the machine forward.

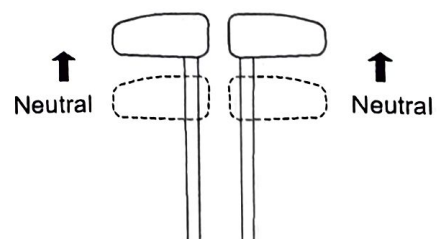
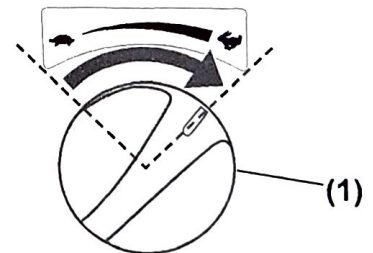
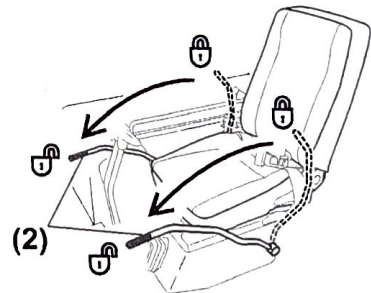
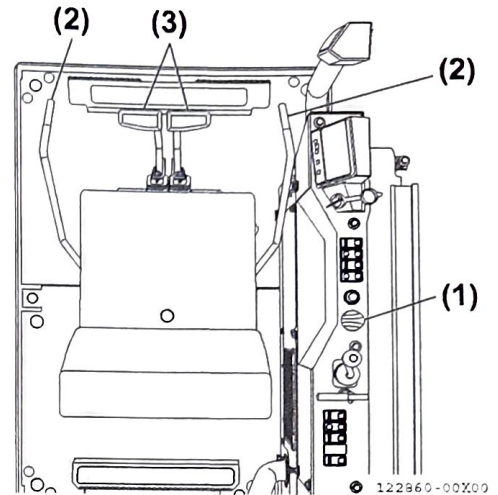

040042-00E01

Traveling in reverse

⚠ WARNING

- A signal person should be in attendance to give signals at sites which are dangerous or not clearly in view of the operator.
- Set the operator's seat to the desired direction and securely lock it.
- Sound the horn before beginning travel to alert the people near the machine.
- Clear all people from the working area.
- Clear obstacles from the path of the machine.
- There is a blind spot behind the machine. Make sure that no people are in the blind spot before traveling backwards.
- Do not operate the travel levers rapidly while the engine is running at high speed. Otherwise, the machine may move unexpectedly, causing a serious accident.

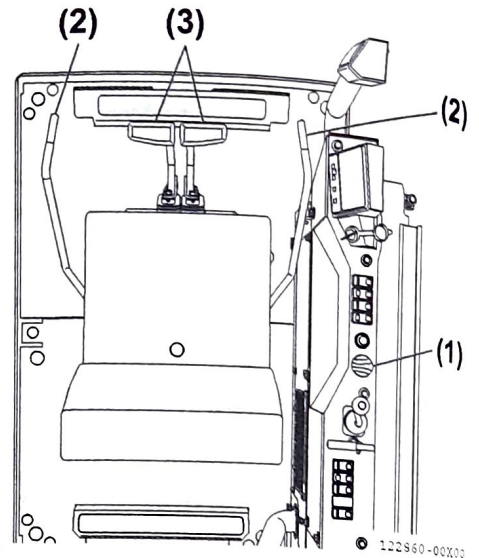

1. Push the lock levers (2) down to unlock the travel operation.

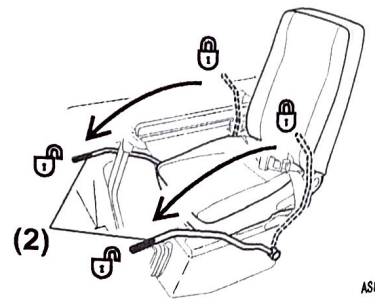

2. Turn the accelerator dial (1) fully clockwise, and increase the engine speed.

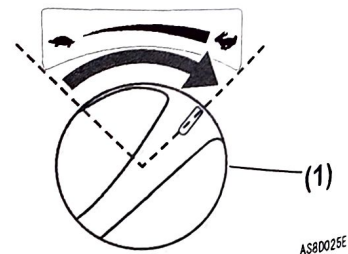

3. Slowly pull the travel levers (3) back to move the machine backwards.

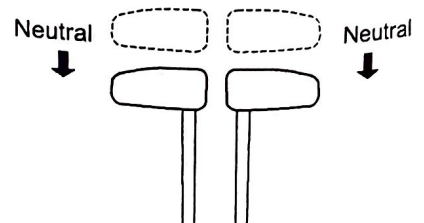

3.5 Steering

steering (turning the machine)

⚠ WARNING

- Never turn the machine on a slope to prevent it from overturning or skidding.
- Never turn at high speed and spin-turn on concrete or asphalt roads to prevent machine hunting.
- Never turn at high speed on rough terrain.

To steer the machine, operate the travel levers.

IMPORTANT

- Be extremely careful that the turning radius of the machine varies depending on whether the wagon is in loaded or unloaded state, and on the road surface condition.
- Do not turn the machine too sharply.

Operate the two travel levers (1) as follows:

■ Steering the machine when it is not traveling

To turn left, push the right travel lever forward and start traveling forward to the left. Pull the right travel lever back and start traveling in reverse to the left.

Note:

To turn right, operate the left travel lever in the same manner as above.

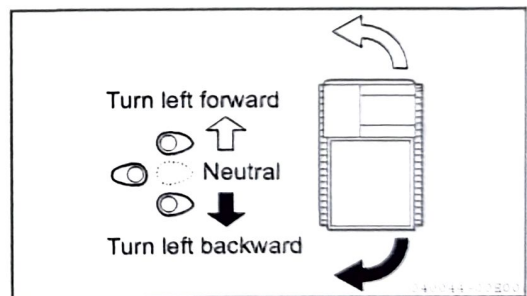
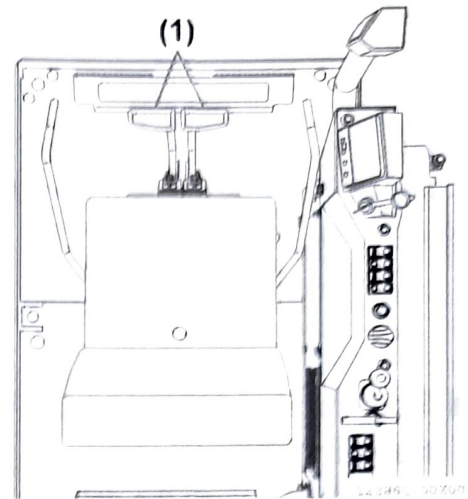

■ **Steering the machine while traveling**
(the left and right travel levers are both tilted in the same direction)

To turn left, return the left travel lever to the neutral position.

Note:

To turn right, return the right travel lever to the neutral position.

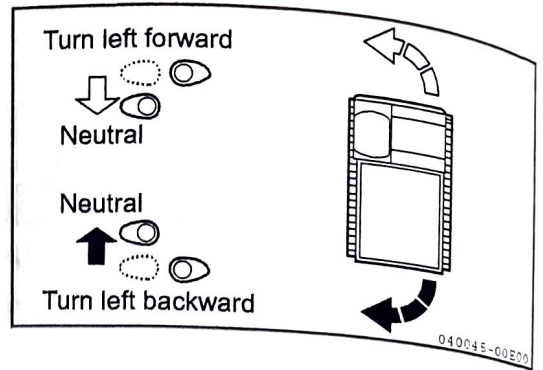

■ **Spin-turning the machine when it is not traveling**

To spin-turn left, push the right travel lever forward while pulling the left travel lever back.

Note:

To spin-turn right, push the left travel lever forward while pulling the right travel lever back.

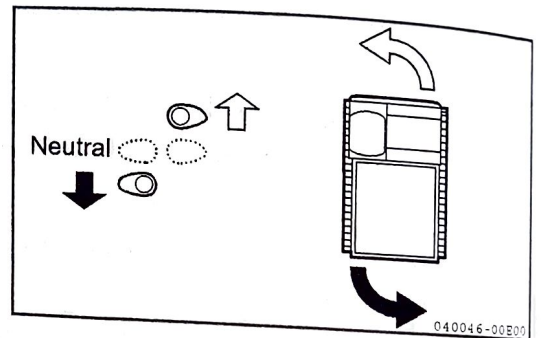

3.6 Stopping the machine

⚠ CAUTION

Do not stop the machine suddenly but provide a safety margin.

⚠ WARNING

- Park on solid, level ground.
- Do not park on a slope. If it is unavoidable to park on a slope, place solid blocks of wood behind the crawlers.

⚠ WARNING

- Do not touch the control levers accidentally. Otherwise, the implement or the machine may move unexpectedly, causing serious bodily injury.
- Whenever leaving the operator's seat, be sure to place the lock levers securely in the lock position and remove the starter switch key.

1. Set the right and left travel levers (1) to the neutral position to stop the machine.

2. Return the accelerator dial (2) to the "LOW IDLING" position.

3. Set the lock levers (3) to the lock position.

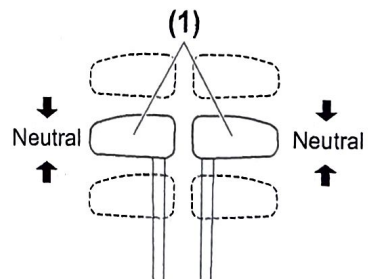
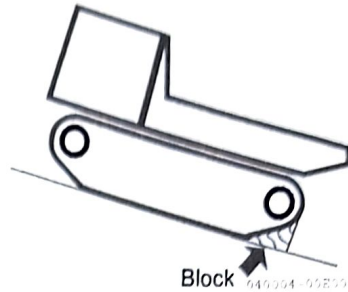

122862-00EN00

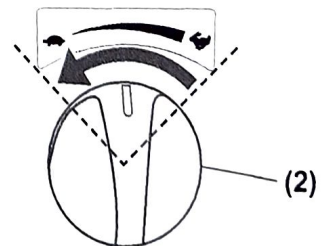

122863-00X00

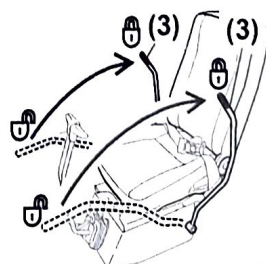

122856-00X01

3.7 Dumping the wagon

⚠ WARNING

- Check the area around the machine for safety before beginning to dump the wagon.
- Do not operate the dump lever while traveling.

⚠ CAUTION

When traveling with the machine, keep the wagon completely lowered. If the machine travels with the wagon dumped halfway, the machine could be damaged.

1. Pull up the dump lock lever (1) to set it to the unlock position before dump operation.

2. Operate the dump lever (2) to dump the wagon. To control the dump speed, operate the accelerator dial.

3. After completing the dump operation, set the dump lever (2) to the lower position to lower the wagon completely.

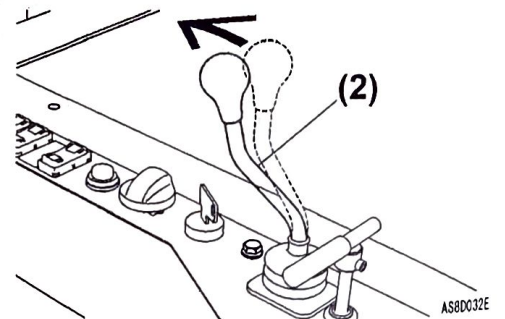
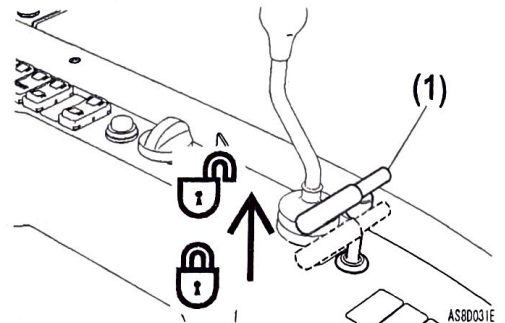
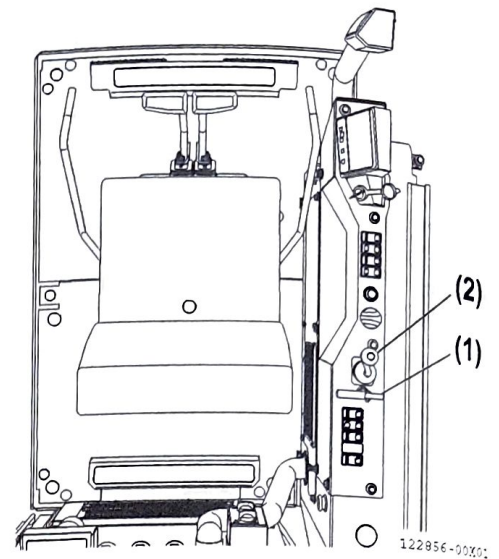

3.8 Swinging the wagon (for the swing wagon type)

⚠ WARNING

- Before swinging, make sure that there are no people or obstacles within the swing range of the wagon.
- Do not operate the dump lever while traveling.

⚠ CAUTION

When traveling with the machine, keep the wagon parallel to the crawlers. If the machine travels with the wagon swung to the right or the left, the machine will be unstable.

1. Pull up the dump lock lever (1) to the unlock position before swing operation.

2. Operate the dump lever (2) to swing the wagon. To control the swing speed, operate the accelerator dial.

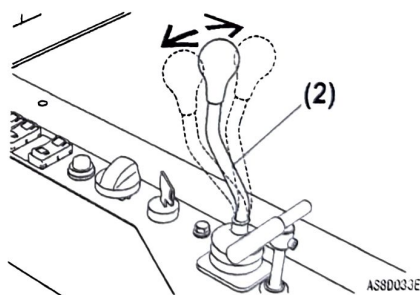
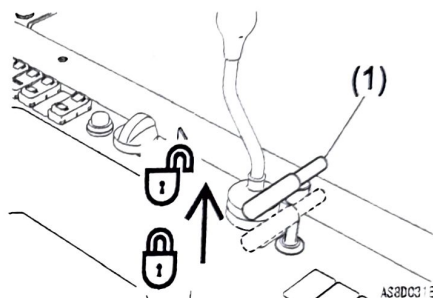
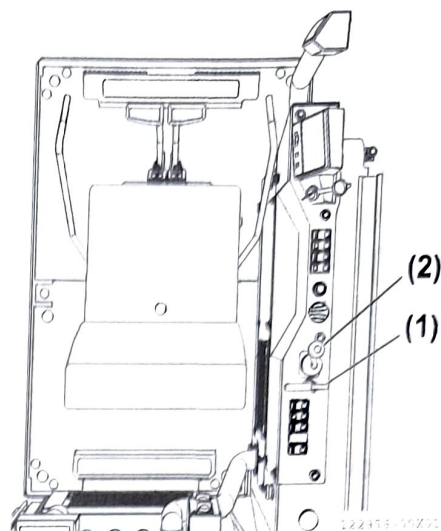

3.9 Precautions for working

■ Precautions for traveling

Driving over a stone or a stump subjects the machine (especially undercarriage) to a shock, which may cause damage to the machine.

Avoid such obstacles by driving around them, or removing them.

If driving over them is unavoidable, reduce speed, and drive over the obstacles with the center of the track shoes.

■ Allowable water depth

IMPORTANT

When driving out of water, if the machine goes up a slope at an angle of more than 10 degrees, the front frame may submerge too deeply in the water, which may damage the radiator fan. Avoid this if possible when driving out of water.

The limit of the water depth in which the machine can be used in is up to the center of the travel reduction gear.

Apply a generous amount of grease to the parts (especially the portions listed below) that have been submerged in the water for a long time until the used grease is extruded out of the bearings.

- Track roller vibrating plate portion
- Wagon support pins
- Dump cylinder support pins

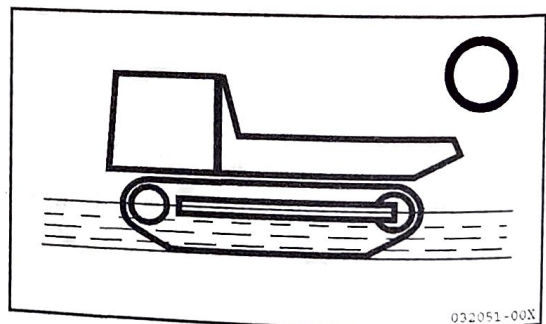
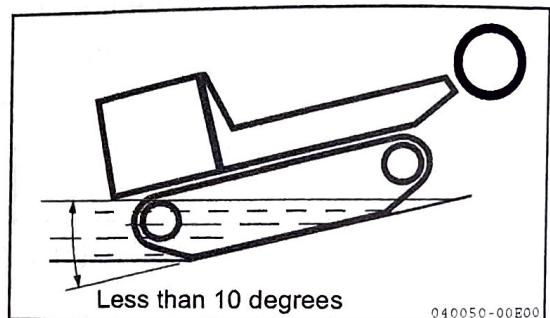
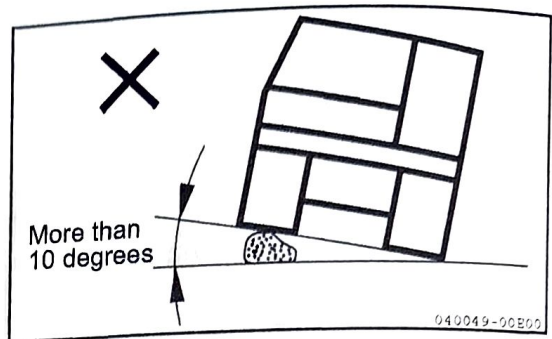

3.10 Precautions for going up and down a slope

■ Going up and down a slope

⚠ WARNING

- Run the machine at low speed on a slope of 9 to 10 degrees or more, with the automatic speed change switch turned off (for traveling at low speed) and the engine throttled down to medium speed or lower.
- When driving over obstacles such as foot paths, drive the machine slowly.
- Never turn on or traverse a slope.
- Descend to flat ground to make a course change.
- Recognize that the machine may roll over when dumping the wagon on a slope. Do not dump the wagon toward the downward side of the slope. If dumping is unavoidable, first lay earth on the slope to maintain the machine as horizontal as possible, then dump the wagon.
- Do not travel on a slope of 20 degrees or more, as the machine may upset.
- Never exceed the loading capacity when going down a slope. If the machine goes down a slope carrying an excessive load, engine speed will increase excessively leading to overrun, which may cause the machine to go out of control or cause damage to the machine.

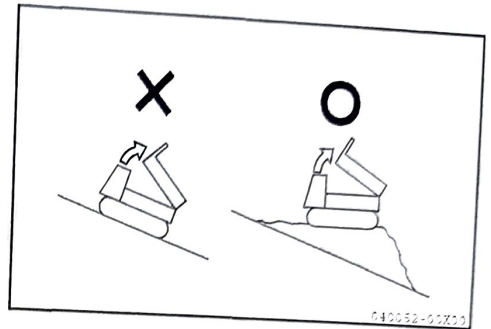
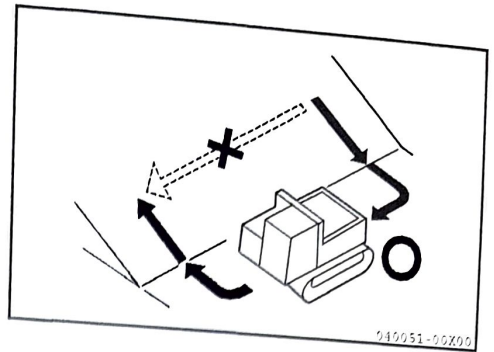

1. To go down a steep slope, run the machine at low speed with the automatic speed change switch turned off, the travel levers placed slightly forwards and the engine throttled down to medium speed or lower with the accelerator dial.

To go up or down a slope of 15 degrees or more, run the machine at low engine speed if the wagon is unloaded.

2. When going down a slope, run the machine in the posture as shown in the figure at the right.

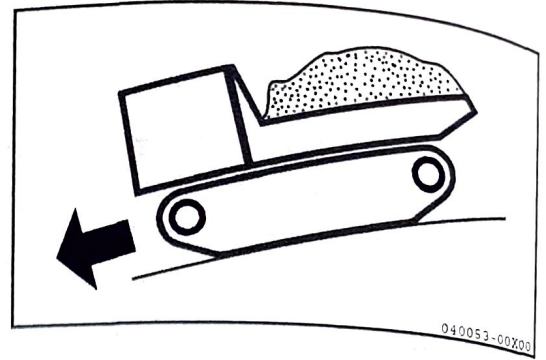

■ **Braking when going down a slope**

When going down a slope, you can automatically brake the machine by setting the travel levers to the neutral position.

■ **When the crawler is slipping**

If the crawler is slipping while the machine is going up a slope, stop traveling, descend the slope and take the other route.

3.11 Parking the machine

⚠ CAUTION

Do not stop the machine suddenly but provide a safety margin.

⚠ WARNING

- Park on solid, level ground.
- Do not park on a slope. If it is unavoidable to park on a slope, place solid blocks of wood.

⚠ WARNING

- Be careful not to set the lock levers to the unlock position accidentally. Otherwise, the machine may move unexpectedly, causing a serious accident.
- When leaving the operator's seat, be sure to place the lock lever securely in the lock position and remove the starter switch key.

1. Set travel levers (1) to the neutral position.
2. Return accelerator dial (2) to the low idle position to run the engine at low idle.

3. Set the lock levers (3) to the lock position.
4. Lower the wagon and then lock dump lever (4).

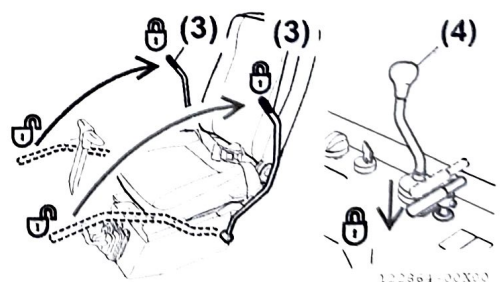
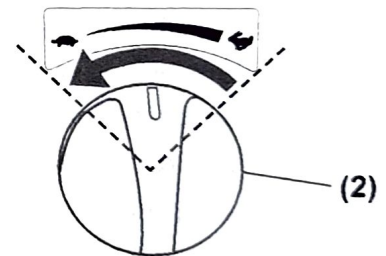
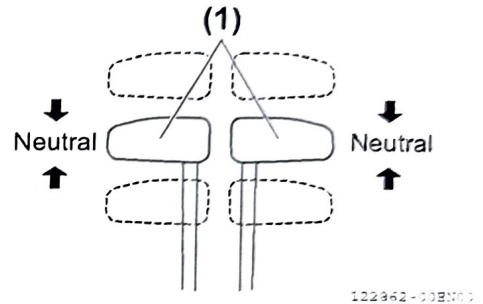
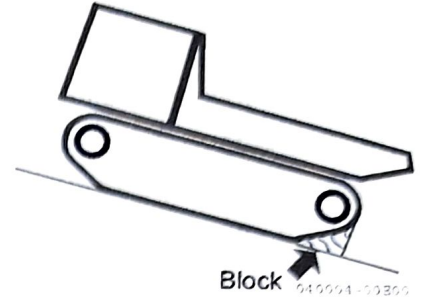

3.12 Checks required after operation

Check the coolant temperature with water temp. meter (1), the fuel level with fuel meter (3) and the urea level with urea level meter (4) on the LCD monitor. In addition, check that symbols (2) are not illuminated.

However, the following symbols will remain illuminated in the following situations:

- (5): The wagon is in the dump position.
- (6): The travel speed change switch is in the high speed position.
- (7): The turn signal switch is on.
- (8): The wagon is parallel with the crawlers.
- (9): The lock levers are in the lock position.

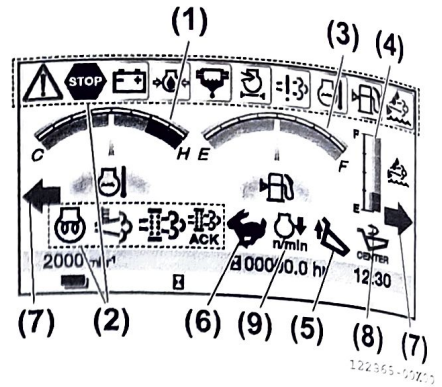

3.13 Stopping the engine

IMPORTANT

- Stopping the engine after rotation at high speed may shorten the engine life. Do not stop the engine suddenly except in case of emergency.
- If the engine is overheated, do not stop the engine immediately. Gradually lower the engine temperature by rotating the engine at medium rotational speed before stopping the engine.

1. Idle the engine for approximately 5 minutes with no load.

(The engine temperature gradually lowers.)

Note:

Stopping a turbo-charged engine immediately after running it could cause the lubricated portions of the turbo charger to dry up due to high temperatures, possibly resulting in a failure of the turbo charger.

2. To stop the engine, turn the starter switch key to the "OFF" position.

3. Take the starter switch key out of the starter switch.

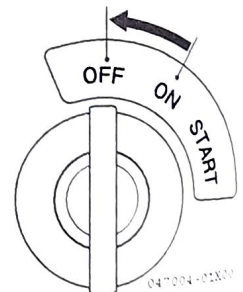

3.14 Inspection requirements after stopping the engine

1. Check oil and water for leaks, and visually inspect the wagon, the machine, and the undercarriage by walking around them.

If there are any leaks of oil or water, or any observed abnormality, take corrective action.

2. Completely fill the fuel tank.

3. Confirm that the engine compartment is free of any foreign matter.

Combustibles or dust in the engine compartment may cause a fire. Remove them, if any.

4. Remove mud adhering to the undercarriage of the machine.

3.15 Locking

Make sure that the following parts are locked:

- Fuel filler cap
- Side door (for cabin)
- Engine hood
- Side cover
- Battery cover
- Urea tank cover

Note:

The starter switch key is used to lock each of the parts listed above.