



OIL/NG/LP FIRED SPACE HEATER: BLAZE 200 D/G TURBO
WWW.CAMPOEQUIPMENT.COM



REPORT # 0367MH007S



Installation Instructions-Manual-Maintenance-Parts List

CAUTION: DO NOT TAMPER WITH HEATER OR ITS CONTROLS. CALL A QUALIFIED SERVICE TECHNICIAN

Retain manual for future reference June 17, 2016

CERTIFIED FOR USE IN CANADA AND THE U.S.A.



WARNING: FIRE, BURN,
INHALATION AND EXPLOSION HAZARD.

KEEP SOLID COMBUSTIBLES SUCH
AS BUILDING MATERIALS, PAPER OR
CARDBOARD A SAFE DISTANCE AWAY
FROM THE HEATER AS RECOMMENDED
BY THE INSTRUCTIONS.

NEVER USE THE HEATER IN SPACES
WHICH DO OR MAY CONTAIN VOLATILE
OR AIRBORNE COMBUSTIBLES,
SOLVENTS, PAINT THINNER, DUST
PARTICLES OR UNKNOWN CHEMICALS.



GENERAL HAZARD WARNING:

FAILURE TO COMPLY WITH THE
PRECAUTIONS AND INSTRUCTIONS
PROVIDED WITH THIS HEATER CAN
RESULT IN DEATH, SERIOUS BODILY
INJURY AND PROPERTY LOSS OR
DAMAGE FROM HAZARDS OF FIRE,
EXPLOSION, BURN, ASPHYXIATION,
CARBON MONOXIDE POISONING,
AND/OR ELECTRICAL SHOCK.

ONLY PERSONS WHO CAN UNDERSTAND
AND FOLLOW THE INSTRUCTIONS
SHOULD USE OR SERVICE THIS HEATER.

IF YOU NEED ASSISTANCE OR
HEATER INFORMATION SUCH AS AN
INSTRUCTION MANUAL, LABEL, ETC.
CONTACT THE MANUFACTURER.

! WARNING !

**NOT FOR HOME OR RECREATIONAL VEHICLE USE
POSITION HEATER PROPERLY BEFORE USE
FOR EITHER INDOOR OR OUTDOOR USE**

**ADEQUATE VENTILATION
MUST BE PROVIDED**

CAMPO EQUIPMENT CO. LTD. (ECOBLAZE)

6 Carson Court, Brampton, ON, CANADA, L6T 4P8

Tel: (905) 793-2525 | Fax: (905) 793-8768 | www.campoequipment.com Page | 2

READ INSTRUCTIONS PRIOR TO STARTING HEATERS

THIS HEATER IS DESIGNED AND APPROVED FOR USE AS A CONSTRUCTION HEATER UNDER STANDARD ANSI Z83.7-2011/CSA2.14-2011, UL 733-2013 and CAN/CSA B140.8-1967(R2015)

THESE HEATERS ARE SUITABLE FOR OUTDOOR USE

THE REQUIREMENTS OF LOCAL AUTHORITIES HAVING JURISDICTION SHALL BE FOLLOWED

BLAZE 200 G TURBO

NOTE: THIS HEATER IS INTENDED FOR USE PRIMARILY AS TEMPORARY HEATING OF BUILDINGS UNDER CONSTRUCTION, ALTERATION OR REPAIR

THIS UNIT IS APPROVED FOR USE WITH PROPANE OR NATURAL GAS. NEVER ATTEMPT TO BURN GARBAGE OR PAPER IN THE HEATER AND REMOVE ALL PAPER AND RAGS FROM AROUND THE HEATER. FOR YOUR SAFETY, DO NOT STORE OR USE GASOLINE OR OTHER FLAMMABLE LIQUIDS OR VAPOURS IN THE VICINITY OF THE HEATER.

DO NOT TAMPER WITH THE HEATER AND CONTROLS! THE HEATER MUST BE SERVICED BY QUALIFIED SERVICE PERSONNEL.

WARNING: THOSE WHO INSTALL THE HEATER MUST HAVE THE TRAINING AND EXPERIENCE NECESSARY TO DO SO. READ THIS MANUAL CAREFULLY. FAILURE TO PROPERLY INSTALL AND SETUP THE HEATER COULD RESULT IN PROPERTY DAMAGE, PERSONAL INJURY, OR LOSS OF LIFE. THE QUALIFIED SERVICE PERSONNEL PERFORMING THIS WORK ASSUMES A SERIOUS RESPONSIBILITY FOR THE CORRECT INSTALLATION, SETUP, AND START-UP OF THE HEATER.

THIS HEATER IS DESIGNED AND APPROVED FOR USE AS A CONSTRUCTION HEATER IN ACCORDANCE WITH STANDARD ANSI Z83.7-2011/CSA2.14-2015. CHECK WITH YOUR LOCAL FIRE SAFETY AUTHORITY IF YOU HAVE QUESTIONS ABOUT APPLICATIONS.

WARNING: INTENDED USE IS PRIMARILY THE TEMPORARY HEATING OF BUILDINGS UNDER CONSTRUCTION, ALTERATION, REPAIR OR EMERGENCIES ONLY.

WARNING: ALWAYS PROVIDE ADEQUATE VENTILATION. MINIMUM ACCEPTABLE VENTILATION REQUIRED: 1 SQ. IN. OF FRESH AIR MUST BE SUPPLIED FOR EVERY 1000 BTU/H OF HEAT.

WARNING: THIS HEATER SHALL BE INSTALLED SUCH THAT IT IS NOT DIRECTLY EXPOSED TO WATER SPRAY, AND/OR DRIPPING WATER.

CHECK WITH YOUR LOCAL FIRE SAFETY AUTHORITY IF YOU HAVE QUESTIONS ABOUT APPLICATIONS

THESE INSTRUCTIONS HAVE BEEN THOROUGHLY WRITTEN, BUT THEY CANNOT COVER EVERY PECULIAR INSTALLATION AND CONTINGENCY. THEREFORE IF THERE IS ANY DOUBT AS TO

INTERPRETATION OF ANY REQUIREMENTS, CONTACT YOUR LOCAL AUTHORITY HAVING JURISDICTION, YOUR LOCAL DISTRIBUTOR, OR THE FACTORY.

INSTALLATION REGULATIONS:

- 1.) THE INSTALLATION OF THE UNIT SHALL BE IN ACCORDANCE WITH THE REGULATIONS OF THE AUTHORITIES HAVING JURISDICTION.

WIRING: ALL INTERNAL WIRING OF THE HEATER IS COMPLETED BY THE MANUFACTURER. ALL EXTERNAL WIRING MUST CONFORM TO EXISTING ELECTRICAL CODES AS LAID DOWN BY THE AUTHORITIES HAVING JURISDICTION.

THE INSTALLATION OF THIS HEATER FOR USE WITH NATURAL GAS SHALL CONFORM WITH LOCAL CODES OR, IN THE ABSENCE OF CODES, WITH THE NATIONAL FUEL GAS CODE ANSI Z223.1/NFPA 54 AND THE NATURAL GAS AND PROPANE INSTALLATION CODE, CSA B149.1-00. THIS HEATER MUST BE INSTALLED BY A QUALIFIED GAS TECHNICIAN, FOLLOWING LOCAL CODES PUBLISHED BY THE AUTHORITY HAVING JURISDICTION. ALL INSTALLATIONS PERFORMED IN THE STATE OF MASSACHUSETTS MUST BE COMPLETED BY A QUALIFIED PLUMBER AND GAS FITTER OF THE STATE OF MASSACHUSETTS.

THE INSTALLATION OF THIS HEATER FOR USE WITH A PROPANE TANK OR CYLINDER SHALL CONFORM WITH LOCAL CODES OR IN THE ABSENCE OF LOCAL CODES, WITH THE STANDARD FOR THE STORAGE AND HANDLING OF LIQUEFIED PETROLEUM GASES, ANSI/NFPA 58 AND THE NATURAL GAS AND PROPANE INSTALLATION CODE, CSA B149.1

THIS HEATER MUST BE LOCATED AT LEAST 10FT (3M) FROM ANY PROPANE GAS CYLINDER.

THIS HEATER SHALL NOT BE DIRECTED TOWARD ANY PROPANE GAS CONTAINER WITHIN 20FT (6M).

OTHER STANDARDS GOVERN THE USE OF FUEL GASES AND HEAT PRODUCING PRODUCTS IN SPECIFIC APPLICATIONS. YOUR LOCAL AUTHORITY CAN ADVISE YOU ABOUT THESE.

READ INSTRUCTIONS PRIOR TO STARTING HEATERS

BLAZE 200 D TURBO

THIS UNIT IS APPROVED FOR USE WITH NO. 1 AND NO. 2 FUEL OIL. NEVER USE GASOLINE OR CRANKCASE OIL WHICH MAY CONTAIN GASOLINE AS FUEL FOR THE HEATER. NEVER ATTEMPT TO BURN GARBAGE OR PAPER IN THE HEATER AND REMOVE ALL PAPER AND RAGS FROM AROUND THE HEATER. FOR YOUR SAFETY, DO NOT STORE OR USE GASOLINE OR OTHER FLAMMABLE LIQUIDS OR VAPOURS IN THE VICINITY OF THE HEATER.

FOR YOUR SAFETY DO NOT ATTEMPT TO START THE HEATER IF:

- 1.) EXCESS OIL HAS ACCUMULATED
- 2.) THE HEATER IS FULL OF VAPOUR
- 3.) THE COMBUSTION CHAMBER IS EXTREMELY HOT

DO NOT TAMPER WITH THE HEATER AND CONTROLS! THE HEATER MUST BE SERVICED BY QUALIFIED SERVICE PERSONNEL.

WARNING: THOSE WHO INSTALL THE HEATER MUST HAVE THE TRAINING AND EXPERIENCE NECESSARY TO DO SO. READ THIS MANUAL CAREFULLY. FAILURE TO PROPERLY INSTALL AND SETUP THE HEATER COULD RESULT IN PROPERTY DAMAGE, PERSONAL INJURY, OR LOSS OF LIFE. THE QUALIFIED SERVICE PERSONNEL PERFORMING THIS WORK ASSUMES A SERIOUS RESPONSIBILITY FOR THE CORRECT INSTALLATION, SETUP, AND START-UP OF THE HEATER.

THESE INSTRUCTIONS HAVE BEEN THOROUGHLY WRITTEN, BUT THEY CANNOT COVER EVERY PECULIAR INSTALLATION AND CONTINGENCY. THEREFORE IF THERE IS ANY DOUBT AS TO INTERPRETATION OF ANY REQUIREMENTS, CONTACT YOUR LOCAL AUTHORITY HAVING JURISDICTION, YOUR LOCAL DISTRIBUTOR, OR THE FACTORY.

IMPORTANT: IF YOU OBSERVE THE PRIMARY CONTROL IS LOCKED OUT, PUSH THE RED RESET BUTTON ONLY ONCE. IF THE BURNER DOES NOT RE-LIGHT, DO NOT PUSH THE BUTTON A SECOND TIME OR EXCESS OIL WILL ACCUMULATE IN THE COMBUSTION CHAMBER—CALL A QUALIFIED SERVICE PERSON.

INSTALLATION REGULATIONS:

- 1.) INSTALLATION SHOULD BE IN ACCORDANCE WITH ALL LOCAL AND NATIONAL REGULATIONS.
- 2.) IN CANADA USE THE CSA B139-1962 INSTALLATION CODE FOR OIL BURNING EQUIPMENT, FOR RECOMMENDED INSTALLATION PRACTICE.

WIRING: ALL INTERNAL WIRING OF THE HEATER IS COMPLETED BY THE MANUFACTURER. ALL EXTERNAL WIRING MUST CONFORM TO EXISTING ELECTRICAL CODES AS LAID DOWN BY THE AUTHORITIES HAVING JURISDICTION. IN CANADA, REFER TO CSA C22.1 CANADIAN ELECTRICAL CODE AND IN THE UNITED STATES AS OUTLINED IN THE BOCA CODE, OR THE NFPA 70 NATIONAL ELECTRICAL CODE.

WARNING: LACK OF COMBUSTION AIR CAN CAUSE A DIRTY FIRE, ODOURS IN ENCLOSED SPACES, AND BACKDRAFTING, POTENTIALLY RESULTING IN NAUSEA OR ASPHYXIATION OF THE OCCUPANTS.

| BLAZE 200 D/G SPECIFICATIONS | BLAZE 200G-BECKETT (NG/LP) | BLAZE 200D-BECKETT (OIL) |
|------------------------------|----------------------------|------------------------------------------------------|
| Burner Make & Model | Beckett CG4 | Beckett AFG |
| Voltage | 120V | 120V |
| Input (BTU/h) | 175,000 | NO.1 (172,599) @ 175 PSI NO.2 (175,000) @ 175 PSI |
| CFM/AMPS | 2,750/9 | 2,750/9 |
| MOTOR HP | .67 | .67 |

| | | |
|----------------------------------------------------|--------------------------------------------------------------------------------------------------------------------|-------------------------------------------------|
| Ductability (Return/Supply) Static Pressure | Max 150ft ducting overall 50ft/150ft upto 5" | Max 150ft ducting overall 50ft/150ft upto 5" |
| Outlet Duct Size | 1 X 12" | 1 X 12" |
| Inlet Duct Size | 1 X 12" | 1 X 12" |
| Gas Conversion | Easy switch over Blue handle Ball Valve on Gas manifold. Closed position: Propane Open position: Natural Gas | N/A |
| Manifold pressure "W.C. | 3.5"NG or 3.5"LP (Pressure to be set before NG/LP switchover valve) | N/A |
| Minimum/Maximum Supply Pressure "W.C. | 6/13 FOR NG AND LP OPERATION | N/A |
| Nozzle | N/A | 1 X 70B |
| Pump Pressure | N/A | 175 |
| GPH | N/A | 1.428 |
| Fuel | NG or LP | No. 1 or No. 2 / Kerosene or Furnace Oil |
| Head Setting | N/A | N/A |
| Air Setting (Beckett-Shutter/Band) | 9/2 | 4/2 |
| APPROVAL AGENCY | OMNI | OMNI |
| DRY WEIGHT (lbs.) | 250 | 300 |

Dimensions48.51" x 30.6" x
40.1"

48.51" x 30.6" x 40.1"

FLUE SIZE

4"

4"

CONNECTING THE CYLINDER

Clearance to LP containers: 10 feet (3M)

IF CYLINDERS ARE USED TO SUPPLY THE HEATER, NO CYLINDERS SMALLER THAN 100 LB CAPACITY SHALL BE USED. THESE CYLINDERS MUST SUPPLY A VAPOUR WITHDRAWAL ONLY.

- 1.) ALL CYLINDER CONNECTIONS MUST BE MADE USING A WRENCH TO TIGHTEN THE POL FITTING.
- 2.) BE SURE THAT THE CYLINDER VALVE IS IN THE CLOSED POSITION WHEN CONNECTING OR DISCONNECTING THE CYLINDER.
- 3.) PROPER PROCEDURE FOR GAS LEAK TESTING: A SOAP AND WATER SOLUTION MUST BE APPLIED TO ALL CONNECTIONS IN ORDER TO LEAK CHECK THE SYSTEM.
- 4.) THE HOSE ASSEMBLY MUST BE VISUALLY INSPECTED PRIOR TO EACH USE OF THE HEATER.

THE GAS MUST BE TURNED OFF AT THE PROPANE SUPPLY CYLINDER(S) WHEN THE HEATER IS NOT IN USE. WHEN THE HEATER IS TO BE STORED INDOORS, THE CONNECTION BETWEEN THE PROPANE SUPPLY CYLINDER(S) AND THE HEATER MUST BE DISCONNECTED AND THE CYLINDERS REMOVED FROM THE HEATER AND STORED IN ACCORDANCE WITH STANDARDS FOR THE STORAGE AND HANDLING OF LIQUIFIED PETROLEUM GASES, ANSI/NFPA 58 AND CSA B149.1, NATURAL GAS AND PROPANE INSTALLATION CODE.

PIPING: THIS HEATER MUST BE INSTALLED BY A QUALIFIED GAS TECHNICIAN FOLLOWING LOCAL CODES PUBLISHED BY THE AUTHORITY HAVING JURISDICTION. SIZING OF SUPPLY PIPING MUST BE DETERMINED USING THE LENGTH OF PIPE RUN AS WELL AS TOTAL BTUH RATING OF THE APPLIANCE(S). APPROPRIATE PIPING TABLES MUST BE USED TO DETERMINE SIZE OF SUPPLY PIPING DEPENDANT ON THE LENGTH OF RUN FROM SOURCE.

CONNECTING TO AN EXTERNAL FUEL TANK (BLAZE 200 D TURBO)

Beckett AFG is fitted with 3/8" SAE male fittings and is set up for a 2 line system to eliminate priming. Ensure fuel tank has a supply line and a return line and connect the supply line to the 3/8" SAE fitting on the inlet side of the fuel filter and the return line to the return fitting located on the

Beckett Burner pump. For a 1 line system remove bypass plug located on inlet port of Beckett Pump and just connect fuel line to inlet side of fuel filter.

FUEL (BLAZE 200 G TURBO)

THIS HEATER WILL OPERATE ON PROPANE **OR** NATURAL GAS—**NOT BOTH**. THE MANIFOLD PRESSURES ARE LISTED ON THE APPROVAL LABEL. TO DETERMINE WHICH FUEL TO USE SEE RATING PLATE. **DO NOT** ATTEMPT TO USE THE HEATER WITHOUT CONSULTING THE RATING PLATE.

NOTE: THE PROPER POSITION ON THE EASY SWITCH OVER BLUE HANDLE BALL VALVE MUST BE USED AND RATING PLATE MUST REFLECT THE FUEL THE HEATER IS BURNING. **DO NOT** OPERATE THE HEATER WITHOUT CONSULTING THE RATING PLATE.

HEATER CONVERSION MUST BE DONE BY A QUALIFIED TECHNICIAN AND RATING PLATE MUST REFLECT ANY CHANGE.

THIS UNIT HEATER IS EQUIPPED FOR NATURAL GAS OR LP GAS. THIS UNIT HEATER IS EQUIPPED WITH ORIFICES SIZED FOR OPERATION WITH NATURAL OR LP GAS VIA THE EASY SWITCH OVER BLUE HANDLE BALL VALVE. FOR CONVERSION TO LP (OR NATURAL) GAS SEE INSTRUCTION PLATE ON THE APPLIANCE.

Easy switch over Blue handle Ball Valve on Gas manifold.

Closed position: Propane

Open position: Natural Gas

HOSES

ALL HOSES USED TO CONNECT THIS HEATER TO FUEL SUPPLY MUST BE TYPE 1 APPROVED PROPANE/NATURAL GAS HOSE ASSEMBLIES.

ELECTRICAL

WARNING: ELECTRICAL GROUNDING INSTRUCTIONS

THIS APPLIANCE IS ABLE IS TO RECEIVE 1 PHASE POWER.

120V SUPPLY MUST BE AVAILABLE.

INSTALLATION

12/3 AWG UPTO 50FT

10/3 AWG BEYOND 50FT

NOTE: IF ANY OF THE ORIGINAL WIRE AS SUPPLIED WITH THE APPLIANCE MUST BE REPLACED, IT MUST BE REPLACED WITH TYPE TEW 14GA WIRE OR ITS EQUIVALENT.

| ELECTRICAL SYSTEM | BLAZE 200 D/G |
|--------------------------------------------------|--------------------------|
| Volts-Hertz-Phase | 120-60-1 |
| Full Load (Amps) | 9 |
| Max fuse size in AMPS with time delay | 15 |

The electrical grounding of the heater shall be in compliance with the National Electrical Code, ANSI/NFPA 70, or the CSA C22.1, Canadian Electrical Code, Part I

Blaze 200D Turbo Schematic
(Beckett AFG Oil Burner)

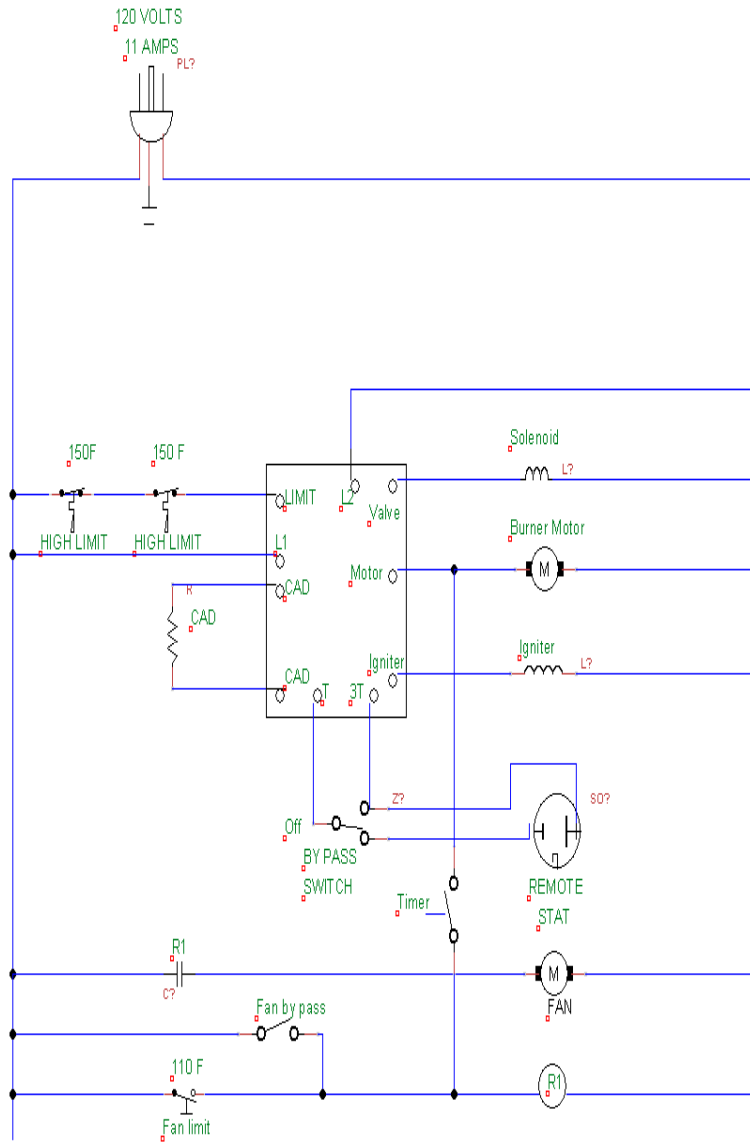

| | | |
|-----------------------------------------------|--------------|--------|
| Title | | |
| 200D TURBO INDIRECT FIRE HEATER | | |
| Author | | |
| | | |
| File | Document | |
| ds\Blaze 200D Turbo Schematic Rev 0 Aug 16 16 | | |
| Revision | Date | Sheets |
| 1.0 | AUG. 10-2016 | 1 of 1 |

Blaze 200G Turbo Schematic (Beckett CG4 Burner)

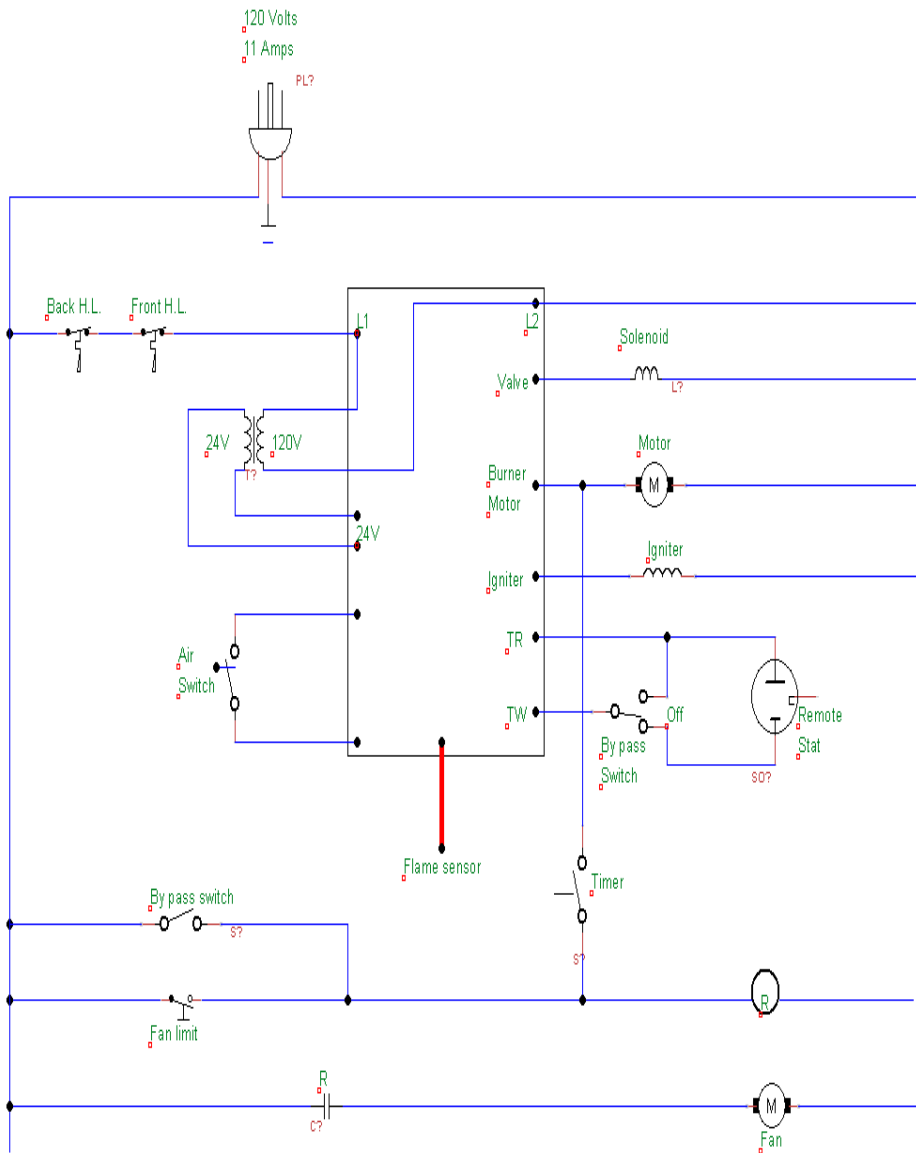

| | | |
|-----------------------------------------------|----------------|----------|
| Title | | |
| 200G TURBO INDIRECT FIRE HEATER | | |
| Author | | |
| File | | Document |
| js\Blaze 200G Turbo Schematic Rev 0.Aug 16 16 | | |
| Revision | Date | Sheets |
| 1.0 | August 16-2016 | 1 of 1 |

SEQUENCE OF OPERATION FOR BLAZE 200 D/G TURBO

With “Selector Switch” in “ON” position and selector switch in “STAT ON” position and remote thermostat plugged into receptacle:

- 1: Remote Thermostat senses a drop in temperature and the ignition control module is energized.
- 2: The module performs a safe start check and the burner and spark generator start. Burner lights, ignition stops, and flame current is sensed.

For oil: the Genisys primary control contacts close, the burner motor and ignitor are energized after a 15 second delay. The primary control energizes the pump solenoid valve and flame is established. The cad cell senses flame and the burner continues to fire.

- 3: Fan switch heats up to factory set point (110F) OR after Time Delay of 1 minute and circulating air blower starts.
- 4: When the remote thermostat senses space temperature at set point, the burner shuts down.
- 5: The circulating blower continues to operate until the air in the unit cools to the factory set point (80 °F) then turns off.

With selector switch in “BYPASS” position:

- 1: The module performs a safe start check and the burner and spark generator start.
- 2: Burner lights, ignition stops, and flame current is sensed.
- 3: Fan switch heats up to factory set point (110F) and circulating air blower starts.
- 4: When the selector switch is placed to the off position the burner shuts down.
- 5: The circulating blower continues to operate until the air in the unit cools to the factory set point (80F) then turns off.

OPERATING INSTRUCTIONS FOR BLAZE 200 D/G TURBO

STARTING HEATER

- 1.) ENSURE HEATER IS ON FLAT, LEVEL GROUND BEFORE STARTING, CANOPY AND FAN GUARDS MUST BE CLOSED.
- 2.) MAKE SURE “SELECTOR SWITCH” IS IN “OFF” POSITION.
- 3.) WIRE IN SUPPLY CORD TO 120V SUPPLY WITH GROUND.

INSTALLATION

12/3 AWG UPTO 50FT

10/3 AWG BEYOND 50FT

- 4.) TURN “SELECTOR SWITCH” TO “ON” POSITION.
- 5.) FOR THERMOSTAT OPERATION FLIP SELECTOR SWITCH TO “STAT ON” POSITION. IF YOU ARE NOT USING A THERMOSTAT FLIP SELECTOR SWITCH TO “BYPASS” POSITION.

Please Note: When using a generator for electrical supply, make sure the generator is properly grounded and is running at a 60HZ frequency. In the event that a generator is being used and the generator runs out of fuel, make sure the heater “SELECTOR SWITCH” is in the “OFF” position before restarting generator, failure to do so may damage heater.

STOPPING HEATER

- 1.) Close main gas supply valve while heater is operating or if operating heater with oil skip to # 2.)
- 2.) Flip “SELECTOR SWITCH” to “OFF” position. The supply fan will continue to operate until the heat exchanger has sufficiently cooled. Do not disconnect main power until supply fan has stopped running and “SELECTOR SWITCH” is on “OFF” position.
- 3.) Disconnect heater from gas supply OR disconnect fuel oil lines.

CAMPO EQUIPMENT CO. LTD. (ECOBLAZE)

6 Carson Court, Brampton, ON, CANADA, L6T 4P8

Tel: (905) 793-2525 | Fax: (905) 793-8768 | www.campoequipment.com Page | 12

WARNING BEFORE REMOVING ANY GUARDS OR SAFETIES TURN “SELECTOR SWITCH” TO “OFF” POSITION AND DISCONNECT THE MAIN POWER AS THE SUPPLY FAN WILL CYCLE AUTOMATICALLY.

IF HEATER FAILS TO START

- 1.) FOR BECKETT BURNERS 7575 or 7590 PRESS AND HOLD THE RED BUTTON ON THE BECKETT CONTROLLER LOCATED ON THE CONTROL PANEL FOR 3 SECONDS TO RESET. FOR 7590 PRESS RED BUTTON TO RESET.
- 2.) FOR GAS OPERATION CHECK GAS PRESSURE SUPPLY. SUPPLY AND MANIFOLD PRESSURE MUST FOLLOW THOSE ON RATING PLATE. FOR OIL OPERATION CHECK FUEL LEVEL, FILTER, NOZZLE AND SUCTION TUBING.
- 3.) ENSURE PROPER POWER SUPPLY AND WIRE GAUGE IS BEING USED.
- 4.) IF HEATER FAILS TO IGNITE AFTER 3 ATTEMPTS, CALL YOUR SUPPLIER FOR SERVICE.

NOTE: IF UNIT HAS BEEN RESET A NUMBER OF TIMES WITHOUT IGNITION -- DO NOT ATTEMPT TO START THE HEATER: CONTACT A QUALIFIED SERVICE TECHNICIAN.

NOTE: IN OIL OPERATION IF UNIT HAS BEEN RESET A NUMBER OF TIMES WITHOUT IGNITION THERE WILL BE AN ACCUMULATION OF OIL IN THE COMBUSTION CHAMBER! DO NOT ATTEMPT TO START THE HEATER: CONTACT A QUALIFIED SERVICE TECHNICIAN.

CAUTION

- 1.) **DO NOT SHUT OFF BY DISCONNECTING SUPPLY CORD. THE HEAT EXCHANGER SHOULD BE PROPERLY COOLED BEFORE POWER SHUTDOWN.**
- 2.) **ALWAYS MAINTAIN ADEQUATE FUEL SUPPLY.**
- 3.) **IF GAS BURNER IS INSTALLED HEATER IS FOR USE WITH PROPANE OR NATURAL GAS ONLY. SEE APPROVAL LABEL.**
- 4.) **DO NOT PLUG ANYTHING OTHER THAN THE THERMOSTAT INTO THE “REMOTE STAT” PLUG.**
- 5.) **FOLLOW ELECTRICAL REQUIREMENTS SHOWN ON RATING PLATE AND/OR ELECTRICAL REQUIREMENTS SECTION OF THIS MANUAL.**
- 6.) **IN OIL OPERATION DO NOT START THE HEATER WHEN EXCESS OIL HAS ACCUMULATED IN CHAMBER.**
- 7.) **IN OIL OPERATION DO NOT FILL TANK WHILE UNIT IS OPERATING.**
- 8.) **IN NO CASE SHOULD POWER CABLES BE SMALLER THAN WHAT IS STIPULATED ON NAMEPLATE AND INSTRUCTION MANUAL.**
- 9.) **IN OIL OPERATION DO NOT USE GASOLINE, CRANKCASE OIL OR HEAVIER THAN NO. 2 FURNACE OIL.**
- 10.) **DO NOT START THE HEATER WHEN THE CHAMBER IS HOT**
- 11.) **DO NOT FILL THE TANK WHILE THE UNIT IS OPERATING**
- 12.) **DO NOT TAMPER WITH THE UNIT. HAVE A COMPETENT SERVICE-TECHNICIAN MAKE ANY ADJUSTMENTS**
- 13.) **MAX OUTLET TEMPERATURE (U.S./CA) 280F**
- 14.) **AT INSTALLATION ELEVATIONS ABOVE 2000 FT (610m), THE APPLIANCE SHALL BE DERATED 4 PERCENT FOR EACH 1000 FT (305m) OF ELEVATION ABOVE SEE LEVEL**
- 15.) **SHOULD OVERHEATING OCCUR, OR THE GAS SUPPLY CONTROL SYSTEM FAIL TO SHUT OFF THE FLOW OF GAS, SHUT OFF THE MANUAL GAS VALVE TO THE UTILITY HEATER BEFORE SHUTTING OFF THE ELECTRICAL SUPPLY.**
- 16.) **DO NOT USE THIS UTILITY HEATER IF ANY PART HAS BEEN UNDER WATER. IMMEDIATELY CALL A QUALIFIED SERVICE TECHNICIAN TO INSPECT THE HEATER AND REPLACE ANY GAS CONTROL WHICH HAS BEEN UNDER WATER.**

ELECTRICAL REQUIREMENTS: 15 AMPS (1PH)

INSTALLATION INSTRUCTIONS

- 1.) The recommendations of local authorities having jurisdiction must be followed. For recommended installation practices refer to C.S.A. standard B139. (CANADA)
- 2.) When firing the unit in an enclosed area allow 1 square inch per thousand BTU's (refer to C.S.A. B139) to allow the free entry of the air required for operation.
- 3.) For electrical supply: 120V

INSTALLATION

12/3 AWG UPTO 50FT

10/3 AWG BEYOND 50FT

Do not operate the unit in partly ventilated areas without a flue pipe or in close proximity to combustible surfaces or materials. Non Combustible floor must extend 6 feet on all sides of the unit.

NOTE: Installation clearances are as follows:

| | |
|-------------------|---------|
| TOP | 3 feet |
| SIDES | 3 feet |
| BURNER END | 3 feet |
| DISCHARGE END | 10 feet |
| VENT CONNECTOR | 3 feet |
| COMBUSTIBLE FLOOR | 6 feet |

FLUE PIPE CONNECTIONS

VENT TO OUTDOORS

FOR INSTALLATION ON NON-COMBUSTIBLE FLOORS ONLY

When the heater is connected to a flue pipe the flue pipe shall terminate in a vertical section at least two feet long. Horizontal runs should have rise ratio of 1 in 10 away from the heater. *Where down drafts are liable to occur a vent cap should be used. All venting should correspond with the CSA B139 standard or local codes.*

CAUTION: HEATER FLUE TEMPERATURES CAN REACH 600F THEREFORE IT IS A RANGE THAT IS BOTH HAZARDOUS TO HUMANS AND HIGHER THAN THE AUTO-IGNITION TEMPERATURES OF MANY MATERIALS. THEREFORE EXERCISE CAUTION IN HEATER PLACEMENT AND THE USE OF AN INSULATED GUARD AND STACK IS HIGHLY RECOMMENDED.

Horizontal venting runs shall always terminate with a minimum 24" vertical.

NOTE: FOR OPTIMAL COMBUSTION PERFORMANCE A 30" C-VENT FLUE EXTENSION WITH RAIN CAP IS RECOMMENDED AT ALL TIMES.

Recommended chimney draft - .05 inches of water column

CAMPO EQUIPMENT CO. LTD. (ECOBLAZE)

6 Carson Court, Brampton, ON, CANADA, L6T 4P8

Tel: (905) 793-2525 | Fax: (905) 793-8768 | www.campoequipment.com Page | 14

INSTALLATION CLEARANCES

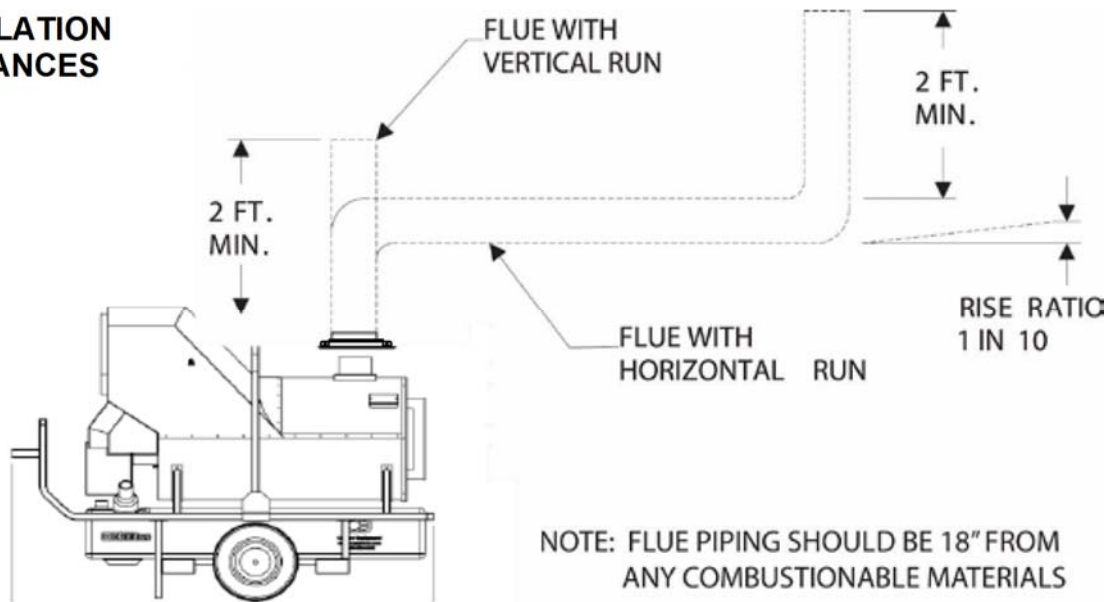

MAXIMUM ALLOWABLE DUCT LENGTHS BLAZE 200 D/G TURBO

RETURN DUCTS upto 50' (MAX 150FT OVERALL)

SUPPLY DUCTS upto 150' (MAX 150FT OVERALL)

**THIS HEATER IS FOR USE WITH AND WITHOUT DUCTWORK
WHEN USING DUCTWORK AVOID ANY KINKS OR SHARP BENDS.
INSUFFICIENT INLET AIR OR INSUFFICIENT DISCHARGE AIR WILL CAUSE
THE HEATER TO OVERHEAT.**

BLAZE 200 D/G TURBO MAINTENANCE INSTRUCTIONS

**WARNING EVERY CONSTRUCTION HEATER SHOULD BE INSPECTED
BEFORE EACH USE, AND AT LEAST ANNUALLY BY A QUALIFIED SERVICE
PERSON. INCORRECT MAINTENANCE MAY RESULT IN IMPROPER
OPERATION OF THE HEATER AND SERIOUS INJURY COULD OCCUR.**

HOSE ASSEMBLIES

The hose assemblies shall be visually inspected prior to each use of the heater. If it is evident there is excessive abrasion or wear, or the hose is cut, it must be replaced prior to the heater being put into operation. The replacement hose assembly shall be that specified by the manufacturer.

TEMPERATURE CONTROLLER AND THERMOCOUPLE

The temperature controller protocols should be checked every heating season to ensure the burner will shutdown if temperature exceeds 290F at the outlet duct. This can be accomplished by restricting the air flow through the unit. After tests are complete, remove restrictors as both inlet and outlet ducts must be open for proper operation.

The fan switch setting of 110F and time delay of 1 minute has been selected to allow for preheating of the heat exchanger to ensure that only heated air is allowed to enter the space. Upon satisfying the need for heat, the fan switch will continue to run the supply fan until the heat exchanger has cooled sufficiently. This feature will help prolong the life of the heat exchanger. The fan switch must be replaced if the fan motor does not shut off after the heat exchanger has cooled down.

Fan Switch Protocols

Fan Turns on at 110F OR time delay of 1 minute

There is a redundant 150F high limit switch.

During cool down the unit cools to 80F and then shuts down.

ELECTRICAL

Ensure all conduit (BX) connectors are tight. Open control panel door and burner compartment and check connections are tight and no frayed wires exposed.

FAN

Check for dust or dirt build up on blades. Run heater to check for fan vibration. Replace fan blade if vibration is noticeable. The flow of combustion and ventilation air must not be obstructed. Be sure to check the fan assembly and ensure that the motor and blade are operating properly.

MOTOR

No lubrication is necessary since the bearings are the sealed type. Clean motor of existing dust or dirt.

GAS TRAIN (annual basis)

Connect gas supply to gas train with gas safety shut-off valves closed. Spray all of gas train components including safety shut-off valves with soap and water solution to check for leaks. Open safety shut off valves on gas train and spray with soap and water solution to check for leaks.

HEAT EXCHANGER

If a smoky condition continues even after adjusting the air assembly, the heat exchanger should be thoroughly cleaned.

FUEL FILTER (OIL OPERATION)

Replace cartridge every six months of normal usage.

NOTE: FLOW OF COMBUSTION AND VENTILATION AIR CANNOT BE OBSTRUCTED

FLAME DETECTOR (OIL OPERATION)

When doing maintenance, turn on machine and run. After having machine run for a few minutes, press red button on primary control. Hold for one second and then release. If light flashes once or twice or three times, cad cell is functioning properly. If flashes four times, check alignment and proper flame. If correct a cleaning of the face of the cad cell with a soft non-abrasive cloth is recommended. If light flashes 4 times, follow above steps. If flashing four times persists, replace cad cell.

| LED FLASHES | CAD CELL RESISTANCE |
|-------------|---------------------|
| 1 | 0-400 Ohms |
| 2 | 400-800 Ohms |
| 3 | 800-1600 Ohms |
| 4 | >=1600 Ohms |

BURNER (OIL OPERATION)

The electrode spacing must be checked and adjusted, if necessary after every nozzle change. Nozzle should be replaced annually or sooner if burner cannot be set up to operate properly. Nozzle size and type are marked on the rating plate.

AFTER INSPECTION, A COMPLETE COMBUSTION TEST MUST BE PERFORMED AFTER EACH ANNUAL SERVICE OF THE UNIT TO MAINTAIN OPTIMUM PERFORMANCE AND RELIABILITY.

WARNING: TURN OFF THE FUEL SUPPLIES AND POWER BEFORE PERFORMING SERVICE WORK. THE 120V CIRCUIT IS A POTENTIAL ELECTROCUTION HAZARD.

COMBUSTION AIR ADJUSTMENTS

| BLAZE 200 D/G SPECIFICATIONS | BLAZE 200G-BECKETT (NG/LP) | BLAZE 200D-BECKETT (OIL) |
|---------------------------------------|--------------------------------------------------------------------------------------------------------------------|--------------------------|
| Gas Conversion | Easy switch over Blue handle Ball Valve on Gas manifold. Closed position: Propane Open position: Natural Gas | N/A |
| Manifold pressure "W.C. | 3.5"NG or 3.5"LP (Pressure to be set before NG/LP switchover valve) | N/A |
| Minimum/Maximum Supply Pressure "W.C. | 6/13 FOR NG AND LP OPERATION | N/A |
| Nozzle | N/A | 1 X 70B |

CAMPO EQUIPMENT CO. LTD. (ECOBLAZE)

6 Carson Court, Brampton, ON, CANADA, L6T 4P8

Tel: (905) 793-2525 | Fax: (905) 793-8768 | www.campoequipment.com Page | 17

| | | |
|------------------------------------|-----|-----|
| Pump Pressure | N/A | 175 |
| Head Setting | N/A | N/A |
| Air Setting (Beckett-Shutter/Band) | 9/2 | 4/2 |

NOTE: The above settings are approximations based upon clean equipment in proper working order. Combustion air adjustments will vary with location, altitude and type of fuel used.

BECKETT CG4 (THE BECKETT CG4 BURNER IS DESIGNED TO BE USED SOLELY WITH THE BECKETT 7590 GAS BURNER PRIMARY CONTROL AND THE 7474 GAS IGNITER).

- 1.) Loosen shutter and band and move to desired settings.
- 2.) Once desired settings are attained lock in place by tightening back shutter and band screws.

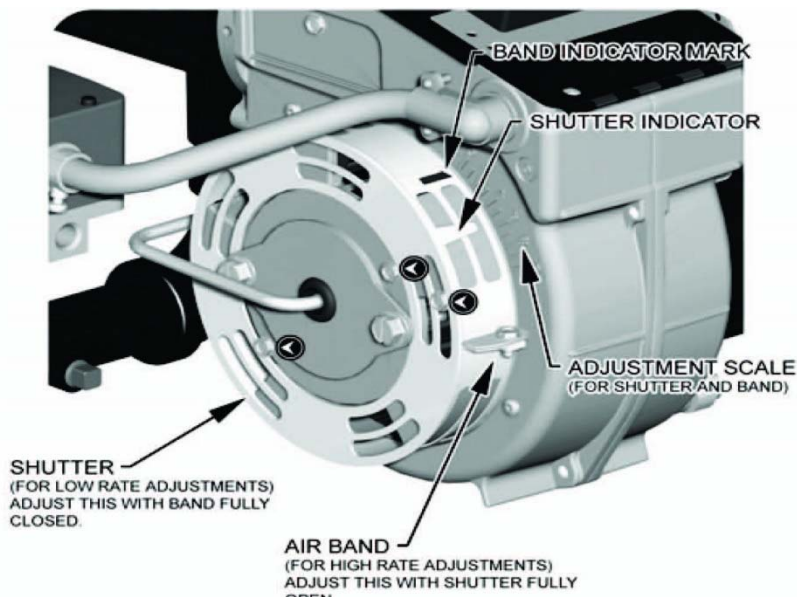

WARNING: LACK OF COMBUSTION AIR CAN CAUSE A DIRTY FIRE, ODOURS IN ENCLOSED SPACES, AND BACKDRAFTING, POTENTIALLY RESULTING IN NAUSEA OR ASPHYXIATION OF THE OCCUPANTS.

ALL AIR ADJUSTMENTS MUST BE DONE BY A QUALIFIED SERVICE TECHNICIAN

BECKETT AFG OIL BURNER

COMBUSTION AIR ADJUSTMENTS

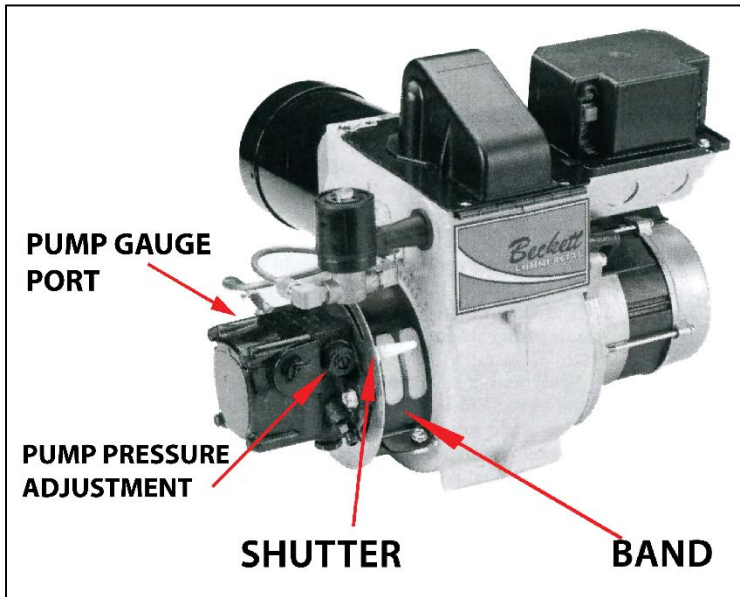

For proper combustion air adjustment a calibrated gas analyzer and smoke tester should be used to ensure complete combustion. Air adjustment should be made at the correct input and be adjusted to achieve 5% Oxygen and 12% CO₂. For optimum combustion efficiency the combustion air control should be set to provide no more than No. 1 smoke (Bacharach Scale). The Beckett burner has a calibrated air band, which will assist in adjusting the primary air for a good oil/air mixture. Adjust the air band supply by loosening lock screws and moving air shutter and if necessary the bulk air band. Begin by reducing the air until the unit begins to produce smoke. Increase air until no smoke is produced. Check for excessive heat build up in the heat exchanger. Insufficient air will cause flame impingement and reduced heat exchanger life. Increase air until heat build up has been eliminated. Check for proper ignition. Once satisfied re-tighten all screws and locking mechanisms.

This adjustment is to be carried out while the unit is operating and after 5 minutes of firing. Rotating the air bands on the burner housing makes the adjustment.

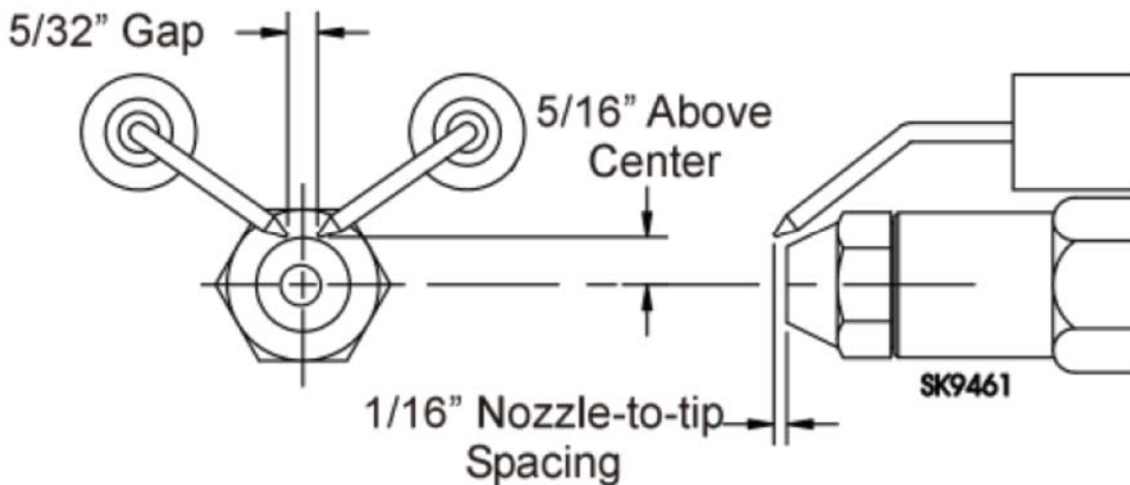

SETTING GAS FIRING RATES

- 1.) Choose BTU required and fuel supplied. For example 175,000 BTU and Natural Gas with the Beckett CG4.
- 2.) Adjust the manifold pressure to the recommended setting (3.5).
- 3.) Check nameplate for recommended air setting. A 9/2 air setting is recommended.
- 4.) Measure the carbon monoxide level and adjust air settings, if necessary, to regulate it to about 50 PPM for a starting point.
- 5.) Measure the O₂ or CO₂ at the 50 PPM level. For example, assume the O₂ is 1.5% (11% CO₂).

- 6.) Open the air adjustment until the O2 level is increased to 3% O2. This should reduce the CO level and provide a margin of reserve air to accommodate variable conditions.
- 7.) Sample the CO level again. It should be in the 0 to 50 PPM range—50 according to settings.
- 8.) Check the draft to ensure it still meets specifications. If a major change in draft is required, repeat the above steps.
- 9.) Perform any final adjustments and lock the air settings securely. Run the burner through several cycles to verify prompt ignition and stable burner operation.

SETTING OIL FIRING RATES

- 1.) Choose BTU required. For example 175,000 BTU..
- 2.) Check name plate for recommended pump pressure. 175 psi is recommended.
- 3.) Check nameplate for recommended air setting. A 4/2 air setting is recommended.
- 4.) Install a pressure gauge in pump gauge port and start the burner. Operate for 5 minutes until blower fan starts.
- 5.) Adjust pump pressure to 175 PSI.
- 6.) Adjust air band to 0 and adjust air shutter to 3.
- 7.) Check smoke and CO2 levels. Once attained, lock air band and shutter in place.
- 8.) Shut off burner, let unit cool down. The unit is now adjusted for 175,000 input BTU's.

THERMOSTAT OPERATION

The BLAZE 200 D/G TURBO can be operated with a thermostat control.

An optional remote thermostat is available for temperature control for the space being heated. To connect the heatstat, simply plug the heatstat into an extension cord and the extension cord into the outlet marked "REMOTE STAT". Make sure selector is in the "STAT ON" position. Place the remote thermostat into the space that is being heated. The unit will now shut down at the remote thermostat temperature setting.

BECKETT AFG PARTS BREAKDOWN

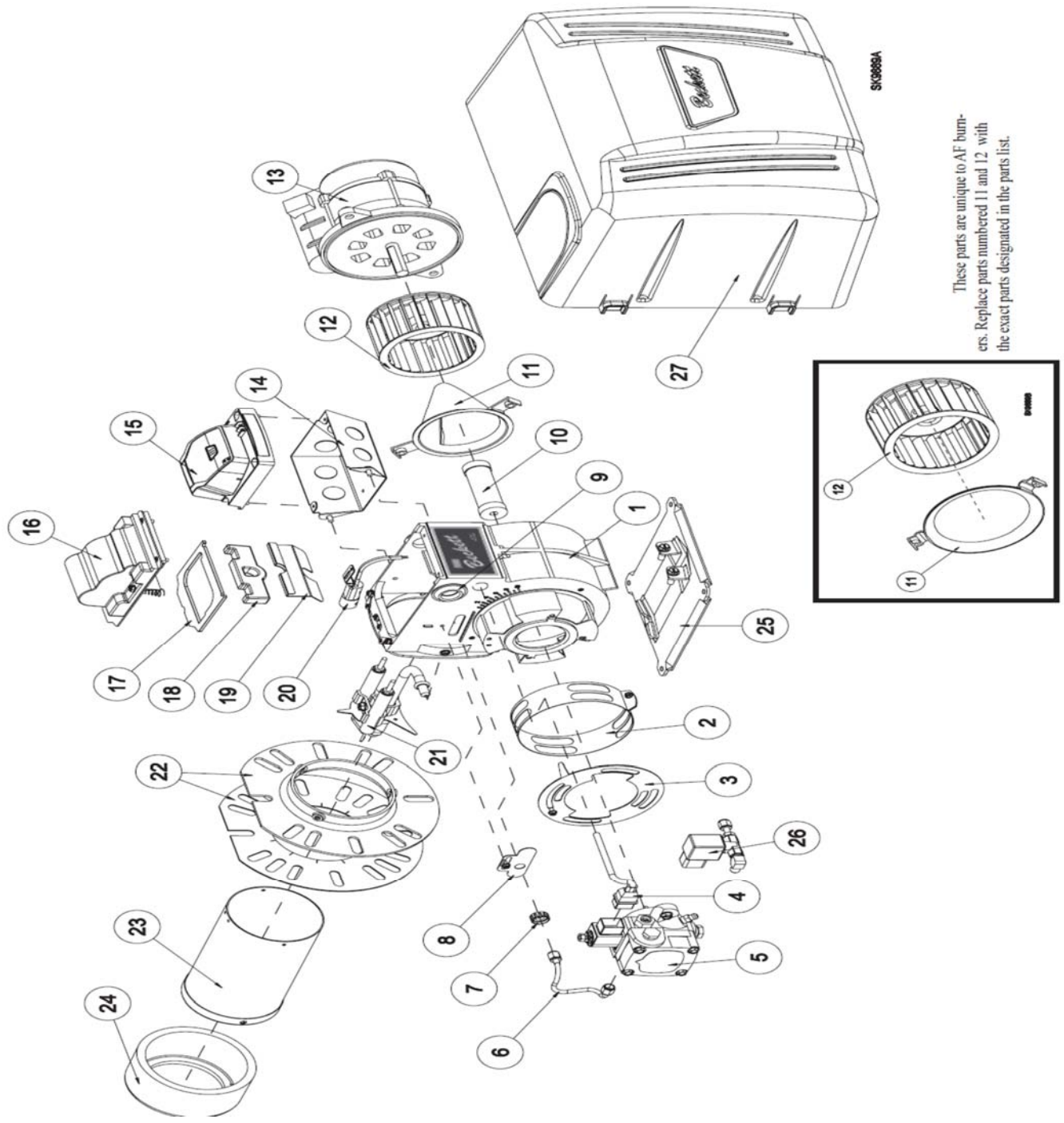

SK0869A

These parts are unique to AF burn-
ers. Replace parts numbered 11 and 12 with
the exact parts designated in the parts list.

| # | Part No. | Description |
|---------|--------------|-------------------------------------------|
| 17 & 18 | 51304 | Igniter Gasket Kit |
| 19 | 5880 | Low Firing Rate Baffle |
| 20 | 7006U | Cad Cell Detector |
| 21 | 5780 | Electrode Kit - F Head up to 9" |
| | 5782 | Electrode Kit - F Head over 9" |
| 22 | 5940 | Electrode Kit - M Head up to 9" |
| | 5432 3616 | Universal Flange w/ Gasket Gasket Only |
| 23 | Specify * | Air Tube Combination |
| 24 | Specify * | Heat Shield, Ceramic or Fiber |
| 25 | 5685 | Pedestal Kit |
| 26 | 2182602U | Solenoid Valve Kit (delay) |
| 27 | 52064xxU* | Cover |

| # | Part No. | Description |
|-----------|--------------|----------------------------------------|
| 1 | | Burner Housing Assembly |
| 2 | Specify* | Air Band - Specify # of slots |
| 3 | Specify* | Air Shutter - Specify # of slots |
| 4 | 21807U | Valve Cordset |
| Not Shown | 21887U | PD Timer Delay Cordset |
| 5 | 2184404U | CleanCut Pump |
| 6 | 5394 | Copper Oil Line - 8" |
| 7 | 3666 | Splined Nut |
| 8 | 3493 | Escutcheon (F & L1/L2 heads) |
| | 5941 | Head Adjusting Plate (V1 head) |
| 9 | 2139 | Hole Plug |
| 10 | 2454 | Coupling |
| 11 | 31231U (AFG) | Air Guide (AFG) |
| | 31841U (AF) | Air Inlet Bell (AF) |
| 12 | 2999U (AFG) | Blower Wheel (AFG) |
| | 2459U (AF) | Blower Wheel (AF) |
| 13 | 21805U | PSC Motor |
| | 4189 | Mounting Screws |
| 14 | 5770 | Electrical Box |
| 15 | 7505A | Replaces R7184A - Interrupted Ignition |
| | 7505B | Replaces R7184B - Pre-time |
| | 7505P | Replaces R7184P - Pre and Post-time** |
| 16 | 51771U | Igniter & Base Plate |

For replacement parts please contact Campo Equipment 1.866.323.0042