



EW60E

Volvo Excavators 5.15-6.07 t 47.3 kW



A passion for performance

At Volvo Construction Equipment, we're not just coming along for the ride. Developing products and services that raise productivity – we are confident we can lower costs and increase profits for industry experts. Part of the Volvo Group, we are passionate about innovative solutions to help you work smarter – not harder.

Helping you to do more

Doing more with less is a trademark of Volvo Construction Equipment. High productivity has long been married to low energy consumption, ease of use and durability. When it comes to lowering life-cycle costs, Volvo is in a class of its own.

Designed to fit your needs

There is a lot riding on creating solutions that are suited to the particular needs of different industry applications. Innovation often involves high technology – but it doesn't always have to. Some of our best ideas have been simple, based on a clear and deep understanding of our customers' working lives.



You learn a lot in 180 years

Over the years, Volvo has advanced solutions that have revolutionized the use of construction equipment. No other name speaks Safety louder than Volvo. Protecting operators, those around them and minimizing our environmental impact are traditional values that continue to shape our product design philosophy.

We're on your side

We back the Volvo brand with the best people. Volvo is truly a global enterprise, one that is on standby to support customers quickly and efficiently – wherever they are.

We have a passion for performance.



Volvo Trucks



Renault Trucks



Mack Trucks

UD Trucks

Volvo Buses

Volvo Construction Equipment

Volvo Penta

Volvo Financial Services

More space, more comfort, more work

The new and improved EW60E features a larger cab design for a comfortable and more productive operator environment. Improved ergonomics and a modern LCD display give you perfect control in all operations. Plenty of storage has been added for personal belongings.

Operator convenience

Increased storage space is available for operator comfort and convenience. A phone tray, two power sockets, cup holder and three other large storage areas makes the Volvo cab a more convenient working environment.



Operator visibility

All-round visibility is improved by thinner pillars, larger glazed area and enlarged wiper blade. The rear view camera secures a better view for perfect and safe control through the 7" color LCD display. This ensures there are no blind spots even in the most confined working areas.



Work in comfort

The comfortable and adjustable seat makes it easier for the operator to work hard all day and feel less tired by the end of it. The cab's air conditioning is 10% more efficient and in automatic mode, the temperature remains at a set level. Six adjustable vents allow for optimal airflow in the cab.



Ease of control

Control your machine with minimal effort in order to get more done in less time. The keypad groups all controls on the right hand side and the 7" color LCD screen displays all machine information for access to functions through its easy to use menus. Through the hot keys, the operator can directly access pre-set functions for added convenience. The new and improved proportional joystick provides better grip, fits your thumb perfectly and increases ease of control.





LARGER CAB

10% more space results in comfortable and relaxed operation, increasing production and reducing fatigue. The new cab design creates more space behind the seat, allowing the operator to move more freely within the space. The new generation Volvo Cab features more in cab room, increased glazed area and reduced noise levels.



BOOSTED PERFORMANCE

Do more in less time with increased combined digging efforts, a 5% increase in swing force, 4% in travel force and 10% in lifting capacity. The EW60E has been designed to tackle the most challenging job sites and contracts using the powerful Stage IIIB / Tier 4 final engine and adjustable hydraulic flow. Its well-balanced driveline delivers optimum performance whether working on the job site or on the move.

Power for performance

Climb quicker, swing smoother, dig harder and load faster with the EW60E. Improved traction, swing force and lifting capacity gets you results, fast. This versatile and powerful machine can be tailored for any job and is suitable for a wide range of applications.

Powerful Volvo Stage IIIB / Tier 4 final engine

Give your job site a boost and achieve fast results. Great power and effective cooling ensure optimized performance in any climate. For the ultimate combination of power and performance, the engine helps to push through challenging conditions.



Smooth operation

Smooth combined operation means you can make very accurate and precise movements. With responsive controls the machine does exactly what the operator intends for less fatigue and fluent movement.



Versatility

Perform on any job site, whether you're working in a confined space or major construction area. The machine's compact design, long arm, optional fixed boom and offset boom, longer dozer blade, auxiliary hydraulic and thumb pipings makes the machine suitable for a wide range of jobs and applications.



Wheeled performance

A top speed up to 30km/h and the four wheel drive allow you to go on and off-road for better mobility. Drive the machine easily between locations and access hard to reach job sites to save time and keep your machine in prime condition.



Profit in your business

The EW60E is designed and built to increase your profitability and keep you working for longer. To reduce your running costs it features excellent service access, convenient maintenance points and Volvo's auto engine shutdown feature. With better fuel efficiency than the previous machine series, this durable and reliable machine secures your costs and increases your uptime.

Low fuel consumption

The new Volvo engine and improved hydraulics together offer superior fuel efficiency. The standard auto idle feature helps to reduce your fuel consumption even further and increase your profits.



Auto engine shutdown

A unique offering from Volvo, the engine stops automatically after a preselected idle time, lowering fuel costs and noise. A stopped hour meter reduces maintenance costs and increases the resale value of the machine.



MATRIS and VCADS Pro

By working with your dealer and using Volvo MATRIS software you can analyse operator behaviour to improve efficiency, boost productivity and reduce your fuel and maintenance costs. Volvo also offers the VCADS Pro diagnostic system, making it easy to control your machine.



Durability and reliability

The EW60E is designed with the same high quality as all Volvo machines, including robust transmission system and axles, so you can be assured it's durable and reliable on your job site. You can depend on your machine to perform and work hard for peace of mind.





SERVICEABILITY

Keep your machine up and running with a number of features combined to increase machine availability and reduce downtime. Ground level service access, including new main control valve location, convenient greasing points, a tool box in the lower structure and an easy to clean cooling unit all reduce service time and maintenance costs. Check service intervals easily through the in-cab screen, which shows reminders when maintenance is needed.



ATTACHMENTS VERSATILITY

The machine's attachment can be easily changed to save time and costs. Its design, hydraulics, piping and in-cab switches combined with the Volvo attachments range allows the EW60E to take on a variety of tasks. Volvo attachments work in harmony with the machine to deliver maximum productivity.

One machine, many job sites

Volvo offers a wide range of durable attachments that are suitable for any job site, including utilities, building, agriculture, landscaping and forestry. Volvo attachments are an integrated part of the excavator for which they're intended – delivering maximum productivity and versatility.

Quick coupler

Both the mechanical and the hydraulic quick couplers allow attachments to be changed quickly and efficiently. Making it easier on site, the quick coupler picks different Volvo buckets and is the perfect match for the breakers and thumb.



Buckets

A complete range of buckets from general purpose reinforced buckets to ditching buckets, allow the machine to work on many job sites for a wide range of applications. The durable buckets can work in loose gravel, crushed rock, dirt and soil.



Breaker

Volvo's durable hydraulic breakers have been designed for ultimate compatibility with Volvo excavators. The wide range of breaker tools (or bits) has been built to break all kinds of materials and combines excellent performance with low noise and vibration levels.



Thumb

Designed to work with both Volvo direct fit buckets and quick coupler, the Volvo thumb makes many tasks possible, including piling, placing, loading, lifting and carrying.



A compact machine with big potential

BOOSTED PERFORMANCE

Do more in less time with combined digging efforts, a 10% improvement in traction, swing force and lifting capacity.

Smooth operation

Smooth combined operation means you can make very accurate and precise movements.

MATRIS and VCADS Pro

Volvo MATRIS analyses operator behaviour, improving efficiency and productivity. VCADS Pro helps to control your machine.

ATTACHMENTS VERSATILITY

The Volvo attachments range allows the machine to take on a variety of tasks for a wide range of jobs and applications.

Powerful Volvo Stage IIIB / Tier 4 final engine

For the ultimate combination of power and performance, the engine helps to push through challenging conditions.

Auto engine shutdown

The auto engine shutdown provides lower fuel costs, less noise, much lower maintenance costs and a greater resale value.



LARGER CAB

More space results in comfortable and relaxed operation, increasing production and reducing fatigue.

Ease of control

The keypad groups all controls on the right hand side and the LCD screen displays all machine information for access to functions.

Operator convenience

Increased storage space in the cab is available for operator comfort and convenience.

SERVICEABILITY

Ground level service access, new main control valve location, convenient greasing points and easy to clean cooling unit reduce service time.

Wheeled performance

A top speed up to 30km/h and the four wheel drive allow you to go on and off-road for better mobility.

CUSTOMER SUPPORT AGREEMENTS

Customer Support Agreements offer preventive maintenance, total repairs and a number of uptime services.



Adding value to your business

Being a Volvo customer means having a complete set of services at your fingertips. Volvo can offer you a long-term partnership, protect your revenue and provide a full range of customer solutions using high quality parts, delivered by passionate people. Volvo is committed to increasing the positive return on your investment and maximising uptime.

Complete Solutions

Volvo has the right solution for you. So why not let us provide all your needs throughout the whole life cycle of your machine? By listening

to your requirements, we can reduce your total cost of ownership and increase your revenue.



Genuine Volvo Parts

Our attention to detail is what makes us stand out. This proven concept acts as a solid investment in your machine's future. Parts are extensively tested and approved because every part is vital for uptime and performance. Only by using Genuine Volvo Parts, can you be sure that your machine retains the renowned Volvo quality.

Service Network

In order to respond to your needs faster, a Volvo expert is on their way to your job site from one of our Volvo facilities. With our extensive infrastructure of technicians, workshops and dealers, Volvo has a comprehensive network to fully support you using local knowledge and global experience.





CUSTOMER SUPPORT AGREEMENTS

The range of Customer Support Agreements offer preventive maintenance, total repairs and a number of uptime services. Volvo uses the latest technology to monitor machine operation and status, giving you advice to increase your profitability. By having a Customer Support Agreement you are in control of your service costs.

Volvo EW60E in detail

Engine

The new engine which provides excellent performance is equipped with a four-cylinder, vertical, electronic controlled high pressure fuel injectors, in-line turbo charger and water cooled diesel engine type. This engine fully meets the demands of the latest Tier 4f (Stage IIIB) emissions regulations.

Engine	Volvo	D2.6H
Max. power at	r/min	2 400
Net (ISO9249/SAEJ1349)	kW	45
	hp	61
Gross (ISO 14396/SAE J1995)	kW	47
	hp	64
Max. torque	Nm	222
at engine speed	r/min	1 500
No. of cylinders		4
Displacement	l	2.6
Bore	mm	87
Stroke	mm	110

Electrical system

Voltage	V	12
Batteries	V	1 x 12
Battery capacity	Ah	100
Alternator	V/Ah	12/90
Start motor	V - kW	12 - 2.5

Undercarriage

Drive train: One big variable axial-piston motor on the two-step Power Shift gear box gives power to front and rear axles.

Framework: All-welded robust torsion box frame.

Front axle: Robust excavator axle with automatic or operator controlled front axle oscillation lock.

Oscillating	± °	5
with mudguards	± °	5
Tire	type	12-16.5 12PR
Tractive force (net)	kN	29
Travel speed, on road	km/h	30
Travel speed, off road	km/h	20
Travel speed, creep	km/h	10
Min. turning radius	m	5,1
Travel speeds may depend on to local regulations		

Cab

Refrigerant of the type R134a is used when this machine is equipped with air conditioning. Contains fluorinated greenhouse gas R134a, Global Warming Potential 1.430 t CO₂-eq

Sound Level

Sound level in cab according to ISO 6396		
LpA	dB(A)	78
External sound level according to ISO 6395 and EU Noise Directive 2000/14/EC		
LwA	dB(A)	97

Hydraulic system

Open-center, negative hydraulic system providing accurate controllability. The following working modes are included in the system:
 Parking mode (P): Parking position for optimal safety.
 Travel mode (T): Engine speed is controlled by travel pedal stroke and mode selection switch for low fuel consumption and noise. Work equipment are not able to move at this mode for optimal safety.
 Working mode (W): Full working flow with adjustable engine rpm for normal working and best speed utilisation.

Main pump (Type: Variable-displacement pump)		
Max. flow	l/min	2 x 60
Pilot pump (Type: Gear pump)		
Max. flow	l/min	1 x 21,4
Swing + steering pump (Type: Low noise gear pump)		
Max. flow	l/min	1 x 38,9
Relief valve setting pressure		
Implement	MPa	23
Travel system	MPa	23
Slew system	MPa	19
Pilot system	MPa	3,1

Hydraulic Cylinders

Boom		1
Bore x Stroke	ø x mm	110 x 707
Arm		1
Bore x Stroke	ø x mm	90 x 813
Bucket		1
Bore x Stroke	ø x mm	80 x 660
Dozer blade		1
Bore x Stroke	ø x mm	105 x 230
Boom swing		2
Bore x Stroke	ø x mm	90 x 570

Brake system

Service brakes: servo-hydraulically manoeuvred self-adjusting wet multidiscs with two separate brake circuits.

Parking brake: negative wet disc in gear housing, spring applied and pressure released.

Digging brake: service brake with mechanical lock system.

Security system: The 2-circuit travel brakes are supplied with two accumulators in the event of failure in the service brake system. (Option only)

Swing system

No need for gear oil replacement: The lubricating system uses hydraulic operation oil for the reduction gear, eliminating the need for gear oil replacement.

Built-in parking brake: Parking brake can be built into the hydraulic motor, enabling safer parking on an incline.

Shockless function: Shockless relief is standard equipment to enable smooth traversing.

Max. slew speed	r/min	10
Max. slew torque	kNm	11,6

Total Machine Weights

Machine with 2.9m boom, 1.6m arm, 0.142m³ bucket, standard counterweight, dozer blade, without quick coupler and 75kg operator weight

With dozer blade	kg	5 880
------------------	----	-------

Service Refill

Fuel tank	l	105
Hydraulic system, total	l	120
Hydraulic tank	l	76
Engine oil	l	11
Engine coolant	l	10
Transmission	l	1,7
Axle differential:		
Front axle	l	6,3
Rear axle	l	8

Specifications

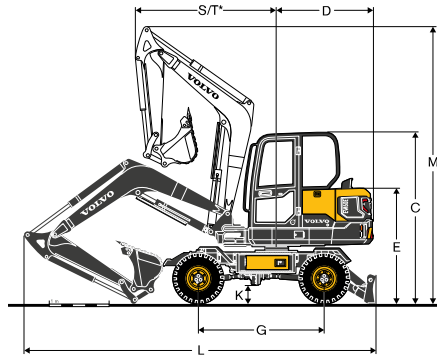
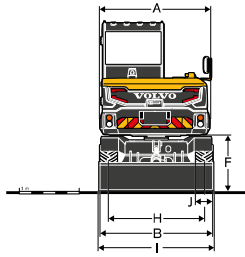

DIMENSIONS		EW60E
Boom	m	2.9
Arm	m	1.6
A Overall width of upper structure	mm	1 845
B Overall width	mm	1 930
C Overall height of cab	mm	2 855
D Tail swing radius	mm	1 650
E Overall height of engine hood	mm	1 901
F Counterweight clearance	mm	960
G Wheel base	mm	2 100
H Tread width	mm	1 595
I Dozerblade width	mm	1 930
J Tire width	mm	305
K Min. ground clearance	mm	295
L Overall length	mm	5 869
M Overall height of boom raise	mm	4 599
S Front swing radius	mm	2 352
T* Front swing radius(Max. offset)	mm	1 386
O Boom swing distance	mm	756
P Boom swing distance	mm	863
Q Boom swing angle	°	70
R Boom swing angle	°	60

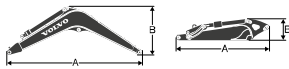
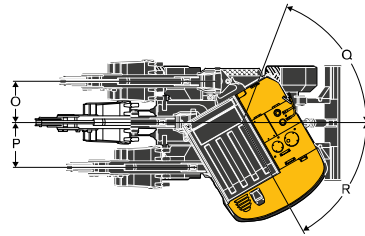

DIMENSIONS		Boom	Arm
	m	2.9	1.6
A Length	mm	3 008	2 102
B Height	mm	1 159	488
Width	mm	336	300
Weight	kg	349	206

Boom * Includes cylinder, piping and pin, excludes boom cyl. Pin
 Arm * Includes cylinder, linkage and pin

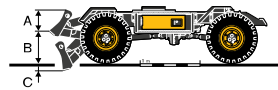

DIMENSIONS		Dozer blade
A Height	mm	465
Width	mm	1 930
B Lifting height	mm	440
C Digging depth	mm	140

Specifications

WORKING RANGES

Description	Unit	
Boom	m	2.9
Arm	m	1.6
A Max. digging reach	mm	6 090
B Max. digging reach on ground	mm	5 880
C Max. digging depth	mm	3 360
D Max. digging depth (l=2 440 mm level)	mm	2 990
E Max. vertical wall digging depth	mm	2 730
F Max. cutting height	mm	6 070
G Max. dumping height	mm	4 380
H Min. front swing radius	mm	2 360

DIGGING FORCES WITH DIRECT FIT BUCKET

Breakout force (bucket)	SAE J1179	kN	39.5
	ISO 6015	kN	43.4
Tearout force (arm)	SAE J1179	kN	27.2
	ISO 6015	kN	27.6
Rotation angle, bucket		°	175

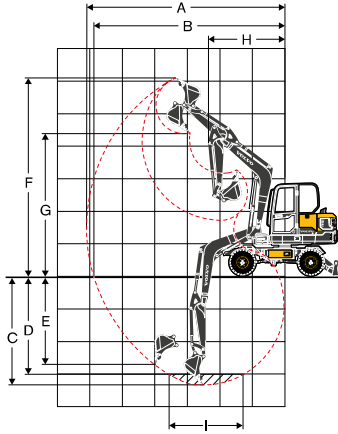

LIFTING CAPACITY EW60E

Lifting capacity at the arm end without bucket.

For lifting capacity including bucket, simply subtract actual weight of the direct fit bucket or the bucket with quick coupler from the following values.

	Lifting hook related to ground level	kg	1.0 m		2.0 m		3.0 m		4.0 m		5.0 m		Max. reach		
			Along UC	Across UC	Along UC	Across UC	Along UC	Across UC	Along UC	Across UC	Along UC	Across UC	mm		
			Boom: 2.9 m Arm: 1.6 m GP Shoe: Wheel CWT: 350 kg Machine: Front direction Dozer blade: Down	5.0 m	kg							1 520	1 170		
	4.0 m	kg							1 520	1 100			1 270	980	4 421
	3.0 m	kg							1 610	1 150			1 190	810	4 947
	2.0 m	kg					2 540	1 690	1 840	1 100	1 530	780	1 200	740	5 190
	1.0 m	kg					3 030	1 580	2 040	1 050	1 570	770	1 280	720	5 197
	0.0 m	kg			2 110	2 110	3 040	1 540	2 070	1 030			1 470	760	4 969
	-1.0 m	kg	3 000	3 000	4 060	3 020	2 650	1 540	1 800	1 020			1 420	890	4 464
	-2.0 m	kg			2 450	2 450	1 680	1 590					1 180	1 180	3 530
Boom: 2.9 m Arm: 1.6 m GP Shoe: Wheel CWT: 350 kg Machine: Front direction Dozer blade: Up	5.0 m	kg											1 520	1 380	3 449
	4.0 m	kg							1 520	1 100			1 270	920	4 421
	3.0 m	kg							1 610	1 080			1 190	760	4 947
	2.0 m	kg					2 540	1 580	1 840	1 030	1 410	740	1 200	690	5 190
	1.0 m	kg					3 030	1 480	1 950	990	1 390	720	1 280	680	5 197
	0.0 m	kg			2 110	2 110	3 040	1 440	1 920	960			1 390	710	4 969
	-1.0 m	kg	3 000	3 000	4 060	2 770	2 650	1 440	1 800	960			1 420	830	4 464
	-2.0 m	kg			2 450	2 450	1 680	1 480					1 180	1 180	3 530
Boom: 2.9 m Arm: 1.6 m GP Shoe: Wheel CWT: 350 kg Machine: Rear direction Dozer blade: Down	5.0 m	kg											1 520	1 470	3 449
	4.0 m	kg							1 520	1 170			1 270	980	4 421
	3.0 m	kg							1 610	1 150			1 190	810	4 947
	2.0 m	kg					2 540	1 690	1 840	1 100	1 530	780	1 200	740	5 190
	1.0 m	kg					3 030	1 580	2 040	1 050	1 570	770	1 280	720	5 197
	0.0 m	kg			2 110	2 110	3 040	1 540	2 070	1 030			1 470	760	4 969
	-1.0 m	kg	3 000	3 000	4 060	3 020	2 650	1 540	1 800	1 020			1 420	890	4 464
	-2.0 m	kg			2 450	2 450	1 680	1 590					1 180	1 180	3 530
Boom: 2.9 m Arm: 1.6 m GP Shoe: Wheel CWT: 350 kg Machine: Rear direction Dozer blade: Up	5.0 m	kg											1 370	1 380	3 449
	4.0 m	kg							1 100	1 100			920	920	4 421
	3.0 m	kg							1 080	1 080			760	760	4 947
	2.0 m	kg					1 570	1 580	1 030	1 030	740	740	690	690	5 190
	1.0 m	kg					1 470	1 480	990	990	720	720	680	680	5 197
	0.0 m	kg			2 110	2 110	1 430	1 440	960	960			720	710	4 969
	-1.0 m	kg	3 000	3 000	2 740	2 770	1 430	1 440	960	960			830	830	4 464
	-2.0 m	kg			2 450	2 450	1 470	1 480					1 180	1 180	3 530

Notes: 1. The above loads are in compliance with SAE J1097 and ISO 10567 Hydraulic Excavator Lifting Capacity Standards.

2. Rated loads do not exceed 87% of hydraulic lifting capacity or 75% of tipping load.

3. Rated loads marked with an asterisk (*) are limited by hydraulic capacity rather than tipping load.

Equipment

STANDARD EQUIPMENT

Engine
Low-emission Volvo T4 diesel engine
Standard cooling system
Two-stage air filter
Fuel filter and water separator
Alternator, 90 A
Electric / Electronic control system
Safe engine start function
Automatic idling system
Halogen working lights;
Cab-mounted 1 (Front), Boom-mounted 1(LH)
Battery, 12 V / 100 Ah
Start motor, 12 V / 2.5 kW
Monitor and keypad
Master electrical disconnect switch
Travel alarm
Frame
Rearview mirror
350kg counterweight
Under cover
Dozer blade
Undercarriage
Tyre: 12.00-16.5 12PR
Hydraulic system
Automatic two speed travel motors
Cylinder cushioning
Hydraulic fluid mineral 46
Travel motor (30km/h)
Cab and interior
Cab
Fabric operator seat with suspension
Seat belt, 2 inch retractable
Control joystick
Radio with MP3/AUX
Master key
Hour meter (non analog)
Digging Equipment
Boom: 2.9m, Arm: 1.6m
Linkage
Service
Tool kit-daily maintenance

OPTIONAL EQUIPMENT

Engine
Water separator (With heater)
Engine auto shut down
Electric / Electronic control system
Fuel filler pump: 35 l/min, with automatic shut-off
Halogen extra working lights;
Cab-mounted 1 (Rear)
Boom-mounted 1 (RH)
Caretrack
Air compressor
Microphone
Rotating warning beacon
Electric pilot control change
Rearview Camera
Electric dozer blade switch on joystick
Hydraulic system
Hydraulic piping:
Breaker & shear
Slope & rotator
Grapple
Quick coupler
Hose rupture valve for boom, arm
Overload warning device
Hydraulic oil, ISO VG 32, 68
Hydraulic oil, biodegradable 46
Hydraulic oil, longlife oil 32, 46, 68
Travel motor (20km/h)
Cab and interior
Heater and air-conditioner
Fabric operator seat with suspension with heater
PVC operator seat with suspension
Control joystick, X3 proportional
Radio with MP3/AUX/Bluetooth
Mechanical hour meter
Cab mounted FOG (Falling Object Guard)
FOPS (Falling Object Protection Structure)
Sun screen, front/roof
Safety net
Service
Tool kit, full scale
Spare parts

SELECTION OF VOLVO OPTIONAL EQUIPMENT

Electric dozer blade switch on joystick



Rear view camera



Auxiliary hydraulic piping (X3)



LED Light



Heated seat



Fixed boom



Not all products are available in all markets. Under our policy of continuous improvement, we reserve the right to change specifications and design without prior notice. The illustrations do not necessarily show the standard version of the machine.

