

Genie®

A TEREX COMPANY



OPERATOR HANDBOOK

Code 57.0005.9200 - Rev.0 12/2005

Handler with telescopic boom *GTH-5519*

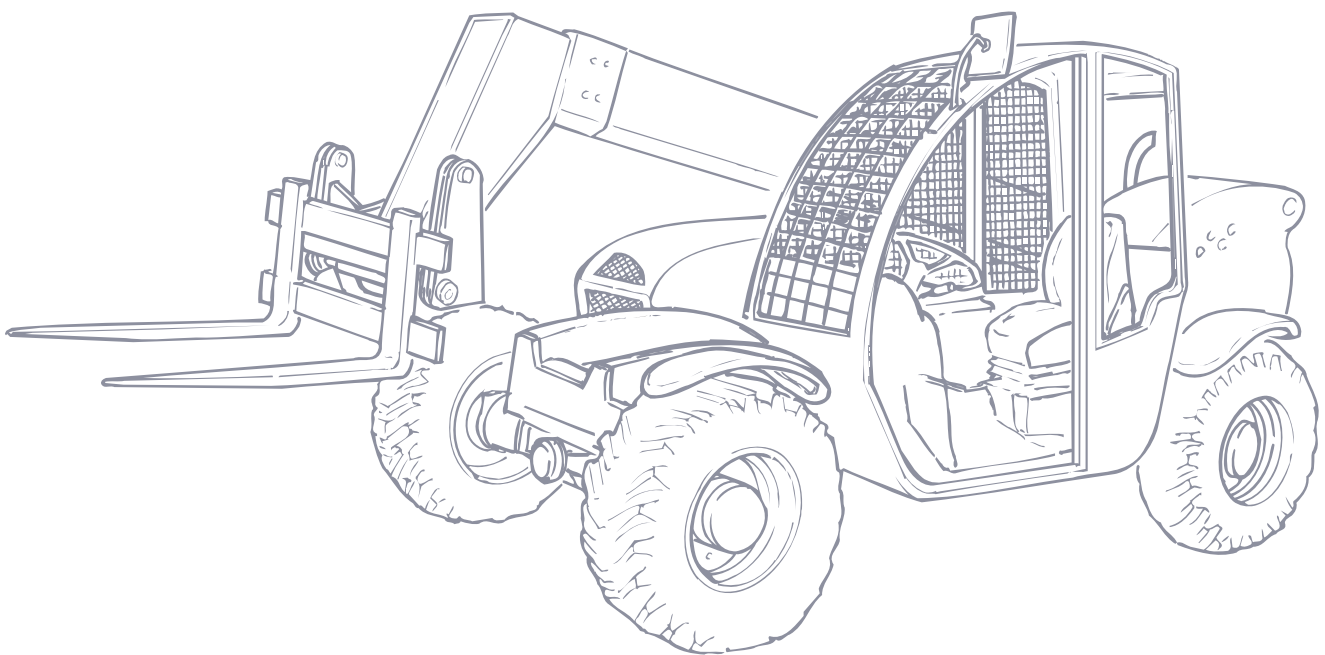

From serial n. **10242**
To serial n. **18818**

English
Edition



CAUTION: THOROUGHLY READ AND UNDERSTAND THIS HANDBOOK BEFORE OPERATING THE MACHINE
CAUTION: KEEP THIS HANDBOOK IN THE MACHINE AT ALL TIMES

Genie®

A TEREX COMPANY

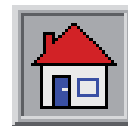

TECHNICAL SERVICES

Genie Scandinavia Phone +46 31 575100 Fax +46 31 579020	Genie Mexico City Phone +52 55 5666 5242 Fax +52 55 5666 3241	Genie Malaysia Phone +65 98 480 775 Fax +65 67 533 544
Genie France Phone +33 (0)2 37 26 09 99 Fax +33 (0)2 37 26 09 98	Genie North America Phone 425.881.1800 Toll Free USA and Canada 800.536.1800 Fax 425.883.3475	Genie Japan Phone +81 3 3453 6082 Fax +81 3 3453 6083
Genie Iberica Phone +34 93 579 5042 Fax +34 93 579 5059	Genie Australia Pty Ltd. Phone +61 7 3375 1660 Fax +61 7 3375 1002	Genie Korea Phone +82 25 587 267 Fax +82 25 583 910
Genie Germany Phone +49 (0)4202 88520 Fax +49 (0)4202 8852-20	Genie China Phone +86 21 53852570 Fax +86 21 53852569	Genie Brasil Phone +55 11 41 665 755 Fax +55 11 41 665 754
Genie U.K. Phone +44 (0)1476 584333 Fax +44 (0)1476 584334		Genie Holland Phone +31 183 581 102 Fax +31 183 581 566

Operator Handbook 57.0005.9200 - GTH-5519

All rights reserved. No part of this publication may be reproduced, stored in a retrieval system or transmitted in any form or by any means without prior written permission from TEREXLIFT srl.

In pursuing a policy of constant quality improvement, TEREXLIFT srl reserves the right to make changes at any time and without undertaking to give prior notice; therefore, also this publication may be subject to modifications.

Some photos or drawings have been used to illustrate a specific function; as a result, they may not refer to the machine treated in this manual.

© Copyright 2006 TEREXLIFT srl - All rights reserved.

Produced by:





LIST OF THE REVISED PAGES

Revision No.	Revision date	Revised pages	Notes	Issued by
1	06/2004	B-7, C-20, D-1, D-3, D-7, D-27 D-12 oil level	Revised pages Added pages: engine	
2				
3				
4				
5				
6				
7				
8				
9				
10				
11				
12				
13				
14				
15				
16				
17				
18				
19				
20				
21				
22				
23				
24				
25				
26				
27				
28				
29				
30				
31				
32				
33				
34				
35				
36				
37				
38				



LIST OF THE REVISED PAGES

Revision No.	date	Revised pages	Notes	Issued by
1				
2				
3				
4				
5				
6				
7				
8				
9				
10				
11				
12				
13				
14				
15				
16				
17				
18				
19				
20				
21				
22				
23				
24				
25				
26				
27				
28				
29				
30				
31				
32				
33				
34				
35				
36				
37				
38				
39				
40				

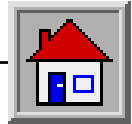

INTRODUCTION

■ INTRODUCTION

This handbook provides information for a safe and proper operation and maintenance of the machine.

STRICTLY COMPLY WITH THE INSTRUCTIONS GIVEN IN THIS HANDBOOK! READ AND UNDERSTAND THIS HANDBOOK BEFORE STARTING, USING AND CARRYING OUT ANY OPERATION WITH AND ON THE MACHINE.

The handbook is divided into seven sections:

- Sect. **A** GENERAL INFORMATION
- Sect. **B** SAFETY
- Sect. **C** OPERATING INSTRUCTIONS
- Sect. **D** MAINTENANCE
- Sect. **E** TROUBLESHOOTING
- Sect. **F** OPTIONAL ATTACHMENTS
- Sect. **G** TABLES AND ENCLOSURES

Section **A** contains general concepts that are decisive for the knowledge of the main parts of the machine. It also contains all necessary data for a correct identification of the machine, the technical features of the machine, etc.

Section **B** is especially addressed to the personnel, who shall operate, repair and service the machine, and, in case of companies with a wide fleet of machines, to the safety responsible.

It describes the essential compulsory qualities of the personnel in charge and other important information for the safety of persons and things.

Section **C** is mainly addressed to the operators who operate the machine. This section illustrates all control devices.

Additionally, it contains the main use instructions -i.e. engine starting, machine parking, machine storing.

Section **D** is addressed to the maintenance responsible and the servicemen.

The section describes the maintenance schedule and the relevant intervals.

Section **E** deals with the failure diagnostics.

Section **F** makes a list of the main interchangeable attachments that can be coupled to the machine: dimensions, weight, application field and limits of use.

Section **G** contains tables and various enclosed documents like load charts, wiring diagrams, hydraulic schemes, torque wrench setting table, etc.

Sections are subdivided into chapters and paragraphs that are numbered progressively.

The quickest way to look for an information is the reference to the general index or the titles of the single chapters and paragraphs that represent keys for an easy consultation.

Take care of this handbook and keep it in an accessible place within the machine, even after its reading, so that it will always be within reach if in doubt.

If you are unsure about anything, please address to GENIE Assistance Service or to your agent/dealer: addresses, phone and fax numbers are printed in the cover and in the title-page of this manual.

IMPORTANT

Any difference between the contents of this manual and the real functional character of the machine can be attributed to either a machine manufactured before the issue of this manual or to a manual going to be updated after some changed effected on the machine.

Always contact GENIE Assistance Service for any updated version of this manual and any additional information.

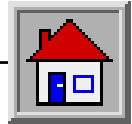

INTRODUCTION

■ **SYMBOLS**

When using the machine, operators could have to face some situations requiring special care and particular knowledge.

When these situations involve the safety of operators or bystanders, the machine efficiency and proper utilisation, this handbook stresses these specific instructions by means of **SPECIAL SYMBOLS**.

There are six special (or safety) symbols in this manual, always combined with keywords that class the situations according to their danger degree.

The symbols are always followed by a text explaining the situation taken into account, the attention to be paid to such situation, the method and the behaviour to be adopted. When necessary, it stresses prohibitions or supplies instructions to prevent dangers.

Sometimes, it can be followed by illustrations.

We list below the special (or safety) symbols according to the relative seriousness of the hazard situation:



Draws the attention to situations that involve your own as well as the others' safety and that can result in serious or lethal injury.



Draws the attention to situations that involve your own as well as the others' safety and that can result in serious injury or lethal injury.



Draws the attention either to situations that involve your own as well as the others' safety and that can result in minor or moderate injury or to situations that involve the machine efficiency.



Draws the attention to situations that involve the machine efficiency.



Draws the attention to important technical information or practical advice that allows for a safer and more efficient use of the machine.



Draws the attention to important environment-related information.

WHEN READING THIS MANUAL, PAY THE GREATEST ATTENTION TO THESE SPECIAL SYMBOLS AND THE EXPLANATION OF THE SITUATIONS THEY EMPHASIZE.

The manual in electronic format also contains the following symbol:

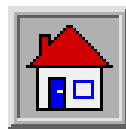

which enables the user to return to the table of contents

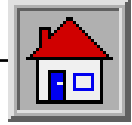

GENERAL INDEX

GENERAL INDEX

GENERAL INFORMATION	Sect.	A
SAFETY	Sect.	B
OPERATING INSTRUCTIONS	Sect.	C
MAINTENANCE	Sect.	D
TROUBLESHOOTING	Sect.	E
OPTIONAL ATTACHMENTS	Sect.	F
TABLES AND DOCUMENTS ENCLOSED	Sect.	G

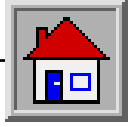

Intentionally blank page

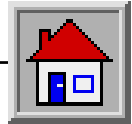

GENERAL INFORMATION

Section A

GENERAL INFORMATION

TABLE OF CONTENTS

A-1	CONVENTIONAL REFERENCES	A-2
A-1.1	Machine position	A-2
A-1.2	Labels and warning plates applied on the machine	A-3
A-1.2.1	Position	A-3
A-1.3	Explanation of the different symbols used on the machine	A-6
A-2	MACHINE IDENTIFICATION	A-8
A-2.1	Machine model and type	A-8
A-2.2	Manufacturer	A-8
A-2.3	Machine identification plates	A-8
A-2.4	Chassis serial number	A-9
A-2.5	Identification plates of the main parts	A-9
A-3	ALLOWED USE	A-10
A-3.1	Allowed use	A-10
A-3.2	Improper use	A-10
A-3.3	Residual hazards	A-10
A-3.4	Applicable standards	A-11
A-3.5	Safety devices	A-12
A-4	GENERAL DESCRIPTION	A-13
A-4.1	List of the main components	A-13
A-4.2	Description of the main components	A-14
A-4.3	Optional accessories	A-14
A-4.4	Kits supplied on request	A-14
A-5	TECHNICAL DATA AND PERFORMANCE	A-15
A-5.1	Main dimensions	A-15
A-5.2	Restrictions of use	A-15
A-5.3	Weight	A-15
A-5.4	Speed	A-15
A-5.5	Payload and reach	A-16
A-5.6	Forks	A-16
A-5.7	Diesel engine	A-16
A-5.8	Electrical system	A-16
A-6	LIFETIME	A-17
A-7	ITEMS SUPPLIED	A-17
A-7.1	Literature supplied	A-17

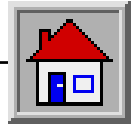

GENERAL INFORMATION

■ A-1 CONVENTIONAL REFERENCES

■ A-1.1 MACHINE POSITION

Conventionally the machine should be considered positioned as shown in the figure.

This convention is necessary to make any reference of this handbook to different machine parts (front, rear, etc.) clear and unmistakable.

Any exception to this rule will always be specified.

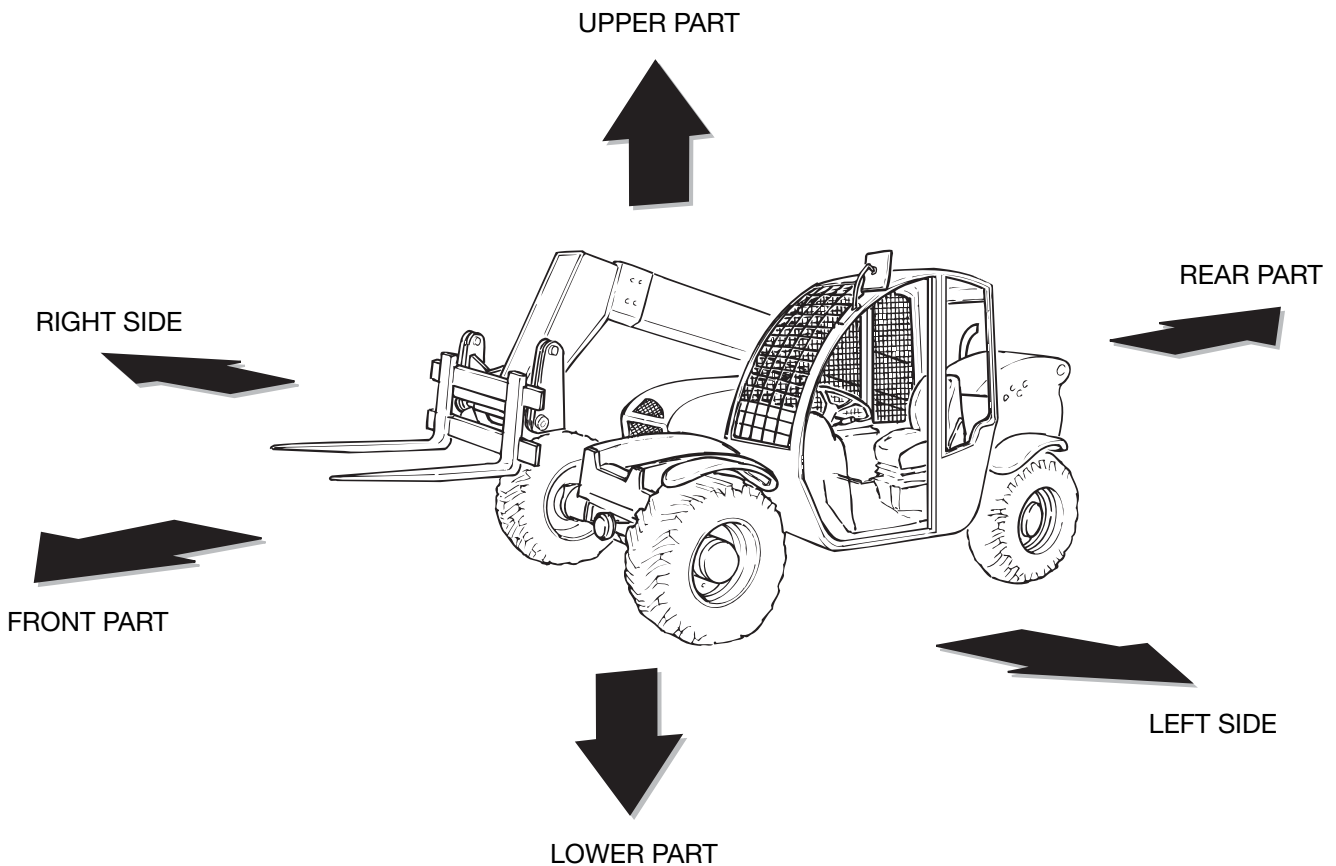

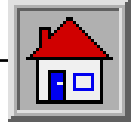

GENERAL INFORMATION

■ A-1.2 LABELS AND WARNING PLATES APPLIED ON THE MACHINE

This paragraph lists the labels and warning plates normally applied on standard machines or on special attachments coupled to the machine.

IMPORTANT

The familiarisation with these labels is never a waste of time.

Make sure they are easy to read. For this purpose, clean them or replace those that become unreadable (either graphic or text).

To clean labels, use of a soft cloth, water and soap. Never use solvents, petrol, etc.

When a label is applied on a part to be replaced, make sure that the replaced part is already labelled as required or apply a new label.

■ A-1.2.1 Position

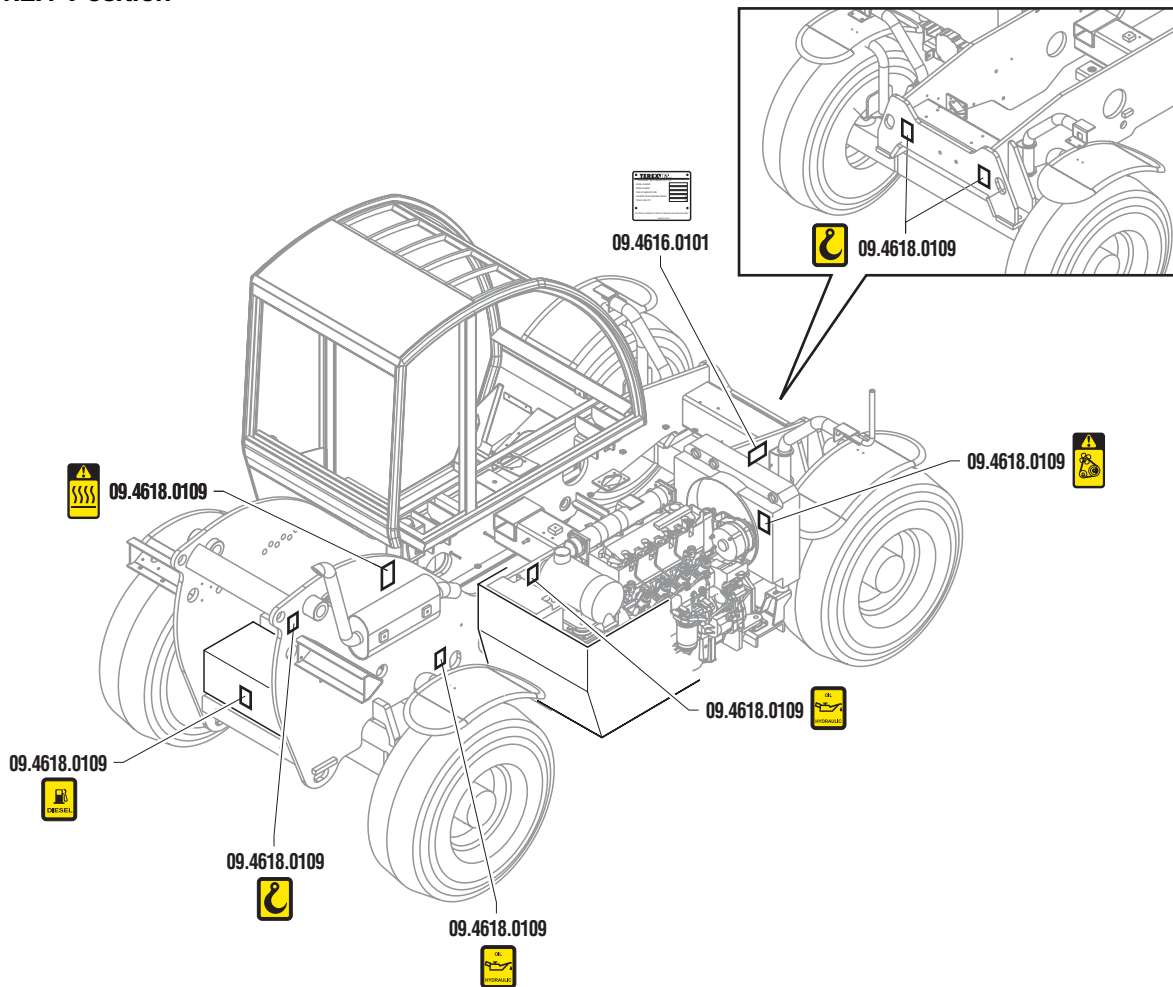

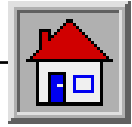

GENERAL INFORMATION

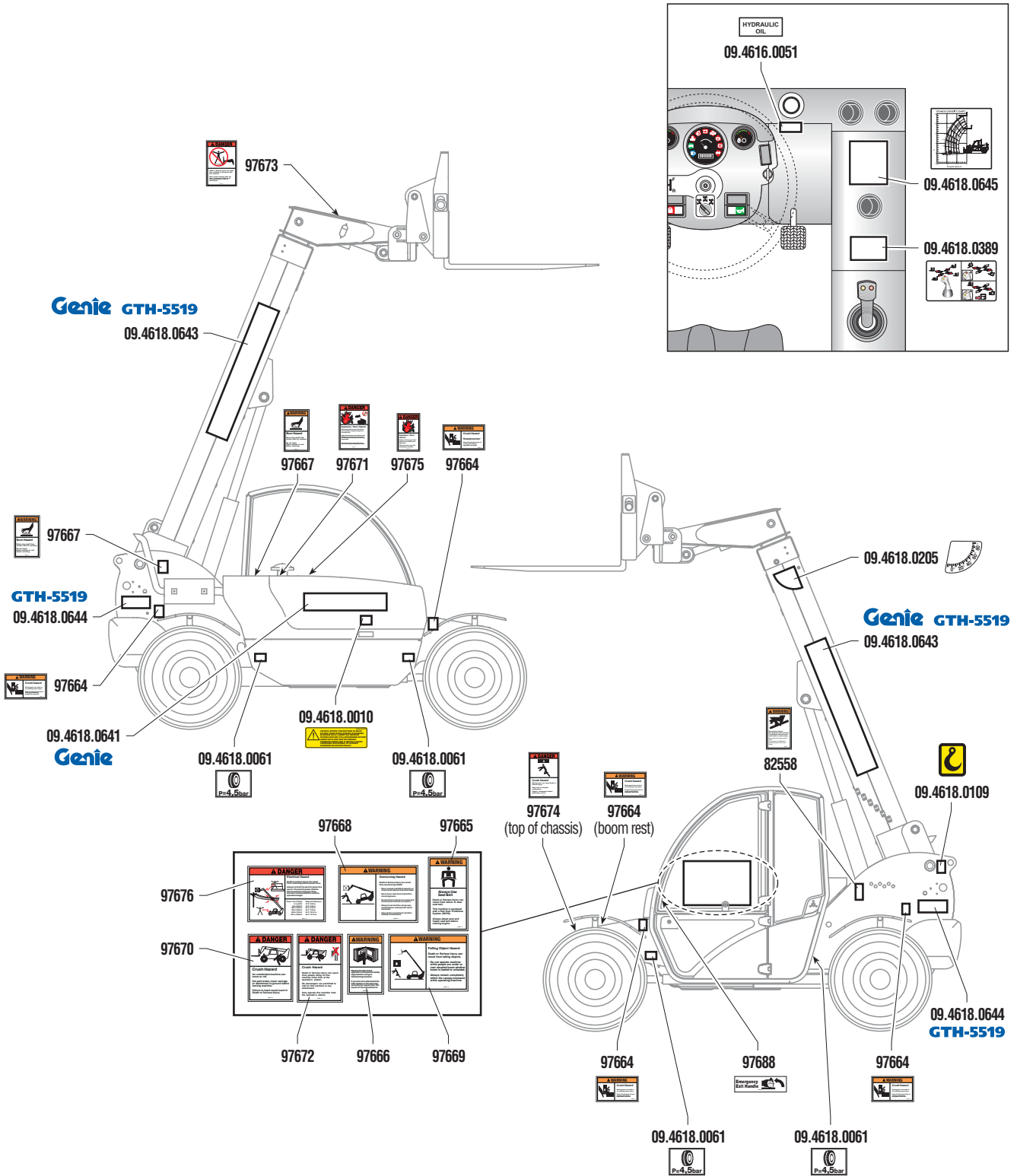

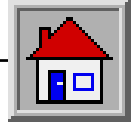

GENERAL INFORMATION

Code	Description
82558	Fluid at pressure
97664	Risk of crushing hands
97665	Safety belts
97666	Read the user's manual
97667	Risk of burns and scalds
97668	Risk of overturning
97669	Risk due to falling objects
97670	Risk of crushing
97671	Risk of explosion / burns
97672	Risk of crushing
97673	Prohibition to lift people
97674	Risk of crushing
97675	Risk of explosion / burns
97676	Electrical hazard
97688	Emergency exit handle
09.4616.0051	Hydraulic oil
09.4616.0101	Machine data plate
09.4618.0010	Prohibition to open with the engine running
09.4618.0061	Tyre inflation pressure
09.4618.0109	Sticker with various warnings
09.4618.0205	Boom tilting degree
09.4618.0389	Control lever controls
09.4618.0641	Sticker: "Genie"
09.4618.0643	Sticker: "Genie GTH-5519"
09.4618.0644	Sticker: "GTH-5519"
09.4618.0645	Load chart

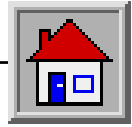

GENERAL INFORMATION

■ A-1.3 EXPLANATION OF THE DIFFERENT SYMBOLS USED ON THE MACHINE

This paragraph illustrates those symbols that are normally applied on the main control devices and instruments of a standard machine, and those that can be applied on accessories or special attachments. They are mainly (ISO) standardised symbols that are now part of the common life. But we consider useful to explain them once again.

IMPORTANT



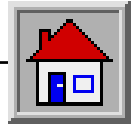

Spend the necessary time to become familiar with these symbols and to learn their meaning.

Symbol	Description
	Hazard warning lights
	Windscreen wiper
	Windscreen washer
	Cab ventilation fan
	Fuel gauge
	Hydraulic oil temperature
	Position lights
	High beam
	Turn signals
	Parking brake
	Battery charge

Symbol	Description
	Steering mode switch
	Engine oil pressure
	Boom up
	Boom down
	Boom out
	Boom in
	Attachment locked
	Attachment unlocked
	Fork pitching forward
	Fork pitching back
	Oil filter clogged
	Air filter clogged
	Glow plug preheating



GENERAL INFORMATION

Symbol	Description	Symbol	Description
	Front (optional) work light		
	Road/jobsite selector switch		
	Lifting point		
	Fuel plug		
	Engine oil filler		

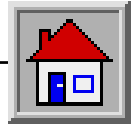

GENERAL INFORMATION

A-2 MACHINE IDENTIFICATION

IMPORTANT

Check that the operator handbook refers to the delivered machine.
When asking for information or technical assistance, always specify model, type and serial number of the machine.

A-2.1 MACHINE MODEL AND TYPE

Handler with telescopic boom:

model **GTH-5519**

A-2.2 MANUFACTURER

TEREXLIFT srl

Zona Industriale (Ind. Estate) - I-06019 UMBERTIDE (PG) - ITALY

Enrolled in the register of companies at the Court of Perugia under no. 4823

C.C.I.A.A. n° 102886

Fiscal Code/V.A.T. no. 00249210543

A-2.3 MACHINE IDENTIFICATION PLATES

A Machine data plate.

At the front, on the right side of the chassis.

The identification plate contains the main identification data of the machine like model, serial number and year of manufacture.

TEREXLIFT s.r.l.	
<small>Zona Industriale - 06019 - Umbertide (PG) - Italy</small>	
MODEL NUMBER	<input type="text"/>
SERIAL NUMBER	<input type="text"/>
YEAR OF MANUFACTURE	<input type="text"/>
UNLADEN TRUCK MAXIMUM WEIGHT	<input type="text"/> Lb
TRUCK CAPACITY	<input type="text"/> Lb
<small>THIS TRUCK IS COMPLIANT TO PART III OF ASME B56.6 - 2002 WHERE APPLICABLE MADE IN ITALY</small>	



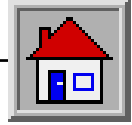

GENERAL INFORMATION

■ A-2.4 CHASSIS SERIAL NUMBER

The chassis serial number **D** is punched on the front left part of the chassis side member.



■ A-2.5 IDENTIFICATION PLATES OF THE MAIN PARTS

The plates of the main components, not directly manufactured by **TEREXLIFT srl** (for instance, engines, pumps, etc.), are located where originally applied by the manufacturers.

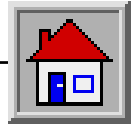

GENERAL INFORMATION

A-3 ALLOWED USE

A-3.1 ALLOWED USE

The handlers have been designed and manufactured for lifting, handling and transporting agricultural or industrial products by means of specific attachments (see section F) manufactured by TEREXLIFT srl.

Any other use is considered contrary to that established and, therefore, improper.

The compliance with and the strict respect of the operation, maintenance and repair conditions, indicated by the Manufacturer, represent an essential part of the allowed use.

The handler must be used and serviced only by operators knowing its characteristics and the safety procedures in depth.

It is also essential to comply with the safety at work legislation, the precautions concerning safety and industrial medicine as well as the local and national road traffic regulations.

ATTENTION

Effecting changes or carrying out interventions on the machine other than those of routine maintenance is expressly forbidden. Any modification of the machine not carried out by GENIE or an authorised assistance centre involves the automatic invalidation of the conformity of the machine to the Directive 98/37/EC.

A-3.2 IMPROPER USE

Improper use means a utilisation of the handler following working criteria that do not comply with the instructions of this manual, and that, in general, may result in risks for both operators and bystanders.



DANGER

We list below some of the most frequent and hazardous situations of improper use:

- **Carrying passengers on the machine**
- **Not strictly complying with the operation and maintenance instructions of this handbook**
- **Working beyond the handler working limits**
- **Working on unstable edges of ditches**
- **Driving crosswise on slopes or hills**
- **Working during a storm**
- **Working on steep slopes**
- **Using attachments other than those recommended**
- **Using attachments not approved or directly manufactured by Terexlift**
- **Working in potentially explosive areas**
- **Working in confined and non-ventilated environments.**

A-3.3 RESIDUAL HAZARDS

Although the machine has been designed and manufactured according to the latest technology and all expected hazards have been eliminated, some operations performed by the machine operator can result in potentially hazardous situations. Among them:

- Hazards deriving from a too high work or transfer speed in relation to the load handled or the ground condition of the jobsite.
- Hazards deriving from work procedures adopted during the check or replacement of a block valve (residual pressure - uncontrolled movements).
- Hazards deriving from work procedures adopted while disassembling parts of the machine -e.g. the cylinders, without supporting mobile parts suitably (risk of uncontrolled fall of the mobile part).
- Hazard deriving from an accidental overturning of the machine in the event the operator has not fastened the safety belts.

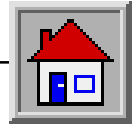

GENERAL INFORMATION

■ **A-3.4 APPLICABLE STANDARDS**

For the operator’s safety, the following standards were obeyed during the risk assessment of the handler fitted with telescopic boom:

Directive	Title
98/37/CE	Machinery Directive
89/336/CEE	Electromagnetic compatibility
2000/14/CE	Environment Acoustic Emissions

Standard	Title
EN 1459:1988	Harmonised standard. Safety of industrial trucks - Self- propelled variable reach trucks.
EN 281:1988	Self-propelled industrial trucks sit- down rider-controlled. Rules for the construction and layout of pedals.
EN 1175-2:1998	Electrical requirements - General requirements of internal combustion engine powered trucks
prEN ISO 13564:1996	Test method for measuring visibility from self-propelled trucks.
ISO 2330:1995	Fork-lift trucks - Fork arms - Technical characteristics and testing.
ISO/DIS 3287	Powered industrial trucks. Pictorial signs. Control symbols.
ISO 3449:1992	Earth-moving machinery - Falling-object protective structures - Laboratory tests and performance requirements.
EN 13510: 2002	Earth-moving machinery - Roll-over protective structures - Laboratory tests and performance requirements.
ISO 3776:1989	Tractors for agriculture - Seat belt anchorages.
ISO 3795:1989	Road vehicles, tractors and machinery for agriculture and forestry - Determination of burning behaviour of interior materials.
ISO 5053:1987	Powered industrial trucks - Terminology.
ISO 6292:1996	Powered industrial trucks and tractors - Brake performance and component strength.
EN 13059:2002	Safety of industrial trucks - Test methods for measuring vibration

- EN 50081-1: 1997 Electromagnetic compatibility – Generic requirements on emissions - Part 1
- EN 50082-1: 1997 Electromagnetic compatibility – Generic requirements on immunity - Part 1
- EN 60204-1:1998 Safety of machinery - Electrical equipment of machines - Part 1
- ANSI/ASME B56.6-2002 part III where applicable.

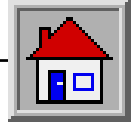

GENERAL INFORMATION

■ **A-3.5 SAFETY DEVICES**

- The machine is equipped with a negative brake on the front axle which engages automatically when the engine stops. When this brake is disengaged, the engine start-up is inhibited.

• **Block valves fitted to all cylinders:**

- A** Block valve on attachment coupling cylinder
- B** Block valve on lifting cylinder
- C** Block valve on balance cylinder
- D** Block valve on boom extension cylinder
- E** Block valve on attachment pitching cylinder

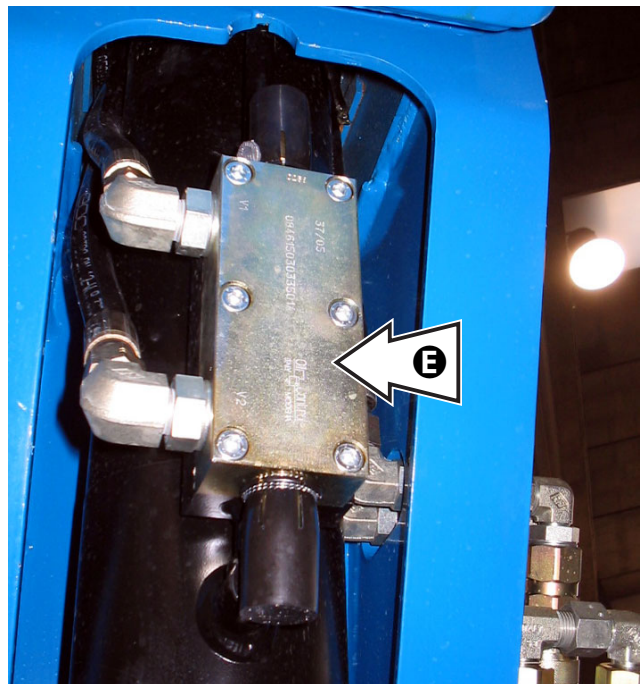
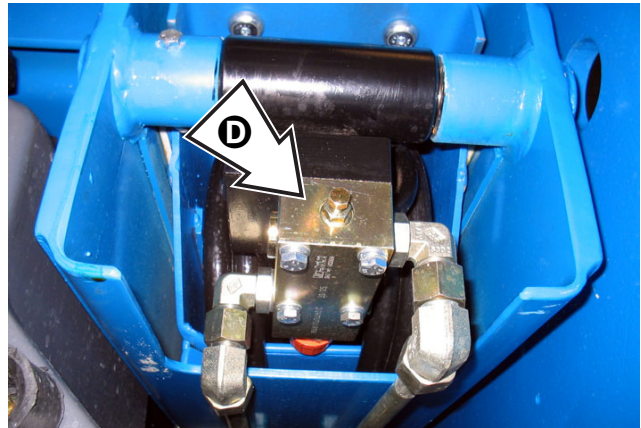
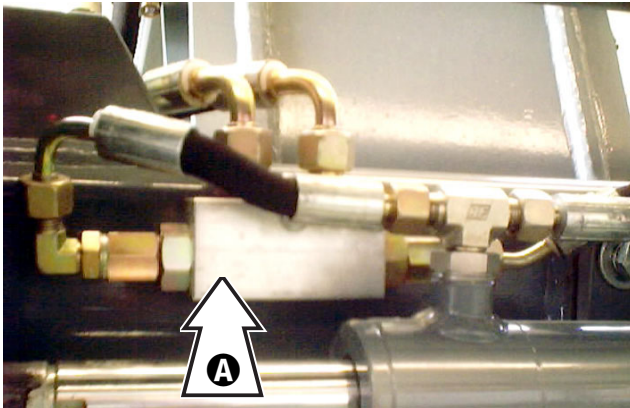
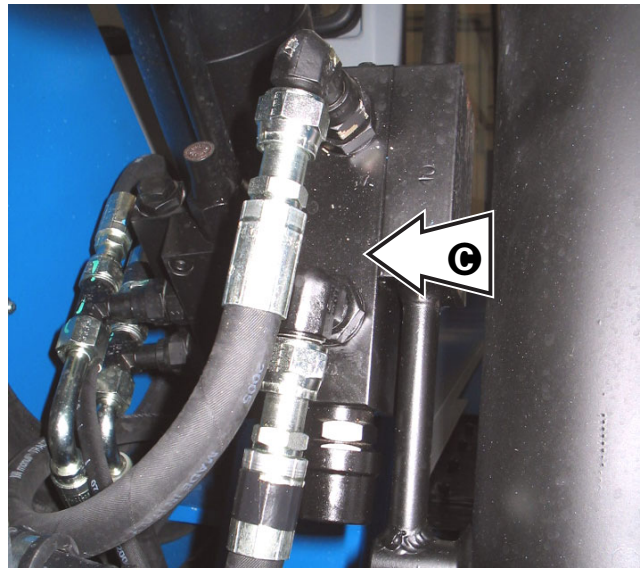

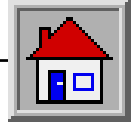

GENERAL INFORMATION

■ A-4 GENERAL DESCRIPTION

■ A-4.1 LIST OF THE MAIN COMPONENTS

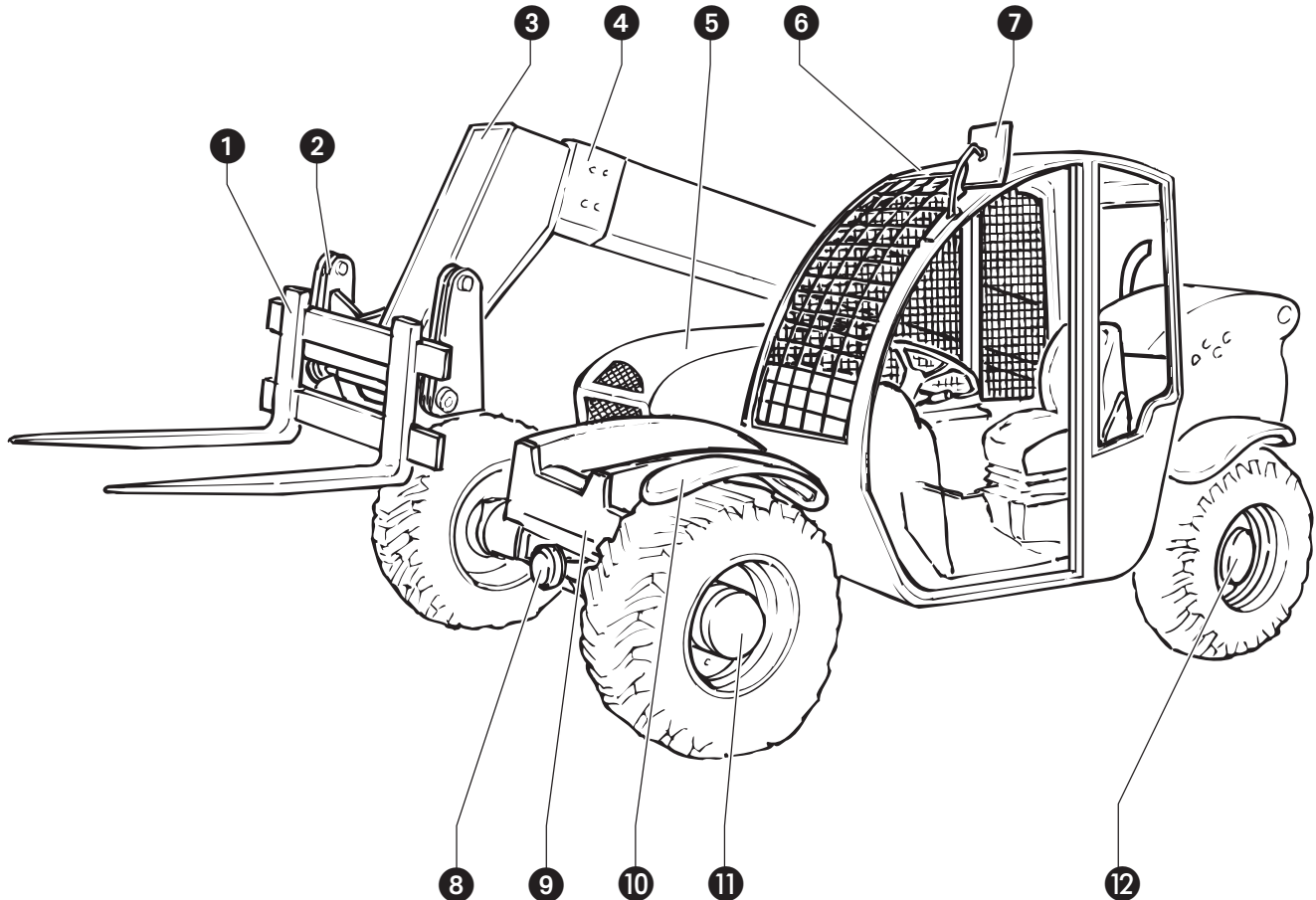

- 1 - Forks
- 2 - Attachment holding frame
- 3 - 2nd boom section
- 4 - 1st boom section
- 5 - Engine hood
- 6 - Driving cab
- 7 - Left rear view mirror
- 8 - Front axle
- 9 - Chassis
- 10 - Left front wheel mud-guard
- 11 - Left front wheel reduction gear
- 12 - Left rear wheel reduction gear

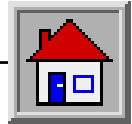

GENERAL INFORMATION

■ A-4.2 DESCRIPTION OF THE MAIN COMPONENTS

Hydrostatic transmission

This unit consists of parts which drive the machine shifting, and namely:

- a variable displacement pump connected to the thermal engine by an elastic joint
- a motor with variable displacement and automatic adjustment in relation to the wheel torque required, complete with power divider, directly applied on the rear axle
- a hydraulic oil filter, placed on the discharge line to the tank
- a heat exchanger to cool the circuit down.

Motion is transmitted to the rear axle from the power divider through a Cardan shaft.

Engine

The thermal engine is equipped with a heat exchanger which uses the engine oil as cooling medium.

Steering axles/(front and rear) differential gears

The differential axles transmit the motion to the wheels. The locking device acting on the front axle enables the machine to move also on low grip grounds.

Tyres

The machine is equipped with tyres suitably sized for the maximum load allowed on the handler. When worn, they shall be replaced with new ones having the same dimensions and loading capacity.

Boom hydraulic circuit

It consists of a gear pump connected to the thermal engine which, through a special valve, dispenses oil to the hydraulic drive and a distributor for the following functions:

- boom lifting/lowering
- telescopic boom extension/retraction
- attachment rotation
- attachment locking

Braking circuit

It consists of an independent circuit: the pedal directly acts on the brake pump which dispenses oil to the front axle braking unit with discs in oil bath.

The parking brake, of negative type, acts on the braking unit of the service brake. This brake is engaged every time the handler's engine is stopped or pressing down the light pushbutton located to the right of the driving place.

Telescopic boom

The machine is equipped with a telescopic boom with hydraulic-driven extension. The telescopes slides on interchangeable pads made of wearproof material.

Driving cab

Type-approved driving cab in compliance with standards ANSI/ASME B56.6-2002.

■ A-4.3 OPTIONAL ACCESSORIES

The machine can be fitted with a wide range of optional accessories: please address to **Genie** sales network.

IMPORTANT

Please check the accessories available for your machine.

■ A-4.4 KITS SUPPLIED ON REQUEST

The machine is prepared for the installation of the following assembly kits:

- Driving cab glasses (including door)
- Heater
- Air conditioning
- Work lights (including courtesy lamp in the cab)
- Beacon

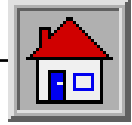

GENERAL INFORMATION

A-5 TECHNICAL DATA AND PERFORMANCE

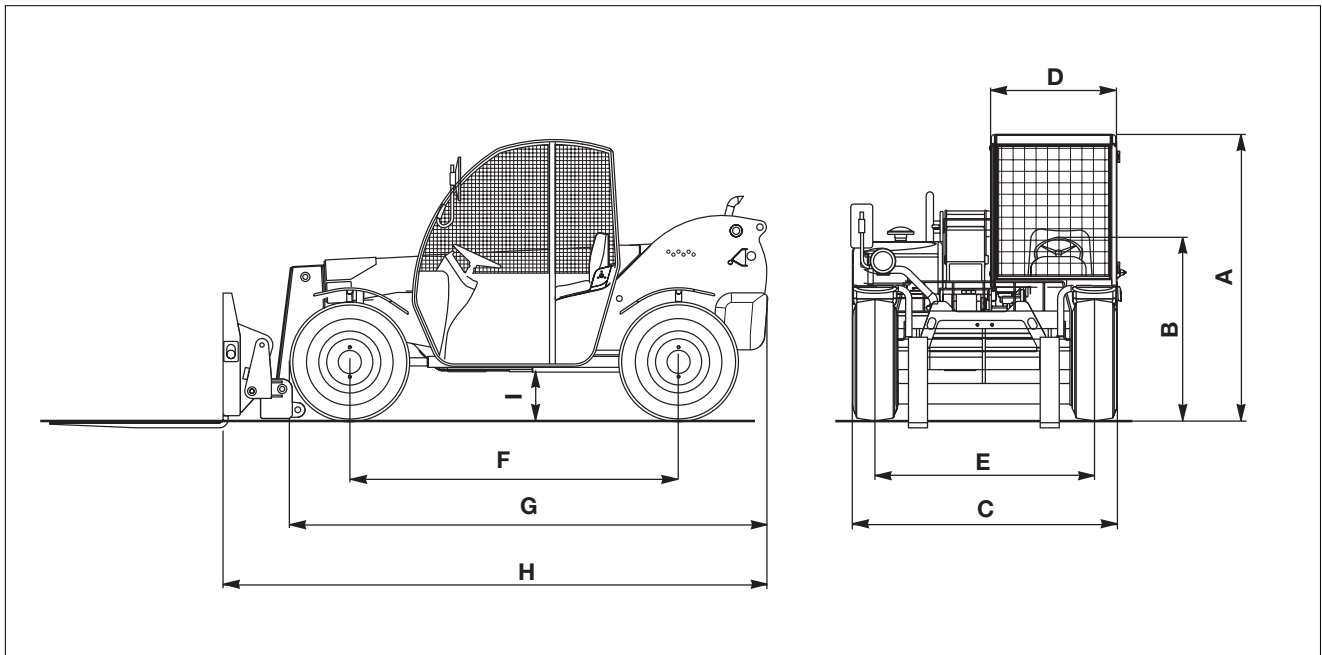

A-5.1 MAIN DIMENSIONS

		GTH-5519
A	Overall height	ft 6' - 3.60"
B	Height to the steering wheel	ft 4' - 0.50"
C	Overall width	ft 5' - 10.92"
D	Cab width	ft 2' - 9.84"
E	Track	ft 4' - 10.92"
F	Wheel-base	ft 7' - 5.76"
G	Length to the front tyres	ft 10' - 10.32"
H	Length to the attachment holding plate	ft 12' - 2.40"
I	Ground clearance	ft 1' - 2.16"
•	Internal steering radius	ft 5' - 8.16"
•	External steering radius	ft 11' - 1.80"

A-5.2 RESTRICTIONS OF USE

•	Angle of approach	90°
•	Departure angle	70°
•	Ambient temperature	°C -20°/+40°

A-5.3 WEIGHT

•	Weight in working order (with forks)	lb 9855
---	--------------------------------------	---------

A-5.4 SPEED

-	Travel speed	mph 15
-	Max. slope with full load	60%

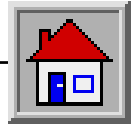

GENERAL INFORMATION

■ **A-5.5 PAYLOAD AND REACH**

GTH-5519

- Max lifting height	ft	18' - 10.32"
- Reach at max height	ft	1' - 5.76"
- Max reach forward	ft	10' - 11.52"
- Attachment holding plate rotation		135°
- Maximum payload	lb	5500
- Payload at max height	lb	2600
- Payload at max reach	lb	1700

■ **A-5.6 FORKS Floating type**

- Dimensions	ft	3'-11.28" x 0'-3.86" x 0'-1.56"
- Weight	lb	114 + 114

■ **A-5.7 DIESEL ENGINE**

Aspirated version

- Make		DEUTZ AG
- Model/Type		F4M 2011
- Features:		Diesel
		4 cylinders in line
		4 strokes
		direct injection
- Bore x Stroke	in	3.7" x 4.41"
- Total displacement	cu in	189.65
- Power at 2600 rpm (ISO 3046 IFN)	kW	46,5

■ **A-5.8 ELECTRICAL SYSTEM**

- Voltage	V	12
- Battery	Ah	100

IMPORTANT

This is a device of Class A. In a residential environment, such device can cause radio disturbance. In such cases, the operator is required to take suitable measures.

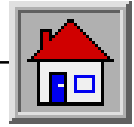

GENERAL INFORMATION

■ A-6 LIFETIME

The lifetime of the machine is 10 000 hours provided all checks, service jobs and overhauls are done at the times scheduled.



After this time, the machine must compulsorily be inspected and tested by the Manufacturer before being used again.

■ A-7 ITEMS SUPPLIED

The following items are supplied together with the machine:

Description	GTH-5519
- Spanner CH 19 (for fork positioning)	x
- Allen wrench CH 6 (for fork positioning)	x
- 12 V lamps (spare)	x

■ A-7.1 LITERATURE SUPPLIED

The machines comes with the following literature:

- Machine operator's handbook
- DEUTZ engine use and maintenance manual

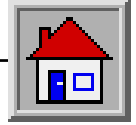

GENERAL INFORMATION

Intentionally blank page

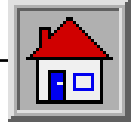

SAFETY

Section B

SAFETY

TABLE OF CONTENTS

B-1	GENERAL REMARKS	B-2
B-2	PREREQUISITES OF THE PERSONNEL IN CHARGE	B-2
B-2.1	Requisites of the machine operators	B-2
B-2.2	Requisites of the servicemen	B-3
B-2.3	Working clothes	B-3
B-2.4	Personal protective equipment	B-3
B-3	SAFETY PRECAUTIONS	B-4
B-3.1	Job site	B-4
B-3.2	Getting ready to work	B-5
B-3.3	During work or maintenance	B-5
B-4	SAFETY DEVICES	B-7

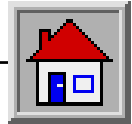

SAFETY

■ B-1 GENERAL REMARKS

Most accidents occurring while working, repairing or maintaining operation machines, are caused by not complying with the basic safety precautions. Therefore, it is necessary to pay steady attention to the potential hazards and the effects that may come of operations carried out on the machine.

IMPORTANT

If you recognise hazardous situations, you can prevent accidents!

For instance, this handbook makes use of special **safety symbols** to stress any potentially hazardous situation.

 **CAUTION**

The instructions given in this handbook are the ones established by GENIE. They do not exclude other safe and most convenient ways for the machine installation, operation and maintenance that take into account the available spaces and means.

If you decide to follow instructions other than those given in this manual, you shall absolutely:

- be sure that the operations you are going to carry out are not explicitly forbidden;
- be sure that the methods are safe, say, in compliance with the rules and provisions given in this section;
- be sure that the methods cannot damage the machine directly or indirectly or make it unsafe;
- contact GENIE Assistance Service for any suggestion and the necessary written permission.

IMPORTANT

If in doubt, it is always better to ask! For this purpose, contact GENIE: the assistance service is at your disposal. Addresses, phone and fax numbers are given in the cover and in the title-page of this manual.

■ B-2 REQUISITES OF THE PERSONNEL IN CHARGE

■ B-2.1 REQUISITES OF THE MACHINE OPERATORS

The operators who use the machine regularly or occasionally (i.e. for transport reasons) shall have the following prerequisites:

health:

before and during any operation, operators shall never take alcoholic beverages, medicines or other substances that may alter their psycho-physical conditions and, consequently, their working abilities.

physical:

good eyesight, acute hearing, good co-ordination and ability to carry out all required operations in a safe way, according to the instructions of this manual.

mental:

ability to understand and apply the enforced rules, regulations and safety precautions. They shall be careful and sensible for their own as well as for the others' safety and shall desire to carry out the work correctly and in a responsible way.

emotional:

they shall keep calm and always be able to evaluate their own physical and mental conditions.

training:

they shall read and familiarise with this handbook, its enclosed graphs and diagrams, the identification and hazard warning plates. They shall be skilled and trained about the machine use.

IMPORTANT

The operator shall have a licence (or a driving licence) when provided for by the laws enforced in the country where the machine works. Please, ask the competent bodies. In Italy the operator must be at least 18 year old.

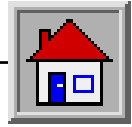

SAFETY

■ B-2.2 REQUISITES OF THE SERVICEMEN

The personnel charged with the machine maintenance shall be qualified, specialised in the maintenance of earth-moving machines, and shall have the following prerequisites:

physical:

good eyesight, acute hearing, good co-ordination and ability to carry out all required maintenance operations in a safe way, according to this manual.

mental:

ability to understand and apply the enforced rules, regulations and safety precautions. They shall be careful and sensible for their own as well as for the others' safety and shall desire to carry out the work correctly and in a responsible way

training:

they shall read and familiarise with this handbook, its enclosed graphs and diagrams, the identification and warning plates. They shall be skilled and trained about the machine functioning.

■ B-2.4 PERSONAL PROTECTIVE EQUIPMENT

Under special working conditions, the following personal protective equipment should be used:

- Breathing set (or dust mask).
- Ear-protectors or equivalent equipment.
- Goggles or facial masks.

IMPORTANT

Use only type-approved protective equipment in good condition.

IMPORTANT

From a technical point of view, the ordinary maintenance of the machine is not a complex intervention and can be carried out by the machine operator, too, provided he has a basic knowledge of mechanics.

■ B-2.3 WORKING CLOTHES

During work, but especially when maintaining or repairing the machine, operators must wear suitable protective clothing:

- Overalls or any other comfortable garments. Operators should wear neither clothes with large sleeves nor objects that can get stuck in moving parts of the machine.
- Protective helmet.
- Protective gloves.
- Working shoes.

IMPORTANT

Use only type-approved working clothing in good condition.

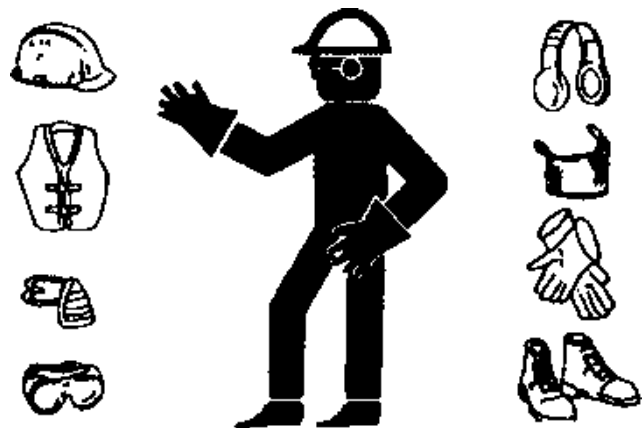

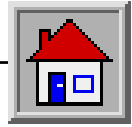

SAFETY

B-3 SAFETY PRECAUTIONS

B-3.1 JOB SITE

Always take into account the features of the job site where you are going to work:

- Always examine the working area and compare it with the machine dimensions in the different configurations.

- Look for the best route to the job site.
- When the machine is running, nobody can enter its working range.
- While working, keep the working area in order. Never leave objects scattered: they could hinder the machine movements and represent a danger for personnel.



Pay the greatest attention to overhead electric lines.

Always keep at a minimum safe distance from the telescopic boom and the lifted load. Electrical hazards!



Do not at any time use the machine during a storm.

DANGER

DEATH OR INJURY CAN RESULT FROM CONTACTING ELECTRIC POWER LINES.

ALWAYS CONTACT THE ELECTRIC POWER LINES OWNER. THE ELECTRIC POWER SHALL BE DISCONNECTED OR THE POWER LINES MOVED OR INSULATED BEFORE MACHINE OPERATIONS BEGIN

POWER LINE VOLTAGE	REQUIRED CLEARANCE
0 to 50 kV	10 ft 3.00 m
50 to 200 kV	15 ft 4.60 m
200 to 350 kV	20 ft 6.10 m
350 to 500 kV	25 ft 7.62 m
500 to 750 kV	35 ft 10.67 m
750 to 1000 kV	45 ft 13.72 m



Make sure the machine (wheels and stabilisers) rests on a firm ground to prevent hazardous unstable conditions.

If the ground is not firm enough, position some supporting planks under the stabilisers or the wheels. These plates must grant a specific pressure of 1.2 to 1.5 kg/cm² (500x500mm plates are sufficient).

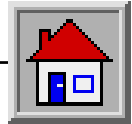

SAFETY

■ **B-3.2 GETTING READY TO WORK**

Before any operation, following precautions should be taken:

- First of all, make sure that the maintenance interventions have been carried out with care according to the established schedule (see section **D - Maintenance**).



Set the machine to working configuration and sway it checking the special water level in the driving cab, at the top on the strut.

- Ensure you have enough fuel to avoid a sudden stop of the engine, especially during a crucial manoeuvre.
- Clean instruments, data plates, lights and the cab windscreen thoroughly.
- Check the correct functioning of all the safety devices installed on the machine and in the job site.
- In case of troubles or difficulties, inform the foreman at once. Never start working under unsafe conditions.
- Do not carry out any repair work in a makeshift way to start working!

■ **B-3.3 DURING WORK OR MAINTENANCE**

During work, and especially maintenance, always pay the greatest attention:

- Do not walk or stop under raised loads or machine parts supported by hydraulic cylinders or ropes only.
- Keep the machine handholds and access steps always clean from oil, grease or dirt to prevent falls or slips.



- When entering/leaving the cab or other raised parts, always face the machine; never turn the back.
- When carrying out operations at hazardous heights (over **1.5 meters** from the ground), always use type-approved safety belts or fall preventing devices.



- Do not enter/leave the machine while it is running.
- Do not leave the driving place when the machine is running.
- Neither stop nor carry out interventions under or between the machine wheels when engine is running. When maintenance in this area is required, stop the engine.



- Do not carry out maintenance or repair works without a sufficient lighting.
- When using the machine lights, the beam should be oriented in order not to blind the personnel at work.
- Before applying voltage to electric cables or components, check their connection and proper functioning.
- Do not carry out interventions on electric components with voltage over **48V**.
- Do not connect wet plugs or sockets.
- Plates and hazard warning stickers shall never be removed, hidden or become unreadable.

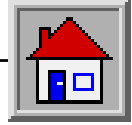

SAFETY

- Except for maintenance purposes, do not remove safety devices, shields, protection cases, etc. Should their removal be necessary, stop the engine, remove them with the greatest care and always remember to refit them before starting the engine and using the machine again.
- Before any maintenance or repair work, stop the engine and disconnect the batteries.
- Do not lubricate, clean or adjust moving parts.
- Do not carry out operations manually when specific tools are provided for this purpose.
- Absolutely avoid to use tools in bad conditions or in an improper way i.e. pliers instead of adjustable wrenches, etc.
- Before carrying out operations on hydraulic lines under pressure or disconnecting hydraulic components, ensure the relevant line has been previously depressurised and does not contain any hot fluid.



Any intervention on the hydraulic circuit must be carried out by authorised personnel.

The hydraulic circuit of this machine is fitted with pressure accumulators. You and others could be seriously injured if accumulators are not completely depressurised.

For this purpose, shut the engine down and step on the brake pedal 8÷10 times.

- Neither smoke nor use open flames in areas subject to fire dangers and in presence of fuel, oil or batteries.

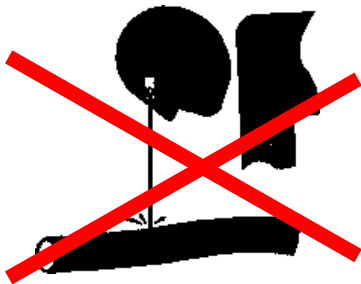

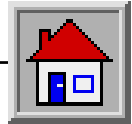

SAFETY

- Do not leave fuel cans or bottles in unsuitable places.
- Do not empty catalytic mufflers or other vessels containing burning materials without taking the necessary precautions.
- Carefully handle all flammable or dangerous substances.

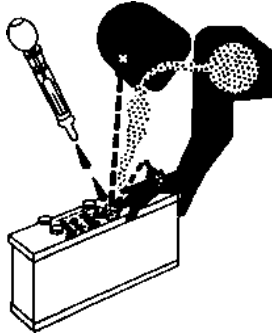

B-4 SAFETY DEVICES



Several safety devices have been fitted to the machine. They must never be tampered with or removed (see chap. A-3.5).

Regularly check the efficiency of such devices (see check card, chap. G-5).

In case of faults, stop working immediately and proceed in replacing the defective device.

For the checking procedures, read chap. D-3.14

- Do not tamper with fire-extinguishers or pressure accumulators: **explosion hazard!**
- After any maintenance or repair work, make sure that no tool, cloth or other object has been left within machine compartments, fitted with moving parts, or where suction and cooling air circulates.
- When working, do not give instructions or signs to several people at the same time. Instructions and signs must be given by one person only.
- Always pay the due attention to the instructions given by the foreman.
- Never distract the operator during working phases or crucial manoeuvres.
- Do not call an operator suddenly, if unnecessary.
- Do not frighten an operator or throw objects by no means.
- After work, never leave the machine under potentially dangerous conditions.

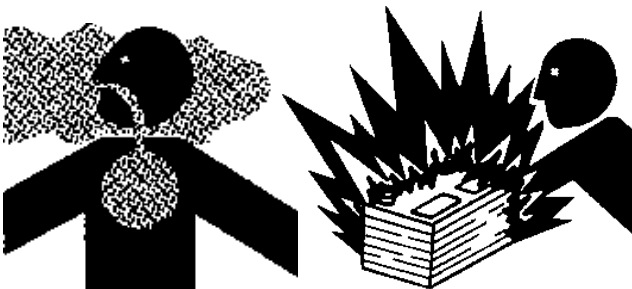

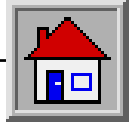

SAFETY

Intentionally blank page

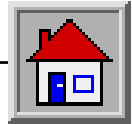

OPERATING INSTRUCTIONS

Section C

OPERATING INSTRUCTIONS

TABLE OF CONTENTS

C-1	BEFORE ENTERING THE MACHINE	C-2	C-3.4.5	Quick-coupling the attachments	C-19
C-2	ENTERING THE MACHINE	C-3	C-4	SETUP	C-20
C-2.1	Entering the cab (only with cabin		C-4.1	Before starting the engine	C-20
	closed or glass kit installed)	C-3	C-4.1.1	Checks at the machine start-up	C-20
C-2.1.1	Emergency exit-way (only with cabin		C-4.2	Starting the engine	C-20
	closed or glass kit installed)	C-4	C-4.3	Jump-starting the engine.....	C-21
C-2.2	Adjusting the seat	C-5	C-4.4	Low temperature starting	C-22
C-2.3	Fastening the seat belts	C-5	C-4.5	Disconnecting the battery.....	C-22
C-2.4	Adjusting the steering column	C-6	C-4.6	Starting the machine.....	C-22
C-2.5	Adjusting the rear view mirrors	C-6	C-4.7	Stopping and parking the machine	C-23
C-2.6	Switching on the cab interior lamp	C-6	C-5	USING THE HANDLER	C-23
C-3	DRIVING PLACE	C-7	C-5.1	Using the load charts.....	C-25
C-3.1	Controls and instruments	C-7	C-5.2	Handling loads	C-25
C-3.2	Engine controls and instruments	C-9	C-5.2.1	Adjusting the floating forks	C-25
C-3.2.1	Ignition switch.....	C-9	C-5.2.2	Working phases	C-26
C-3.2.2	Forward/reverse gear switch	C-9	C-5.3	Changing the attachment	C-27
C-3.2.3	Brakes.....	C-10	C-6	TRANSPORTING THE MACHINE	C-28
C-3.2.4	Accelerator control	C-10	C-6.1	Moving a disabled machine	C-28
C-3.2.5	Pushbutton enabling the attachment		C-6.1.1	Unlocking the negative brake	C-28
	coupling/release	C-11	C-6.2	Road or site transfer	C-28
C-3.2.6	Steering mode selection	C-11	C-6.3	Lifting the machine	C-29
C-3.2.7	Road/Jobsite switch	C-11	C-6.4	Transporting the machine on other	
C-3.2.8	Auxiliary drive controls	C-12		vehicles	C-29
C-3.3	Instruments and light indicators	C-12	C-6.5	Parking and storage	C-30
C-3.3.1	Instruments	C-12	C-6.5.1	Short inactivity	C-30
C-3.3.2	Light indicators	C-13	C-6.5.2	Machine storage	C-30
C-3.4	Control lever	C-14	C-6.6	Cleaning and washing the machine	C-31
C-3.4.1	Function selection	C-14	C-6.6.1	Cleaning instructions	C-31
C-3.4.2	Lifting/lowering the boom.....	C-16	C-6.6.2	Washing instructions	C-31
C-3.4.3	Pitching the attachment holding frame		C-6.7	Machine disposal.....	C-31
	forwards/backwards	C-17	C-6.7.1	Disposal of batteries	C-31
C-3.4.4	Extending/retracting the telescope	C-18			

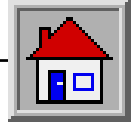

OPERATING INSTRUCTIONS

INTRODUCTION

This section provides the operator a practical guide for the gradual learning of the machine use.

The operator should get into the driving cab and carry out the preliminary adjustments, then memorise the position of the different controls and instruments.

The familiarisation with the controls ensures not only a correct use during the working phases, but also a prompt and timely intervention of the operator, when he shall carry out sudden manoeuvres to safeguard his safety and the machine integrity.

It is necessary to learn how to use and foresee the machine reactions. Learn how to operate the machine controls in a safe and open place, without obstacles and anybody standing around. Do not ram the controls. Operate them slowly to understand their effect on the machine.

C-1 BEFORE ENTERING THE MACHINE

Checks and cleaning

- Clean glasses, lights and rear view mirrors.
- Check that pins, joints and bolts are well tightened in position.
- Check for oil, fuel or coolant leaks.

Checking the tyres

- Check the correct inflation of the tyres; see par. "**Tyre inflation**" in the Maintenance section.
- Make sure that the tyre plies are not cut or worn.



DANGER

A tyre burst may result in serious injury; never use the machine if tyres are worn, wrongly inflated or damaged.

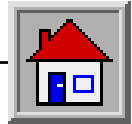

OPERATING INSTRUCTIONS

C-2 ENTERING THE MACHINE

**C-2.1 ENTERING THE CAB
(ONLY WITH CABIN CLOSED OR
GLASS KIT INSTALLED)**



Always make sure that your hands and shoe soles are clean and dry before getting into the driving cab. Always face the machine when entering and leaving it and hold to the suitable handles.

The handler cab is equipped with an access door on the left-hand side.

Door opening from outside:

- Insert the key and release lock 1.
- Press the pushbutton and open the door.



Door closing from inside:

- Pull the door with force: it locks automatically.

Door opening from inside:

- Lift lever 2 and release the lock to open the door completely.
- Rotate handle 3 to open the upper section of the door and lock it against the special catch.

To unlock the door latched in open position:

- Press button 4 to unlock the door from the catch, close and latch the door to the lower section using handle 3.



The upper section of the door must be secured to the rear part of the driving cab or latched to the lower section of the same door.

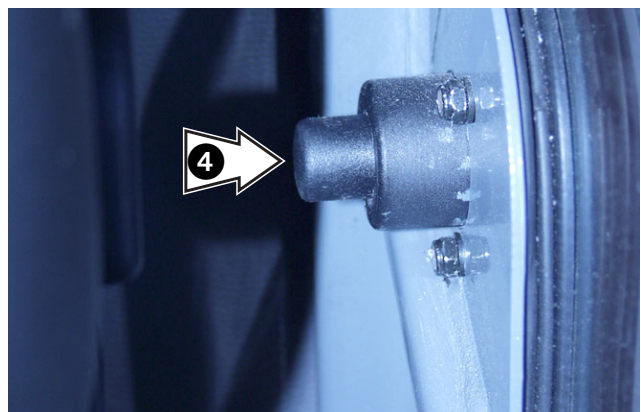
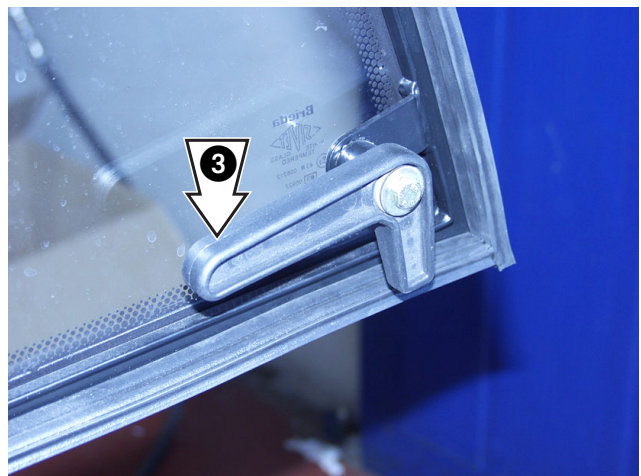
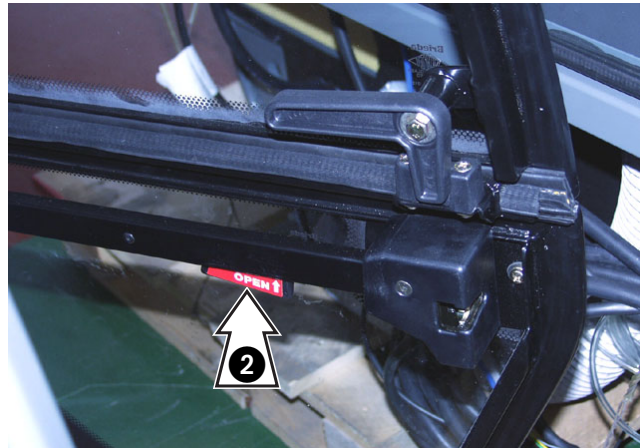

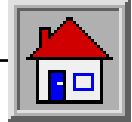

OPERATING INSTRUCTIONS

■ C-2.1.1 *Leaving the cab in an emergency* **(ONLY WITH CABIN CLOSED OR GLASS KIT INSTALLED)**

In an emergency, the operator can use the front or the rear window as safety exit-ways.

The rear window has handles for partially opening the glass. Such handles are locked in position by some wing nuts **5** which, if driven out, allow opening the glass completely.

The front window has two handles **6** which, if turned, enable the operator to pass through.

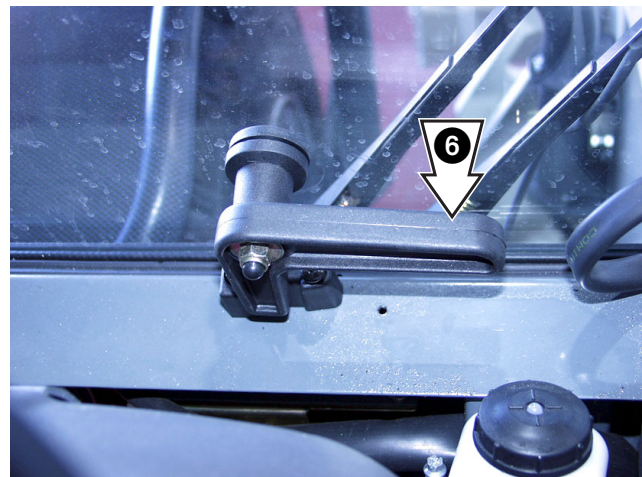
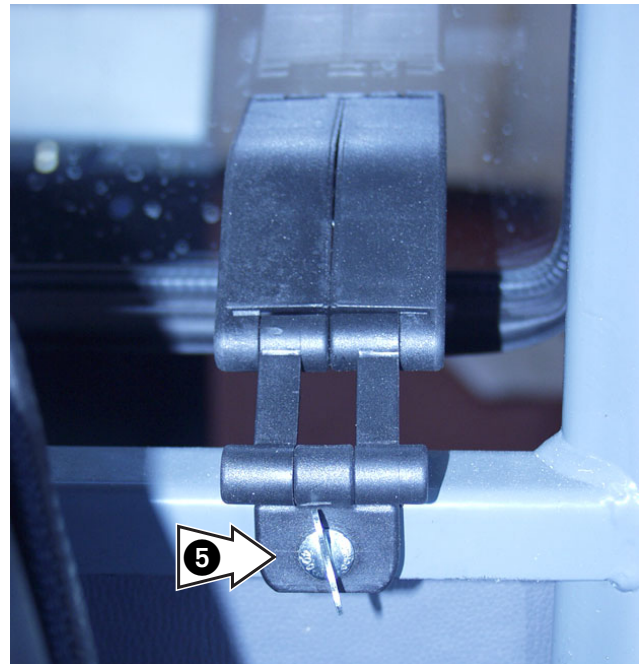

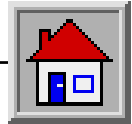

OPERATING INSTRUCTIONS

■ C-2.2 ADJUSTING THE SEAT

A correct adjustment of the seat ensures the operator a safe and comfortable driving. The handler seat is fitted with devices which allow for the adjustment of the springing, the height and the distance from the controls.

• **Seat distance from the controls**

The seat is equipped with an adjusting device to slide the same seat forward or back with respect to the steering column.

To adjust the seat, pull lever **1** outwards and push the seat to the desired direction. Then release the lever and make sure that the seat locks in position.

• **Springing adjustment (optional)**

Rotate lever **2** clockwise or anticlockwise according to the springing degree required. Rotate clockwise/ anticlockwise to increase/reduce the seat springing. To reverse this control, pull out and rotate the lever knob by 180°.

• **Height adjustment (optional)**

Turn knob **3** clockwise to lift the seat; turn it counter-clockwise to lower the seat.

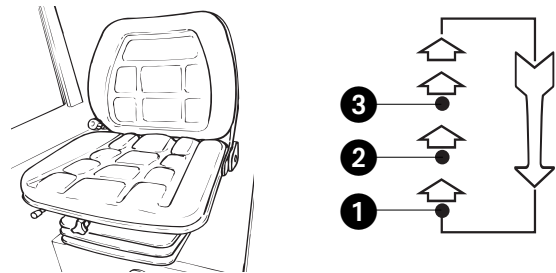

In some seats height can be adjusted to three different positions. Lift the seat until you hear the click signalling that the seat is locked in position. To lower the seat, raise to end of stroke to release the mechanism, then release the seat: it will return to the bottom position.

■ C-2.3 FASTENING THE SEAT BELTS

Sit correctly in the driving seat; then:

- The safety belts are equipped with reel retractor. To fasten the belt, pull tab **1** and push it into buckle **2**.
- To release the belt, push button **3** and remove the tab from the buckle.
- Make sure that the buckle is correctly located at the hip point and not on the stomach.
- Operate the end adjusters to reach the length you wish and make sure the buckle is always in the middle.

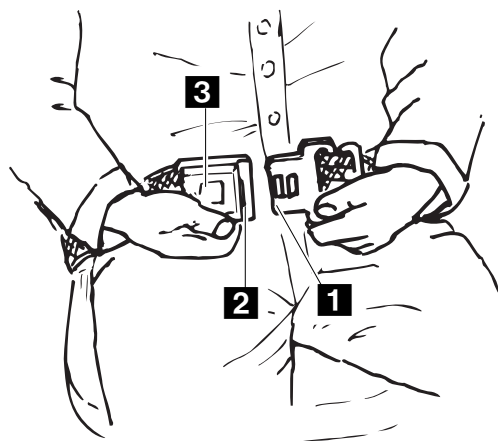
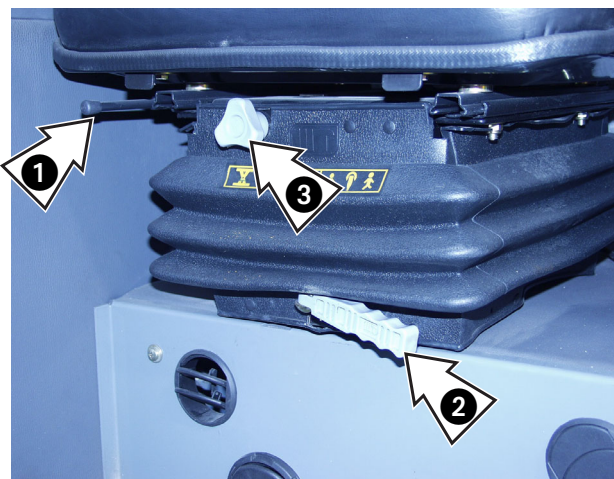

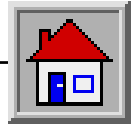

OPERATING INSTRUCTIONS

■ **C-2.4 ADJUSTING THE STEERING COLUMN**

Both steering column and dashboard can be set to a different angle. For this purpose:

- Loosen lever **1** and adjust as required, then re-tighten lever **1**.



Before driving the machine, ensure the steering wheel is perfectly clamped.

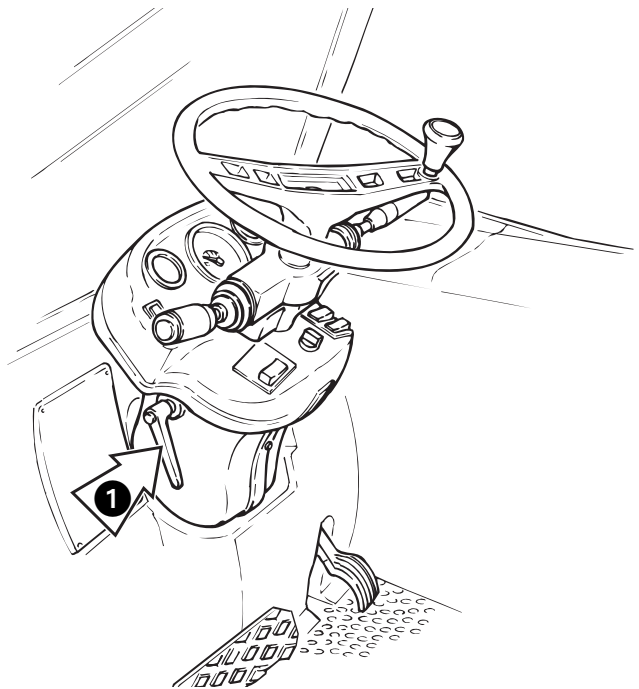

■ **C-2.5 ADJUSTING THE REAR VIEW MIRRORS**

The machine is fitted with two rear view mirrors:

- The right rear view mirror is located on a special supporting bracket in advanced position and allows checking the area behind the machine, on the right-hand side. To adjust its position, manually rotate the joint it is fitted with.
- The left rear view mirror is placed on the left upper post of the windscreen and allows checking the area behind the machine, on the left-hand side. To adjust its position, manually rotate the joint it is fitted with.

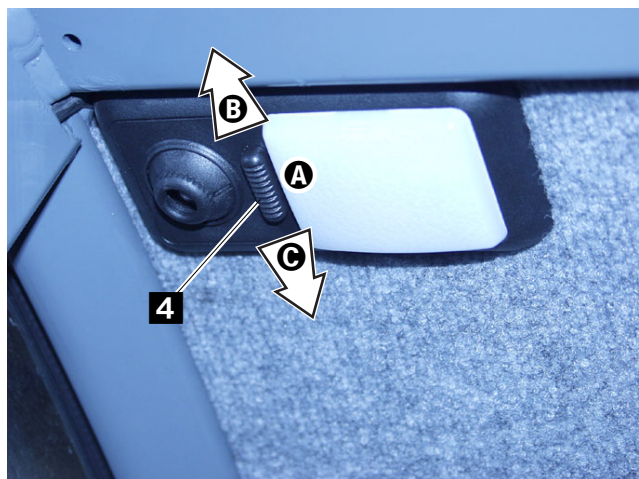
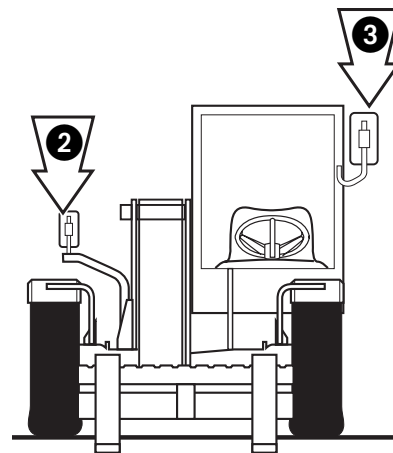

■ **C-2.6 SWITCHING ON THE CAB LIGHTS**

The ceiling light fixture of the cab has an internal lamp and a courtesy lamp.

To switch on the cab interior lights:

- Switch **4** in pos. **A** cab interior lights OFF
- Switch **4** in pos. **B** cab interior lights ON.
- Switch **4** in pos. **C** courtesy lamp ON

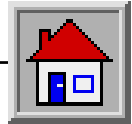
**OPERATING INSTRUCTIONS****C-3 DRIVING PLACE****C-3.1 CONTROLS AND INSTRUMENTS**

- 1 Dashboard
- 2 Water level
- 3 Brake oil tank
- 4 Ignition switch
- 5 Fresh air flap
- 6 Warning light - glow plugs preheating
- 7 Warning light - air filter clogged
- 8 Fuse compartment
- 9 Forward/reverse speed selection lever
- 10 Steering column locking lever
- 11 Brake pedal
- 12 Pushbutton enabling the attachment coupling/
release
- 13 Steering selection switch
- 14 Horn pushbutton
- 15 Gas pedal
- 16 Seat
- 17 Control lever
- 18 Negative brake on/off switch
- 19 Continuous flow selector
- 20 Storage tray
- 21 Storage pocket
- 22 Windscreen washer pushbutton (only with cabin
closed)
- 23 Air conditioning fan switch (only with cabin closed)
- 24 Cab heater cock (only with cabin closed)

IMPORTANT

The warning lights, controls and instruments not indicated in this list or in the drawings on the following pages are part of the optional assembly kits. When looking for one of such devices, please refer to the pages of the specific assembly kit at the end of this manual or to the specific installation instructions.

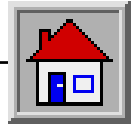

OPERATING INSTRUCTIONS

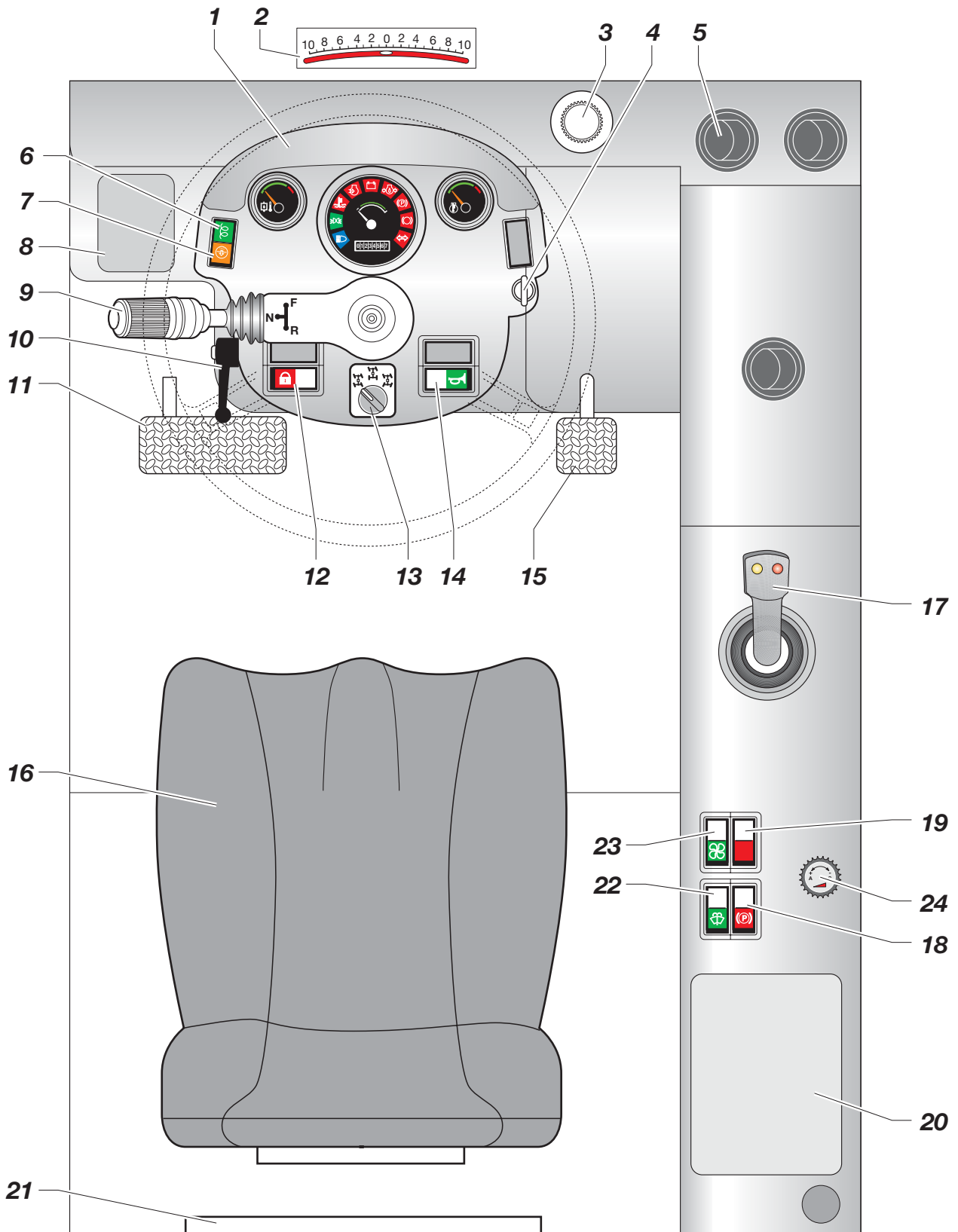

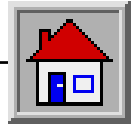

OPERATING INSTRUCTIONS

C-3.2 ENGINE CONTROLS AND INSTRUMENTS

C-3.2.1 Ignition switch

Three-position switch:

- O** No circuit under voltage, key can be removed and engine is stopped
- I** Circuits under voltage, presetting for the engine starting. Board controls and instruments are on. The warning light **6** signalling the glow plugs preheating comes on. Wait until the light goes off before starting the engine.
- II** Engine starting; when released, key springs back to pos. **I** automatically.

C-3.2.2 Forward/reverse gear selector switch

Three-position switch with lock in neutral position:

- N** Neutral position; no gear engaged
- F** Shift lever to pos. **F** to select the forward gear
- R** Shift lever to pos. **R** to select the reverse gear

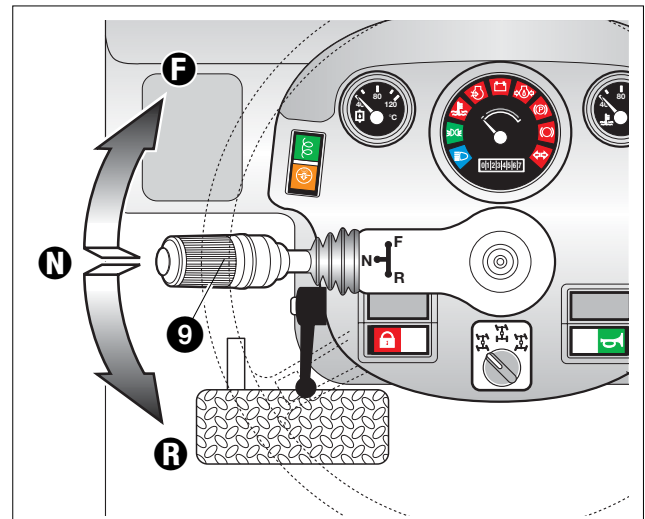
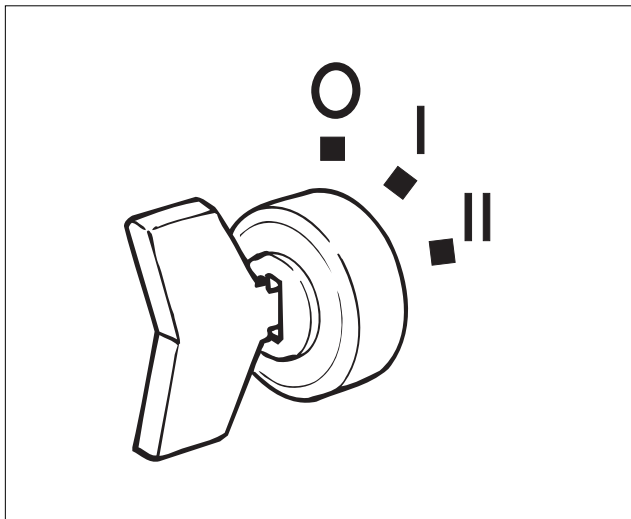

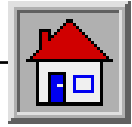

OPERATING INSTRUCTIONS

■ **C-3.2.3 Brakes**

11 Service brake pedal

Gradually step on the brake pedal to decelerate and stop the machine. The pedal operates on the front axle. Fully depressing the brake pedal causes a reset of the displacement of the power drive pump and makes the braking action more powerful.

18 Parking brake

The parking brake of negative type engages automatically when the engine is stopped.

When the handler's engine is restarted, pressing the pushbutton switch **18** unlocks the parking brake.

To stop the handler without shutting down the engine, press the pushbutton switch **18** to engage the parking brake and push it once again to disengage the brake. Every pressure of the pushbutton switches the warning light on and off. When the red warning light is on, the parking brake is engaged.

■ **C-3.2.4 Accelerator control**

15 Gas pedal

Its pressure controls the engine rpm and, coupled to the gearbox, the machine speed. It is fitted with an adjustable stop in the lower part



Never use the parking brake to slow down the machine, unless in an emergency. It may reduce the brake efficiency.

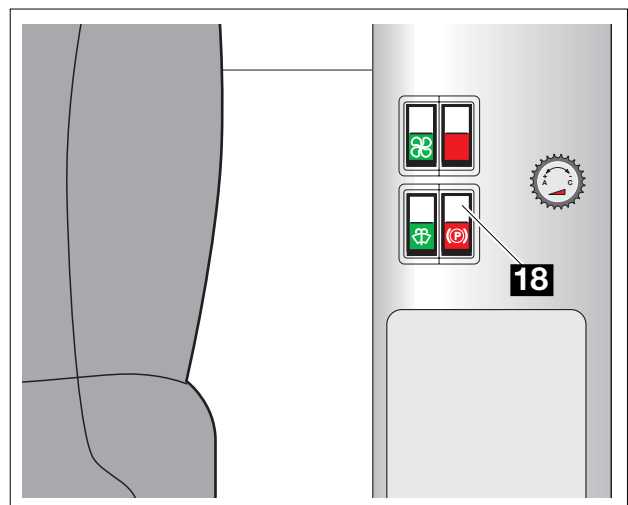
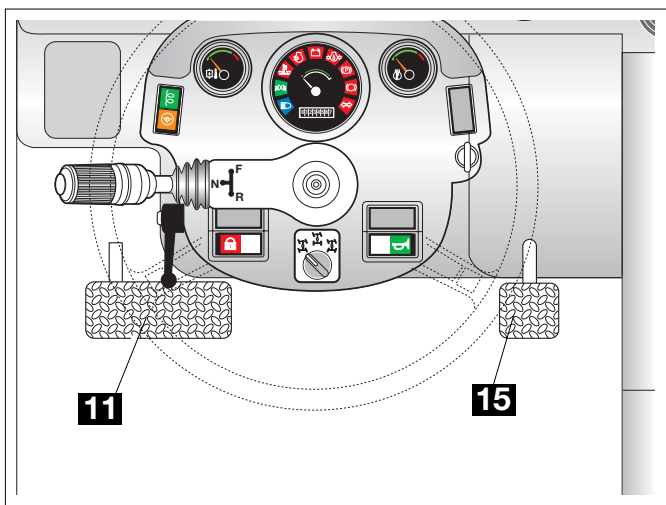

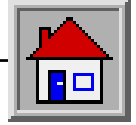

OPERATING INSTRUCTIONS

■ **C-3.2.5 Pushbutton enabling the attachment coupling/release**

12 Selection button

Two-position button with return to the neutral point. Press this button every time you wish to couple/release an attachment. Hold the button pressed down until the movement has been completed.

■ **C-3.2.7 Continuous flow selector**

19 Selection button

Button with two stable positions:



- 1** Pressing this selector delivers a continuous flow of oil to the attachment in use. The built-in light switches on.
- 2** Pressing this selector again lets the circuit returns to normal mode: oil is delivered to the attachment only when the control lever is operated. The built-in light switches off.

■ **C-3.2.6 Steering mode selection**

13 Steering mode switch

Three-position switch for the selection of the steering mode:

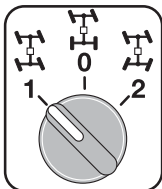

- 1** Crab steering
- 0** Two-wheel steering
- 2** Four-wheel steering

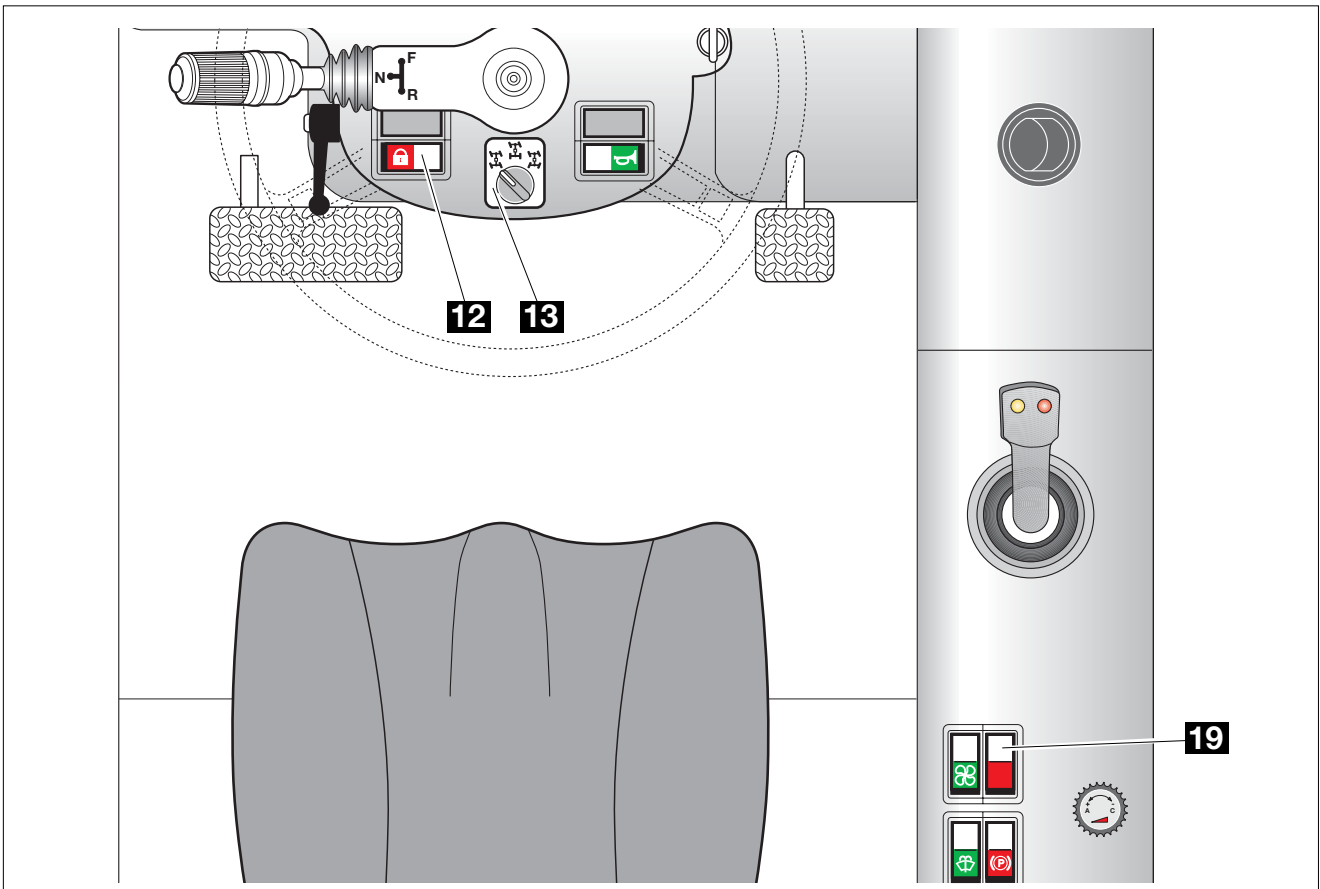

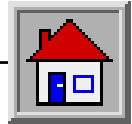

OPERATING INSTRUCTIONS

■ **C-3.2.8 Auxiliary drive controls**

14 Horn pushbutton



Pushbutton with green glass
Press this button to operate the horn.

22 Windscreen washer button



When pushed, it sprays a jet of detergent solution on the windscreen and makes the wiper functioning easier.

23 Air conditioning fan switch (only with cabin closed)



Three-position switch:
0 OFF
1 Low speed
2 High speed

24 Cab heater control cock (only with cabin closed)

To the right of the driving seat.

- Turn the heated air regulator **24** counter-clockwise so the air heating fluid starts circulating. The amount of heated air will be proportional to the opening of the relevant regulator.
- Adjust the heated air operating switch **23** to select one of the three available speeds.
- Open the air flaps and adjust their position to direct the air as you want.
- Turn the heated air regulator clockwise to switch off heated air.

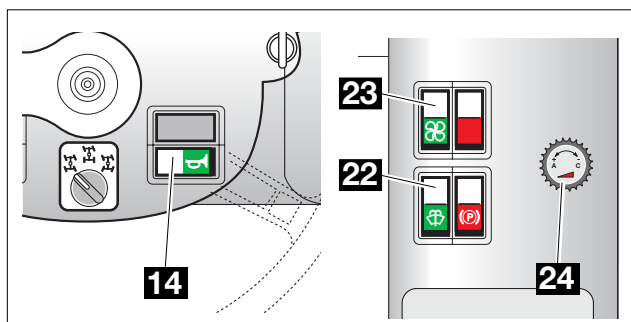

■ **C-3.3 INSTRUMENTS AND LIGHT INDICATORS**

■ **C-3.3.1 Instruments**

54 Engine coolant temperature indicator



Signals the engine coolant temperature. (engine oil)

53 Fuel gauge



Signals the fuel level within the tank.

52 Hour-meter

Signals the total operating hours of the machine.

51 Hydraulic oil temperature indicator



Signals the temperature of the hydraulic oil within the reservoir.

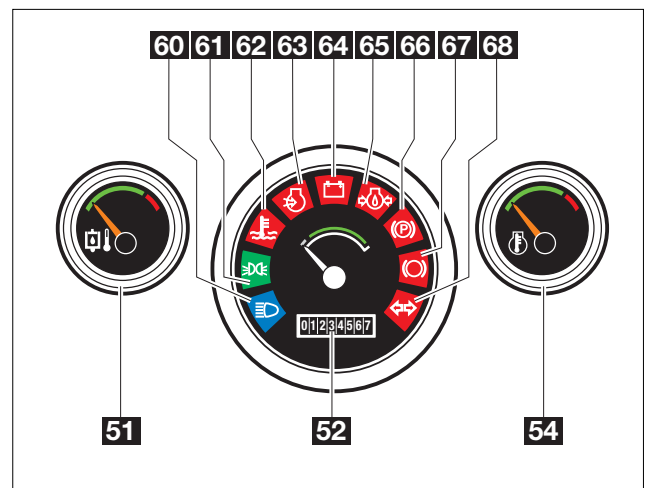

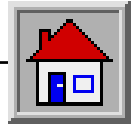

OPERATING INSTRUCTIONS

■ **C-3.3.2 Light indicators**

60 Indicator light - high beam



Blue indicator light that signals when high beam is ON.
This indicator is active only when the lights kit is installed.

61 Indicator light - position lights



Green indicator light that signals when position lights are ON.
This indicator is active only when the lights kit is installed.

63 Indicator light - air filter soiled



Not activated.

64 Indicator light - low battery charge



Signals a low charge by the alternator.

65 Indicator light - low engine oil pressure



It lights when the engine oil pressure is too low.

66 Indicator light - parking brake engaged



When ON, this light indicates that the parking brake is engaged.

67 Indicator light - negative brake accumulator



Not activated.

68 Indicator light - turn signals



Green indicator light that signals when turn signals are ON.
This indicator is active only when the lights kit is installed.

6 Indicator light - glow plugs preheating



Green light indicators which signal the preheating phase of the engine glow plugs. Before starting the engine wait for these lights to go off.

7 Indicator light - air filter soiled



Orange light indicator which signals when the air intake filter of the engine is getting soiled. Clean or replace the filtering cartridge immediately.

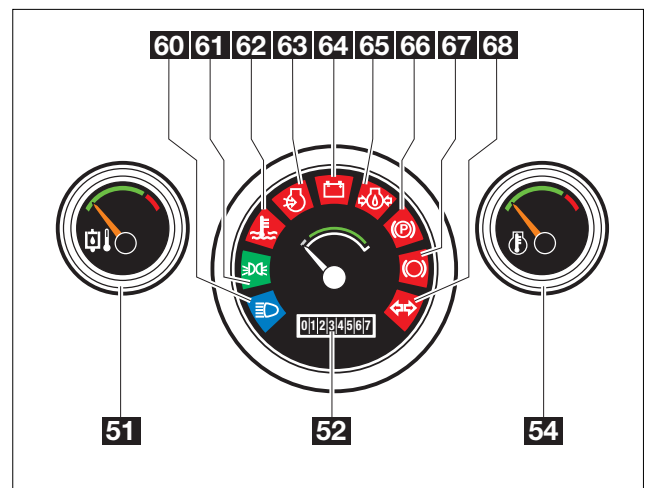
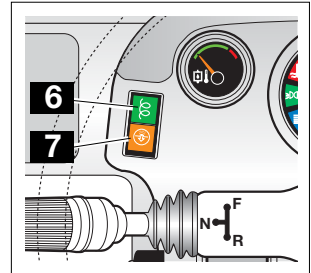

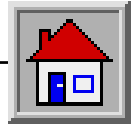

OPERATING INSTRUCTIONS

C-3.4 CONTROL LEVER

Handlers are equipped with a hydraulically driven servo-controlled lever.

The lever has two pushbuttons: one for coupling/releasing the attachments **3** and the other for pitching the attachment frame forwards/backwards **2**. Shifting the lever to one of the four directions (right/left, forwards/backwards) moves the boom up and down and the telescope out and in.

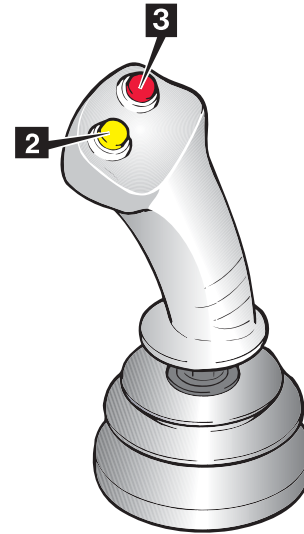

IMPORTANT

Seize the control lever correctly and move it gently. The motion speed of the actuators depends on the lever position: a small motion results in a slow motion of the actuators; vice versa, a full range motion of the lever corresponds to the max. speed of the actuator.

CAUTION

The control lever shall be operated only when correctly seated in the driving place.

CAUTION

Before operating the control lever, make sure that nobody is within the working range of the machine.

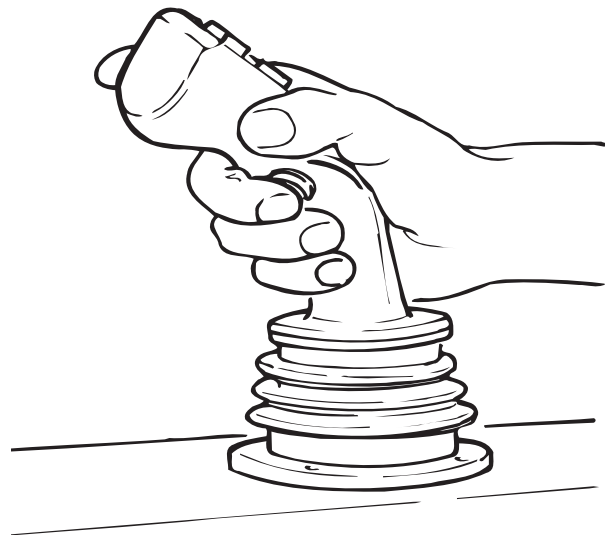

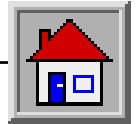

OPERATING INSTRUCTIONS

■ **C-3.4.1 Function selection**

The lever is enabled to carry out the following motions:

- **Boom lowering/lifting**
shift the control lever to **A** or **B**
- **Boom extraction/retraction**
shift the control lever to **C** or **D**
- **Attachment back/forward tilting**
press button **2** and shift the control lever to **A** or **B**
- **Attachment coupling/release**
press button **3** together with the dashboard enabling button and shift the lever to **A** or **B**

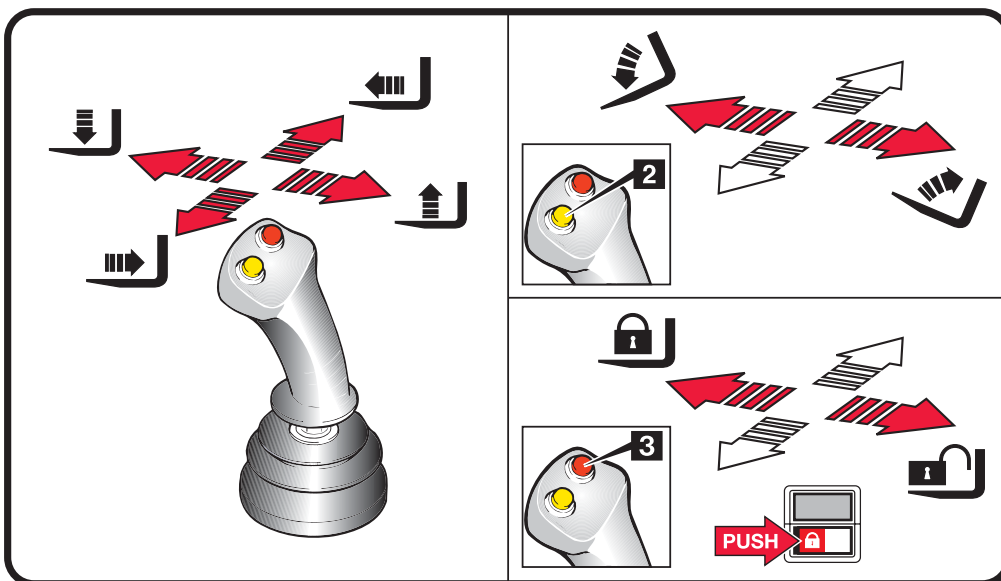
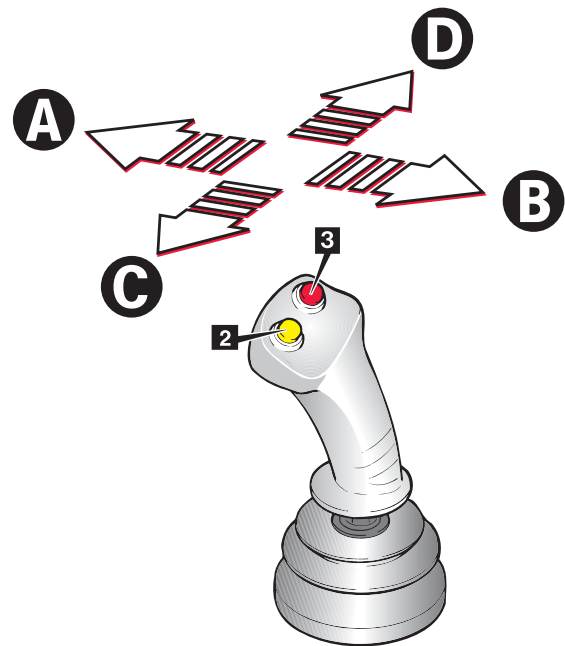

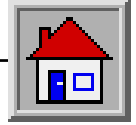

OPERATING INSTRUCTIONS

■ C-3.4.2 Lifting/lowering the boom



Before operating the boom, make sure that nobody is within the working range of the machine.

To lift or lower the boom:

- Smoothly shift the lever to position **B** to lift the boom or to position **A** to lower it.

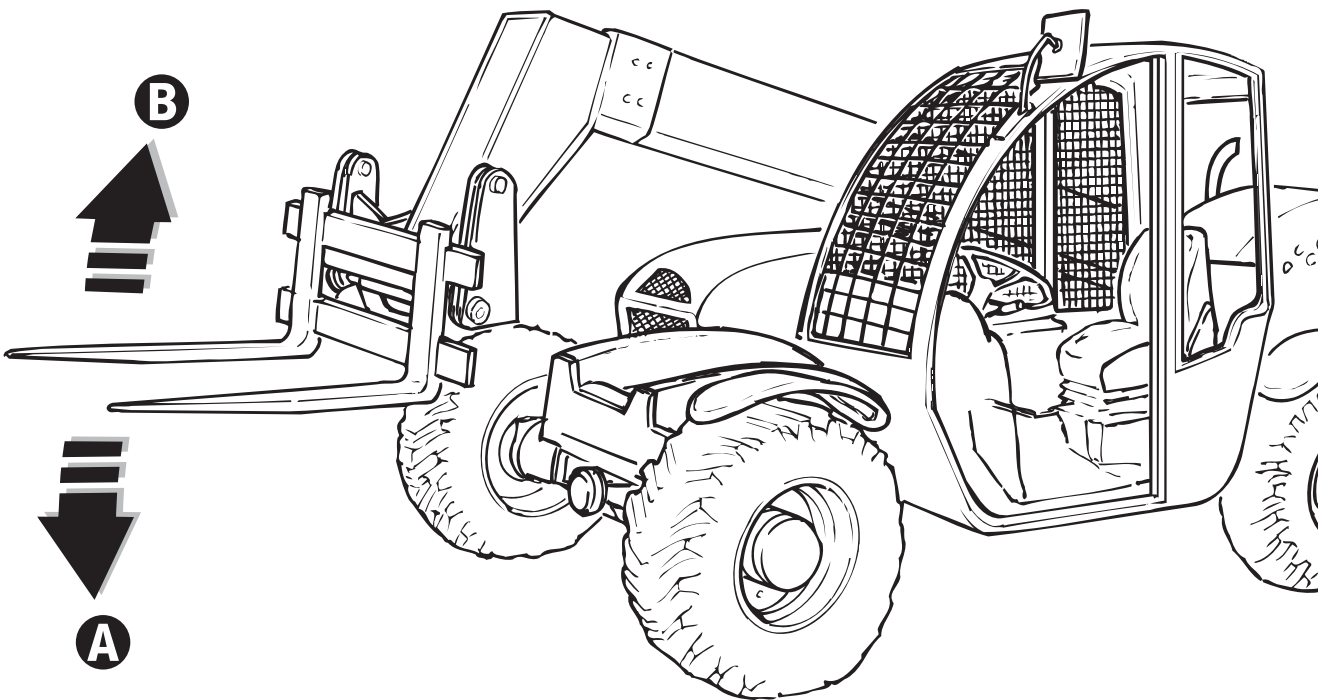
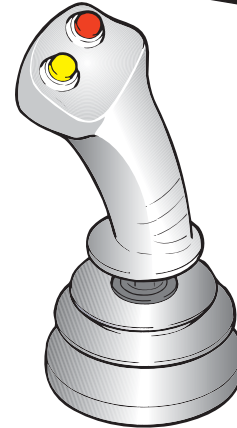
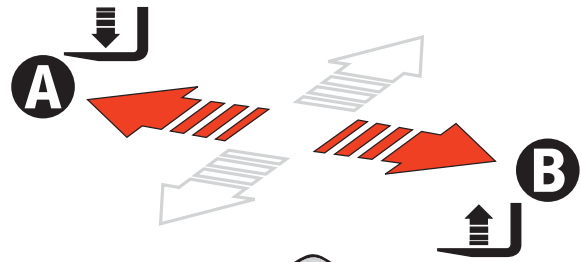

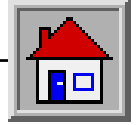

OPERATING INSTRUCTIONS

■ **C-3.4.3** *Pitching the attachment holding frame forwards/backwards*



Before operating the boom, make sure that nobody is within the working range of the machine.

To tilt the attachment holding frame forwards/backwards:

- Press button **2** and shift the lever to position **A** to tilt the frame forwards or to position **B** to tilt it backwards.

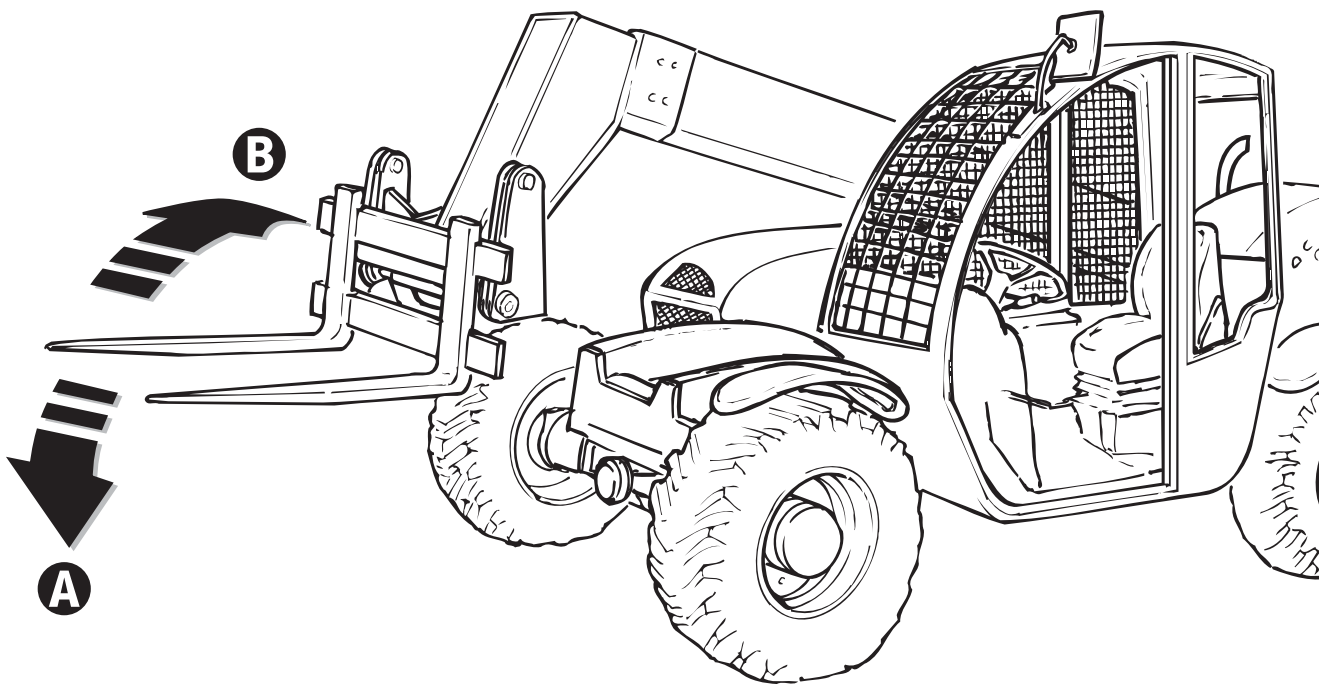
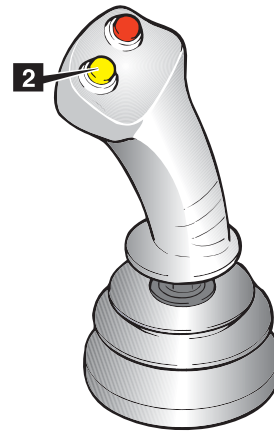
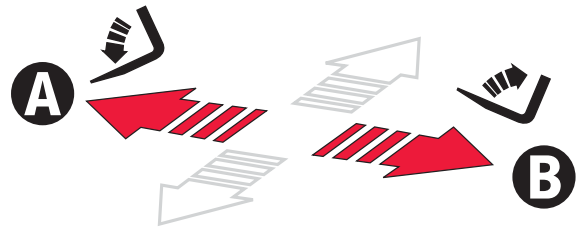

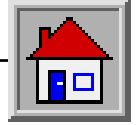

OPERATING INSTRUCTIONS

■ C-3.4.4 Extending/retracting the telescope



Before operating the boom, make sure that nobody is within the working range of the machine.

To extend or retract the boom telescope:

- Smoothly shift the lever to position **D** to extend the boom or to position **C** to retract it.

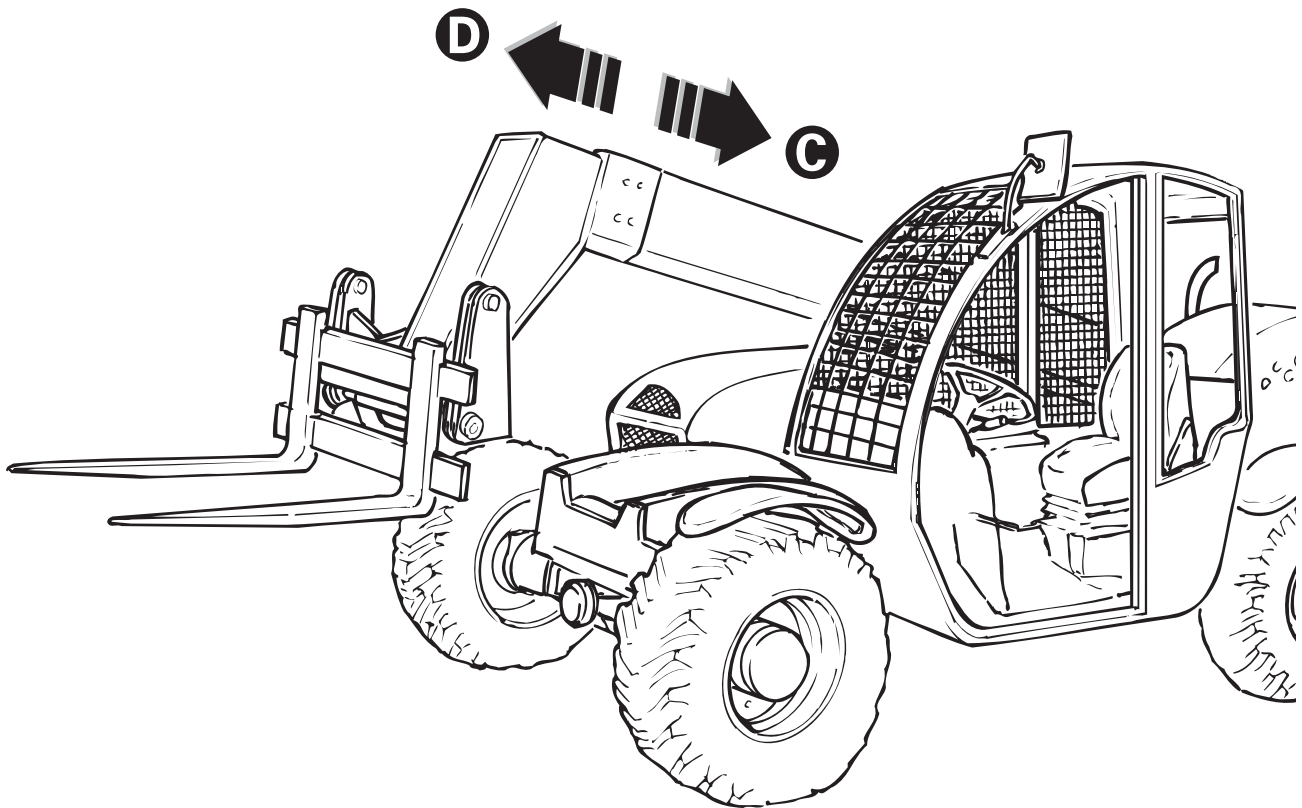
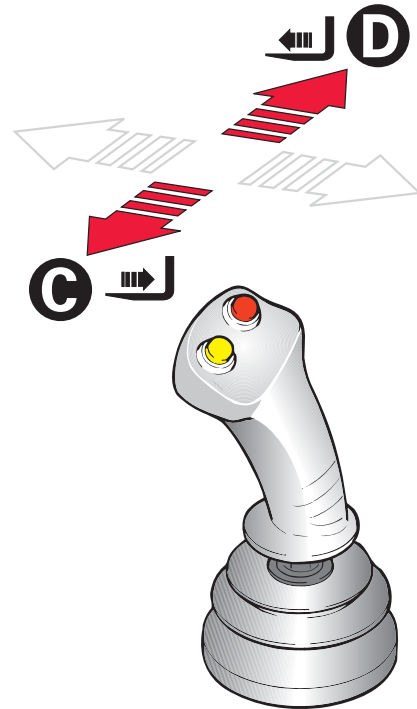

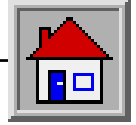

OPERATING INSTRUCTIONS

■ **C-3.4.5 Quick-coupling the attachments**



Before operating the boom, make sure that nobody is within the working range of the machine.

To lock the attachments:

- Press button **3** together with the dashboard enabling button (**12**) and shift the lever to position **B** to unlock the attachment or to position **A** to lock the attachment.

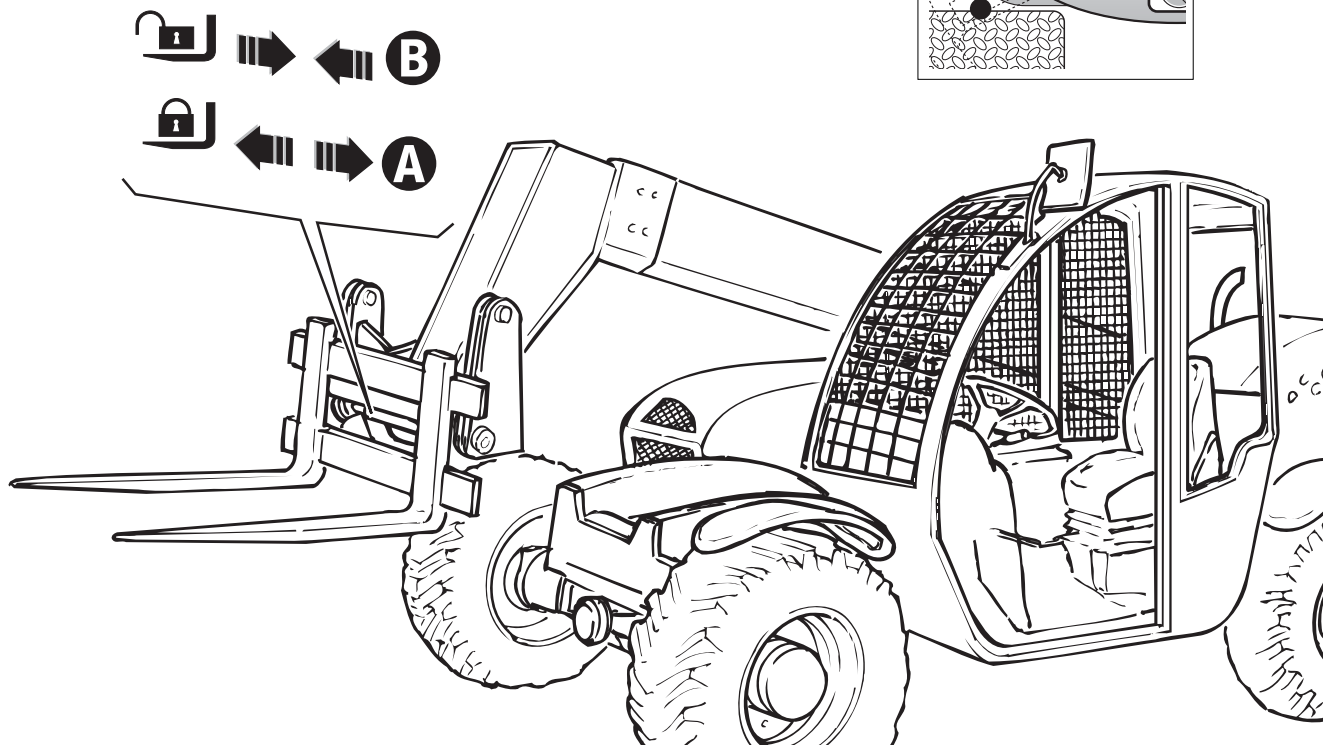
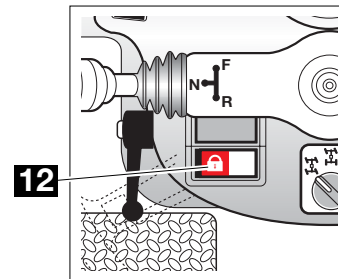
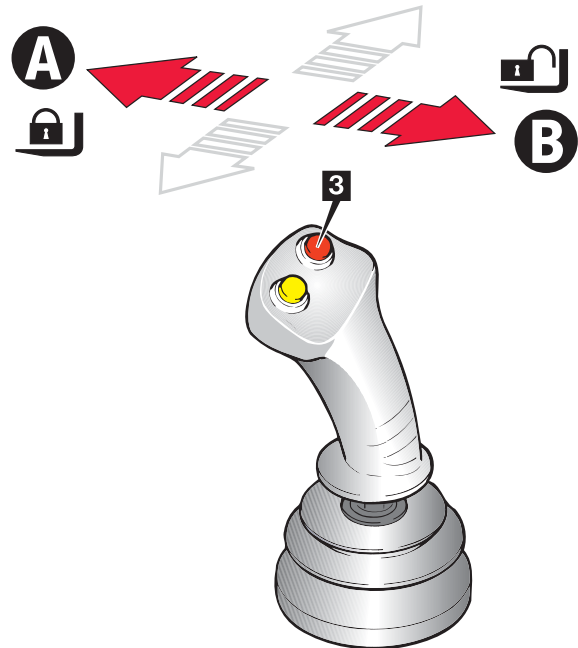

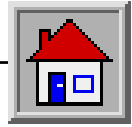

OPERATING INSTRUCTIONS

■ C-4 SETUP

■ C-4.1 BEFORE STARTING THE ENGINE

- To ensure safe conditions to the operators and the bystanders, and a longer life to your machine, perform a walk-around inspection before starting the engine.
- Remove any dirt or rubbish from the cab interior, and especially from pedals and control levers.
- Remove oil, grease and mud from pedals and control levers.
- Make sure that your hands and shoe soles are clean and dry.
- Check the seat belts can be fastened properly.
- Check that lights, indicators, side/tail lights, hazard indicator lights, wipers and horn are in working order.
- Adjust the driving seat so that you can reach all control levers comfortably and fully depress the brake pedal without moving your back from the driving seat.
- Adjust the rear view mirrors to give you a good view close behind the machine when you are correctly seated.
- Check the parking brake is engaged.

■ C-4.1.1 Checks at the machine start-up

Check the efficiency of the safety devices as described in [chap. D-3.15](#), namely:

- machine start control.

■ C-4.2 STARTING THE ENGINE

For the low temperature starting, see paragraph C-4.4.

- Engage the parking brake.
- Put the forward/reverse speed selection lever to neutral.
- Step on the gas pedal.
- To start the engine, turn the ignition switch to position **II**. Release the switch when the engine starts. If the engine does not start within 20 seconds, release the key and wait at least 2 minutes before attempting again.
- After the start-up, let the engine run at idle for some seconds before engaging a gear; this allows for a gradual warm up of the engine oil and a better lubrication.
- In case of engine jump-starting, remove the booster cables (see following chapter).

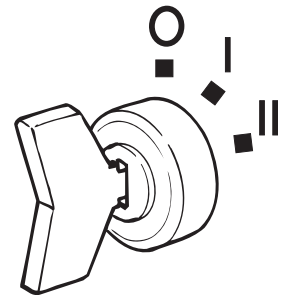

ATTENTION

If the light indicators do not switch off/on when engine is running, immediately stop the machine and find and rectify the fault.

IMPORTANT

Engine cannot be started if the parking brake is not engaged.



DANGER

After the start-up, when leaving the driving place, the engine continues to run. DO NOT LEAVE THE DRIVING PLACE BEFORE HAVING SHUT THE ENGINE DOWN, LOWERED THE BOOM TO THE GROUND AND ENGAGED THE PARKING BRAKE.

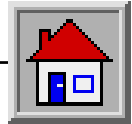

OPERATING INSTRUCTIONS

■ **C-4.3 JUMP-STARTING THE ENGINE**

ATTENTION

Do not start the engine using a quick charge booster to avoid any damage to the electronic boards.

DANGER

When jump-starting the engine through the battery of another machine, make sure that the two vehicles cannot collide to prevent formation of sparks. Batteries give off a flammable gas and sparks may burn it and cause an explosion

Do not smoke when checking the electrolyte level.

Keep any metal object like buckles, watch straps, etc. clear of the battery positive (+) terminal. These elements can short between the terminal and nearby metal work and the operator can get burned.

The booster supply must have the same rated voltage and output of the battery installed on the handler.

To jump-start the engine:

- Turn any users off by the special control levers.
- Put the gear lever to neutral and engage the parking brake.
- Ensure the machine battery **A** is connected to the frame earth, the terminals are well tightened and the electrolyte level is regular.
- Connect the two batteries as shown in the figure. Connect first the positive terminals of the two batteries, then the negative terminal of the booster supply **B** to the machine frame earth.
- If the booster supply is installed on a second vehicle, make sure that the latter does not touch the handler; then start the vehicle and reach an rpm corresponding to 1/4 of full throttle.
- Turn the ignition key and start the handler, then follow the procedure explained in chapter C-4.2 "Starting the engine".

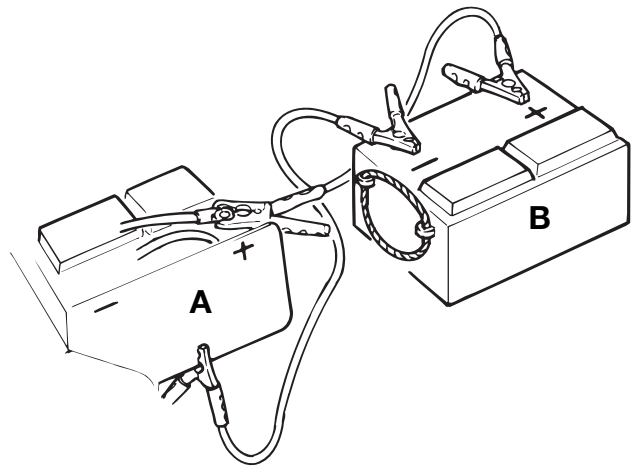

- Disconnect the cables. Remove first the negative terminal from the frame earth, then from the booster supply. Disconnect the positive terminal from the machine battery, then from the booster supply.

DANGER

Use only a 12V battery; other devices like battery chargers, etc. may cause an explosion of the battery or result in damage to the electrical system.

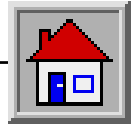

OPERATING INSTRUCTIONS

■ C-4.4 LOW TEMPERATURE STARTING

In case of cold starting, use an oil with a SAE viscosity adequate to the ambient temperature.

Please refer to the DEUTZ engine use and maintenance manual.

The machine is supplied with oil SAE 15W/40.

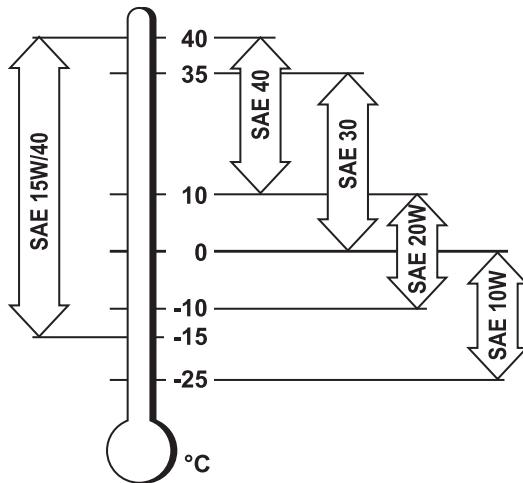

To start the engine from cold, proceed as follows:

- Engage the parking brake.
- Turn the ignition switch to position **I** and wait until the warning light **6** signalling the glow plugs preheating goes off. Step down on the gas pedal and start the engine turning the ignition switch to **II**. Release as soon as the engine starts.
- Let the engine run at idle for a few seconds before putting a gear; this allows for a gradual warm up of the engine oil and a better lubrication.
- In case of engine jump-starting, remove the boosters (see chapter C-4.3).

■ C-4.5 DISCONNECTING THE BATTERY

Before any maintenance or repair work, and especially before welding any components on the machine, remove the cables at the battery.



CAUTION

Before disconnecting the battery, set all switches within the cab to OFF.

To disconnect the battery, disconnect the negative (-) lead from the frame earth first. To connect the battery, connect the positive (+) lead first.

■ C-4.6 STARTING THE MACHINE

When the engine reaches the running temperature, ensure all parts are in transfer position and the gearbox lever is in neutral. Then, proceed as follows:

- Select the required steering mode.
- Select the required gear (forward or reverse).
- Release the parking brake pressing button **18** (the warning light on the pushbutton must be off).
- Slowly step on the gas pedal to start moving off.



CAUTION

Do not operate the forward/reverse gear lever when the machine is running. The machine would reverse the running direction abruptly and you could seriously be injured.

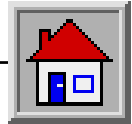

OPERATING INSTRUCTIONS

■ C-4.7 STOPPING AND PARKING THE MACHINE

When possible, stop the machine on a dry, level and solid ground. Then:

- Bring the machine to a smooth stop by easing up the gas pedal and stepping down on the brake pedal.
- Set the forward/back speed lever to neutral position.
- Engage the parking brake pressing button **18** (the warning light on the pushbutton must be on).
- Release the service brake pedal.
- Rest the attachment coupled to the boom flat on the ground.
- Rotate the ignition key to “0” and remove the key.
- Leave the driving cab and lock the cab door.
- Disconnect the battery (see chapter C-4.5).



Always face the machine when getting off the driving cab; make sure that your hands and shoe soles are clean and dry, and hold to the handholds to prevent falls or slips.



Always engage the parking brake after stopping the machine to prevent possible accidental motions of the vehicle.

■ C-5 USING THE HANDLER

This chapter describes some techniques and provides instructions for a safe use of the machine fitted with standard forks. Before using different attachments, thoroughly read the chapter “Optional attachments”.



Before using the machine, inspect the job site and check for possible hazardous conditions. Make sure that there are no holes, moving banks or debris that may cause you to lose the control of the machine.



Pay the greatest attention when working close to electric lines. Check their position and ensure that no part of the machine operates at less than 6 meters from the power lines.



For a safe use of the machine, always check the weight of the loads going to be handled. Always refer to the load charts applied in the cab.

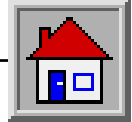

OPERATING INSTRUCTIONS

■ C-5.1 USING THE LOAD CHARTS

On the cab windscreen, there are the load charts that indicate the operator how far a load can be extended. The load chart indicates the payload limits of the machine under safe conditions. To operate under safe conditions, always refer to these charts.



The load charts illustrated in this manual are given only as a mere example. To define the payload limits, refer to the load charts applied in the cab of your machine.



*The load charts applied on the cab windscreen refer to a stationary machine standing on a solid and level ground.
Raise the load some centimetres and check its stability before raising it completely.*

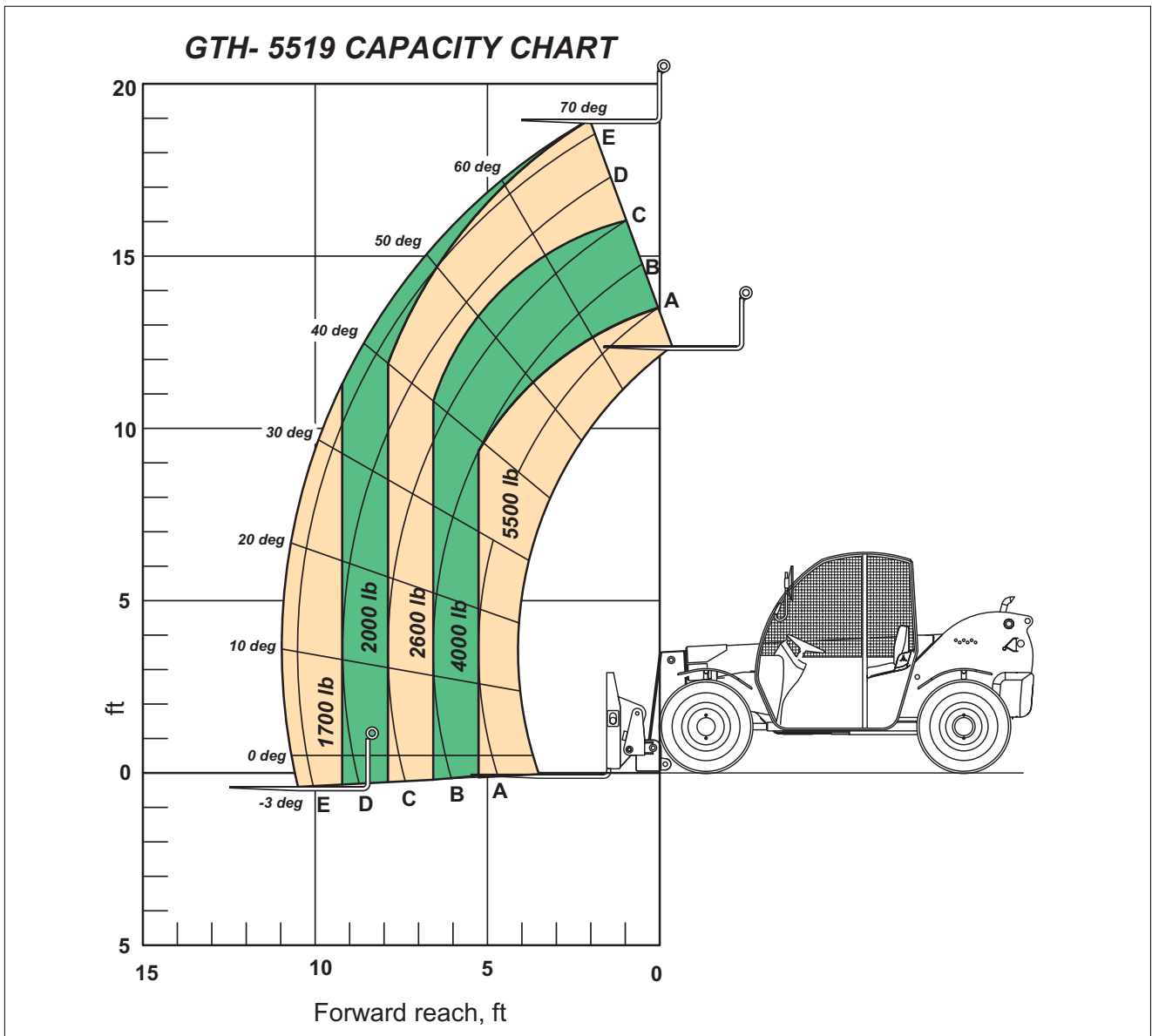

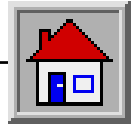

OPERATING INSTRUCTIONS

■ C-5.2 HANDLING LOADS

■ C-5.2.1 Adjusting the floating forks

Forks shall be spaced to suit the load going to be handled. For this purpose:

- Loosen the nut of the locking screws.
- Raise the forks and slide them on the pivot until correct spacing.
- Lock the screws re-tightening the nut.

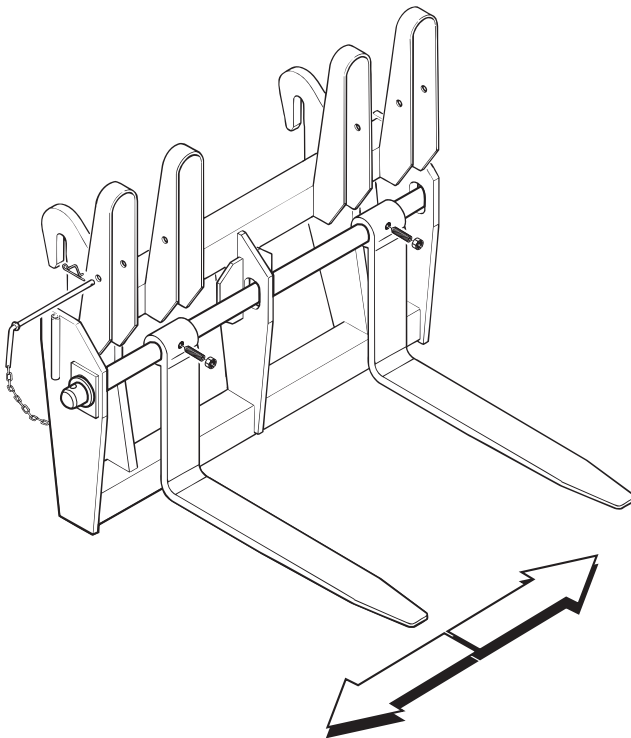

CAUTION

- ***The centre of gravity of the load must always be halfway between the forks.***
- ***Ensure you exactly know the weight of the load before handling it.***
- ***When extending the boom, do not exceed the payload limit.***
- ***Refer to the payload limits given in the load chart applied in the cab or in the quick user's guide.***
- ***Space the forks as wide as possible to suit the load being handled.***

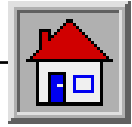

OPERATING INSTRUCTIONS

■ C-5.2.2 Working phases

When forks are correctly spaced, the handler is ready to use.

Work can be subdivided into three different phases: loading, transfer and unloading.

Loading phase

- Approach the load to the handled perpendicularly and check that the machine is level on the inclinometer.
- Insert the forks under the load and raise the load some centimetres.
- Pitch the forks backwards and check the machine stability before handling a load.

Transfer phase

- Do not start or brake abruptly.
- Drive to the unloading point cautiously and keep the load 20÷30 cm from the ground.
- Suit the machine speed to the ground conditions to avoid dangerous jumps, side skids of the vehicle and possible load falls.
- When driving on slopes or ramps, hold the load uphill.



Do not drive on slopes sideways; this wrong manoeuvre is one of the main reasons for accidents due to vehicle overturning.

Unloading phase

- Drive to the unloading point with straight wheels and bring the machine to a smooth stop leaving enough space to operate the boom.
- Put the parking brake and set the transmission to neutral.
- Position the load some centimetres above the desired position and set the forks level.
- Lower the load and make sure it is level.
- Carefully withdraw the forks by operating the boom retraction control and, if necessary, raise or lower the boom as forks come out.
- When the forks are clear of the load, set them to transfer position.

- Release the parking brake and start a new working cycle.



Do not move off when the load is raised 20÷30 cm above the ground. Risk of machine overturning or load fall.

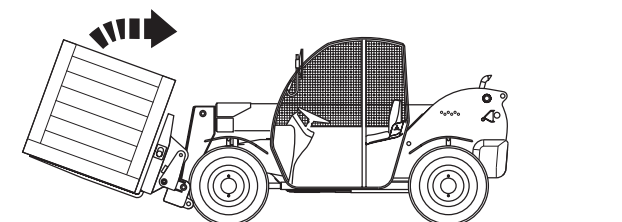
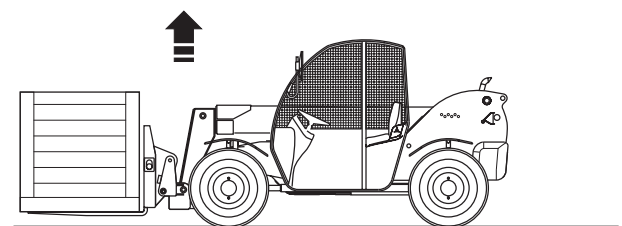
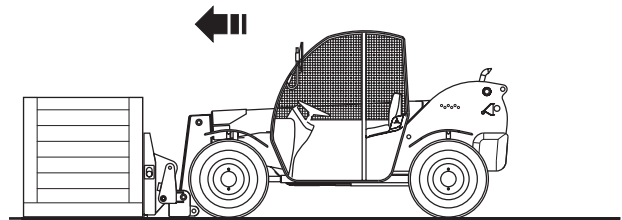
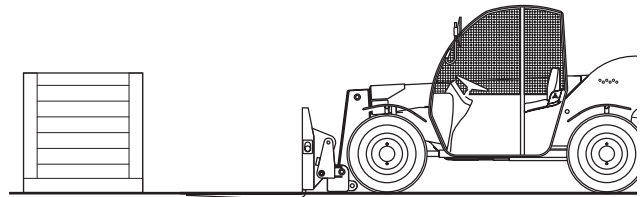

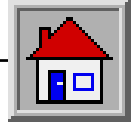

OPERATING INSTRUCTIONS

■ **C-5.3 CHANGING THE ATTACHMENT**

ATTENTION

Use only attachments directly manufactured or recommended by Terexlift and detailed in the "Optional attachments" section.

To change an attachment, operate as follows:

- Drive to the place where you will release the mounted attachment (when possible, a solid and sheltered site).
- Disconnect the quick connectors of the attachment (if any), and connect the hydraulic locking pipes of the attachments to couplings **A**.
- Rest the attachment flat on the ground.
- Pitch the attachment holding frame forward and lower the boom to release the attachment upper lock.
- Move back with the machine (or with the boom) and drive to the new attachment to be coupled.
- Hold the frame pitched forward and hook the upper lock of the new attachment.
- Retract and raise the attachment some centimetres. It will centre automatically on the quick coupling frame.
- Operate the control lever to lock the attachment.

CAUTION

After substitution, visually check the attachment is correctly coupled to the boom, before operating the machine. A wrongly coupled attachment may result in damage to persons or things.

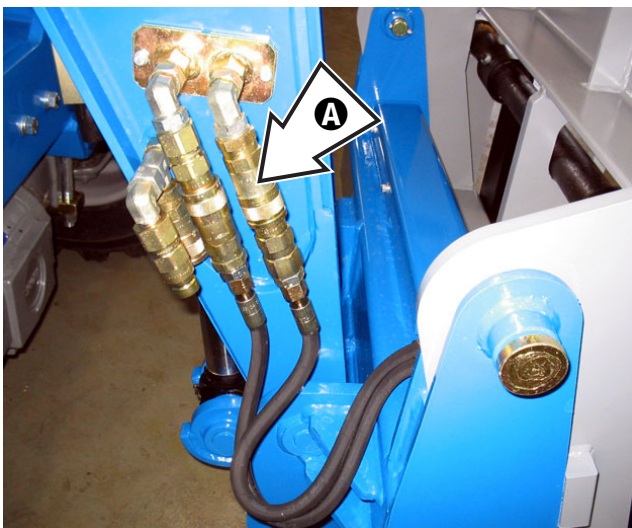
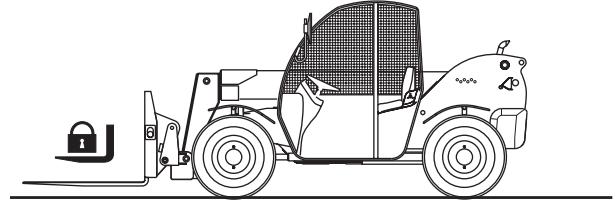
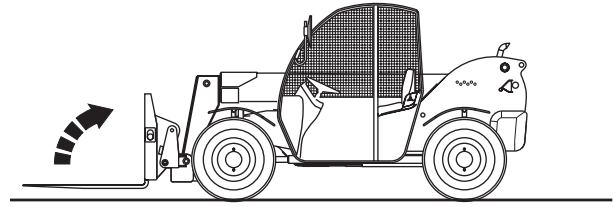
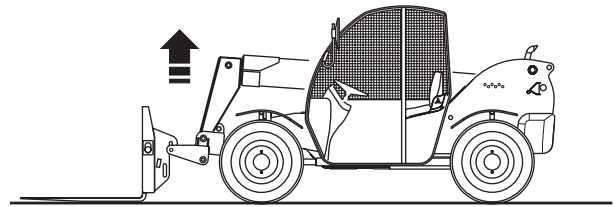
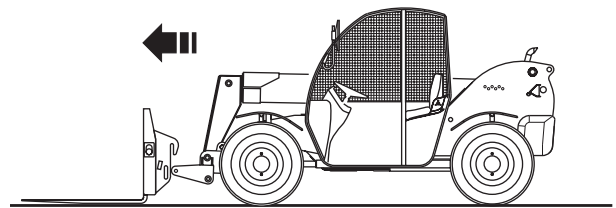
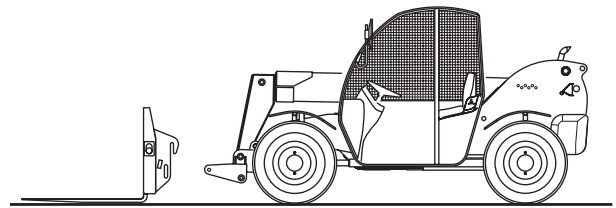

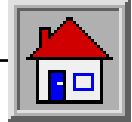

OPERATING INSTRUCTIONS

- Couple the connectors of the attachment, if any, to the quick couplings of the frame.



After the substitution of an attachment or after any coupling operation, visually check the attachment. A wrongly coupled attachment may result in damage to persons or things.

■ C-6 TRANSPORTING THE MACHINE

■ C-6.1 MOVING A DISABLED MACHINE

Tow the machine only when no alternative is possible, since this operation may result in serious damage to the transmission. When possible, repair the machine on site.

When the machine shall absolutely be towed:

- Unlock the negative brake (see chap. C-6.1.1)
- Tow the machine for short distances and at a low speed only.
- Use a rigid drawbar.
- Select the two-wheel steer.
- Set the gearbox lever to neutral.
- When possible, start the engine and use the hydraulic drive and the braking system.
- Raise the front wheels of the machine and remove the Cardan shaft of the transmission.

■ C-6.1.1 Unlocking the negative brake

To unlock the negative brake of a faulty machine, proceed as follows:

- Loosen the two opposite screws **A** located on the front axle in order to remove the washers.
- Remove the horseshoe-shaped washers located under the two screws.
- Re-tighten screws **A** turning alternately the front screw and the rear screw 1/2 turn to unlock the brake.

To relock the negative brake, loosen the screws **A** turning alternately the front screw and the rear screw 1/2 turn, refit the horseshoe washers and re-tighten screws **A**.

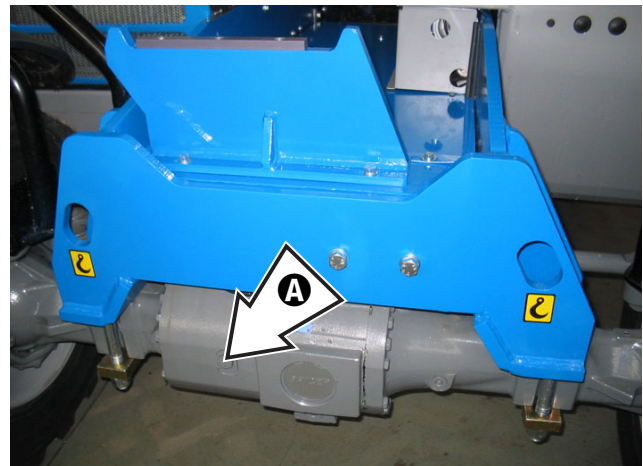

■ C-6.2 ROAD OR SITE TRANSFER

When travelling on public roads, strictly obey the local or national road traffic regulations.

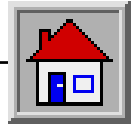

OPERATING INSTRUCTIONS

■ **C-6.3 LIFTING THE MACHINE**

When the machine shall be lifted, use only means having a suitable capacity. The characteristic data are detailed in the relevant chapter of this manual and on the identification plate.

For the machine lifting, anchor the chains to the special links on the machine (marked with the decal below).

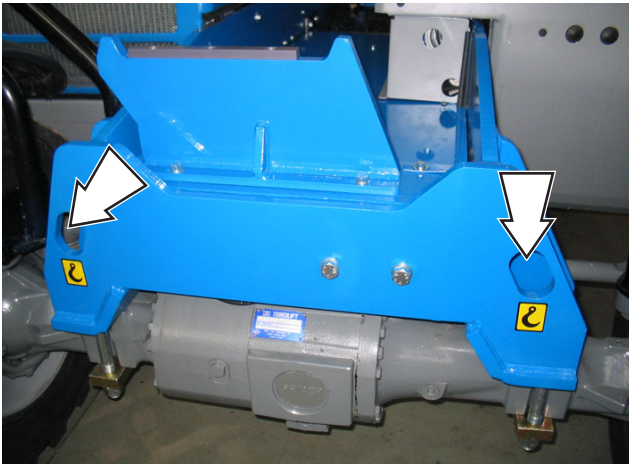

■ **C-6.4 TRANSPORTING THE MACHINE ON OTHER VEHICLES**

To transport the machine on another vehicle, follow the steps below:

- Put chocks at the machine wheels.
- Ensure ramps are correctly positioned.
- Retract the boom to transfer position.
- Carefully drive the machine onto the transporting vehicle.
- Put the parking brake and rest the attachment flat on the vehicle platform.
- Ensure the overall dimensions do not exceed the allowed limits.
- Shut the engine down and close the driving cab of the machine.
- Secure the machine to the vehicle platform by wheel-chocks.
- Anchor the machine to the transporting vehicle with suitable chains.

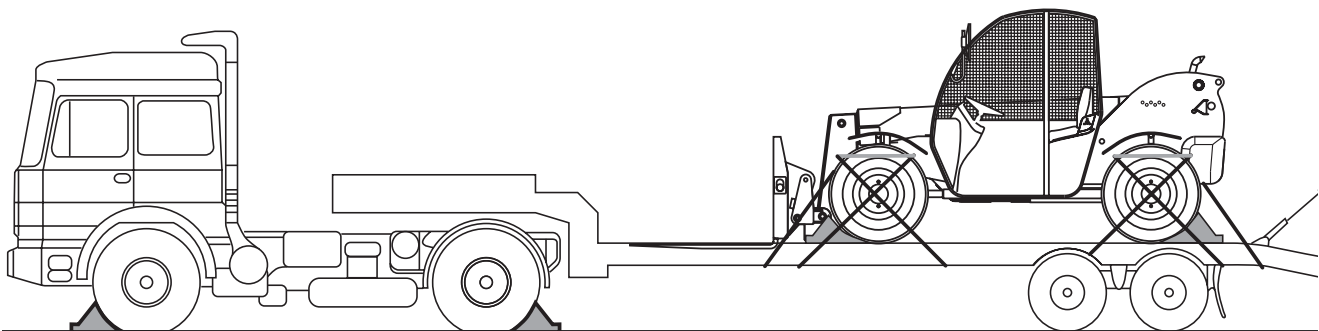

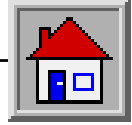
**OPERATING INSTRUCTIONS****■ C-6.5 PARKING AND STORAGE****■ C-6.5.1 Short inactivity**

Always park the machine in a safe way after a working day, a shift and at night.

Take all precautions to prevent damage to those persons who will approach the machine while stationary:

- Park the machine so that it does not hinder other operations.
- Lower the boom fitted with attachment on the ground.
- Remove the key from the ignition switch. Leave the driving cab and lock the cab door.
- Disconnect the battery (see chapter C-4.5).

■ C-6.5.2 Machine storage

In case of extended inactivity of the machine, follow the above precautions. Additionally:

- Wash the machine thoroughly. For a better cleaning, remove grills and protection casings
- Carefully dry all machine parts by blowing some compressed air.
- Lubricate the machine thoroughly.
- Do a walk-around inspection and replace any worn or damaged part.
- Re-paint any worn or damaged part.
- Remove the battery, smear its terminals with vaseline and store it in a dry place. Battery can be used for other purposes. Otherwise, periodically check its charge level.
- Refuel the tank to prevent internal oxidation.
- Store the machine in a sheltered and well-ventilated place.
- Start the engine for about 10 minutes at least once a month.

IMPORTANT

Always remember that the ordinary maintenance must be carried out even during the machine inactivity. Pay particular attention to the fluid levels and to those parts subject to ageing. Before re-starting the machine, carry out an extraordinary maintenance and carefully check all mechanical, hydraulic and electrical components.

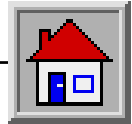

OPERATING INSTRUCTIONS

■ C-6.6 CLEANING AND WASHING THE MACHINE

■ C-6.6.1 Cleaning instructions

Clean the machine in accordance with the following instructions:

- Remove any oil or grease traces with a dry solvent or a volatile mineral alcohol
- Before assembling a new part, remove any protection product (rust-preventer, grease, wax etc.).
- Remove any trace of rust from metal parts with some emery cloth before smearing the part with a protection product (rust-preventer, paint, oil etc.).

■ C-6.6.2 Washing instructions

External washing

Before washing the machine, check that the engine is shut down and the doors and windows are closed. Do not, at any times, use fuel to clean the machine. Use water or some steam. In cold climates, dry the locks after washing or smear them with an antifreeze. Before using the machine again, check its conditions.

Internal washing

Wash the machine interior with some water and a sponge. Do not use water at high pressure. After washing, dry with a clean cloth.

Washing the engine

Before washing the engine, protect the air intake filter to prevent water from entering the circuit.

■ C-6.7 MACHINE DISPOSAL



At the end of the machine life, call in a specialised firm to dispose of it in compliance with the local or national regulations.

■ C-6.7.1 Battery disposal



Used lead-acid batteries cannot be disposed of as normal industrial solid wastes. Because of the presence of harmful substances, they must be collected, eliminated and/or recycled in accordance with the laws of the UE.

In Italy, used or discarded batteries have been classified as "Toxic wastes" in accordance with Presidential decree n. 397 of 09/09/1988 and Law n. 475 O.G. n. 18 of 09/11/1988 because they contain lead and sulphuric acid. Their disposal through recycling must be done only through companies authorised and belonging to the "Consorzio Obbligatorio Batterie Esauste e dei rifiuti piombosi" (Cobat) which collect and dispose of used lead-acid batteries throughout the national territory.

Used batteries must be kept in a dry and confined place. Make sure the battery is dry and the cell plugs are tight. Place a sign on the battery to warn of not using it. If before disposal the battery is left in the open air, it will be necessary to dry, smear the box and the elements with a coat of grease and tighten the plugs. Do not rest the battery on the ground; it is always advisable to rest it on a pallet and cover it. The disposal of batteries shall be as rapid as possible.

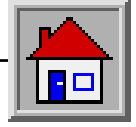

OPERATING INSTRUCTIONS

Intentionally blank page

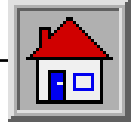

MAINTENANCE

Section D

MAINTENANCE

TABLE OF CONTENTS

D-1	LUBRICANTS - HEALTH AND SAFETY PRECAUTIONS	D-2
D-2	ROUTINE MAINTENANCE	D-3
D-2.1	Oil change schedule	D-4
D-3	MAINTENANCE JOBS	D-5
D-3.1	Disconnecting the battery	D-5
D-3.2	Access to the engine and tanks compartments	D-6
D-3.3	Greasing	D-7
D-3.4	Tyres and wheels	D-8
D-3.5	Brakes	D-9
D-3.5.1	Checking the brake oil level	D-9
D-3.6	Engine air filter	D-10
D-3.7	Cab air filter (only with cabin closed or glass kit installed)	D-11
D-3.8	Engine cooling circuit	D-11
D-3.9	Checking the oil level in the tank	D-12
D-3.10	Changing the oil filter canisters on the intake line	D-13
D-3.10.1	Transmission oil filter	D-13
D-3.10.2	Auxiliary circuits oil filter	D-14
D-3.11	Oil level in the differential gears and the reducer	D-15
D-3.11.1	Front and rear differential gears	D-15
D-3.11.2	Reducer	D-15
D-3.12	Oil level in the (front/rear) wheel reduction gears	D-16
D-3.13	Shafting alignment	D-17
D-3.14	Adjusting the sliding pads of the boom sections	D-18
D-3.15	Checking the safety devices	D-19
D-4	ELECTRICAL SYSTEM	D-21
D-4.1	Battery	D-21
D-4.2	Fuses and relays	D-22
D-5	REFUELLING	D-24
D-5.1	Refuelling	D-24
D-5.2	Product specifications	D-24
D-5.2.1	Engine oil	D-24
D-5.2.2	Lubrication oils and relevant filtering elements	D-24
D-5.2.3	Fuel	D-25
D-5.2.4	Grease	D-25

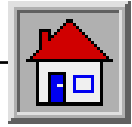

MAINTENANCE

INTRODUCTION

A thorough and regular maintenance keeps the machine in a safe and efficient working condition.

For this reason, it is advisable to wash, grease and service the machine properly, especially after having worked under particular conditions (muddy or dusty environments, heavy operations, etc.).

Always ensure all machine components are in good condition. Check for oil leaks or loosening of guards, and make sure that the safety devices are efficient. In case of defects, find and rectify them before using the machine again.

The maintenance interventions are based on the machine working hours. Regularly check the hour-meter and keep it in good condition to define the maintenance intervals correctly.

Not respecting the ordinary maintenance schedule of this manual automatically voids GENIE warranty.

IMPORTANT

For the engine maintenance, please refer to the specific Operator handbook supplied with the machine.

D-1 LUBRICANTS - HEALTH AND SAFETY PRECAUTIONS

Health

A prolonged skin contact with oil can cause irritation. Use rubber gloves and protective goggles. After handling oil, carefully wash your hands with soap and water.

Storage

Always keep lubricants in a closed place, out of the children's reach. Never store lubricants on the open air and without a label indicating their contents.

Disposal

New or exhausted oil is always polluting! Never drain oil on the ground. Store new oil in a suitable warehouse. Pour exhausted oil into cans and deliver them to specialised firms for disposal.

Oil leaks

In case of accidental oil leaks, cover with sand or type-approved granulate. Then scrape off and dispose of it as chemical waste.

First aid

Eyes : In case of accidental contact with the eyes, wash with fresh water. If the irritation persists, seek medical advice.

Intake : In case of oil intake, do not induce vomiting, but seek medical advice.

Skin : In case of a prolonged contact, wash with soap and water

Fire

In case of fire, use carbon dioxide, dry chemical or foam extinguishers. Do not use water.

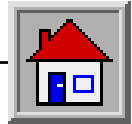

MAINTENANCE

D-2 ROUTINE MAINTENANCE

A wrong or neglected maintenance can result in possible risks for both operator and bystanders. Make sure maintenance and lubrication are carried out according to the manufacturer's instructions to keep the machine safe and efficient.

The maintenance interventions are based on the machine working hours. Regularly check the hour-meter and keep it in good conditions to define the maintenance intervals correctly. Make sure any defect detected during the maintenance is promptly rectified before using the machine.

ATTENTION

All "▲" marked operations must be carried out by a skilled technician.

During the first 10 working hours

- 1 Check the oil level within reduction gears, power divider and differential gears
- 2 Regularly check the tightening of the wheel bolts
- 3 Check the tightening of all bolts and nuts
- 4 Check the couplings for oil leaks

Within the first 50 working hours

- 1 Change the oil for the first time

Every 10 working hours or daily

- 1 Check the engine oil level
- 2 Clean the air suction filter
- 3 Clean the radiator, if necessary
- 4 Check the hydraulic oil level in the tank
- 5 Check the greasing of the boom section pads
- 6 Grease the attachment holding frame
- 7 Grease all joints of the boom, the rear axle shaft joint, the transmission shafts, the front and rear axles and any equipment of the machine
- 8 Check the efficiency of the lighting electric system
- 9 Check the efficiency of braking system and parking brake
- 10 Check the efficiency of the steering selection system
- 11 Check the efficiency of the fork balancing system.
- 12 Make sure the safety devices installed are in efficient working order - see procedure in [chap. D-3.14](#).

Every 50 working hours or weekly

Jobs to be done in addition to those above

- 1 Check the tension of the alternator belt
- 2 Check the tyre inflation
- 3 Check the tightening of the wheel nuts
- 4 Check the tightening of the Cardan shaft screws

Every 250 working hours or monthly

Jobs to be done in addition to those above

- 1 Change the engine oil and relevant filter
- 2 Check the oil level in the front and rear differential gears and the reducer
- 3 Check the oil level in the four wheel reduction gears
- 4 Check the condition of the canister of the engine air filter; renew the canister if necessary
- 5 Check the clamping of the cableheads to the battery terminals
- 6 Check the air suction hose between engine and filter
- 7 Check the cylinder chromium-plated rods
- 8 Check the hydraulic lines are not worn because of rubbing against the frame or other mechanical components
- 9 Check the electric cables do not rub against the frame or other mechanical components
- 10 ▲ Check the wear of the sliding pads of the boom sections
- 11 ▲ Adjust the play of the sliding pads of the boom sections
- 12 Remove any grease from the boom, then re-grease the sliding parts of the boom sections
- 13 Check the level of the battery electrolyte

Every 3 working months

- 1 Check the efficiency of the block valves - see [chap. D-3.14](#).

Every 500 working hours or every six months

Jobs to be done in addition to those above.

- 1 Visually check the smoke quantity evacuated from the engine exhaust
- 2 Check the tightening of the engine fixing screws
- 3 Check the tightening of the cab fixing screws
- 4 Check the backlash between pins and bushings in all joints
- 5 Change the hydraulic oil filter of the transmission
- 6 Change the hydraulic oil filter in the tank

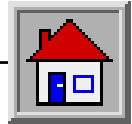

MAINTENANCE

- 7 Have the hydraulic system checked by a skilled technician
- 8 Change the main cartridge of the engine air filter
- 9 Clean or replace, if necessary, the air filter in the cab

Every 1000 working hours or yearly

Jobs to be done in addition to those above

- 1 Change the oil in the front and rear differential units and in the power divider
- 2 Change the oil in the four wheel reduction gears
- 3 Change the hydraulic oil

■ D-2.1 OIL CHANGE SCHEDULE

	Job	operating hours*	service interval*	Oil type
Engine	Oil level check	10	daily	SHELL RIMULA 15W-40
	First change	50	-	
	Subsequent changes	250	monthly	
Axles and power divider	Oil level check	250	monthly	FUCHS TITAN GEAR LS 85 W-90
	First change	-	-	API GL-5 LS / GL-5
	Subsequent changes	1000	yearly	
Hydraulic oil	Oil level check	250	monthly	SHELL TELLUS T 46
	Subsequent changes	1000	yearly	DENISON HF-1, DIN 51524 part 3 Cat. HV

* whichever occurs first

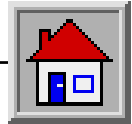

MAINTENANCE

D-3 MAINTENANCE JOBS



All maintenance interventions must be carried out with engine stopped, parking brake engaged, working attachments flat on the ground and gear lever in neutral.



When raising a component for maintenance purposes, secure it in a safe way before any maintenance intervention.



*Any intervention on the hydraulic circuit must be carried out by skilled personnel.
The hydraulic circuit of this machine is fitted with pressure accumulators. You and others could be seriously injured if accumulators are not completely depressurised.
To depressurise the accumulators, just steer the machine wheels some times with engine shut down until noticing a gradual binding of the handwheel.*



Before any operation on hydraulic lines or components, make sure there is no residual pressure. For this purpose, stop the engine, engage the parking brake and operate the control levers of the distributors in both working directions (alternately) to depressurise the hydraulic circuit.



*High pressure lines must be replaced by qualified personnel only.
Any foreign matters entering the closed circuit may result in a sudden deterioration of the transmission.*



The qualified staff charged with the maintenance of the hydraulic circuit must clean all areas around with care before any intervention.



The handling and disposing of used oils can be ruled by local or national regulations. Address to authorised centres.

D-3.1 DISCONNECTING THE BATTERY

Before any maintenance or repair work, and especially before welding any components on the machine, remove the cables at the battery.



*Before disconnecting the battery, set all switches within the cab to OFF.
To disconnect the battery, disconnect the negative (-) lead from the frame earth first. To connect the battery, connect the positive (+) lead first.*

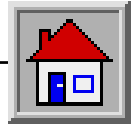

MAINTENANCE

■ **D-3.2 ACCESS TO THE ENGINE AND TANKS COMPARTMENTS**

■ **Engine compartment**

For any operation within the engine compartment, open the protection bonnet. Hood is equipped with lock & key and a supporting rod that holds it in position.

From the engine compartment, you get access to:

- Thermal engine
- Engine air filter **C**
- Hydraulic oil tank plug
- Radiator fluid compensation cup
- Battery

To get access to the engine compartment:

- Shut the engine down and put the parking brake.
- Unlock the bonnet lock **A**
- Lift the bonnet using the special handle **B** until it latches in the gas spring.
- To close the bonnet: press on the green locking device **D** on the gas spring and lower the bonnet.

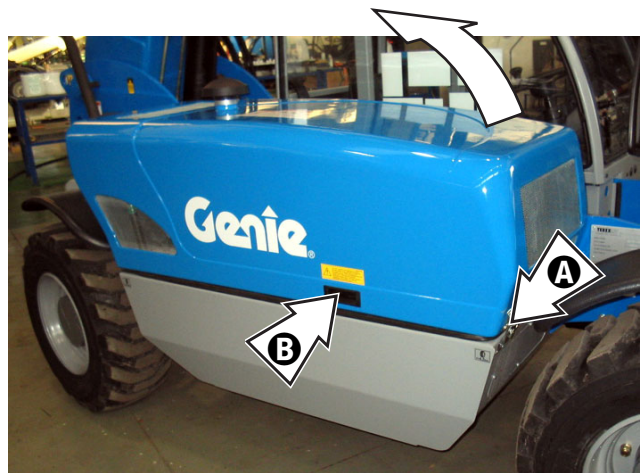

DANGER

Take all precautions when approaching the engine compartment. Some parts of the engine may be very hot. Always use protective gloves.



■ **Diesel fuel tank compartment**

To gain access to the fuel tank, open the rear cover of the machine **E** as follows:

- Shut the engine down and put the parking brake.
- Fully raise the cover by means of the special handle.

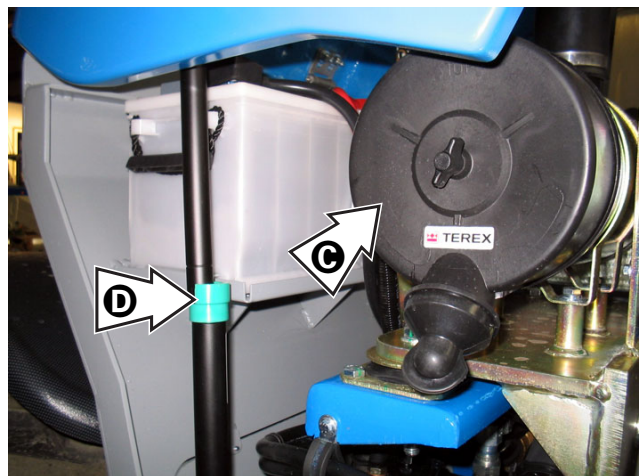
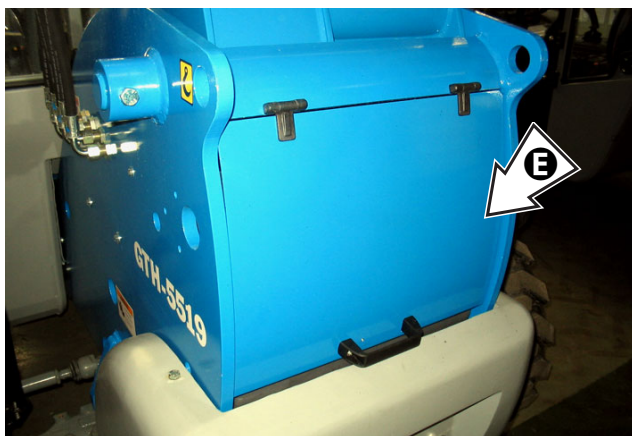

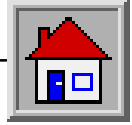

MAINTENANCE

■ **D-3.3 GREASING**

ATTENTION

Before injecting grease into the greasers, thoroughly clean them to avoid that mud, dust or other matters can mix with the lubricant and reduce or annihilate the lubrication effect.



Remove any old grease with a degreaser from the telescopes before smearing them with new grease.

Regularly grease the machine to grant it efficient conditions and a long life.

By means of a pump, inject grease into the special greasers.

As the fresh grease comes out, stop the operation.

The greasing points are shown in the following figures:

- the symbol  represents the points to be greased by a pump
- the symbol  represents the points to be greased by a brush.

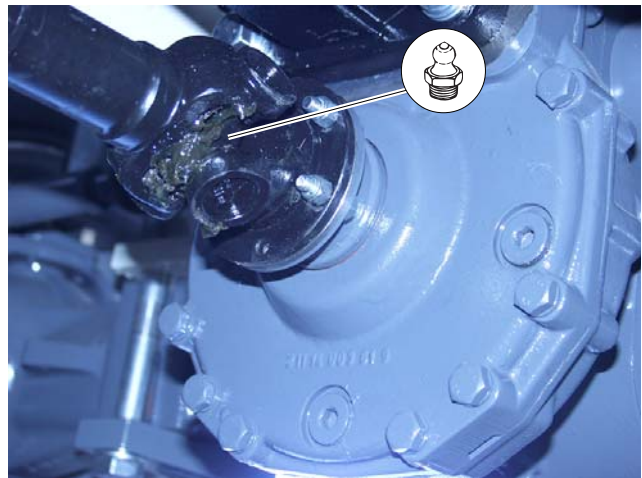
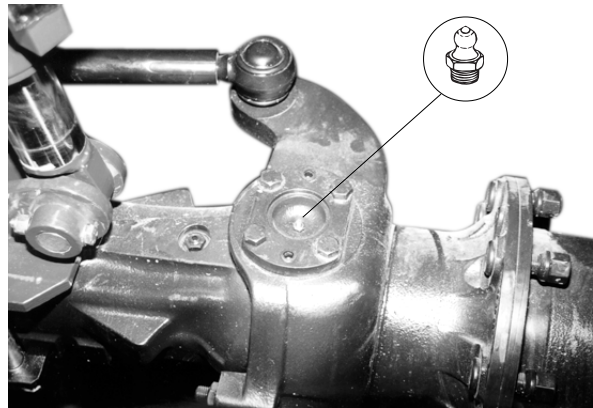

 **SERVICE INTERVAL**

Running-in _____ None

Ordinary _____ **Every 10 hours**

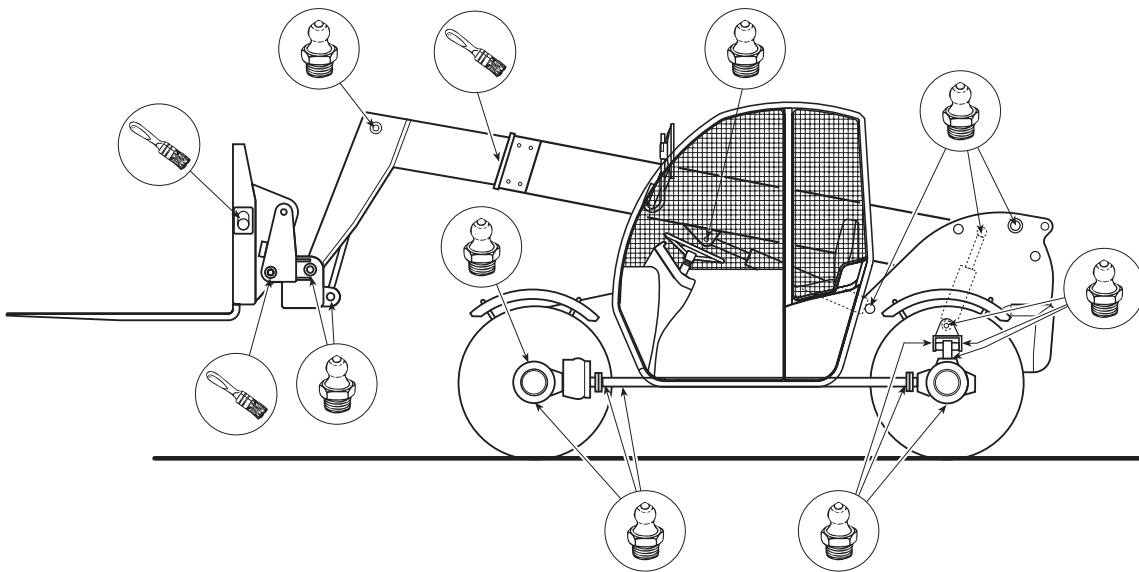

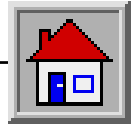

MAINTENANCE

■ **D-3.4 TYRES AND WHEELS**



Over-inflated or overheated tyres can burst. Do not flame-cut or weld the wheel rims. For any repair work, call in a qualified technician.

YES

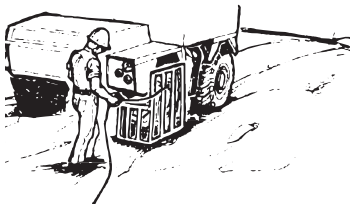

NO

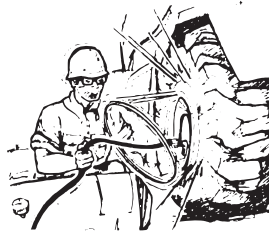

For the tyre inflation or substitution, please refer to the table below:

		GTH-5519
Dimensions		12-16.5 EM14
Load index		pr 10
Rim		9.75x16
Wheel disc		8 holes DIN 70361
Pressure	bar	4.5
	Psi	65

On new machines, and when a wheel has been disassembled or replaced, check the nut torque of the wheels every 2 hours until they stay correct.



Always use tyres having the dimensions indicated in the vehicle registration card.

SERVICE INTERVAL

Running-in _____ **Within the first 10 hours**

Ordinary _____ **Every 250 hours**

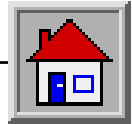

MAINTENANCE

D-3.5 BRAKES

- For any intervention on the braking system (adjustment and/or substitution of the brake discs) call in a specialised technician.

The malfunctioning of the braking system may depend on the presence of air within the hydraulic circuit.

The braking system has two bleeding valves: valve **B** for the service brake circuit and valve **C** for the negative parking brake circuit.

To bleed the circuit of the service brake:

- Make sure that the oil is level within the feeding tank **A**.
- Step on the brake pedal repeatedly.
- Slowly unscrew valve **B** and re-close it as soon as oil mixed with air bubbles comes out.
- Repeat the operation until bubble-free oil comes out.
- Bleed from both sides of the machine.

To bleed the circuit of the negative parking brake:

- Press the parking brake button **D**. As soon as the light indicator on the button goes off, start bleeding through valve **C** until air-free oil comes out.

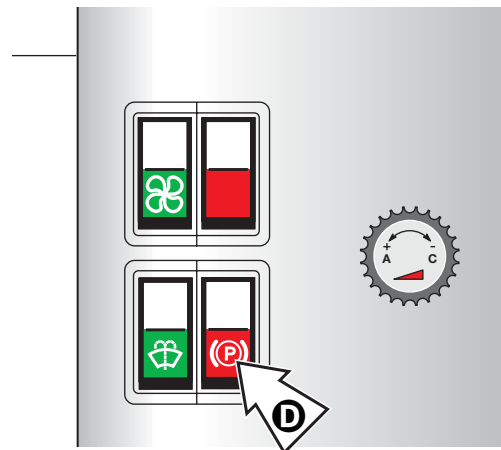
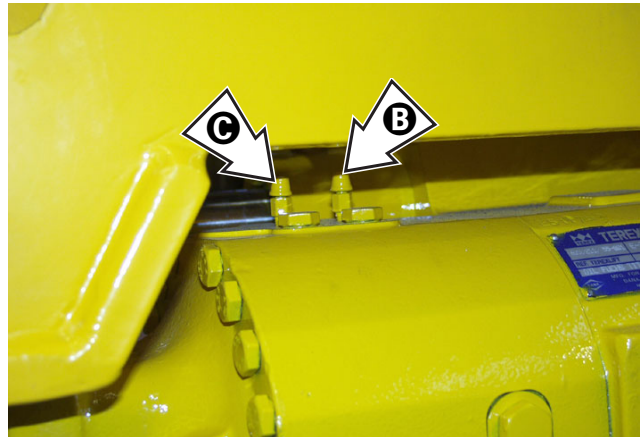

D-3.5.1 Checking the brake oil level

The oil within the braking circuit must be at about 2 cm from the tank plug **A**.

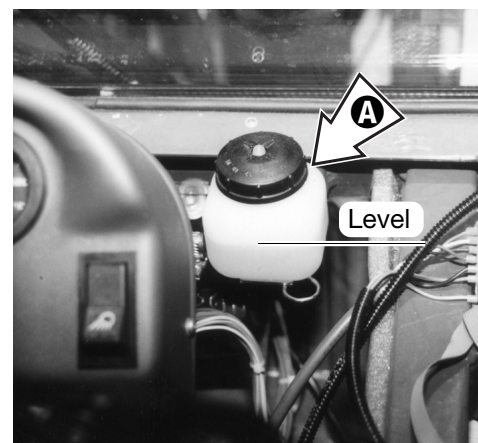

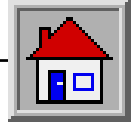

MAINTENANCE

■ D-3.6 ENGINE AIR FILTER

Clean the engine air filter every 10 hours; replace the filtering element, if necessary.

- 1 Cleaning and changing the external element:
 - Stop the engine and engage the parking brake.
 - Unscrew wingnut **A** and remove cover **B**.
 - Unscrew wingnut **C** and remove the outer element **D**.
 - Clean the filter bowl.
 - Clean the cartridge by beating it some times on the ground paying attention not to damage the filtering element.
Do not dry-clean the filtering element.
 - Check for cracks in the filtering element by introducing a lamp inside.
 - Smear the seal with grease, then refit the element.
 - Tighten wingnut **C**, close cover **B** and tighten with wingnut **A**.

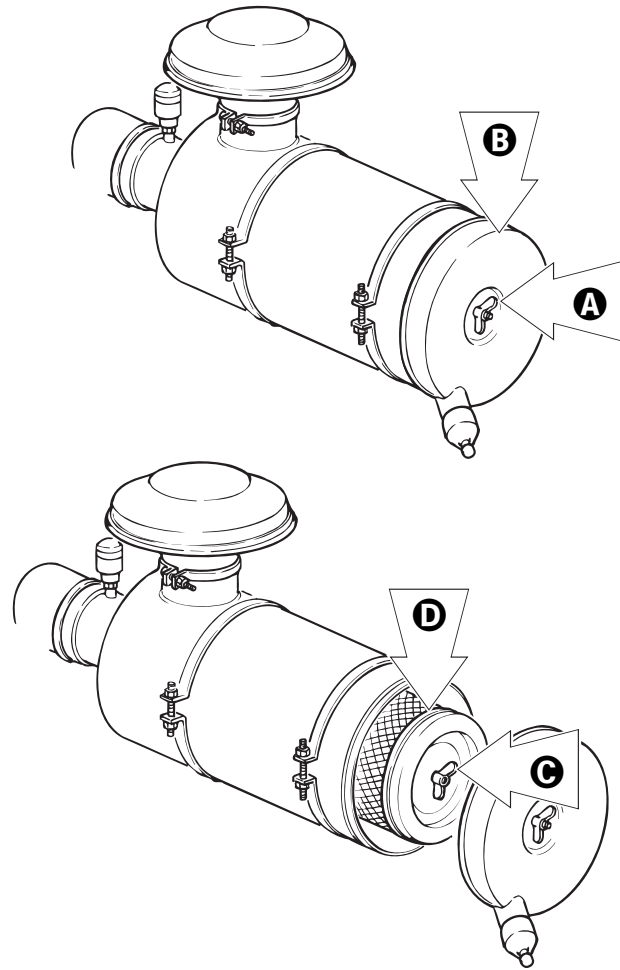

ATTENTION

As soon as the warning lamp on the cab dashboard switches on, replace the outer element.

SERVICE INTERVAL

Running-in _____ **None**

Cleaning _____ **Every 10 hours**

Filtering element substitution **Every 500 hours**

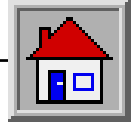

MAINTENANCE

■ D-3.7 CAB AIR FILTER (ONLY WITH CABIN CLOSED OR GLASS KIT INSTALLED)

Every six months clean the air filter in the cab. Replace the cartridge if the filtering cloth is damaged.

1 Cleaning and changing the cartridge:

- Shut the engine down and engage the parking brake.
- Pull out the filter **A** located to the left of the driving place.
- Clean the filter bowl.
- Clean the filter cartridge and replace in case of damage.

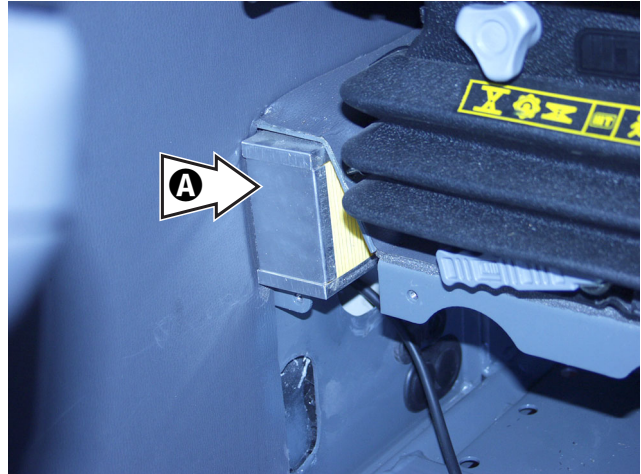

ATTENTION

Do not, at any times, dry-clean the filters. Use some water and/or solvent.

■ D-3.8 ENGINE COOLING CIRCUIT

The cooling radiator is lubricated with the engine oil and does not need any maintenance.

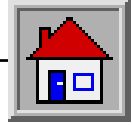

MAINTENANCE

■ D-3.9 CHECKING THE OIL LEVEL IN THE TANK

 **DANGER**

Fine jets of hydraulic oil under pressure can penetrate the skin. Do not use your fingers, but a piece of cardboard to detect oil leaks.

Check the hydraulic oil level (visually) through the special level **B** fitted into the tank.

When necessary, add new oil through filler **A**.

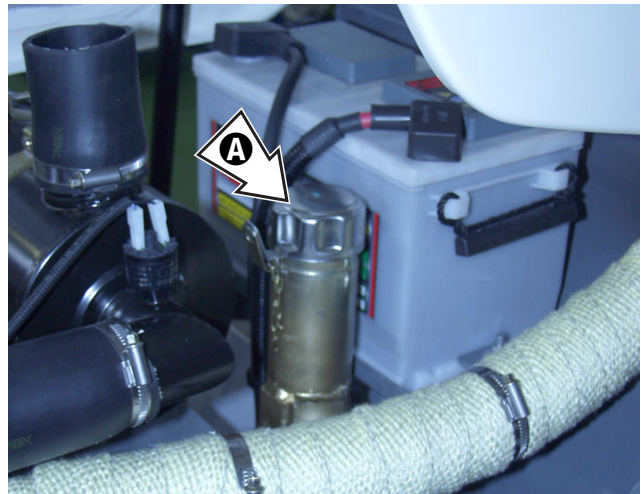

 **CAUTION**

Check the oil level with handler set to transfer position (lowered boom and retracted telescopic element).



 **SERVICE INTERVAL**

Running-in _____ **Within the first 10 hours**

Ordinary _____ **Every 50 hours**

If oil must be changed, proceed as follows:

- 1 Stop the machine on a level ground and make sure the parking brake is engaged.
- 2 Release the pressure from the hydraulic circuit.
- 3 Place a container of suitable size under the drain plug, placed in the lower part of the reservoir, and collect any oil leaks.
- 4 Remove the drain plug and allow oil to flow out into the container.
- 5 Remove the inspection cover of tank **C**.
- 6 Carefully wash the tank with Diesel oil and blow a jet of compressed air.
- 7 Refit the drain plug and the inspection cover.
- 8 Add new oil by making sure that it matches the recommended type indicated in paragraph D-5.2.2. until it is level with **B**.

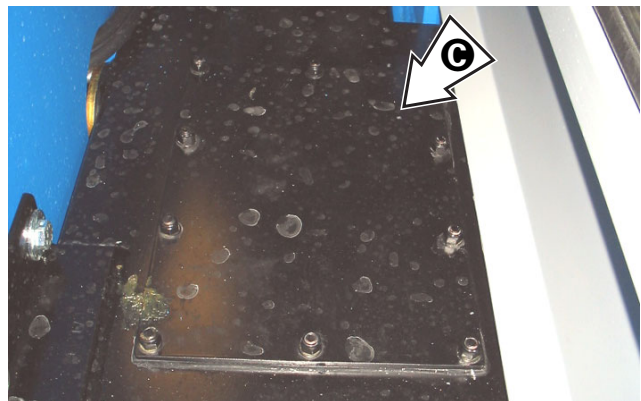

 **SERVICE INTERVAL**

Running-in _____ **None**

Ordinary _____ **Every 1000 hours**

 **PROTECT THE ENVIRONMENT**

The handling and disposing of used oils can be ruled by local or national regulations. Address to authorised centres.

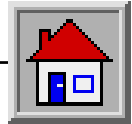

MAINTENANCE

■ D-3.10 CHANGING THE OIL FILTER CANISTERS ON THE INTAKE LINE

■ D-3.10.1 Transmission oil filter

Every 50 hours, check the clogging degree of the filtering element using the vacuumeter **A**.

The indexed scale of the vacuumeter is divided into 3 areas:

- 1 - Green area:** Normal condition
- 2 - Yellow area:** Replace the filter as soon as possible
- 3 - Red area:** Shut the engine down to prevent damage to the hydraulic system. Change the filter and/or check for the fault reasons.

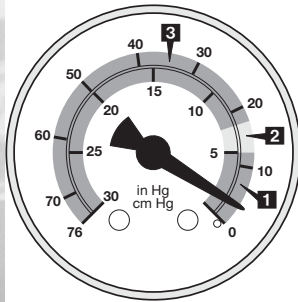
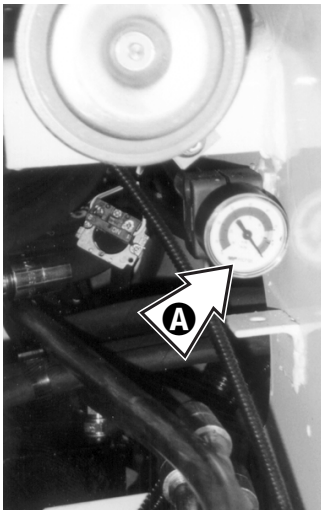
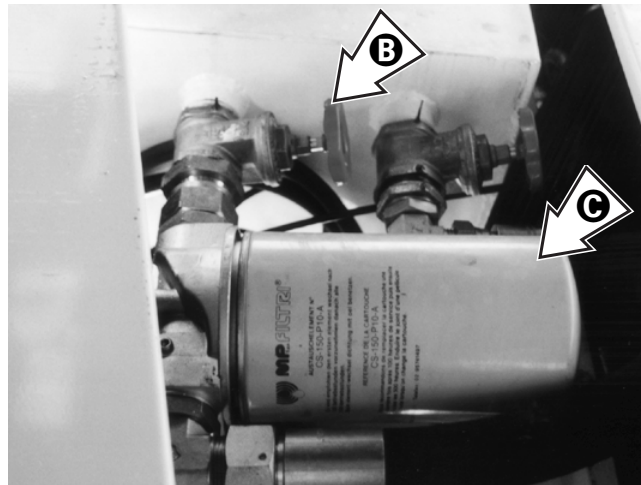

IMPORTANT

Hydraulic oil filter cartridges cannot be cleaned or washed and refitted.

They must be replaced with new ones of the type recommended by the manufacturer (see par. D-5.2.2).

PROTECT THE ENVIRONMENT

The handling and disposing of used oils can be ruled by local or national regulations. Address to authorised centres.

To change the hydraulic oil filter element on the suction line, proceed as follows:

- 1 Stop the machine on a level ground and engage the parking brake.
- 2 Place a container of suitable size under the filter to collect any oil leaks, then close cock **B**.
- 3 Remove the filtering element **C** using a wrench.
- 4 Change the filtering element, then, before fitting a new one, thoroughly clean and grease both seat and gasket.
- 5 Hand-tighten and re-open cock **B**.

IMPORTANT

When changing the oil, drain it when it is still hot and the polluting substances are in suspension.

 **SERVICE INTERVAL**

Running-in _____ None

Ordinary _____ **Every 500 hours**

When the dashboard indicator switches on

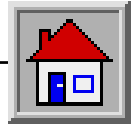

MAINTENANCE

■ **D-3.10.2 Auxiliary circuits oil filter**

To change the hydraulic oil filter cartridge of the service circuits, proceed as follows:

- 1 Stop the machine on a level ground and engage the parking brake.
- 2 Remove the inspection hatch **D** and unscrew the oil filter fitted inside the tank.
- 3 Check the tank is clean, then fit a new filtering element and refit the inspection hatch.
- 4 Check the oil level within the tank. Add new oil, if necessary.

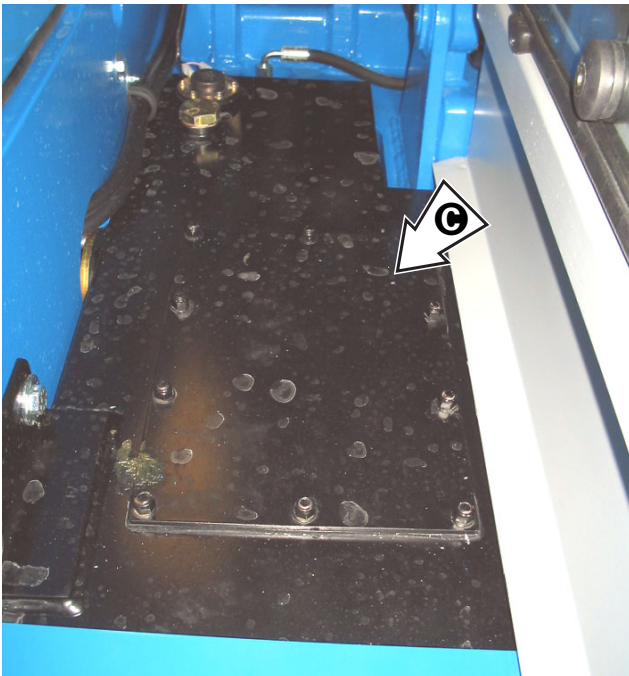

	SERVICE INTERVAL
Running-in _____	None
Ordinary _____	Every 500 hours

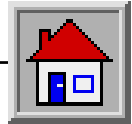

MAINTENANCE

D-3.11 OIL LEVEL IN THE DIFFERENTIAL GEARS AND THE REDUCER

D-3.11.1 Front and differential gears

To check the oil level in the front and rear differential gears:

- Stop the machine on a level ground and engage the parking brake.
- Loosen level plug **A** and check if oil is level with the hole.
- If necessary, add new oil through the hole of the level plug until it comes out.
- Refit and tighten plug **A**.

For the oil change:

- Place a container of suitable size under drain plug **B**.
- Loosen the drain plug and the level plug **A** and allow oil to flow out from the differential gears.
- Refit and tighten drain plug **B**.
- Add new oil through plug **A** until it is level with the hole.
- Refit and tighten level/filler plug.

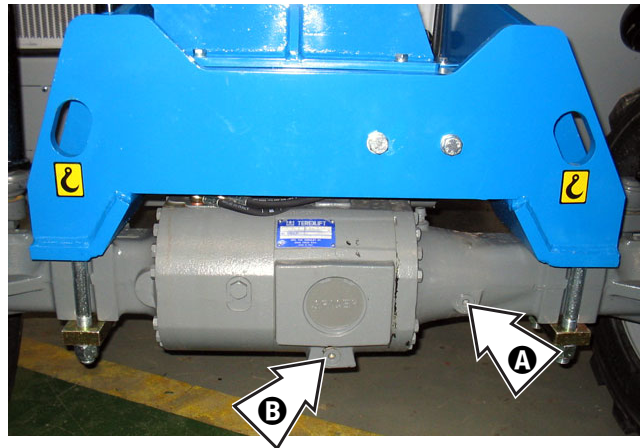

 **SERVICE INTERVAL**

Running-in _____ **Within the first 10 hours**

Ordinary _____ **Every 250 hours**

D-3.11.2 Reducer

To check the oil level in the reducer

- Stop the machine on a level ground and engage the parking brake.
- Loosen level plug **C** and check if oil is level with the hole.
- If necessary, add new oil through the hole of the level plug until it comes out.
- Refit and tighten plug **C**.

For the oil change:

- Place a container of suitable size under drain plug **D**.
- Loosen the drain plug **D** and the level plug **C** and allow oil to flow out from the reduction gear.
- Refit and tighten drain plug **D**.
- Add new oil through plug **C** until it is level with the hole.
- Refit and tighten plug **C**.

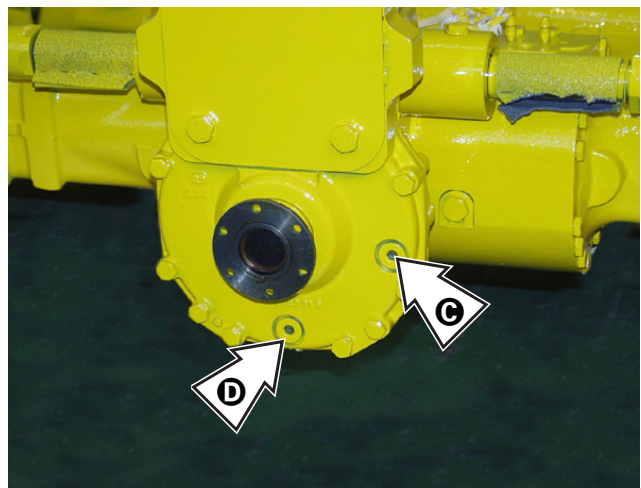

 **SERVICE INTERVAL**

Running-in _____ **Within the first 10 hours**

Ordinary _____ **Every 250 hours**

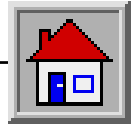

MAINTENANCE

■ D-3.12 OIL LEVEL IN THE (front/rear) WHEEL REDUCTION GEARS

To check the oil level within the wheel reduction gears:

- Stop the machine on a level ground and ensure the parking brake is engaged and plug **A** finds on the horizontal axis.
- Clean the plug all around, then remove it and check if oil is level with the hole.
- If necessary, add new oil through hole **A** until it is level.
- Refit the plug.

For the oil change:

- Stop the machine and ensure the plug is oriented along the vertical axis.
- Place a container of suitable size under the reduction gear plug.
- Unscrew plug **A** and drain any oil from the reduction gear.
- Rotate the wheel by 90° until the plug finds again on the horizontal axis.
- Add new oil through hole **A**.
- Refit and tighten plug **A**.



The handling and disposing of used oils can be ruled by local or national regulations. Address to authorised centres.



When changing the oil, drain it when it is still hot and the polluting substances are in suspension.

 **SERVICE INTERVAL**

Running-in _____ **Within the first 10 hours**

Ordinary _____ **Every 250 hours**

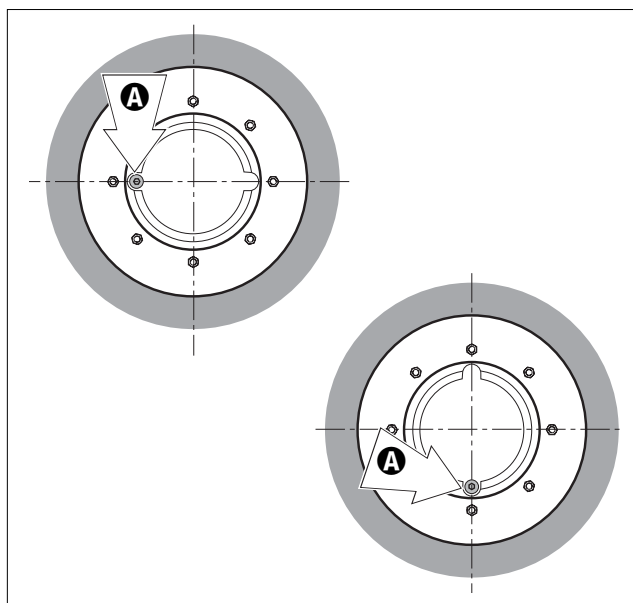

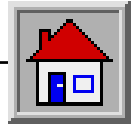

MAINTENANCE

D-3.13 SHAFTING ALIGNMENT

During operation, the alignment of the front and rear axles of the machine can be subject to variations. This can depend on an oil blow-by from the steering control circuit, or on a steering of both axles when front and rear wheels are not perfectly aligned.

To fix this problem, rather than checking the alignment visually, follow the procedure below:

- 1) Move to a solid and level ground
- 2) Set the steering selection switch **13** to “**four-wheel steer**” (pos. **2**)
- 3) Rotate the steering up to its stop (either to the right or to the left)
- 4) Set the steering selection switch to “**two-wheel steer**” (pos. **0**)
- 5) Rotate the steering up to its stop (turn in the same direction as above)
- 6) Reset the steering selection switch to “**four-wheel steer**” (pos. **2**)
- 7) Rotate the steering (to the side opposite to point **3**) so that the rear axle reaches its stop
- 8) Reset the steering selection switch to “**two-wheel steer**” (pos. **0**)
- 9) Rotate the steering (to the same side as in point **7**) so that the front axle reaches its stop
- 10) Reset the steering selection switch to “**four-wheel steer**” (pos. **2**)

Now the wheels should be re-aligned.

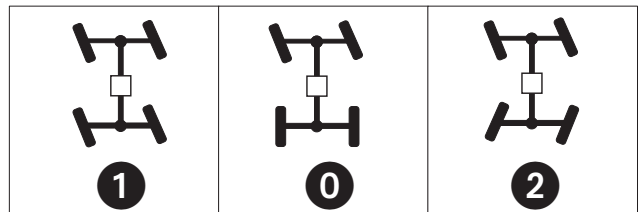
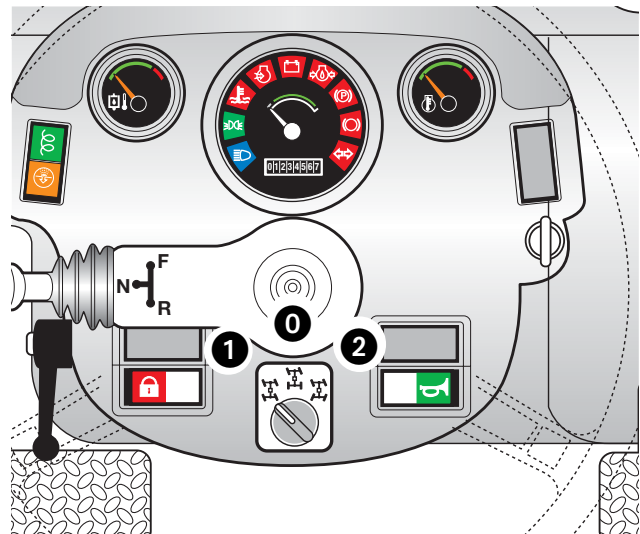

	SERVICE INTERVAL
Running-in _____	None
Ordinary _____	When necessary

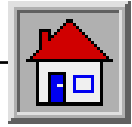

MAINTENANCE

■ D-3.14 ADJUSTING THE SLIDING PADS OF THE BOOM SECTIONS

Any boom section is fitted with adjustable pads located on the four sides of the profile. These pads are secured to both fixed and mobile part of every section.

All pads can be adjusted by the special shims supplied by GENIE upon demand.

Adjusting the pads:

- Remove or loosen the screws fixing the pads in relation to type of shims used (with or without slots).
- Fit the necessary amount of shims.
- If the residual thickness of the pad is insufficient or near the maximum wearing limit, renew the pad.
- Tighten the screws fixing the pads at the recommended torque (see below). Use a dynamometric wrench.

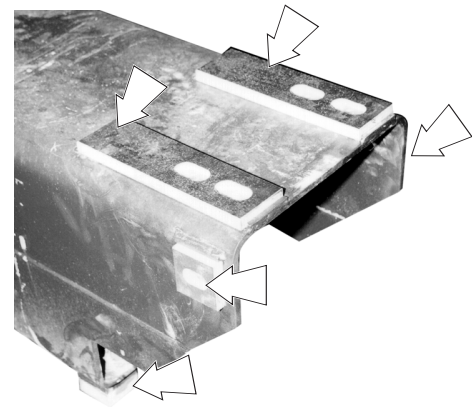
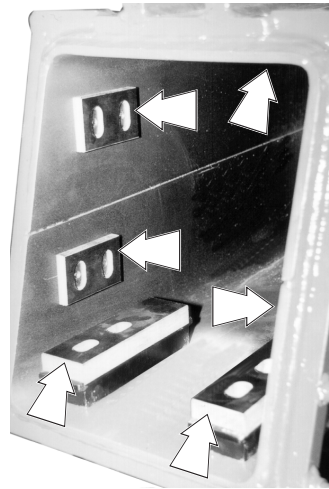

Tightening torques of the pad screws in relation to the screw diameter

Screws M10	Nm 30
Screws M14	Nm 50

Tightening torques higher than those recommended can cause the break of the pad or of the locking threaded bush.

ATTENTION

Pads must compulsorily be replaced if the residual thickness of the plastic layer with respect to the iron bush fixing the block is equal or inferior to 1 mm.

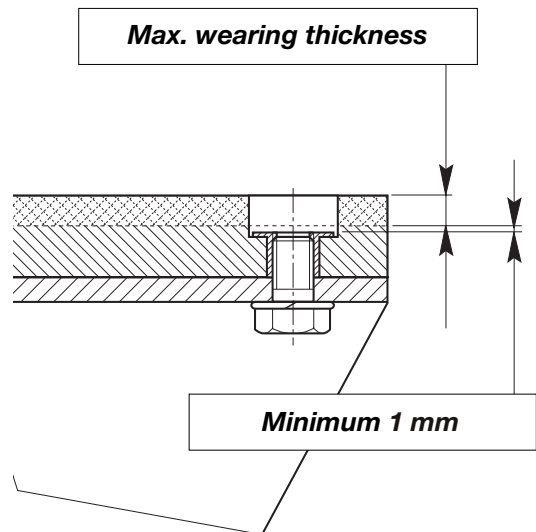

SERVICE INTERVAL

Running-in _____ **None**

Ordinary _____ **When necessary**

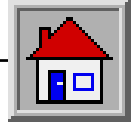

MAINTENANCE

■ **D-3.15 CHECKING THE SAFETY DEVICES**

■ **Checking the block valves** (every 3 months).

The piloted blocking valves allow to held the load in position in case of burst of a flexible hose.

To check the efficiency of a valve, proceed as follows:

- Load a weight near the maximum payload (2400 kg roughly) onto the boom.
- Raise the load some centimetres above the ground (max 10 cm). To check the valve on the telescope extension cylinder move the boom to maximum height and extend it some centimetres.
- Loosen the oil hoses to the cylinder of which you are checking the valve with caution.

During the check, the oil will flow out of the hoses and the load shall remain blocked in position. Should that not be the case, the valve must be replaced. Contact GENIE Technical Service.



- **Wear safety glasses**
- **Wear safety gloves**
- **Wear safety shoes**
- **Wear suitable working clothes**
- **Use guards against leaks of oil at high pressure**
- **Do the check in a free space with barriers all around to keep non-authorized people away**
- **During the check proceed with extreme caution.**
- **Ensure that the part to be checked is in safe condition and that the action generated does not result in an uncontrolled movement of the machine**

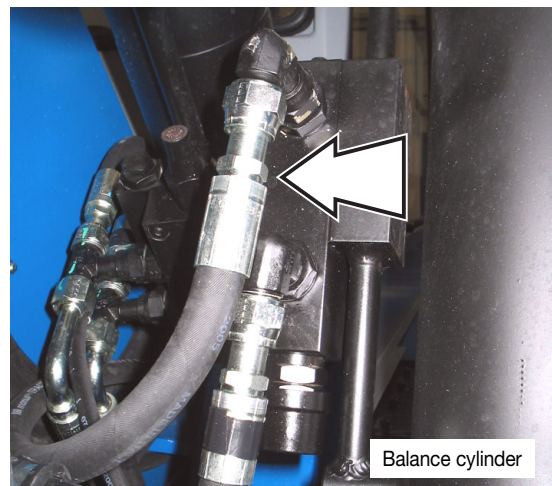
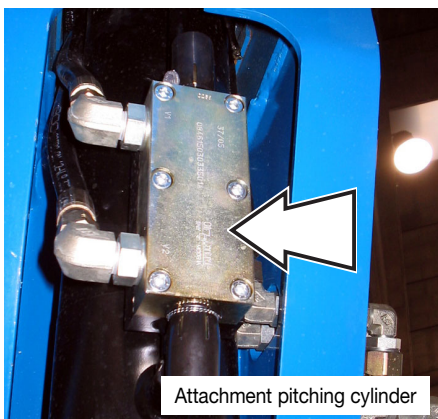
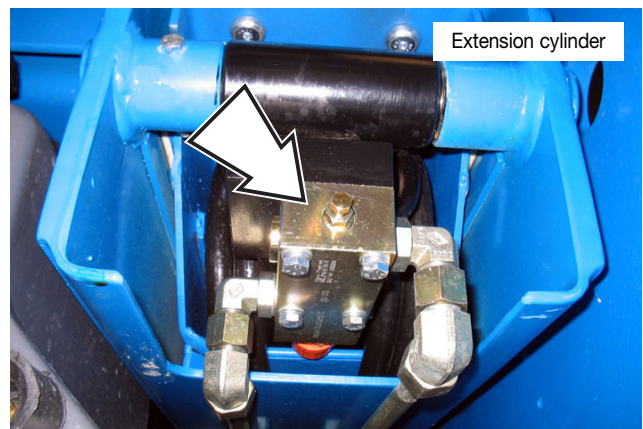
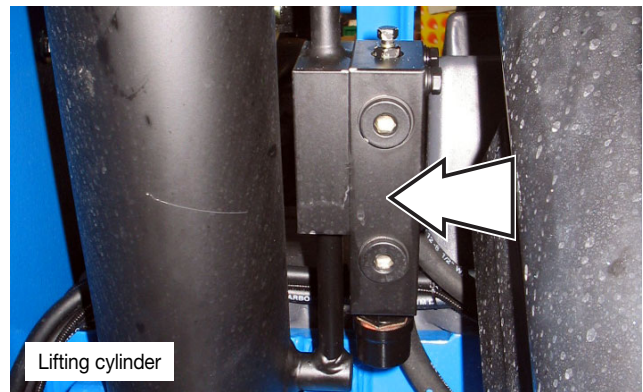
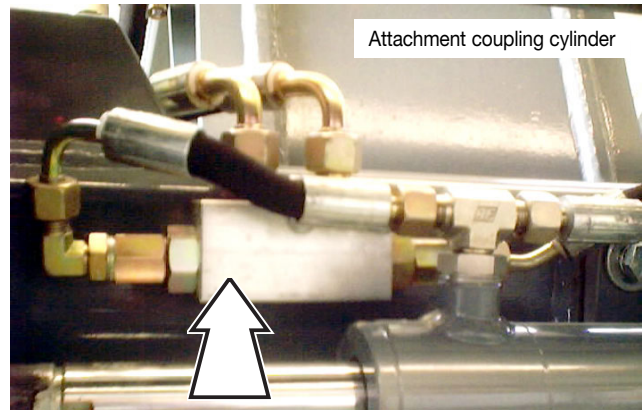

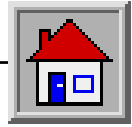

MAINTENANCE

■ **Checking the machine start control**

(at every use)

Attempt to start the engine with the forward or reverse gear put.

The engine must not start. If the engine starts, contact the GENIE Technical Service.

Repeat the operation putting first one gear, then the other.

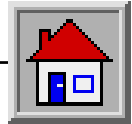

MAINTENANCE

D-4 ELECTRICAL SYSTEM



All maintenance interventions must be carried out with engine stopped, parking brake engaged, working attachments on the ground and gearbox lever in neutral.



When raising a component for maintenance purposes, secure it in a safe way before carrying out any maintenance.

D-4.1 BATTERY

- Check the electrolyte level every 250 working hours; if necessary, add distilled water.
- Ensure the fluid is 5÷6 mm above the plates and the cell levels are correct.
- Check the cable clips are well secured to the battery terminals. To tighten the clips, always use a box wrench, never pliers.
- Protect the terminals smearing them with pure vaseline.
- Remove the battery and store it in a dry place, when the machine is not used for a long time.



- **Battery electrolyte contains sulphuric acid. It can burn you if it touches your skin and eyes. Always wear goggles and protective gloves, and handle the battery with caution to prevent spillage. Keep metal objects (watch straps, rings, necklaces) clear of the battery leads, since they can short the terminals and burn you.**

- *Before disconnecting the battery, set all switches within the cab to OFF.*
- *To disconnect the battery, disconnect the negative (-) lead from the frame earth first.*
- *To connect the battery, connect the positive (+) lead first.*
- *Recharge the battery far from the machine, in a well-ventilated place.*
- *Keep out of items which can produce sparks, of naked flames or lit cigarettes.*
- *Do not rest metal objects onto the battery. This can result in a dangerous short especially during a recharge.*
- *Because the electrolyte is highly corrosive, it must never come in contact with the frame of the handler or electric/electronic parts. If the electrolyte comes in contact with these parts, contact the nearest authorised assistance centre.*



Risk of explosion or shorts. During the recharge, an explosive mixture with release of hydrogen gas forms.



Do not add sulphuric acid; add only distilled water.

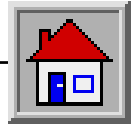

MAINTENANCE

D-4.2 FUSES AND RELAYS

The electrical system is protected by fuses placed in the driving cab, on the left. Before replacing a blown fuse with a new one having the same amperage, find out and rectify the fault.

Fuses

Ref.	Circuit	Amp.
F1	Interior lamp power supply	2
F2	Frontwork light switch power supply	10
F3	Rear work light switch power supply	10
F4	E1 relay pickup, E2 relay pickup, E3 relay pickup, Relay E6 power supply, hydraulic stop, warning lights-fuel gauge instrument, air filter soiled warning light, preheating warning light, engine oil cooling temperature indicator light, engine oil temperature indicator	5
F5	Power supply: engine stop solenoid, preheating control unit	10
F6	Horn switch power supply	10
F7	Vse solenoid valve switch power supply	5
F8	Parking brake switch power supply	5
F9	Windscreen wiper/washer motor power supply	15
F10	Windscreen wiper/washer switch power supply	5
F11	Power supply: beacon, lighting: warning lights, fuel gauge, engine oil temperature indicator, engine oil cooling temperature indicator	7.5
F12	Power supply: steering selector	7.5
F13	Relay E3/Relay E5 power supply	5
F14	Not used	5
F15	Not used	2
F16	Not used	10
F17	Not used	10
F18	Not used	5
F19	Not used	10
F20	Not used	10
F21	Not used	5
F22	Not used	5
F23	Not used	15
F24	Not used	5
F25	Not used	7.5

Ref.	Circuit	Amp.
F26	Not used	7.5
F27	Not used	5
F28	Not used	5
F29	Spare fuses	

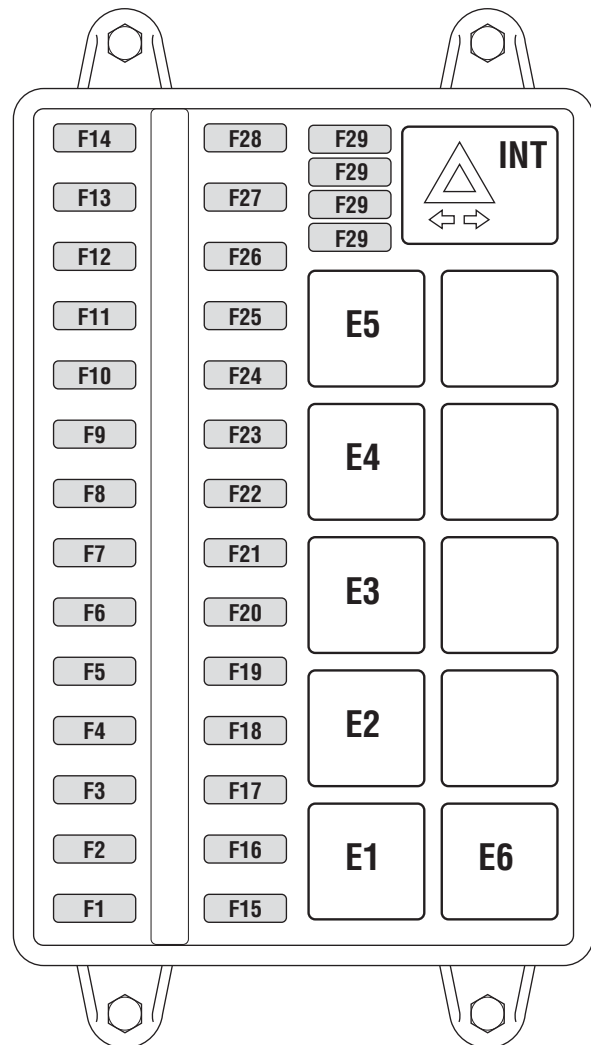

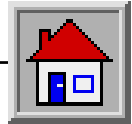

MAINTENANCE

■ **Engine compartment fuses and relays**

Ref.	Circuit	Amp
F30	Timer fuse	70
F31	Start-up and main board fuse	50
E11	Glow plugs timer relay	
E12	Start relay	

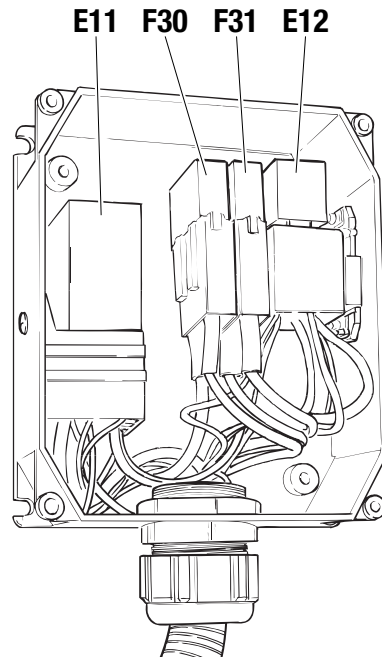

■ **Fuse box relays**

Ref.	Circuit
E1	Front/rear work lights
E2	Engine start with parking brake engaged
E3	Relay E4 enabling command
E4	Forward speed enabling command
E5	Reverse speed
E6	Stop

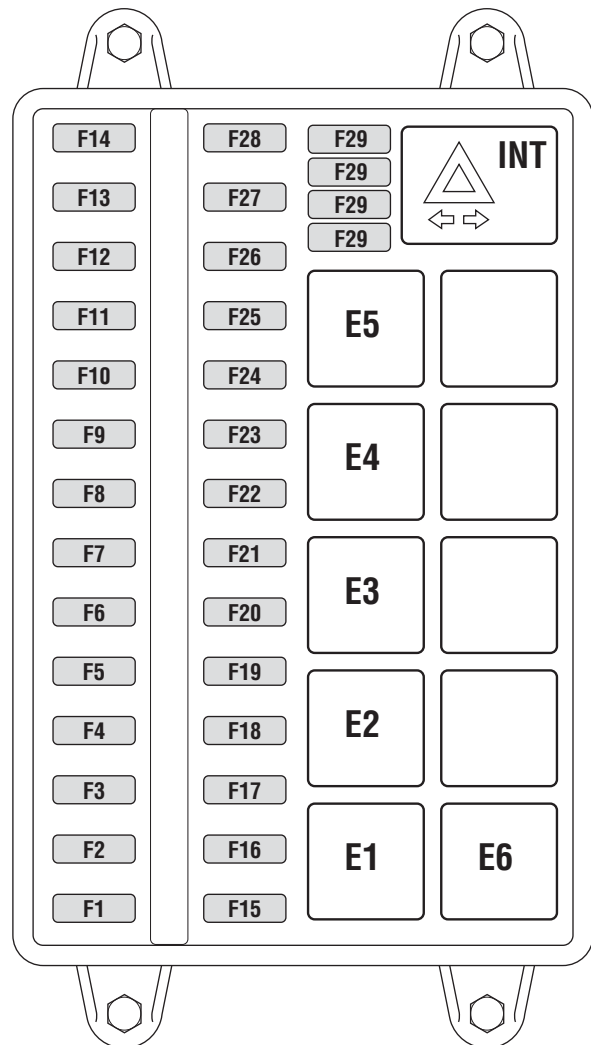

ATTENTION

- **Do not use fuses having a higher amperage than that recommended, since they can damage the electric system seriously.**
- **If the fuse blows after a short time, look for the fault source by checking the electric system.**
- **Always keep some spare fuses for an emergency.**
- **Never try to repair or short blown fuses.**
- **Make sure the contacts of fuses and fuse-sockets ensure a good electric connection and are not oxidised.**

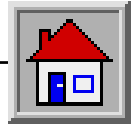

MAINTENANCE

D-5 REFUELLING

D-5.1 REFUELLING

Part	Product	Capacity (litres)	Product specifications see par.
Diesel engine	Engine oil	11 + 3.5	D-5.2.1
Fuel tank	Diesel fuel	60	D-5.2.3
Hydraulic system tank	Hydraulic oil	120	D-5.2.2
Front differential gear with reduction gear	Oil	6	D-5.2.2
Rear differential gear	Oil	5	D-5.2.2
Front wheel reduction gears	Oil	1.5 + 1.5	D-5.2.2
Rear wheel reduction gears	Oil	0.7 + 0.7	D-5.2.2
Brake oil tank	Hydraulic oil	0.1	D-5.2.2

D-5.2 PRODUCT SPECIFICATIONS

D-5.2.1 Engine oil

Use the oil recommended by the Diesel engine Manufacturer (see the relevant handbook delivered with the machine).

At the delivery, the machine is refilled with:

SHELL RIMULA 15W-40

D-5.2.2 Lubrication oils and relevant filtering elements

Refill the machine with following lubricants:

Use	Product	Definition
Power divider-Differential gears-Reduction gears	FUCHS TITAN GEAR LS 85 W-90	API GL-5 LS / GL-5
Hydraulic system and brakes	SHELL TELLUS T 46	DENISON HF-1 DIN 51524 part 3 Cat. HV



Never mix different oils: this may result in troubles and component breaks.

Filtering elements:

Filter	Flow l/1'	Filtering	Code
Transmission oil filter	MPS 150	10 µ	09.4604.0001
Auxiliary circuit oil filter (inside the tank)	STR 100/1	60 µ	09.4604.0004

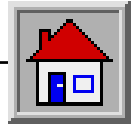

MAINTENANCE

■ D-5.2.3 Fuel

Use only Diesel fuel with less than 0.5% sulphur content, according to the specifications of the diesel engine operation handbook.

ATTENTION

In cold climates (temperature under -20°C) use only "Arctic" type Diesel fuel, or oil-diesel fuel, or oil-diesel fuel mixtures. The composition of the latter can vary in relation to the ambient temperature up to max. 80% oil.

■ D-5.2.4 Grease

For the machine greasing, use:

- | | |
|--|--|
| • Lithium-based Vanguard LIKO grease, type EP2 | When greasing by pump |
| • Graphitized SHELL grease, type GR NG 3 | When greasing by brush |
| • INTERFLON FIN GREASE LS 2 | For the telescopic boom sliding blocks |

ATTENTION

Avoid mixing greases of different type or features and do not use greases of lower quality.

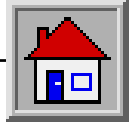

MAINTENANCE

Intentionally blank page

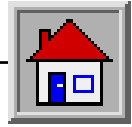

FAULTS AND TROUBLESHOOTING

Section E

**FAULTS AND
TROUBLESHOOTING**

TABLE OF CONTENTS

E-1	FAULTS AND TROUBLESHOOTING	E-2
E-1.1	Fault - Cause - Solution	E-2

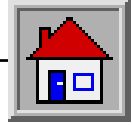

FAULTS AND TROUBLESHOOTING

E-1 FAULTS AND TROUBLESHOOTING

This chapter represents a practical guide for the operator for fixing the most common failures and, at the same time, detecting those interventions which must be carried out by qualified technical engineers. If you are unsure about anything, do not carry out operations on the machine, but call in a skilled technician.



Any repair work, maintenance or troubleshooting must be carried out with machine stopped, boom in rest position or laid on the ground, parking brake engaged and ignition key removed.

E-1.1 Fault - Cause - Solution

<p>DASHBOARD DOES NOT SWITCH ON</p>	<ul style="list-style-type: none"> • The 50A fuse F31 supplying power to the dashboard is blown (engine compartment) • Battery disconnected • Battery down • Battery cut-out switch OFF 	<ul style="list-style-type: none"> • Replace the fuse • Connect the battery using the relevant switch • Check the battery • Switch it on
<p>ENGINE DOES NOT START <i>Starter does not run</i></p>	<ul style="list-style-type: none"> • Parking brake not engaged • Battery down • Battery cut-out switch OFF 	<ul style="list-style-type: none"> • Engage the parking brake and ensure the relevant indicator on the dashboard switches on • Recharge or replace the battery • Switch it on
<p>ENGINE DOES NOT START <i>Starter runs, but engine does not start</i></p>	<ul style="list-style-type: none"> • Fuse F15 blown • No fuel • Diesel fuel filter clogged • Diesel fuel hose empty (fuel used up) • Solenoid valve - engine stop 	<ul style="list-style-type: none"> • Check the fuse • Refuel • See DEUTZ engine operator manual • Refuel, then refer to DEUTZ engine operator manual • Check the solenoid valve; replace, if necessary
<p>MACHINE DOES NOT MOVE</p>	<ul style="list-style-type: none"> • Speed selector switch in neutral • Parking brake engaged • Fuse F3 blown 	<ul style="list-style-type: none"> • Set the speed selector switch correctly • Disengage • Check the fuse; replace, if necessary
<p>THE MACHINE DRIVE IS NOT ENOUGH</p>	<ul style="list-style-type: none"> • Hydraulic oil filter clogged 	<ul style="list-style-type: none"> • Replace the filter
<p>NO SELECTION OF THE STEERING MODE</p>	<ul style="list-style-type: none"> • Fuse F20 controlling the steering selection blown • "ROAD/JOBSITE" switch set to "ROAD" 	<ul style="list-style-type: none"> • Sostituire il fusibile • Set to "JOBSITE"
<p>"ROAD" FUNCTION ON, EVEN WHEN SELECTING THE "JOBSITE" FUNCTION</p>	<ul style="list-style-type: none"> • No "ROAD/JOBSITE" selection 	<ul style="list-style-type: none"> • Check and replace fuse F20, if necessary

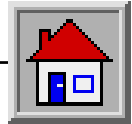

FAULTS AND TROUBLESHOOTING

<p>NO BOOM LOWERING AND EXTENSION, NO HOLDING FRAME TILTING</p>	<ul style="list-style-type: none"> • Fuse blown 	<ul style="list-style-type: none"> • Replace fuses F2 and/or F24
<p>THE HYDRAULIC OIL THERMOMETER DOES NOT WORK</p>	<ul style="list-style-type: none"> • This is normal, when the outside temperature is low and/or the machine is used for short periods, since the hydraulic oil cannot warm up over 40÷50°C 	
<p>THE PARKING BRAKE LIGHT DOES NOT LIGHT UP</p>	<ul style="list-style-type: none"> • Fuse blown 	<ul style="list-style-type: none"> • Replace fuse F15
<p>BOOM DOES NOT MOVE</p>	<ul style="list-style-type: none"> • Fuse blown • “ROAD/JOBSITE” switch set to “ROAD” • Emergency button ON 	<ul style="list-style-type: none"> • Check and replace fuse F22, if necessary • Set to “JOBSITE” • Reset the button

ATTENTION

In case of faults not listed in this chapter, address to the GENIE Technical Assistance, your nearest authorised workshop or dealer.

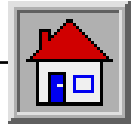

OPTIONAL ATTACHMENTS

Section F

OPTIONAL ATTACHMENTS

TABLE OF CONTENTS

F-1.1	Shovel	F-3
F-1.2	Cereal shovel	F-4
F-1.3	Fixed hook on plate	F-5
F-1.4	Extension jib	F-6
F-1.5	Forks with hydraulic side-shift	F-7

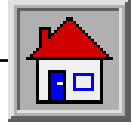

OPTIONAL ATTACHMENTS

INTRODUCTION

This section provides information on the optional interchangeable attachments, especially manufactured for the handlers.

Use only genuine attachments, described in this section, after having read their features thoroughly and understood their use.

To install and remove the attachments, follow the instructions supplied in the **OPERATION** section, par. **C-5.4**.

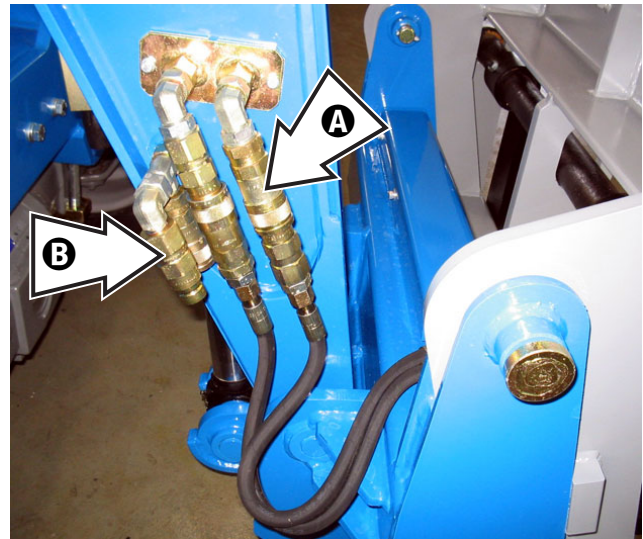

DANGER

When replacing interchangeable attachments, keep any person clear of the working area.



DANGER

Mounting optional attachments, and especially the extension jib, can change the centre of gravity of the machine. Before handling a load, check its weight and compare it with the values on the load charts. The weight of the used attachment must always be deducted from the rated payload.

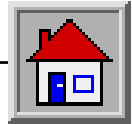

OPTIONAL ATTACHMENTS

■ **F-1.1 SHOVEL**

Code	GTH-5519
Litres 500	59.0200.0000

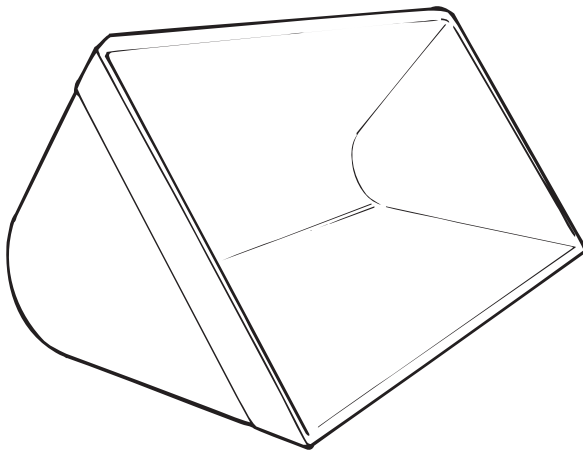

Application

Quick-coupling fitted attachment for moving soil, sand, debris, cereals, etc.

Safety

Strictly obey the general safety precautions given in section **B** "SAFETY".

Operation

ATTENTION

When using a shovel, load the material only when the boom is completely retracted and push against the heap with straight wheels.

To load/unload the material, operate the rotation lever of the attachment holding plate.

Maintenance

Visually check the shovel for damage before using it.

Technical data

Capacity	litres	500
A Width	mm	1850
B Length	mm	760
H Height	mm	700
- Weight	kg	290

ATTENTION

Attachment suitable for moving loose material. Do not use for digging operations.

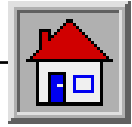

OPTIONAL ATTACHMENTS

■ **F-1.2 CEREAL SHOVEL**

Code	GTH-5519
Litres 800	59.0200.1000

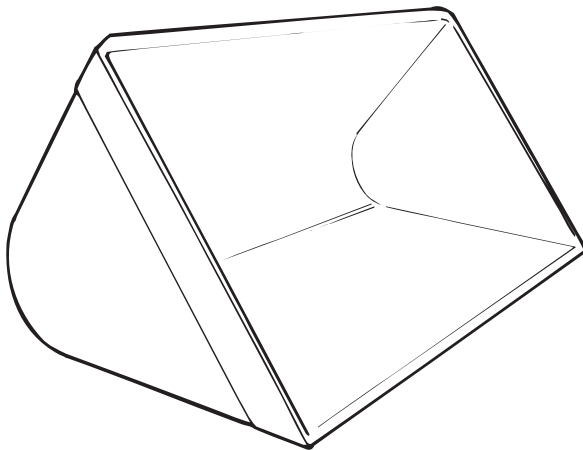

Application

Quick coupling attachment for loading cereals or inert materials, etc.

Safety

Strictly obey the general safety precautions given in section **B** "SAFETY".

Operation

ATTENTION

When using a shovel, load the material only when the boom is completely retracted and push against the heap with straight wheels.

To load/unload the material, operate the rotation lever of the attachment holding plate.

Maintenance

Visually check the shovel for damage before using it.

Technical data

Capacity	litres	800
A Width	mm	1850
B Length	mm	800
H Height	mm	1150
- Weight	kg	350

ATTENTION

Attachment suitable for moving loose material. Do not use for digging operations.

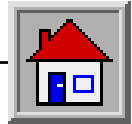

OPTIONAL ATTACHMENTS

■ **F-1.3 FIXED HOOK ON PLATE**

Payload	Code
2500 kg	59.0700.0000

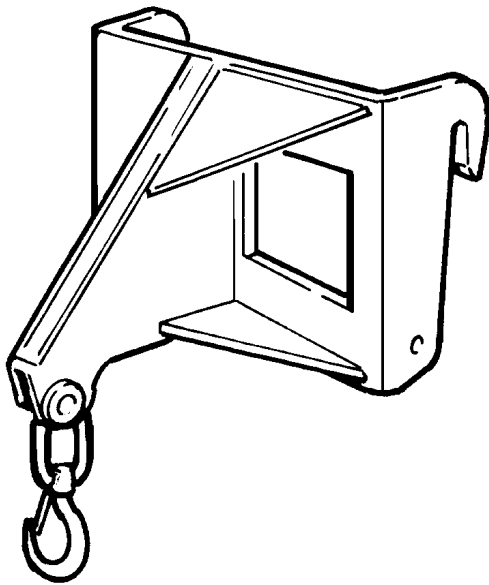

Application

Quick-coupling fitted attachment for lifting loads by means of special slings.

Safety

Strictly obey the general safety precautions given in section **B** "SAFETY".
Do not oscillate the load.
Do not drag hooked loads.
Lift the load before extending the boom.

Operation

Fork the hook and hold it in position by means of the locking cylinder.
All loads must be bridled with special textile slings or chains in compliance with all pertinent regulations.
To handle the load, raise and rotate the telescopic boom of the handler.

Maintenance

Visually check the hook for damage before using it.
Check the safety catch is in good working order.

Technical data

Payload	kg	2500
Width	mm	970
Length	mm	620
Height	mm	600
Weight	kg	105

IMPORTANT

The fixed hook has been designed to support a load of 2500 kg. The max payload corresponds to the nominal capacity rating of the handler on which it is installed and is indicated on the load charts supplied with the equipment.

IMPORTANT

*Make sure this attachment can be used in the destination country of the machine. In Italy, this attachment must be enrolled at ISPESL and submitted to yearly test.
Application must be submitted directly by the user.*

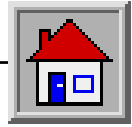

OPTIONAL ATTACHMENTS

■ **F-1.4 EXTENSION JIB**

Code	GTH-5519
400 kg	59.0800.0000

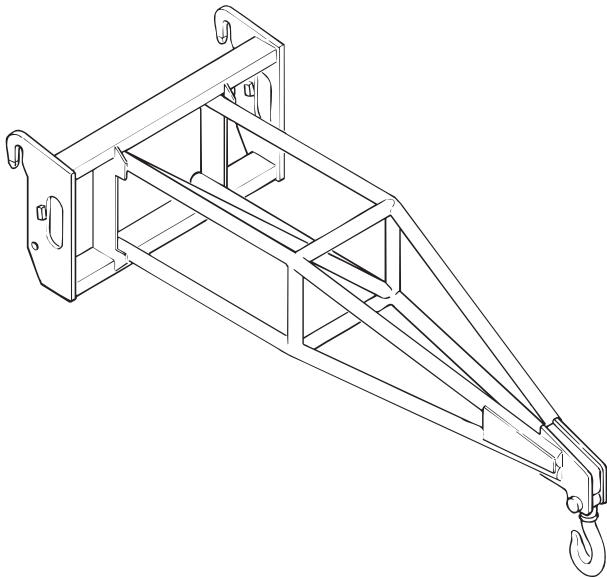

Application

Quick-coupling fitted attachment for maintenance interventions at high working heights.

Safety

Strictly obey the general safety precautions given in section **B** "SAFETY".

Never lift wrongly slung loads.

Avoid abrupt acceleration or deceleration.

Avoid load oscillations, and especially do not move the load from the vertical pull line.

Do not pull crosswise and do not tow.

Operation

To change the working height, operate the rotation lever of the attachment holding plate.

Maintenance

Visually check the jib for damage before using it.

Check the safety catch is in good working order.

Daily grease the joints using the greasing gun.

Characteristics		
- Payload	kg	400
A Length	mm	2100
B Width	mm	920
H Height	mm	630
- Weight	kg	115

IMPORTANT

Make sure this attachment can be used in the destination country of the machine. In Italy, this attachment must be enrolled at ISPESL and submitted to yearly test.

Application must be submitted directly by the user.

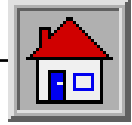

OPTIONAL ATTACHMENTS

■ **F-1.5 FORKS WITH HYDRAULIC SIDE-SHIFT**

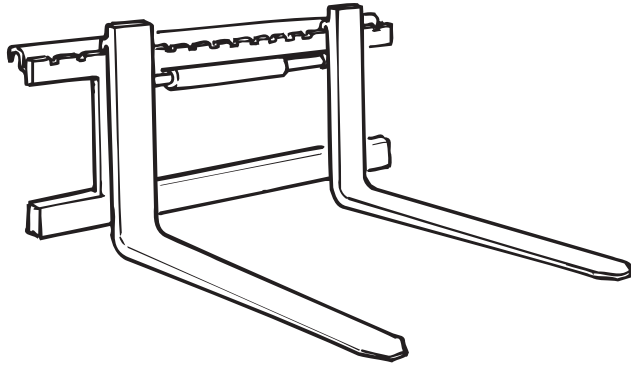

Application

Quick-coupling fitted attachment for handling palletised loads with possibility of shifting the load to the side by ± 100 mm.

Safety

Strictly obey the general safety precautions given in section **B** "SAFETY".

- Do not load loose materials
- Do not move superposed pallets

Operation

To adjust the tilting, operate the rotation lever of the attachment holding plate.

To side-shift, operate the attachment locking lever after connecting the feeding lines of the new attachment to the quick couplings (see page F-2).

Maintenance

Visually check the attachment for damage before using it. Check for hydraulic oil leaks.

Daily grease the joints using a greasing gun, and smear the sliding guides with graphitized grease.

Machine	GTH-5519
Code	59.0600.0000

Technical data

Payload kg		2600
Width	mm	1240
Length	mm	1600
Height (with protection)	mm	1000
Weight	kg	180
Stroke	mm	± 100
Fork attachments		FEM 2

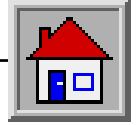

OPTIONAL ATTACHMENTS

Intentionally blank page

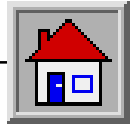

TABLES AND DOCUMENTS ENCLOSED

Section G

**TABLES AND
DOCUMENTS ENCLOSED**

TABLE OF CONTENTS

G-1	TORQUE WRENCH SETTING	G-2
G-2.1	Load Chart with forks (up to serial no. 14976)	G-3
G-2.2	Load Chart with forks (from serial no. 14977)	G-4
G-3.1	Wiring diagram - Fuses and relays	G-5
G-3.2	Wiring diagram - fuses system	G-7
G-3.3	Wiring diagram - dashboard system	G-8
G-3.4	Wiring diagram - chassis system	G-9
G-3.5	General wiring diagram (description)	G-10
G-4.1	Hydraulic scheme	G-11
G-5	Routine check schedule-Safety devices	G-12

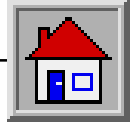

TABLES AND DOCUMENTS ENCLOSED

G-1 TORQUE WRENCH SETTINGS

D x p	Pre-loading (N)				Torque wrench setting (Nm)			
	4.8	8.8	10.9	12.9	4.8	8.8	10.9	12.9
M 4 x 0,7	1970	3930	5530	6640	1,5	3,1	4,3	5,2
M 5 x 0,8	3180	6360	8950	10700	3	6	8,5	10,1
M 6 x 1	4500	9000	12700	15200	5,2	10,4	14,6	17,5
M 8 x 1,25	8200	16400	23100	27700	12,3	24,6	34,7	41,6
M 8 x 1	8780	17600	24700	29600	13	26	36,6	43,9
M 10 x 1,5	13000	26000	36500	43900	25,1	50,1	70,5	84,6
M 10 x 1,25	13700	27400	38500	46300	26,2	52,4	73,6	88,4
M 12 x 1,75	18900	37800	53000	63700	42,4	84,8	119	143
M 12 x 1,25	20600	41300	58000	69600	45,3	90,6	127	153
M 14 x 2	25800	51500	72500	86900	67,4	135	190	228
M 14 x 1,5	28000	56000	78800	94500	71,7	143	202	242
M 16 x 2	35200	70300	98900	119000	102	205	288	346
M 16 x 1,5	37400	74800	105000	126000	107	214	302	362
M 18 x 2,5	43000	86000	121000	145000	142	283	398	478
M 18 x 1,5	48400	96800	136000	163000	154	308	434	520
M 20 x 2,5	54900	110000	154000	185000	200	400	562	674
M 20 x 1,5	60900	122000	171000	206000	216	431	607	728
M 22 x 2,5	67900	136000	191000	229000	266	532	748	897
M 22 x 1,5	74600	149000	210000	252000	286	571	803	964
M 24 x 3	79100	158000	222000	267000	345	691	971	1170
M 24 x 2	86000	172000	242000	290000	365	731	1030	1230
M 27 x 3	103000	206000	289000	347000	505	1010	1420	1700
M 27 x 2	111000	222000	312000	375000	534	1070	1500	1800
M 30 x 3,5	126000	251000	353000	424000	686	1370	1930	2310
M 30 x 2	139000	278000	391000	469000	738	1480	2080	2490

IMPORTANT

Sensor maximum driving torque: 15 Nm.

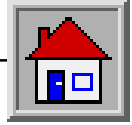

TABLES AND DOCUMENTS ENCLOSED

G-2.1 LOAD CHART WITH FORKS - GTH-5519

GTH-5519	
From serial no.	xxxxx
To serial no.	14976

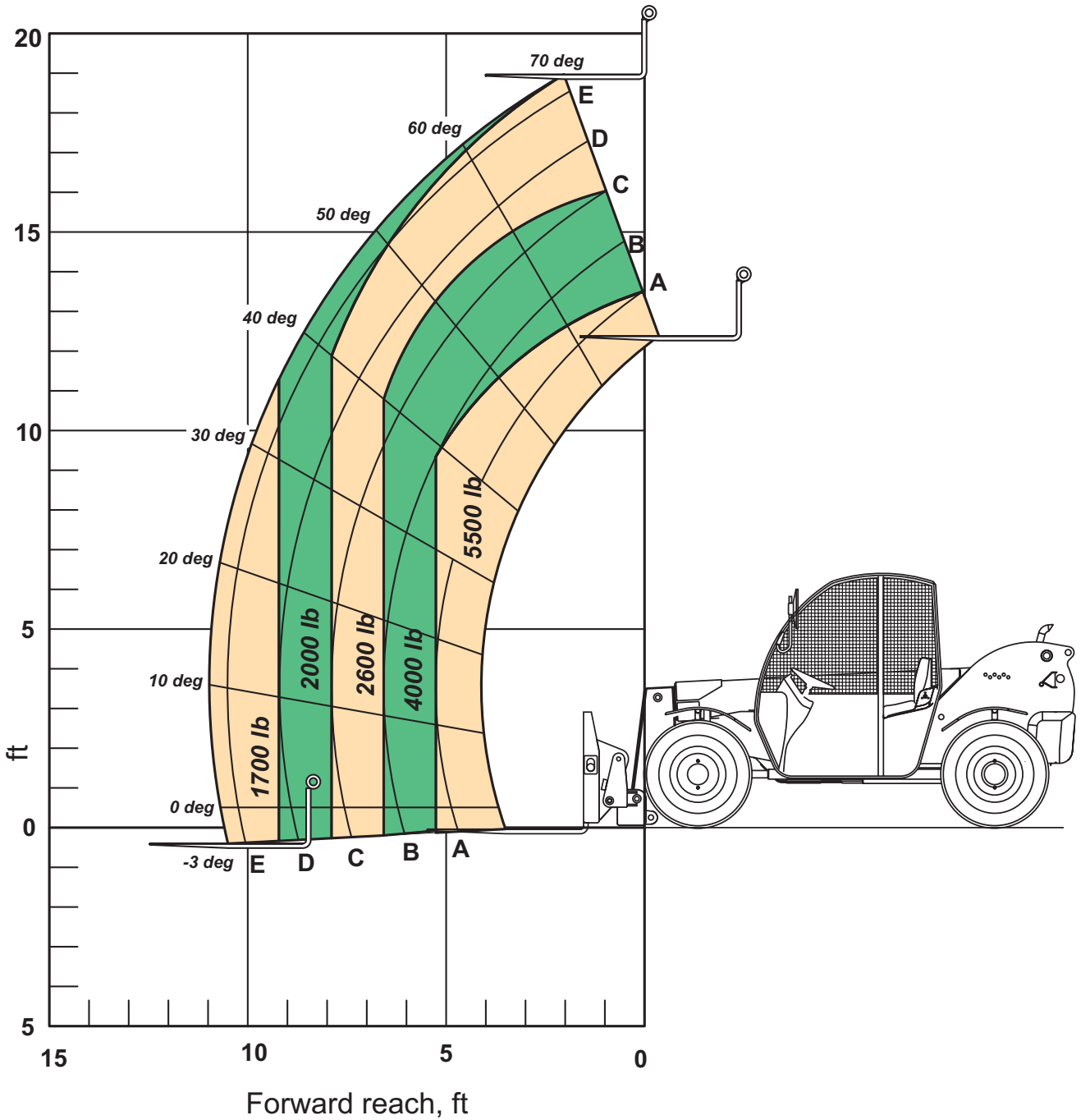

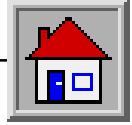

TABLES AND DOCUMENTS ENCLOSED

G-2.2 LOAD CHART WITH FORKS - GTH-5519

GTH-5519	
From serial no.	14977
To serial no.	xxxxx

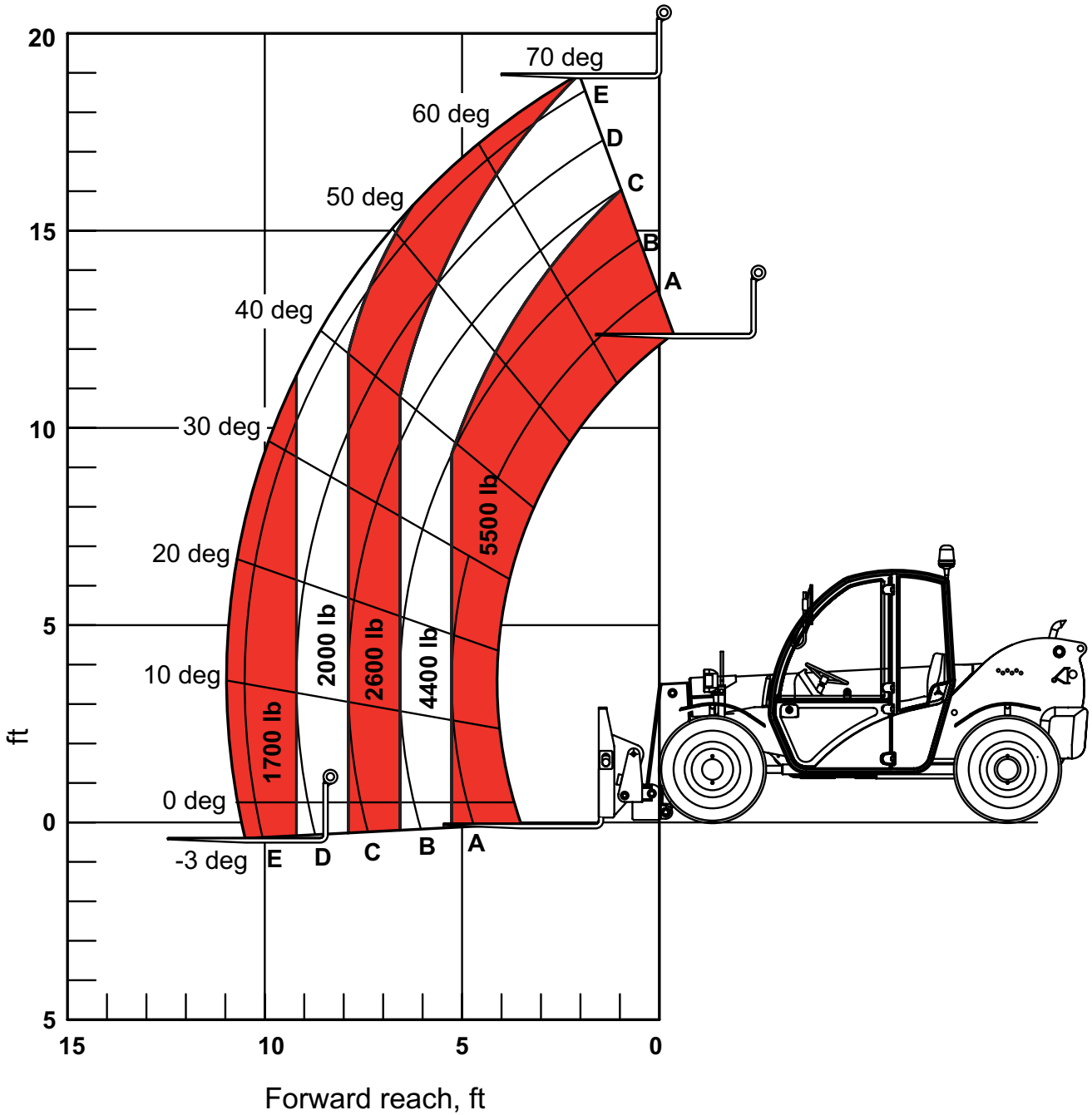

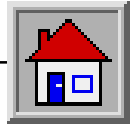

TABLES AND DOCUMENTS ENCLOSED

■ G-3.1 WIRING DIAGRAM - FUSES AND RELAYS

FUSES

Ref.	Circuit	Amp.
F1	Interior lamp power supply	2
F2	Frontwork light switch power supply	10
F3	Rear work light switch power supply	10
F4	E1 relay pickup, E2 relay pickup, E3 relay pickup, Relay E6 power supply, hydraulic stop, warning lights-fuel gauge instrument, air filter soiled warning light, preheating warning light, engine oil cooling temperature indicator light, engine oil temperature indicator	5
F5	Power supply: engine stop solenoid, preheating control unit	10
F6	Horn switch power supply	10
F7	Vse solenoid valve switch power supply	5
F8	Parking brake switch power supply	5
F9	Windscreen wiper/washer motor power supply	15
F10	Windscreen wiper/washer switch power supply	5
F11	Power supply: beacon, lighting: warning lights, fuel gauge, engine oil temperature indicator, engine oil cooling temperature indicator	7.5
F12	Power supply: steering selector	7.5
F13	Relay E3/Relay E5 power supply	5
F14	Not used	5
F15	Not used	2
F16	Not used	10
F17	Not used	10
F18	Not used	5
F19	Not used	10
F20	Not used	10
F21	Not used	5
F22	Not used	5
F23	Not used	15
F24	Not used	5
F25	Not used	7.5
F26	Not used	7.5
F27	Not used	5
F28	Not used	5
F29	Spare fuses	
Engine compartment fuses		
F30	Timer fuse	50
F31	Start-up and main board fuse	50

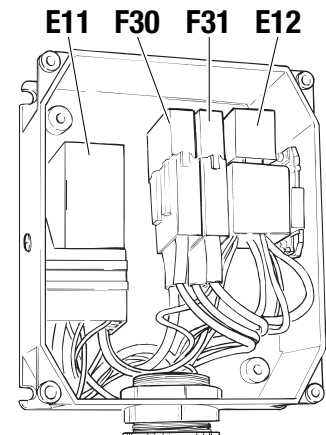
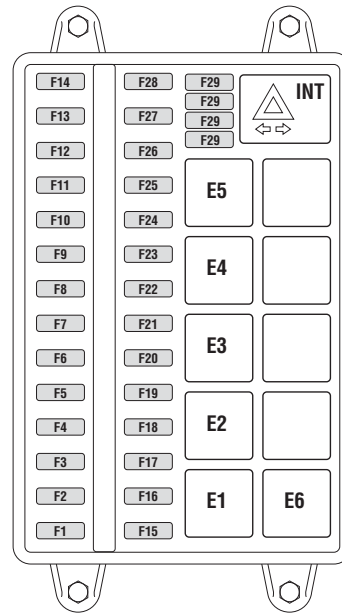

RELAYS

Ref.	Circuit
E1	Front/rear work lights
E2	Engine start with parking brake engaged
E3	Relay E4 enabling command
E4	Forward speed enabling command
E5	Reverse speed
E6	Stop
E11	Glow plugs timer relay
E12	Start relay

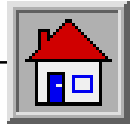

TABLES AND DOCUMENTS ENCLOSED

Intentionally blank page

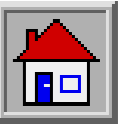

■ G-3.3 WIRING DIAGRAM - DASHBOARD SYSTEM

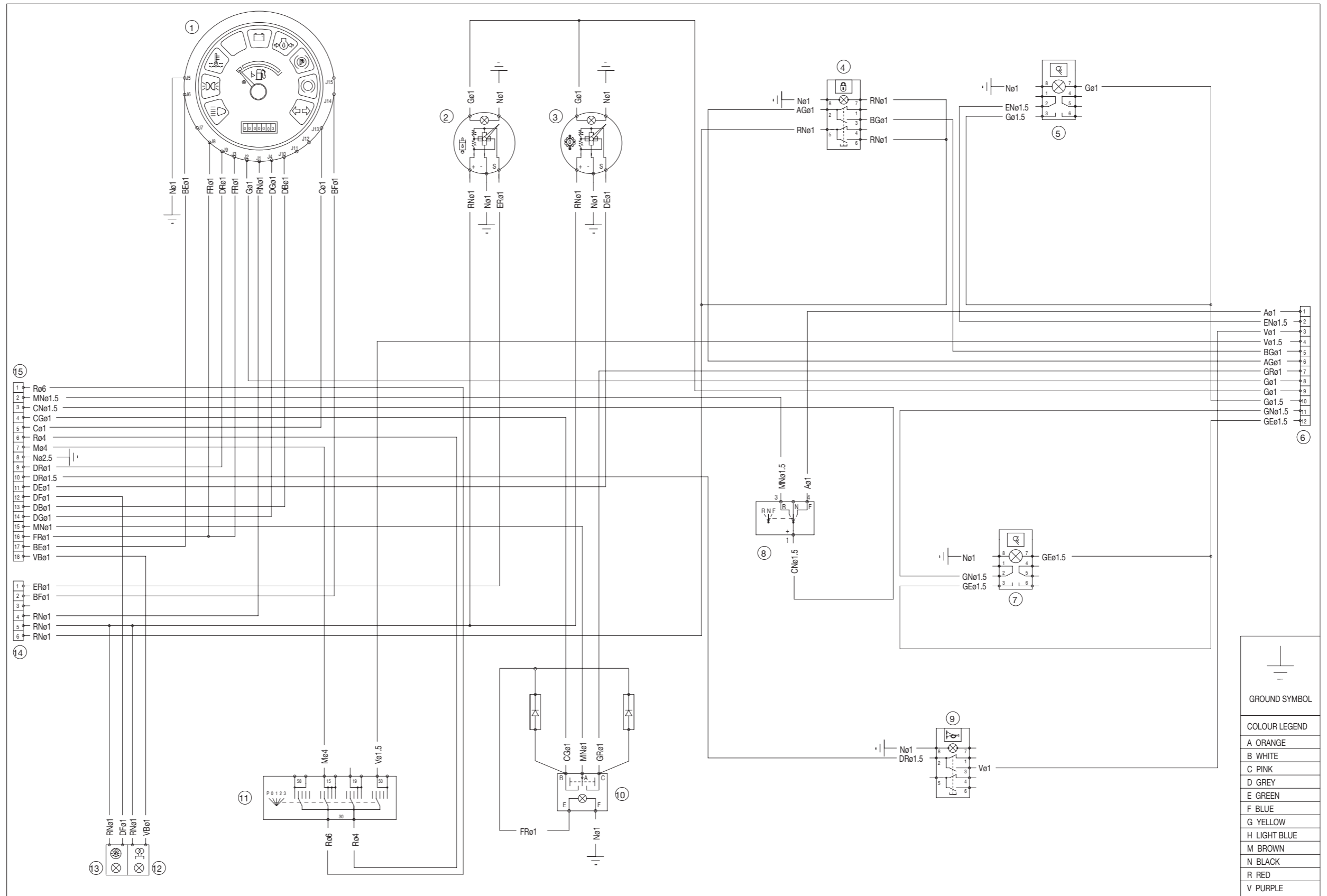

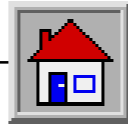

■ G-3.4 WIRING DIAGRAM - CHASSIS SYSTEM

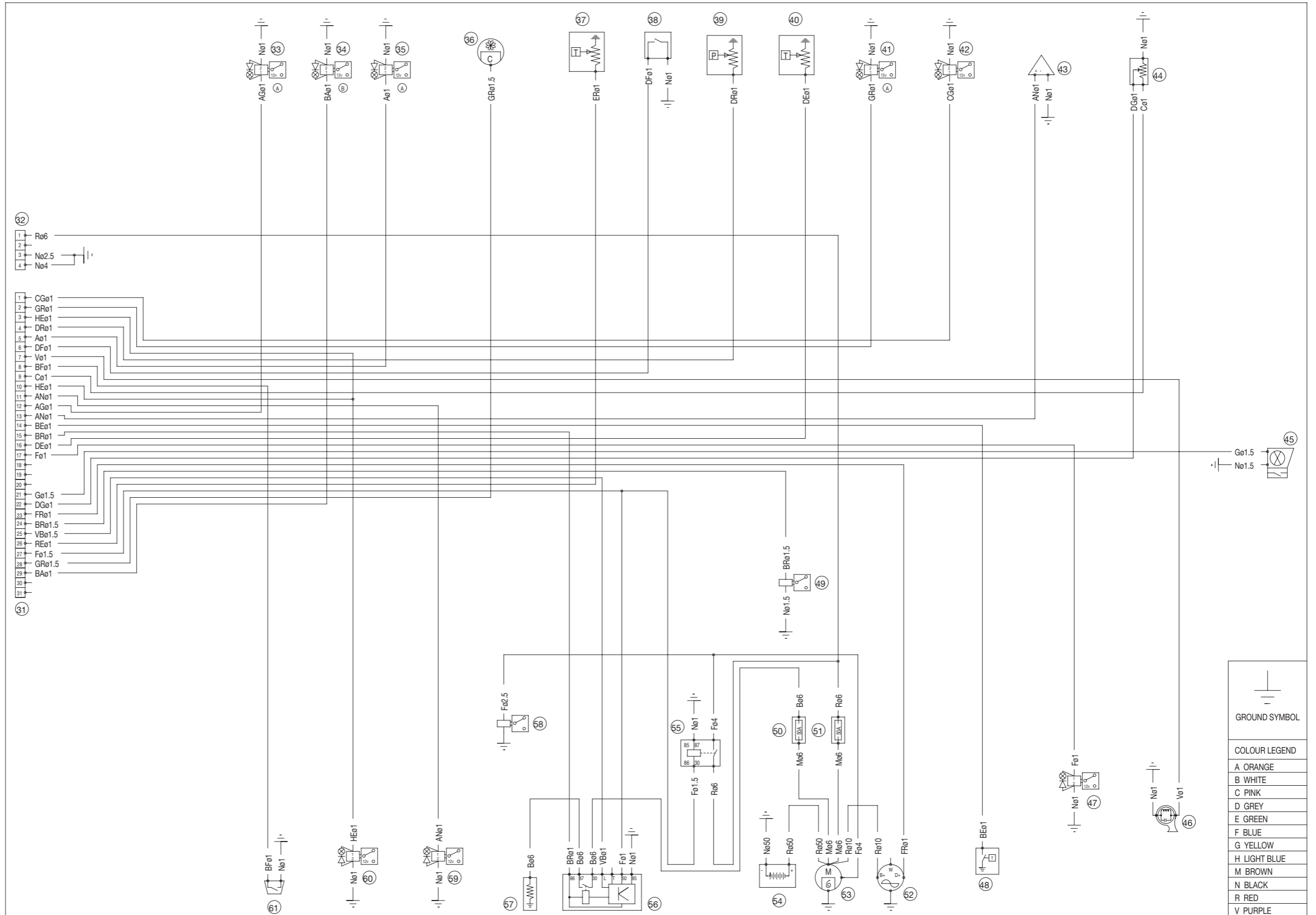

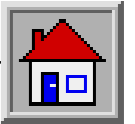

TABLES AND DOCUMENTS ENCLOSED

■ **G-3.5 GENERAL WIRING DIAGRAM** (description)

Ref.	Description	Ref.	Description
1	WARNING LIGHTS-FUEL GAUGE	37	HYDRAULIC OIL TEMPERATURE SENSOR
2	ENGINE OIL TEMPERATURE TRANSDUCER	38	AIR FILTER CLOGGING SENSOR
3	ENGINE OIL COOLING TEMPERATURE INDICATOR	39	ENGINE OIL PRESSURE TRANSDUCER
4	MOVEMENT STOP SWITCH	40	OIL TEMPERATURE INDICATOR SENSOR
5	REAR WORK LIGHT SWITCH	41	WHEEL STEERING SOLENOID VALVE
6	12-WAY CONNECTOR - STEERING COLUMN LINE CONNECTION TO CAB LINE	42	WHEEL STEERING SOLENOID VALVE
7	FRONT WORK LIGHT SWITCH	43	BACK-UP HORN
8	CHANGEOVER-OVER SWITCH	44	FUEL FLOAT
9	HORN SWITCH	45	WORK LIGHT
10	STEERING SELECTOR	46	HORN
11	IGNITION KEY SWITCH	47	HIGH SPEED SOLENOID VALVE
12	PREHEATING GLOW PLUGS WARNING LIGHT	48	ENGINE OIL COOLING TEMPERATURE SENSOR
13	AIR FILTER SOILED WARNING LIGHT	49	ENGINE STOP SOLENOID
14	6-WAY CONNECTOR - STEERING COLUMN LINE CONNECTION TO CAB LINE	50	PREHEATING CONTROL UNIT MAXIFUSE
15	18-WAY CONNECTOR - STEERING COLUMN LINE CONNECTION TO CAB LINE	51	SYSTEM PROTECTION FUSE
16	HYDRAULIC STOP	52	ALTERNATOR
17	PARKING BRAKE SWITCH	53	STARTER MOTOR
18	VSE SOLENOID VALVE CONTROL	54	12V BATTERY
19	FUSES AND RELAYS BOX	55	STARTING RELAY
20	WINDSCREEN WIPER/WASHER SWITCH	56	PREHEATING CONTROL UNIT
21	FRONT WINDSCREEN WIPER/WASHER MOTOR	57	GLOW PLUGS
22	REAR WINDSCREEN WIPER/WASHER MOTOR	58	ENGINE STOP SOLENOID VALVE
23	SEAT SWITCH	59	SOLENOID VALVE - REVERSE SPEED
24	6-WAY CONNECTOR - FUSES LINE CONNECTION TO CAB LINE	60	VSE SOLENOID VALVE
25	CAB LIGHTING	61	NEGATIVE BRAKE PRESSURE SWITCH
26	BEACON		
27	WORK LIGHT		
28	OPTIONAL FLASHING CONNECTOR		
29	JOYSTICK CONNECTOR		
30	OPTIONAL 3-WAY CONNECTOR		
31	31-WAY CONNECTOR - FUSES LINE CONNECTION TO ENGINE LINE		
32	4-WAY CONNECTOR - FUSES LINE CONNECTION TO ENGINE LINE		
33	SOLENOID VALVE - ATTACHMENT RELEASE		
34	SOLENOID VALVE - ATTACHMENT COUPLING		
35	SOLENOID VALVE - FWD SPEED		
36	COMPRESSED AIR COMPRESSOR		



G-4.1 HYDRAULIC SCHEME

