



S3215L

S3215E

S3219E

S3220E

S3226E

S4726E

S4732E

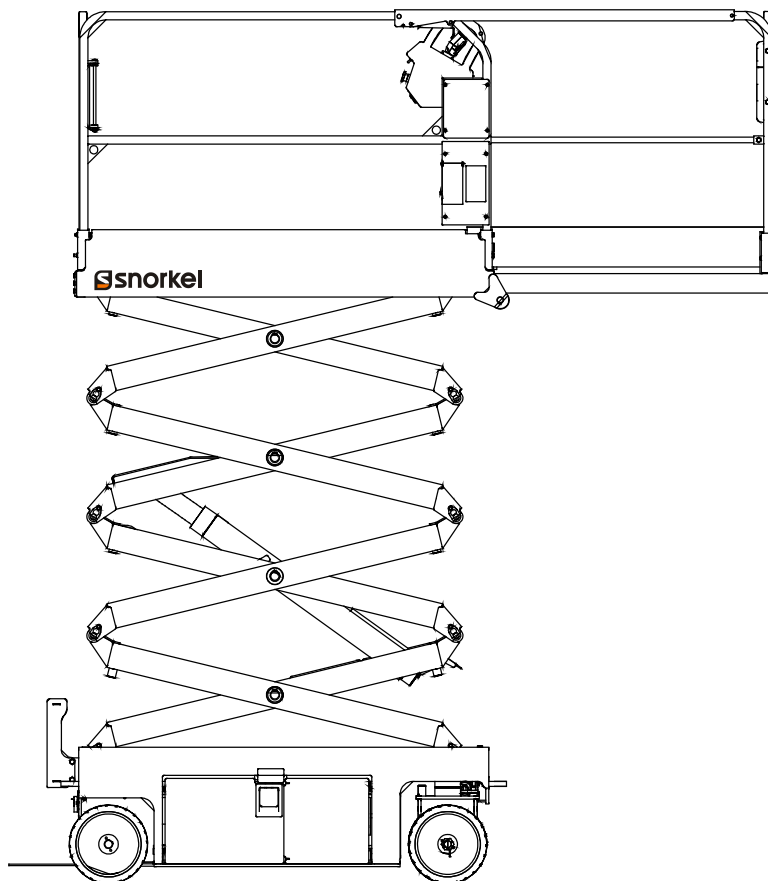

CE

OPERATOR'S MANUAL

ANSI/CSA/CE/AS/NZS
Serial number 00017, 00019 and after
Replaces February 2023

Part Number 1500834
July 2023
Original Instructions

DANGER

The aerial platform is not electrically insulated. Death or serious injury will result from contact with, or inadequate clearance from, an energized conductor.

Do not go closer than the minimum safe approach distance as defined by the Minimum Safe Approach Distance section in Chapter 3–Safety.

Regard all conductors as energized.

Allow for electrical wire sag and aerial platform sway.

If the platform, scissors structure, or any part of the aerial platform contacts a high-voltage electrical conductor, the entire machine can become electrically charged.

If that happens, remain on the machine and do not contact any other structure or object. This includes the ground, adjacent buildings, poles, and any other objects that are not part of the aerial platform.

Such contact could make your body a conductor to the other object, creating an electrical shock hazard resulting in death or serious injury.

If an aerial platform is in contact with an energized conductor the platform operator must warn ground personnel in the vicinity to stay away. Their bodies can conduct electricity creating an electrical shock hazard resulting in death or serious injury.

Do not approach or leave the aerial platform until the electricity has been turned off.

Do not attempt to operate the lower controls when the platform, scissors structure, or any part of the aerial platform is in contact with a high-voltage electrical conductor or if there is an immediate danger of such contact.

Personnel on or near an aerial platform must be continuously aware of electrical hazards, recognizing that death or serious injury can result from contact with an energized conductor.

California

Proposition 65 Warning

Battery posts, terminals, and related accessories contain lead and lead components, chemicals known to the State of California to cause cancer and birth defects or other reproductive harm. Wash hands after handling.

DANGER



Do NOT Go Closer Than The Minimum Safe Approach Distance



Do NOT Operate Outside During a Thunderstorm



Do NOT Operate in Windy or Gusty Conditions



Do NOT Add Anything That Will Increase Wind Loading



Do NOT Drive an Elevated MEWP on Soft, Uneven or Sloping Surfaces



Do NOT Operate an Elevated MEWP on Rough or Uneven Terrain



Do NOT Operate a Stowed MEWP on Rough or Uneven Terrain



Do NOT Operate an Elevated MEWP Within 4ft (1.2m) of Any Drop-off or Hole



Do NOT Operate a Stowed MEWP Within 4ft (1.2m) of Any Drop-off or Hole



Do NOT Use The MEWP As a Lifting Tool or Crane



Do NOT Exceed The Maximum Allowable Manual Side Force



Do NOT Operate The MEWP Without Sufficient Clearance



Do NOT Raise The Platform Without First Checking For Obstructions



Do NOT Lower The Platform Without Checking For Obstructions



Do NOT Allow Ground Personnel Near the MEWP During Operation



Do NOT Carry Loads That Extend Beyond The Guardrails



Do NOT Operate a MEWP From Trucks, Trailers, or Similar Equipment



Do NOT Exceed The Platform Extension Deck Capacity



Do NOT Exceed The Platform Main Deck Capacity



Do NOT Climb on The MEWP



Do NOT Climb on The Guardrails



Do NOT Engage In Any Form of Horseplay



Do NOT Operate an MEWP With Tires That Are in Poor Condition



Do NOT Operate an MEWP That is Damaged or Not Functioning Properly



Do NOT Leave the MEWP With The Key In It



Do NOT Operate an MEWP While Physically Impaired



Do NOT Strike or Bump Stationary Objects With an Elevated MEWP



Do NOT Strike or Bump Stationary Objects With a Stowed MEWP

Fall Restraint Lanyard Anchor Points

All fall restraint lanyard anchor points on Snorkel aerial work platforms have been tested with a force of 3,650 lbs (16.3 kN) per person.

See below examples of anchor points used on Snorkel machines with their corresponding per person rating.

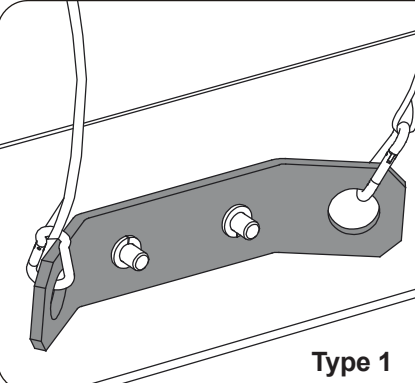
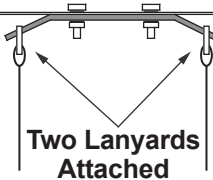
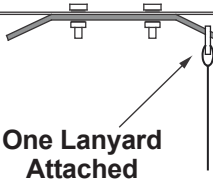
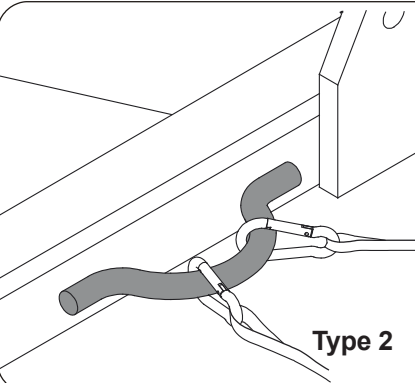
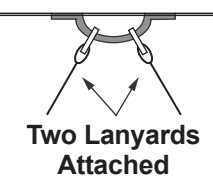
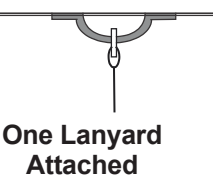
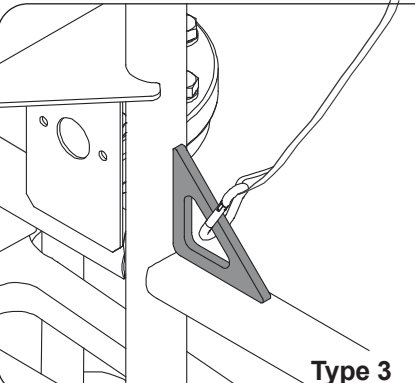
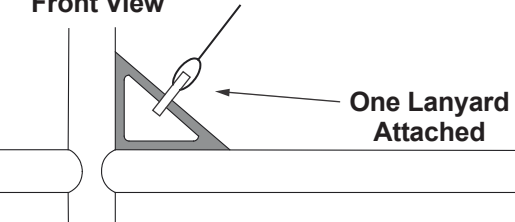
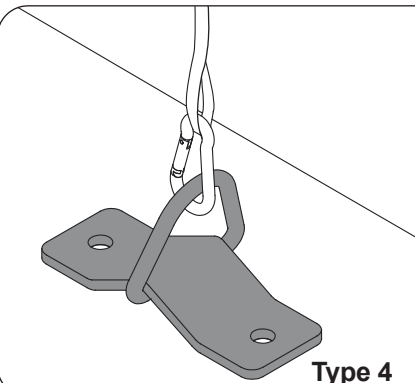
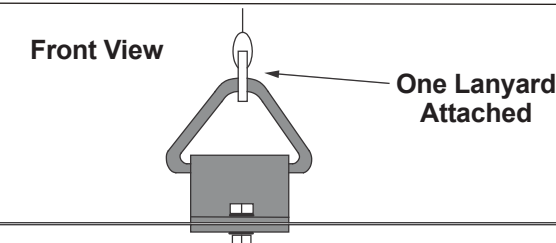
 <p>Type 1</p>	<p>Anchor point Type 1 is rated for one lanyard attachment per loop. Refer to machine "Specifications" and platform decals for maximum number of platform occupants.</p>	<p>Top View</p>  <p>Two Lanyards Attached</p>	<p>Top View</p>  <p>One Lanyard Attached</p>
 <p>Type 2</p>	<p>Anchor point Type 2 is rated for two lanyard attachments per loop. Refer to machine "Specifications" and platform decals for maximum number of platform occupants.</p>	<p>Top View</p>  <p>Two Lanyards Attached</p>	<p>Top View</p>  <p>One Lanyard Attached</p>
 <p>Type 3</p>	<p>Anchor point Type 3 is rated for one lanyard attachment per loop. Refer to machine "Specifications" and platform decals for maximum number of platform occupants.</p>	<p>Front View</p>  <p>One Lanyard Attached</p>	
 <p>Type 4</p>	<p>Anchor point Type 4 is rated for one lanyard attachment per loop. Refer to machine "Specifications" and platform decals for maximum number of platform occupants.</p>	<p>Front View</p>  <p>One Lanyard Attached</p>	

NOTE: There can be more anchor points in the platform than the maximum number of occupants allowed in the platform. Refer to the machine specifications for the correct occupancy rating before use.

SAFETY RULES

⚠Warning

All personnel shall carefully read, understand and follow all safety rules and operating instructions before operating or performing maintenance on any Snorkel aerial work platform.

Electrocution Hazard



THIS MACHINE IS NOT INSULATED!

Tip Over Hazard



NEVER elevate the platform or drive the machine while elevated unless the machine is on a firm, level surface.

Collision Hazard



NEVER position the platform without first checking for overhead obstructions or other hazards.

Fall Hazard



NEVER climb, stand, or sit on platform guardrails or midrail.

USE OF THE AERIAL WORK PLATFORM: This aerial work platform is intended to lift persons, their tools and materials used for the job. It is designed for repair, assembly, stockpicking jobs, etc., and assignments at workplaces above head height (ceilings, cranes, roof structures, buildings, shelving, etc.). All other uses of the aerial work platform are prohibited and the rules below must be adhered to!

THIS AERIAL WORK PLATFORM IS NOT INSULATED! Refer to applicable national standards for safe approach distances.

Exceeding the specified permissible maximum load **is prohibited!** See “Platform Capacity” for details.

The use and operation of the aerial work platform as a lifting tool or a crane **is prohibited!**

NEVER exceed the manual force allowed for this machine. See “Manual Force” for details.

DISTRIBUTE all platform loads evenly on the platform.

NEVER operate the machine without first surveying the work area for stationary or moving obstacles and surface hazards such as holes, drop-offs, bumps, curbs, or debris; and avoiding them. **NEVER** strike or bump into stationary or moving obstacles while driving or raising, lowering, or extending the platform.

USE THREE POINTS OF SUPPORT when entering or exiting the platform. Grasp the handrails, not the doors, with one hand on each side. Use two hands and one foot on the step when climbing into and out of the platform.

PLATFORM passengers should watch their hands and fingers for pinch points while holding on the guardrails while the platform is moving.

OPERATE machine only on surfaces capable of supporting wheel loads.

NEVER operate the machine when wind speeds exceed this machine’s wind rating. See “Beaufort Scale” for details.

Do not operate the aerial platform in windy or gusty conditions. Do not add anything to or take anything into the aerial platform that will increase the wind loading such as billboards, banners, flags, etc.

IN CASE OF EMERGENCY push EMERGENCY STOP switch to deactivate all powered functions.

IF ALARM SOUNDS while platform is elevated, STOP, carefully lower platform. Move machine to a firm, level surface.

Climbing up the railing of the platform, standing on or stepping from the platform onto buildings, steel or prefab concrete structures, etc., **is prohibited!** **NEVER** exit or enter the platform when it is elevated.

Dismantling the entry gate or other railing components **is prohibited!** Always make certain that the entry gate is closed!

It is prohibited to keep the entry gate in an open position when the platform is raised!

To extend the height or the range by placing of ladders, scaffolds or similar devices on the platform **is prohibited!**

NEVER perform service on machine while platform is elevated without blocking elevating assembly.

INSPECT the machine thoroughly for cracked welds, loose or missing hardware, hydraulic leaks, loose wire connections, and damaged cables or hoses before using.

VERIFY that all labels are in place and legible before using.

NEVER use a machine that is damaged, not functioning properly, or has damaged or missing labels.

To bypass any safety equipment **is prohibited** and presents a danger for the persons on the aerial work platform and in its working range.

NEVER charge batteries near sparks or open flame. Charging batteries emit explosive hydrogen gas.

Modifications to the aerial work platform **are prohibited** or permissible only at the approval by **Snorkel**.

AFTER USE, secure the work platform from unauthorized use by turning the keyswitch off and removing key.

The driving of MEWP’s on the public highway is subject to national traffic regulations.

Certain inherent risks remain in the operation of this machine despite utilizing proper design practices and safeguarding.

Care must be taken to ensure that the machines meets the requirements of stability during use, transportation, assembly, dismantling when out of service, testing, or foreseeable breakdowns.

In the event of an accident or breakdown see “Emergency Lowering.” Do not operate the aerial platform if it is damaged or not functioning properly. Qualified maintenance personnel must correct the problem before putting the aerial platform back into service.

Table of Contents

Electrical Danger	Inside Front Cover
Proposition 65 Warning	Inside Front Cover
Danger Symbols	Inside Front Cover
Lanyard Anchor Points	Inside Front Cover
Safety Rules	Inside Front Cover

Chapter 1 – Introduction

Aerial Platform Features	1
Options	1
Operator's Manual	1
Safety Alerts	1
Operation	1
Maintenance	2
Used Material Disposal	2
Manual of Responsibilities – ANSI	2
MEWP Safe Use – AS/NZS	2
AS/NZS 1418.10 Commissioning	2
CE Compliance	2
Additional Information	2

Chapter 2 – Specifications

Component Identification	3
General Specifications – S3215L	4
General Specifications – S3215E	5
General Specifications – S3219E	6
General Specifications – S3220E	7
General Specifications – S3226E	8
General Specifications – S4726E	9
General Specifications – S4732E	10

Chapter 3 – Safety

Electrocution Hazards	11
Minimum Safe Approach Distance – ANSI	11
Minimum Safe Approach Distance – AS/NZS	12
Platform Capacity	12
Manual Force	12
Wind Speeds	12
Prestart Inspection	12
Work Place Inspection and Practices	12
Operation	13
Tip-Over and Falling Hazards	13
Electrical System	14
Hydraulic System	14
Placards and Decals	14
General Safety Rules	14

Chapter 4 – Safety Devices

Emergency Stop Controls	17
Control Select/Ground Operation Switch	17
Upper Control Interlock Switch	17
Drive Motion Alarm	18
Pothole Protector Skids	18
Drive/Lift Pothole Protector Interlock	18
Drive/Lift Level Sensor Interlock	18
Progressive Tilt	18
Lowering Alarm	18

Emergency Lowering Lever/Handle	19
Safety Prop	19
Guardrails	19
Ground Fault Circuit Interrupter	20
Tilt Alarm	20
Overload Protection	20
Lowering Interrupt – CE/AS/NZS	20
Horn	20
Flashing Light	20
Snorkel Guard	20
Perimeter Lights	21

Chapter 5 – Gauges and Displays

Battery Charge Indicator – ProCharger	23
Battery Charge Indicator – Pylon	23
Battery Condition Indicator	23
Diagnostic Center Display	24

Chapter 6 – Batteries

General Maintenance	25
Charging	25

Chapter 7 – Controls

Battery Disconnect	27
Lower Controls	27
Emergency Stop Button	27
Control Selector/Ground Operation Switch	27
Platform Raise/Lower Switch	27
Upper Controls	28
Emergency Stop Button	28
Drive/Lift Selector Switch	28
Joystick	28
Interlock Switch	29
Steer Switch	29
Drive Range Switch	29
Horn Button	29
Battery Condition Indicator	29
Loading Controls	29
Emergency Stop Button	29
Interlock Button	30
Drive Switch	30
Steer Switch	30
Override Switch	30

Chapter 8 – Prestart Inspection

Operator's Manual	31
Electrical System	31
Battery Fluid Level	31
Battery Terminals	32
Battery Charger	32
Safety Prop	32
Cables and Wiring Harness	33
Hydraulic System	33
Fluid Level	33
Hoses, Tubes, and Fittings	33
Free-Wheeling Valve	34
Diagnostic Center Display	34
Tires and Wheels	34

Table of Contents

Ground Strap	34
Lower Control Station	34
Operating Controls	34
Emergency Stop	35
Lowering Alarm	35
Pothole Protector Interlock	35
Emergency Lowering System	36
Structures	36
Weldments	36
Rollers and Slide Blocks	37
Fasteners	37
Upper Control Station	37
Guardrail System	37
Platform Extension – Foot Activated Deck Lock ...	37
Platform Extension – Handle Lock	38
Operating Controls	39
Emergency Stop	40
Horn Button	40
Lowering Alarm	40
Drive Alarm	40
Electrical Power Outlet	40
Flashing Light	40
Perimeter Lights	41
Pipe Rack	41
Panel Carrier	41
Placards and Decals	41
Prestart Inspection Checklist	44

Chapter 9 – Operation

Preparing for Operation	45
Lower Controls	45
Upper Controls	45
Removable Upper Controls/Side Drive	46
Platform	46
Raising and Lowering	46
Lowering Interrupt – CE/AS/NZS	46
Overload Protection	47
Extending – Foot Activated Deck Lock	47
Extending – Handle Lock	48
Fold Down Guardrails	48
Driving and Steering	48
Drive Range Switch	49
Drive Speeds	49

Drive/Lift Pothole Protector Interlock	49
Drive/Lift Level Sensor Interlock	50
Progressive Tilt	50
Swing-Out Trays	50
Electrical Power Outlet	50
Pipe Rack – Top Rail Mount	51
Pipe Rack – Guardrail Mount S3219E Only	52
Panel Carrier	53
Snorkel Guard	53
Override Button	54
Snorkel OnSite	54
Perimeter Lights	54
After Use Each Day	54

Chapter 10 – Stowing and Transporting

Stowing	55
Transporting	55
Lifting With a Forklift	55
Winching	55
Driving	58
Hoisting	59
Securing for Transport	60
Storage	60

Chapter 11 – Emergency Operation

Emergency Lowering	61
Towing	61

Chapter 12 – Troubleshooting

Troubleshooting Chart	65
-----------------------------	----

Appendix A – Glossary

Appendix B – EC Declaration of Conformity

Appendix C – Inspection Checklists

Appendix D – Progressive Tilt

Limited Warranty

Chapter 1 – Introduction

Aerial Platform Features

The aerial platform is a self-propelled scissors lift that has been designed to raise personnel, their tools, and material to the workstation. The aerial platform has been designed for use on hard surface floors such as concrete.

The S3215L/S3215E/S3219E/S3220E uses a single hydraulic cylinder to raise and lower the platform. The S3226E/S4726E/S4732E machines have two hydraulic cylinders to raise and lower the platform. A hydraulic motor on each of the front drive wheels provides power to move the aerial platform.

The standard machine includes the following features:

- Proportional drive and lift up control
- Drivable at full height
- Two speed drive
- Drive motion alarm
- Non-marking tires
- Automatic pothole protection system
- Level sensor with drive/lift interlock
- Progressive tilt – June 2020 and after
- Platform overload system
- Diagnostic center display
- Battery condition indicator
- Manual lowering valve
- Lockable battery disconnect switch
- Tie-down/lifting lugs
- Heavy duty battery charger
- Swing-out hydraulic component and battery trays
- Non-slip metal platform floor
- Platform extension
- 125 volt AC electrical outlet with GFCI
- Scissor arm safety support prop
- Lowering alarm
- Lowering interrupt – CE/AS/NZS
- Horn
- Rear forklift pockets
- Saloon style entry doors
- Five year limited warranty

The aerial platform has been manufactured to conform to all applicable requirements of the following organizations.

- Occupational Safety and Health Administration (OSHA)
- American National Standards Institute (ANSI)

Options

The following options may be provided on the machine:

- Flashing light
- Perimeter lights
- Pipe rack – top rail S3215E/S3219E/S4726E/S4732E
- Pipe rack – guardrail S3219E
- Panel carrier
- Platform overload system
- Inverter
- Airline to platform
- Snorkel Guard
- Snorkel Onsite telematics

- Tray locks
- Bumpguard
- European conformity (CE) compliance
- Australian/New Zealand Standards (AS/NZS) compliance
- Canadian Standards Association (CSA) compliance

Operator's Manual

This manual provides information for safe and proper operation of the aerial platform. Some information in this manual refers to options that may or may not be on your machine. Read and understand the information in this Operator's Manual before operating the aerial platform on the job.

Additional copies of this manual may be ordered from Snorkel. Supply the model and manual part number from the front cover to assure that the correct manual will be supplied.

All information in this manual is based on the latest product information at the time of publication. Snorkel reserves the right to make product changes at any time without obligation.

Safety Alerts

A safety alert symbol is used throughout this manual to indicate danger, warning, and caution instructions. Follow these instructions to reduce the likelihood of personal injury and property damage. The terms danger, warning, and caution indicate varying degrees of personal injury or property damage that can result if the instruction is not followed.

Danger

Indicates an imminently hazardous situation which, if not avoided, will result in death or serious injury. This signal word is to be used in the most extreme situations.

Warning

Indicates a potentially hazardous situation which, if not avoided, could result in death or serious injury.

Caution

Indicates a potentially hazardous situation which, if not avoided, may result in minor or moderate injury. It may also be used to alert against unsafe practices.

Notes

Notes are used to provide special information or helpful hints to assist in aerial platform operation, but do not indicate a hazardous situation.

Operation

The aerial platform has built-in safety features and has been factory tested for compliance with Snorkel specifications and industry standards. However, any personnel lifting aerial platform can be potentially dangerous in the hands of untrained or careless operators.

Warning

The potential for an accident increases when the aerial platform is operated by personnel who are not trained and authorized. Death or serious injury could result from such accidents. Read and understand the information in this manual and on the placards and decals on the machine before operating the aerial platform on the job.

Training is essential and must be performed by a qualified person.

- Become proficient in knowledge and actual operation before using the aerial platform on the job.
- The operator must be trained and authorized to perform any functions of the aerial platform.
- Operation of the aerial platform must be within the scope of the machine specifications.

The operator bears ultimate responsibility for following all manufacturer's instructions and warnings, regulations and safety rules of their employer and/or any state or federal law.

Maintenance

Complete machine inspection consists of periodic visual and operational checks, along with periodic minor adjustments that assure proper performance. The frequency and extent of periodic inspections may depend on national regulations. Daily inspection will prevent abnormal wear and prolong the life of all systems. The inspection and maintenance schedule should be performed at the specified intervals and after prolonged periods of storage before returning the machine to service. Inspection and maintenance shall be performed by personnel who are trained and familiar with mechanical and electrical procedures.

Every person who maintains, inspects, tests, or repairs the aerial platform must be qualified to do so. Following the daily prestart inspection in this Operator's Manual will help keep the aerial platform in optimum working condition. Other maintenance functions must be performed by maintenance personnel who are qualified to work on the aerial platform.

Caution

Welding current can be very intense. Damage to electronic components may result. Connect the ground clamp as close as possible to the area being welded. Disconnect battery cables and any microprocessors and control modules before welding on the machine.

If it becomes necessary to weld aerial platform components as a method of repair, take all precautions to prevent damage to electronic circuitry and devices on the machine. This includes, but may not be limited to, disconnecting battery cables and electronic devices.

Do not modify this aerial platform without prior written consent of the Snorkel Engineering Department. Modification may void the warranty, adversely affect stability, or affect the operational characteristics of the aerial platform.

Used Material Disposal

For proper used material disposal, refer to all applicable national and/or employer standards before disposal of any environmentally sensitive material including, but not limited to, hydraulic fluid, batteries, and battery fluid.

Manual of Responsibilities – ANSI

All owners and users of the aerial platform must read, understand, and comply with all applicable regulations as stated in ANSI A92.20. Ultimate compliance to ANSI and OSHA regulations is the responsibility of the user and their employer.

ANSI publications clearly identify the responsibilities of all personnel who may be involved with the aerial platform. A reprint of the "Manual of Responsibilities for Manufacturers, Dealers, Owners, Users, Supervisors, Operators, Occupants, Lessors, Lessees and Brokers of ANSI/SIA A92.22-2020 Safe Use & ANSI/SIAA92.24-2018 Training Requirements for the Use, Operation, Inspection, Testing and Maintenance of Mobile Elevating Work Platforms (MEWP)" is available from Snorkel dealers or from the factory upon request.

Copies are also available from:
Scaffold & Access Industry Association
400 Admiral Boulevard
Kansas City, MO 64106 USA

MEWP Safe Use – AS/NZS

All owners and users of the aerial platform must read, understand, and comply with all applicable regulations as stated in AS/NZS 2550.10:2006. Ultimate compliance is the responsibility of the user and their employer.

AS/NZS 1418.10 Commissioning

Per AS/NZS 1418.10, a machine has been commissioned upon return to Snorkel of a satisfactory completed Pre-Delivery and Inspection Record (PDIR). The PDIR inspection is performed by Snorkel, or it's agent, before the machine is delivered to the customer. A completed PDIR form can be obtained, by request, from the sales agent.

CE Compliance

The aerial work platform meets and exceeds the requirements of both EN280:2015+A1:2015 and ANSI A92.20.

Additional Information

For additional information contact your local dealer or Snorkel at:

Snorkel International
P.O. Box 1160
St. Joseph, MO 64502-1160 USA
1-800-255-0317
<http://www.snorkellifts.com>

Regional contact information is located on the back cover of this manual.

Chapter 2 – Specifications

Component Identification

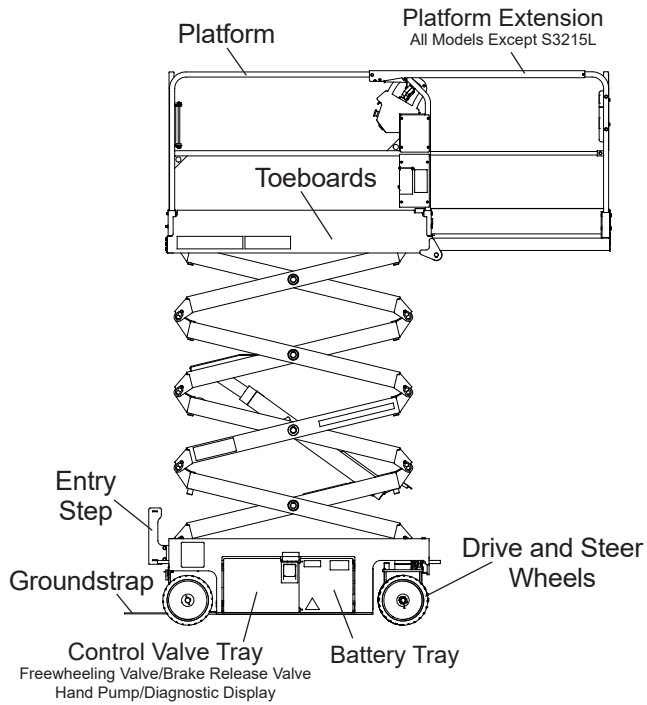

Right Side

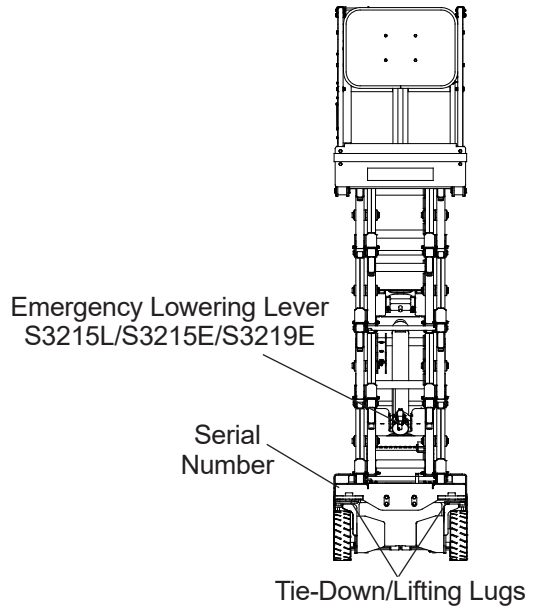

Front

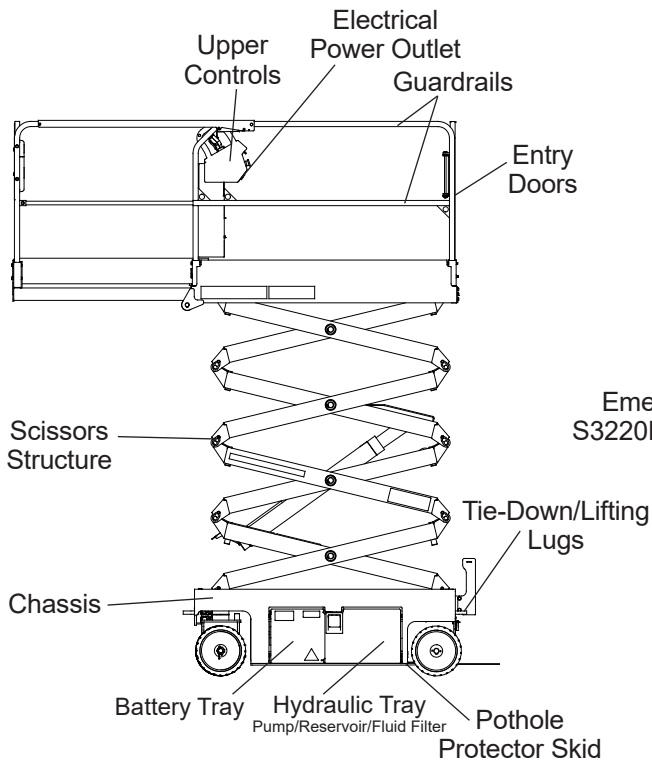

Left Side

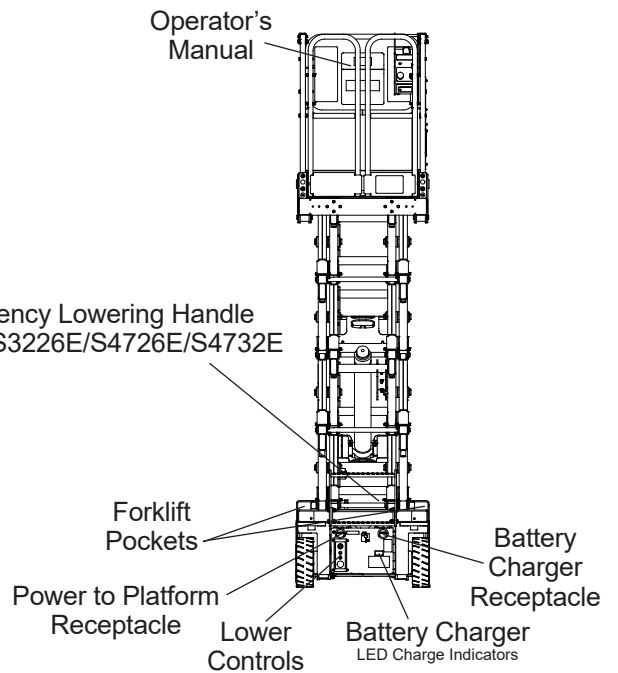

Rear

General Specifications – S3215L

Aerial Platform

Working height	21' (6.6 m)
Maximum platform height	15' (4.6 m)
Turning radius	
Inside	4" (10.16 cm)
Outside	64.25" (1.63 m)
Wheelbase	52" (1.32 m)
Ground clearance	
Pothole protector raised	2.63" (6.68 cm)
Pothole protector lowered	0.75" (1.9 cm)
Maximum wheel load	980 lbs (445.5 kg)
Maximum ground bearing pressure	115 psi (8 kg/cm ²)
Floor load pressure	195 psf (951 kg/m ²)
Tread contact patch	8.5 in ² (55.1 cm ²)
Floor area	14.2 ft ² (1.32 m ²)
Weight, EVW	
Approximate	2,100 lbs (952 kg)
Maximum allowable manual force (side pull)	
Indoors	90 lbs (400 N)
Outdoors	45 lbs (200 N)
Stowed width	32" (81.3 cm)
Stowed length	81.4" (2.07 m)
With step removed	79.4" (2.02 m)
Stowed height	76" (1.93 m)
With rails folded	65" (1.65 m)

Platform

Dimensions	28.25" x 73.5" (71.6 cm x 186.5 cm)
Guardrail height	39" (0.99 m)
Toeboard height	6" (15.2 cm)
Rated work load	
Total	670 lb (305 kg)
Maximum number of occupants	1 outdoors 2 indoors

Function Speed

Platform raise	16 to 20 seconds
Platform lower	30 to 38 seconds
High Drive	
Platform lower than 6' (1.8 m)	0 to 2 mph (0 to 3.2 km/h)
Low Drive	
Platform higher than 6' (1.8 m)	0 to 0.4 mph (0 to 0.6 km/h)

Drive System

Standard	Two-wheel drive
Gradeability	25%
Maximum drive height	15' (4.6 m)

Drive/Lift Level Sensor Interlock

Side-to-side – ANSI	2 degrees*
Side-to-side – CE/AS/NZS	1.2 degrees*
Front-to-rear	4 degrees

Tires

Nonmarking solid rubber 12" x 4" (30.5 cm x 10.2 cm)

Electrical System

Voltage	24 V DC negative chassis ground
Source	Four - 6 V 220 amp hour batteries
Fluid recommended	distilled water
Charger	25 amp
Input	120/240 V

Hydraulic System

Maximum pressure	3,300 psi (22,750 kPa)
Reservoir capacity	3 US gal (11.35 l)
System capacity	3.5 US gal (13.2 l)
Maximum operating temperature	160°F (71°C)
Hydraulic fluid recommended	
Above 10°F (-12°C)	ISO VG32
Below 10°F (-12°C)	ISO VG15

Ambient Air Temperature Operating Range

Fahrenheit	0°F to 110°F
Celsius	-18°C to 43°C

Maximum Wind Speed

Gust or steady	28 mph (12.5 m/s)
----------------	-------------------

Sound Pressure Level

At work station	below 70 dB(A)
-----------------	----------------

Group Classification

Heavy Duty – intended life	100,000 load cycles
----------------------------	---------------------

* Refer to Chapter 4 – Safety Devices, Progressive Tilt

General Specifications – S3215E

Aerial Platform

Working height	21' (6.6 m)
Maximum platform height	15' (4.6 m)
Turning radius	
Inside	4" (10.16 cm)
Outside	64.25" (1.63 m)
Wheelbase	52" (1.32 m)
Ground clearance	
Pothole protector raised	2.63" (6.68 cm)
Pothole protector lowered	0.75" (1.9 cm)
Maximum wheel load	1,450 lbs (659.1 kg)
Maximum ground bearing pressure	183 psi (12.8 kg/cm ²)
Floor load pressure	234 psf (1141 kg/m ²)
Tread contact patch	8.5 in ² (55.1 cm ²)
Floor area	14.2 ft ² (1.32 m ²)
Weight, EVW	
Approximate	2,700 lbs (1227 kg)
Maximum allowable manual force (side pull)	
Indoors	90 lbs (400 N)
Outdoors	45 lbs (200 N)
Stowed width	32" (81.3 cm)
Stowed length	70.4" (1.79 m)
With step removed	68.25" (1.73 m)
Stowed height – ANSI	76" (1.93 m)
Stowed height – CE/AS/NZS	78.75" (2 m)
With rails folded	61.5" (1.56 m)

Platform

Dimensions	28.25" x 63.75" (71.6 cm x 161.9 cm)
Extension	28.25" x 36" (71.6 cm x 91.4 cm)
Total length with extension	99.75" (253.4 cm)
Guardrail height – ANSI	39" (0.99 m)
Guardrail height – CE/AS/NZS	43.3" (1.1 m)
Toeboard height	6" (15.2 cm)
Rated work load	
Total	600 lb (273 kg)
Extension	250 lb (113 kg)
Maximum number of occupants	1 outdoors 2 indoors

Function Speed

Platform raise	16 to 20 seconds
Platform lower	30 to 36 seconds
High Drive	
Platform lower than 6' (1.8 m)	0 to 2 mph (0 to 3.2 km/h)
Low Drive	
Platform higher than 6' (1.8 m)	0 to 0.4 mph (0 to 0.6 km/h)

Drive System

Standard	Two-wheel drive
Gradeability	25%
Maximum drive height	15' (4.6 m)

Drive/Lift Level Sensor Interlock

Side-to-side – ANSI	2 degrees*
Side-to-side – CE/AS/NZS	1.5 degrees*
Front-to-rear	4 degrees

Tires

Nonmarking solid rubber	12" x 4" (30.5 cm x 10.2 cm)
-------------------------	------------------------------

Electrical System

Voltage	24 V DC negative chassis ground
Source	Four - 6 V 220 amp hour batteries
Fluid recommended	distilled water
Charger	25 amp
Input	120/240 V

Hydraulic System

Maximum pressure	3,300 psi (22,750 kPa)
Reservoir capacity	3 US gal (11.35 l)
System capacity	3.5 US gal (13.2 l)
Maximum operating temperature	160°F (71°C)
Hydraulic fluid recommended	
Above 10°F (-12°C)	ISO VG32
Below 10°F (-12°C)	ISO VG15

Ambient Air Temperature Operating Range

Fahrenheit	0°F to 110°F
Celsius	-18°C to 43°C

Maximum Wind Speed

Gust or steady	28 mph (12.5 m/s)
----------------	-------------------

Vibration

Hand/arm	less than 2.5 m/sec ²
Body	less than 0.5 m/sec ²

Sound Pressure Level

At work station	below 70 dB(A)
-----------------	----------------

Group Classification

Heavy Duty – intended life	100,000 load cycles
----------------------------	---------------------

* Refer to Chapter 4 – Safety Devices, Progressive Tilt

General Specifications – S3219E

Aerial Platform

Working height	25' (7.6 m)
Maximum platform height	19' (5.8 m)
Turning radius	
Inside	4" (10.16 cm)
Outside	64.25" (1.63 m)
Wheelbase	52" (1.32 m)
Ground clearance	
Pothole protector raised	2.63" (6.68 cm)
Pothole protector lowered	0.75" (1.9 cm)
Maximum wheel load	1,450 lbs (659.1 kg)
Maximum ground bearing pressure	
	175 psi (12.3 kg/cm ²)
Floor load pressure – ANSI	250 psf (1221 kg/m ²)
Floor load pressure – CE/AS/NZS	300 psf (1465 kg/m ²)
Tread contact patch	8.5 in ² (55.1 cm ²)
Floor area	14.2 ft ² (1.32 m ²)
Weight, EVW – ANSI	
Approximate	2,900 lbs (1318 kg)
Weight, EVW – CE/AS/NZS	
Approximate	3,550 lbs (1614 kg)
Maximum allowable manual force (side pull)	
Indoors	90 lbs (400 N)
Outdoors	45 lbs (200 N)
Stowed width	32" (81.3 cm)
Stowed length	70.4" (1.79 m)
With step removed	68.25" (1.73 m)
Stowed height – ANSI	79.25" (2.01 m)
Stowed height – CE/AS/NZS	82.3" (2.09 m)
With rails folded	65" (1.65 m)

Platform

Dimensions	
Main	28.25" x 63.75" (71.6 cm x 161.9 cm)
Extension	28.25" x 36" (71.6 cm x 91.4 cm)
Total length with extension	99.75" (253.4 cm)
Guardrail height – ANSI	39" (0.99 m)
Guardrail height – CE/AS/NZS	43.3" (1.1 m)
Toeboard height	6" (15.2 cm)
Rated work load	
Total	550 lb (250 kg)
Extension	250 lb (113 kg)
Maximum number of occupants	1 outdoors 2 indoors

Function Speed

Platform raise	16 to 20 seconds
Platform lower	30 to 36 seconds
High Drive	
Platform lower than 6' (1.8 m)	0 to 2 mph (0 to 3.2 km/h)
Low Drive	
Platform higher than 6' (1.8 m)	0 to 0.4 mph (0 to 0.6 km/h)

Drive System

Standard	Two-wheel drive
Gradeability	25%
Maximum drive height	19' (5.8 m)

Drive/Lift Level Sensor Interlock

Side-to-side – ANSI	2 degrees*
Side-to-side – CE/AS/NZS	1.5 degrees*
Front-to-rear	4 degrees

Tires

Nonmarking solid rubber 12" x 4" (30.5 cm x 10.2 cm)

Electrical System

Voltage	24 V DC negative chassis ground
Source	Four - 6 V 220 amp hour batteries
Fluid recommended	distilled water
Charger	25 amp
Input	120/240 V

Hydraulic System

Maximum pressure	3,300 psi (22,750 kPa)
Reservoir capacity	3 US gal (11.35 l)
System capacity	3.5 US gal (13.2 l)
Maximum operating temperature	160°F (71°C)
Hydraulic fluid recommended	
Above 10°F (-12°C)	ISO VG32
Below 10°F (-12°C)	ISO VG15

Ambient Air Temperature Operating Range

Fahrenheit	0°F to 110°F
Celsius	-18°C to 43°C

Maximum Wind Speed

Gust or steady	28 mph (12.5 m/s)
----------------	-------------------

Vibration

Hand/arm	less than 2.5 m/sec ²
Body	less than 0.5 m/sec ²

Sound Pressure Level

At work station	below 70 dB(A)
-----------------	----------------

Group Classification

Heavy Duty – intended life	100,000 load cycles
----------------------------	---------------------

* Refer to Chapter 4 – Safety Devices, Progressive Tilt

General Specifications – S3220E

Aerial Platform

Working height	26' (8.1 m)
Maximum platform height	20' (6.1 m)
Turning radius	
Inside	30" (76.2 cm)
Outside	93" (2.36 m)
Wheelbase	69.72" (1.77 m)
Ground clearance	
Pothole protector raised	3.75" (9.53 cm)
Pothole protector lowered	0.75" (1.9 cm)
Maximum wheel load	2,050 lbs (932 kg)
Maximum ground bearing pressure	215 psi (15 kg/cm ²)
Floor load pressure	287 psf (1400 kg/m ²)
Tread contact patch	9.6 in ² (61.6 cm ²)
Floor area	18.8 ft ² (1.75 m ²)
Weight, EVW	
Approximate	4,500 lbs (2045 kg)
Maximum allowable manual force (side pull)	
Indoors	90 lbs (400 N)
Outdoors	45 lbs (200 N)
Stowed width	32" (81.3 cm)
Stowed length	90.6" (2.3 m)
With step removed	88.7" (2.25 m)
Stowed height	85.25" (2.16 m)
With rails folded	67.75" (1.72 m)

Platform

Dimensions	
Main	28.25" x 84.38" (71.6 cm x 214.3 cm)
Extension	28.25" x 36" (71.6 cm x 91.4 cm)
Total length with extension	102.38" (305.8 cm)
Guardrail height	43.3" (1.1 m)
Toeboard height	6" (15.2 cm)
Rated work load	
Total	900 lb (409 kg)
Extension	250 lb (113 kg)
Maximum number of occupants	1 outdoors 2 indoors

Function Speed

Platform raise	30 to 34 seconds
Platform lower	37 to 43 seconds
High Drive	
Platform lower than 6' (1.8 m)	0 to 2 mph (0 to 3.2 km/h)
Low Drive	
Platform higher than 6' (1.8 m)	0 to 0.4 mph (0 to 0.6 km/h)

Drive System

Standard	Two-wheel drive
Gradeability	25%
Maximum drive height	20' (6.1 m)

Drive/Lift Level Sensor Interlock

Side-to-side – ANSI	2 degrees*
Side-to-side – CE/AS/NZS	1.5 degrees*
Front-to-rear	4 degrees

Tires

Nonmarking solid rubber	15" x 4" (38.1 cm x 10.2 cm)
-------------------------	------------------------------

Electrical System

Voltage	24 V DC negative chassis ground
Source	Four - 6 V 240 amp hour batteries
Fluid recommended	distilled water
Charger	25 amp
Input	120/240 V

Hydraulic System

Maximum pressure	3,300 psi (22,750 kPa)
Reservoir capacity	4.5 US gal (17 l)
System capacity	5 US gal (19 l)
Maximum operating temperature	160°F (71°C)
Hydraulic fluid recommended	
Above 10°F (-12°C)	ISO VG32
Below 10°F (-12°C)	ISO VG15

Ambient Air Temperature Operating Range

Fahrenheit	0°F to 110°F
Celsius	-18°C to 43°C

Maximum Wind Speed

Gust or steady	28 mph (12.5 m/s)
----------------	-------------------

Vibration

Hand/arm	less than 2.5 m/sec ²
Body	less than 0.5 m/sec ²

Sound Pressure Level

At work station	below 70 dB(A)
-----------------	----------------

Group Classification

Heavy Duty – intended life	100,000 load cycles
----------------------------	---------------------

* Refer to Chapter 4 – Safety Devices, Progressive Tilt

General Specifications – S3226E

Aerial Platform

Working height	32' (9.8 m)
Maximum platform height	26' (7.9 m)
Turning radius	
Inside	30" (76.2 cm)
Outside	93" (2.36 m)
Wheelbase	69.72" (1.77 m)
Ground clearance	
Pothole protector raised	3.75" (9.53 cm)
Pothole protector lowered	0.75" (1.9 cm)
Maximum wheel load – ANSI	2,050 lbs (932 kg)
Maximum wheel load – CE/AS/NZS	1,550 lbs (705 kg)
Maximum ground bearing pressure – ANSI	240 psi (16.8 kg/cm ²)
Maximum ground bearing pressure – CE/AS/NZS	175 psi (12.3 kg/cm ²)
Floor load pressure – ANSI	315 psf (1538 kg/m ²)
Floor load pressure – CE/AS/NZS	290 psf (1416 kg/m ²)
Tread contact patch	8.3 in ² (53.6 cm ²)
Floor area	18.8 ft ² (1.75 m ²)
Weight, EVW – ANSI	
Approximate	5,000 lbs (2273 kg)
Weight, EVW – CE/AS/NZS	
Approximate	4,500 lbs (2045 kg)
Maximum allowable manual force (side pull)	
Indoors	90 lbs (400 N)
Outdoors	45 lbs (200 N)
Stowed width	32" (81.3 cm)
Stowed length	90.6" (2.3 m)
With step removed	88.7" (2.25 m)
Stowed height	90.6" (2.30 m)
With rails folded	73.13" (1.86 m)

Platform

Dimensions	
Main	28.5" x 84.38" (71.6 cm x 214.3 cm)
Extension	28.25" x 36" (71.6 cm x 91.4 cm)
Total length with extension	102.38" (305.8 cm)
Guardrail height	43.3" (1.1 m)
Toeboard height	6" (15.2 cm)
Rated work load	
Total	550 lb (250 kg)
Extension	250 lb (113 kg)
Maximum number of occupants	1 outdoors 2 indoors

Function Speed

Platform raise	46 to 50 seconds
Platform lower	50 to 56 seconds
High Drive	
Platform lower than 6' (1.8 m)	0 to 2 mph (0 to 3.2 km/h)
Low Drive	
Platform higher than 6' (1.8 m)	0 to 0.4 mph (0 to 0.6 km/h)

Drive System

Standard	Two-wheel drive
Gradeability	25%
Maximum drive height	26' (7.9 m)

Drive/Lift Level Sensor Interlock

Side-to-side	1.5 degrees*
Front-to-rear	4 degrees

Tires

Nonmarking solid rubber	15" x 4" (38.1 cm x 10.2 cm)
-------------------------	------------------------------

Electrical System

Voltage	24 V DC negative chassis ground
Source	Four - 6 V 240 amp hour batteries
Fluid recommended	distilled water
Charger	25 amp
Input	120/240 V

Hydraulic System

Maximum pressure	3,300 psi (22,750 kPa)
Reservoir capacity	4.5 US gal (17 l)
System capacity	5 US gal (19 l)
Maximum operating temperature	160°F (71°C)
Hydraulic fluid recommended	
Above 10°F (-12°C)	ISO VG32
Below 10°F (-12°C)	ISO VG15

Ambient Air Temperature Operating Range

Fahrenheit	0°F to 110°F
Celsius	-18°C to 43°C

Maximum Wind Speed

Gust or steady	28 mph (12.5 m/s)
----------------	-------------------

Vibration

Hand/arm	less than 2.5 m/sec ²
Body	less than 0.5 m/sec ²

Sound Pressure Level

At work station	below 70 dB(A)
-----------------	----------------

Group Classification

Heavy Duty – intended life	100,000 load cycles
----------------------------	---------------------

* Refer to Chapter 4 – Safety Devices, Progressive Tilt

General Specifications – S4726E

Aerial Platform

Working height	32' (9.8 m)
Maximum platform height	26' (7.9 m)
Turning radius	
Inside	21" (53.3 cm)
Outside	95" (2.41 m)
Wheelbase	69.72" (1.77 m)
Ground clearance	
Pothole protector raised	2.63" (6.68 cm)
Pothole protector lowered	0.75" (1.9 cm)
Maximum wheel load	2,540 lbs (1155 kg)
Maximum ground bearing pressure	
190 psi (13.3 kg/cm ²)	
Floor load pressure	210 psf (1025 kg/m ²)
Tread contact patch	9 in ² (58.1 cm ²)
Floor area	27.7 ft ² (2.57 m ²)
Weight, EVW – ANSI	
Approximate	4,750 lbs (2159 kg)
Weight, EVW – CE/AS/NZS	
Approximate	4,950 lbs (2250 kg)
Maximum allowable manual force (side pull)	
Indoors	90 lbs (400 N)
Outdoors	45 lbs (200 N)
Stowed width	47" (1.20 m)
Stowed length	90.6" (2.30 m)
With step removed	88.7" (2.25 m)
Stowed height	90.2" (2.29 m)
With rails folded	72.88" (1.85 m)

Platform

Dimensions	
Main	43" x 84.38" (109.2 cm x 214.3 cm)
Extension	43" x 48" (109.2 cm x 121.9 cm)
Total length with extension	132.38" (336.2 cm)
Guardrail height	43.3" (1.1 m)
Toeboard height	6" (15.2 cm)
Rated work load	
Total	1,000 lb (455 kg)
Extension	250 lb (113 kg)
Maximum number of occupants	1 outdoors
ANSI	3 indoors
CE/AS/NZS	2 indoors

Function Speed

Platform raise	46 to 50 seconds
Platform lower	52 to 58 seconds
High Drive	
Platform lower than 6' (1.8 m)	0 to 2 mph (0 to 3.2 km/h)
Low Drive	
Platform higher than 6' (1.8 m)	0 to 0.4 mph (0 to 0.6 km/h)

Drive System

Standard	Two-wheel drive
Gradeability	25%
Maximum drive height	26' (7.9 m)

Drive/Lift Level Sensor Interlock

Side-to-side – ANSI	2 degrees*
Side-to-side – CE/AS/NZS	1.5 degrees*
Front-to-rear – ANSI	4 degrees*
Front-to-rear – CE/AS/NZS	3.5 degrees*

Tires

Nonmarking solid rubber	15" x 5" (38.1 cm x 12.7 cm)
-------------------------	------------------------------

Electrical System

Voltage	24 V DC negative chassis ground
Source	Four - 6 V 240 amp hour batteries
Fluid recommended	distilled water
Charger	25 amp
Input	120/240 V

Hydraulic System

Maximum pressure	3,300 psi (22,750 kPa)
Reservoir capacity	4.5 US gal (17 l)
System capacity	5 US gal (19 l)
Maximum operating temperature	160°F (71°C)
Hydraulic fluid recommended	
Above 10°F (-12°C)	ISO VG32
Below 10°F (-12°C)	ISO VG15

Ambient Air Temperature Operating Range

Fahrenheit	0°F to 110°F
Celsius	-18°C to 43°C

Maximum Wind Speed

Gust or steady	28 mph (12.5 m/s)
----------------	-------------------

Vibration

Hand/arm	less than 2.5 m/sec ²
Body	less than 0.5 m/sec ²

Sound Pressure Level

At work station	below 70 dB(A)
-----------------	----------------

Group Classification

Heavy Duty – intended life	100,000 load cycles
----------------------------	---------------------

* Refer to Chapter 4 – Safety Devices, Progressive Tilt

General Specifications – S4732E

Aerial Platform

Working height	38' (11.6 m)
Maximum platform height	32' (9.8 m)
Turning radius	
Inside	21" (53.3 cm)
Outside	95" (2.41 m)
Wheelbase	69.72" (1.77 m)
Ground clearance	
Pothole protector raised	2.63" (6.68 cm)
Pothole protector lowered	0.75" (1.9 cm)
Maximum wheel load	2,730 lbs (1241 kg)
Maximum ground bearing pressure – ANSI	
325 psi (15.8 kg/cm ²)	
Maximum ground bearing pressure – CE/AS/NZS	
245 psi (17.2kg/cm ²)	
Floor load pressure – ANSI	250 psf (1221 kg/m ²)
Floor load pressure – CE/AS/NZS	260 psf (1269 kg/m ²)
Tread contact patch	9.0 in ² (58.2 cm ²)
Floor area	27.7 ft ² (2.57 m ²)
Weight, EVW – ANSI	
Approximate	5,700 lbs (2591 kg)
Weight, EVW – CE/AS/NZS	
Approximate	5,925 lbs (2693 kg)
Maximum allowable manual force (side pull)	
Indoors	90 lbs (400 N)
Outdoors	45 lbs (200 N)
Stowed width	47" (1.20 m)
Stowed length	90.6" (2.30 m)
With step removed	88.7" (2.25 m)
Stowed height	94.2" (2.39 m)
With rails folded	76.88" (1.95 m)

Platform

Dimensions	
Main	43" x 84.38" (109.2 cm x 214.3 cm)
Extension	43" x 48" (109.2 cm x 121.9 cm)
Total length with extension	132.38" (336.2 cm)
Guardrail height	43.3" (1.1 m)
Toeboard height	6" (15.2 cm)
Rated work load	
Total – ANSI	700 lb (318 kg)
Total – CE/AS/NZS	770 lb (350 kg)
Total – CE/AS/NZS Option	700 lb (318 kg)**
Extension	250 lb (113 kg)
Maximum number of occupants	1 outdoors 2 indoors

Function Speed

Platform raise	46 to 50 seconds
Platform lower	52 to 58 seconds
High Drive	
Platform lower than 6' (1.8 m)	0 to 2 mph (0 to 3.2 km/h)
Low Drive	
Platform higher than 6' (1.8 m)	0 to 0.4 mph (0 to 0.6 km/h)

Drive System

Standard	Two-wheel drive
Gradeability	25%
Maximum drive height	32' (9.8 m)

Drive/Lift Level Sensor Interlock

Side-to-side – ANSI	2 degrees*
Side-to-side – CE/AS/NZS	1.5 degrees*
Front-to-rear	4 degrees

Tires

Nonmarking solid rubber 15" x 5" (38.1 cm x 12.7 cm)

Electrical System

Voltage	24 V DC negative chassis ground
Source	Four - 6 V 240 amp hour batteries
Fluid recommended	distilled water
Charger	25 amp
Input	120/240 V

Hydraulic System

Maximum pressure	3,300 psi (22,750 kPa)
Reservoir capacity	4.5 US gal (17 l)
System capacity	5 US gal (19 l)
Maximum operating temperature	160°F (71°C)
Hydraulic fluid recommended	
Above 10°F (-12°C)	ISO VG32
Below 10°F (-12°C)	ISO VG15

Ambient Air Temperature Operating Range

Fahrenheit	0°F to 110°F
Celsius	-18°C to 43°C

Maximum Wind Speed

Gust or steady	28 mph (12.5 m/s)
----------------	-------------------

Vibration

Hand/arm	less than 2.5 m/sec ²
Body	less than 0.5 m/sec ²

Sound Pressure Level

At work station	below 70 dB(A)
-----------------	----------------

Group Classification

Heavy Duty – intended life	100,000 load cycles
----------------------------	---------------------

* Refer to Chapter 4 – Safety Devices, Progressive Tilt

** Refer to Serial Number placard at rear of machine.

Chapter 3 – Safety

Knowledge of the information in this manual, and proper training, provide a basis for safely operating the aerial platform. Know the location of all controls and how they operate to act quickly and responsibly in an emergency.

Safety devices reduce the likelihood of an accident.

- Never disable, modify, or ignore any safety device.
- Safety alerts in this manual indicate situations where accidents may occur.

If any malfunction, hazard or potentially unsafe condition relating to capacity, intended use, or safe operation is suspected, stop aerial platform operation and seek assistance.

The operator bears ultimate responsibility for following all manufacturer's instructions and warnings, regulations and safety rules of their employer and/or any state or federal law.

Electrocution Hazards

The aerial platform is made of metal components and is not insulated. Regard all conductors as energized. Do not operate outside during a thunderstorm.

Minimum Safe Approach Distance – ANSI
Minimum safe approach distances to energized power lines and their associated parts must be observed while operating the aerial platform.

⚠ Danger

The aerial platform is not electrically insulated. Death or serious injury will result from contact with, or inadequate clearance from, an energized conductor. Do not go closer than the minimum safe approach distance as defined by ANSI.

ANSI publications define minimum distances that must be observed when working near bus bars and energized power lines. Table 1 and Figure 3 are reprinted courtesy of Scaffold Industry Association, ANSI/SIA A92.6.

Voltage Range (Phase to Phase)	Minimum Safe Approach Distance	
	Feet	Meters
0 to 300V	Avoid Contact	
Over 300V to 50kV	10	3.05
Over 50kV to 200kV	15	4.60
Over 200kV to 350kV	20	6.10
Over 350kV to 500kV	25	7.62
Over 500kV to 750kV	35	10.67
Over 750kV to 1000kV	45	13.72

Table 1 – Minimum Safe Approach Distance

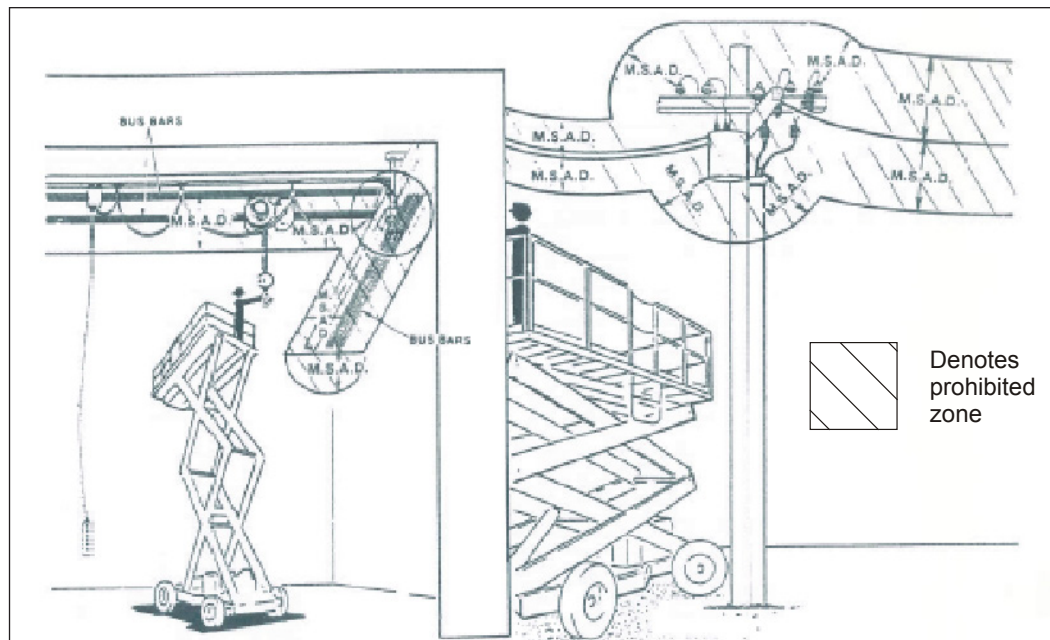

Figure 3 – Minimum Safe Approach Distance

Minimum Safe Approach Distance – AS/NZS

Minimum safe approach distances to energized power lines and their associated parts must be observed while operating the aerial platform.

⚠ Danger

The aerial platform is not electrically insulated. Death or serious injury will result from contact with, or inadequate clearance from, an energized conductor. Do not go closer than the minimum safe approach distance as defined by national safety regulations.

AS/NZS 2550.10:2006 define minimum distances that must be observed when working near overhead power lines on poles and overhead power lines on towers. Refer to the clearance requirements decals on the machine to determine safe approach distances (refer to Figure 1).

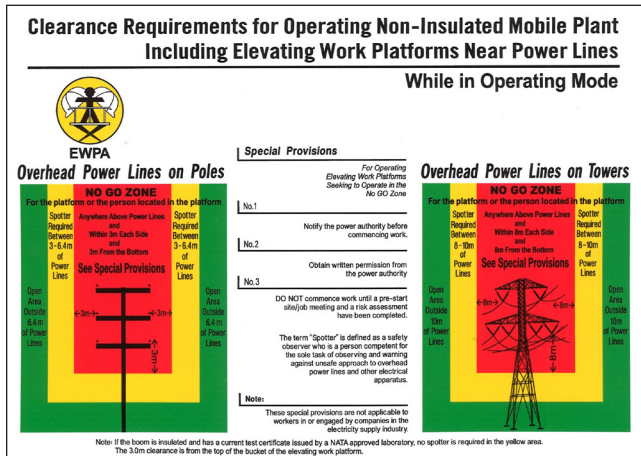

Figure 1 – Minimum Safe Approach Distance

Platform Capacity

The maximum unrestricted rated load capacity and the maximum number of occupants for the aerial platform are stated on machine decals, placards, and in the machine specifications in this manual.

⚠ Danger

The aerial platform can tip over if it becomes unstable. Death or serious injury will result from a tip-over accident. Do not exceed the capacity values indicated on the machine decals, placards, and in the machine specifications in this manual.

BEAUFORT RATING	WIND SPEED				GROUND CONDITIONS
	m/s	km/h	ft/s	mph	
3	3,4~5,4	12,25~19,4	11.5~17.75	7.5~12.0	Papers and thin branches move, flags wave.
4	5,4~8,0	19,4~28,8	17.75~26.25	12.0~18	Dust is raised, paper whirls up, and small branches sway.
5	8,0~10,8	28,8~38,9	26.25~35.5	18~24.25	Shrubs with leaves start swaying. Wave crests are apparent in ponds or swamps.
6	10,8~13,9	38,9~50,0	35.5~45.5	24.5~31	Tree branches move. Power lines whistle. It is difficult to open an umbrella.
7	13,9~17,2	50,0~61,9	45.5~56.5	31.~38.5	Whole trees sway. It is difficult to walk against the wind.

Figure 2 – Beaufort Scale

Manual Force

Manual force is the force applied by the occupants to objects such as walls or other structures outside the work platform.

⚠ Danger

The aerial platform can tip over if it becomes unstable. Death or serious injury will result from a tip-over accident. Do not exceed the maximum allowable manual force indicated on the machine decals, placards, and in the machine specifications in this manual.

The maximum allowable manual force is limited to 45 lbs (200 N) of force per occupant, with a maximum of 90 lbs (400 N) for all occupants.

Wind Speeds

Do not add anything to the aerial platform that will increase the wind loading such as billboards, banners, flags, etc.

⚠ Danger

The aerial platform can tip over if it becomes unstable. Death or serious injury will result from a tip-over accident. Do not operate the machine in wind speeds of 28 mph (12.5 m/s) or greater.

Do not operate the aerial platform in windy conditions with wind gusts or steady wind speeds of 28 mph (12.5 m/s) or greater. Refer to Figure 2.

Prestart Inspection

Perform a prestart inspection before each shift as described in Chapter 8. Do not use the aerial platform on the job unless you are trained and authorized to do so.

Work Place Inspection and Practices

Do not use the aerial platform as a ground connection when welding.

- The welding ground clamp must be attached to the same structure that is being welded.
- Electrical current flow can be very intense, causing serious internal damage to some components.

Inspect the area before and during aerial platform use. The following are some potential hazards that may be in the work place:

- Debris
- Slopes
- Drop-offs or holes
- Bumps and floor obstructions
- Overhead obstructions
- Unauthorized persons
- High voltage conductors
- Wind and weather conditions
- Inadequate surface and support to withstand load forces applied by the aerial platform in all operating configurations

Before using the aerial platform in any hazardous (classified) location, make certain it is approved and of the type required by ANSI/NFPA 505 for use in that particular location.

Know and understand the job site traffic-flow patterns and obey the flagmen, road signs and signals.

While operating the aerial platform, a good safety practice is to have qualified personnel in the immediate work area to:

- Help in case of an emergency
- Operate emergency controls as required
- Watch for loss of control by platform operator
- Warn the operator of any obstructions or hazards that may not be obvious to them
- Watch for soft terrain, sloping surfaces, drop-offs, etc. where stability could be jeopardized
- Watch for bystanders and never allow anyone to be under, or to reach through the scissors structure while operating the aerial platform

Danger

Pinch points may exist between moving components. Death or serious injury will result from becoming trapped between components, buildings, structures, or other obstacles. Make sure there is sufficient clearance around the machine before moving the chassis or platform. Allow sufficient room and time to stop movement to avoid contact with structures or other hazards.

Always look in the direction of movement.

- Drive with care and at speeds compatible with the work place conditions.
- Use caution when driving over rough ground, on slopes and when turning.
- Do not engage in any form of horseplay or permit riders any place other than in the platform.

Secure all accessories, containers, tools and other materials in the platform to prevent them from accidentally falling or being kicked off the platform. Remove all objects that do not belong in or on the aerial platform.

Never steady the platform by positioning it against another platform.

Warning

The potential for an accident increases when operating an aerial platform that is damaged or malfunctioning. Death or serious injury could result from such accidents. Do not operate the aerial platform if it is damaged or malfunctioning.

Do not operate the aerial platform if it is damaged or not functioning properly. Qualified maintenance personnel must correct the problem before putting the aerial platform back into service.

Operation

Use three points of support when entering or exiting the platform. Grasp the handrails, not the doors, with one hand on each side. Use two hands and one foot on the step when climbing into and out of the platform.

Make sure the area below the platform is free of personnel before lowering.

Keep both feet positioned firmly on the platform floor.

- Operate the controls slowly and deliberately to avoid jerky and erratic operation.
- Always stop the controls in neutral before going in the opposite direction.

Do not dismount while the aerial platform is in motion or jump off the platform.

Properly stow the aerial platform and secure it against unauthorized operation at the end of each work day, before transporting, or if it is left unattended.

Tip-Over and Falling Hazards

Operate the aerial platform only on a firm, flat, level surface capable of withstanding all load forces imposed by the aerial platform in all operating conditions. Refer to the General Specifications chart for the maximum wheel load and drive/lift level sensor interlock information. Raise the platform only when the aerial platform is on level ground.

Danger

The aerial platform can tip over if it becomes unstable. Death or serious injury will result from a tip-over accident. Do not drive or position the aerial platform for elevated use near any drop-off, hole, slope, soft or uneven ground, or other tip-over hazard. Do not raise the platform outdoors in wind speeds above 28 mph (12.5 m/s).

Do not operate the aerial platform within 4' (1.2 m) of any drop-off or hole.

Do not raise the platform in winds above 28 mph (12.5 m/s). Do not add anything to the aerial platform that will increase the wind loading such as billboards, banners, flags, etc.

It is best not to transfer from the platform to another structure or from the structure to the platform, unless that is the safest way to do the job. Judge each situation separately taking the work environment into account. If it is necessary to transfer from the platform to another structure the following guidelines apply:

1. If you are using a fall restraint, transfer your anchorage from one structure to the other before stepping across.
2. Remember that you might be transferring to a structure where *personal fall arrest* is required.
3. Use the platform entrance, do not climb over or through the guardrails.

Never operate the aerial platform without all parts of the guardrail system in place and the entry doors closed. Make sure that all protective guards, cowlings, and doors are securely fastened.

Do not exceed the platform capacity nor the platform-extension capacity as indicated on the platform rating placard on the platform. Do not carry loads that extend beyond the platform guardrails without prior written consent from Snorkel.

Do not operate the aerial platform from trucks, trailers, railway cars, floating vessels, scaffolds, or similar equipment unless the application is approved in writing by Snorkel.

Do not use the aerial platform as a crane, hoist, jack or for any purpose other than to position personnel, tools, and materials.

Do not climb on the guardrails or use ladders, planks, or other devices to extend or increase the work position from the platform.

Take care to prevent rope, electrical cords, and hoses, etc., from becoming caught in or on the aerial platform.

- If the platform or scissors structure becomes caught on an adjacent structure or other obstacle and is prevented from normal motion, reverse the control to free the platform.
- If control reversal does not free the platform, evacuate the platform before attempting to free it.

Electrical System

Charge the batteries in a well-ventilated area free of flame, sparks, or other hazards that might cause fire or explosion.

Do not operate any of the aerial platform functions while the battery charger is plugged in.

Warning

Batteries give off hydrogen and oxygen that can combine explosively. Death or serious injury could result from a chemical explosion. Do not smoke or permit open flames or sparks when checking the batteries.

Battery acid can damage the skin and eyes. Serious infection or reaction could result if medical treatment is not given immediately. Wear face and eye protection when working near the batteries. Thoroughly rinse away any spilled fluid with clean water.

- Batteries contain sulfuric acid that can damage your eyes or skin on contact.
- Wear a face shield, rubber gloves, and protective clothing when working around batteries.
- If acid contacts your eyes, flush immediately with clear water and get medical attention.
- If acid contacts your skin, wash off immediately with clear water.

Hydraulic System

The hydraulic system contains hoses with hydraulic fluid under pressure.

Danger

Hydraulic fluid escaping under pressure can have enough force to inject fluid into the flesh. Serious infection or reaction will result if medical treatment is not given immediately. In case of injury by escaping hydraulic fluid, seek medical attention at once.

Do not place your hand or any part of your body in front of escaping hydraulic fluid. Use a piece of cardboard or wood to search for hydraulic leaks.

Placards and Decals

The aerial platform is equipped with placards and decals that provide instruction for operation and accident prevention. Do not operate the aerial platform if any placards or decals are missing, damaged, or illegible.

General Safety Rules

This aerial work platform is intended to lift persons, their tools and materials used for the job. It is designed for repair, assembly, and assignments at workplaces above head height (ceilings, cranes, roof structures, buildings, etc.). Uses or alterations to the aerial work platform must be approved by Snorkel.

This aerial work platform is not insulated. Refer to applicable national/governmental/local regulations for safe approach distances.

Exceeding the specified permissible maximum load is prohibited.

The use and operation of the aerial work platform as a lifting tool or a crane is prohibited.

Never exceed the manual force allowed for this machine.

Distribute all platform loads evenly on the platform.

Never operate the machine without first surveying the work area for stationary or moving obstacles and surface hazards such as holes, drop-offs, bumps, curbs, or debris; and avoiding them. Never strike or bump into stationary or moving obstacles while driving or raising and lowering the platform.

Use three points of support when entering or exiting the platform. Grasp the handrails, not the doors, with one hand on each side. Use two hands and one foot on the step when climbing into and out of the platform.

Platform passengers should watch their hands and fingers for pinch points while holding on the guardrails while the platform is moving.

Operate machine only on surfaces capable of supporting wheel loads.

Never operate the machine when wind speeds exceed the machine's wind rating.

Do not operate the aerial platform in windy or gusty conditions. Do not add anything to the aerial platform that will increase the wind loading such as billboards, banners, flags, etc.

In case of an emergency, push the emergency stop button to deactivate all powered functions.

If an alarm sounds while the platform is elevated, stop and carefully lower platform. Move the machine to a firm, level surface.

Climbing up the railing of the platform, standing on or stepping from the platform onto buildings, steel or precast concrete structures, etc., is prohibited. Never exit or enter the platform when it is elevated.

For AS/NZS operators, no person shall access or egress from the platform in the elevated position (except in an emergency) unless the requirements of AS2550.10 have been met. For full requirements refer directly to AS2550.10

Dismantling the entry gate or other railing components is prohibited. Always make certain that the entry gate is closed.

It is prohibited to keep the entry gate in an open position when the platform is raised.

To extend the height or the range by placing of ladders, scaffolds or similar devices on the platform is prohibited.

Never perform service on machine while the platform is elevated without blocking the scissors structure.

Inspect the machine thoroughly for cracked welds, loose or missing hardware, hydraulic leaks, loose wire connections, and damaged cables or hoses before using.

Verify that all placards and decals are in place and legible before using the machine.

Never use a machine that is damaged, not functioning properly, or has damaged or missing placards and decals.

To bypass any safety equipment is prohibited and presents a danger for the persons on the aerial work platform and in its working range.

Never charge batteries near sparks or open flame. Charging batteries emit explosive hydrogen gas.

Modifications to the aerial work platform are prohibited or permissible only at the approval by Snorkel.

After use, secure the work platform from unauthorized use by turning the keyswitch off and removing key.

Driving MEWP's on public highways is subject to national traffic regulations.

Certain inherent risks remain in the operation of this machine despite utilizing proper design practices and safeguarding.

Fall protection anchors are provided in the platform and the manufacturer recommends the usage of a fall restraint or fall arrest device as required by national or local regulations and standards.

Care must be taken to ensure that the machines meets the requirements of stability during use, transportation, assembly, dismantling when out of service, testing, or foreseeable breakdowns.

In the event of an accident or breakdown see Chapter 11 – Emergency Operation. Do not operate the aerial platform if it is damaged or not functioning properly. Qualified maintenance personnel must correct the problem before putting the aerial platform back into service.

Chapter 4 – Safety Devices

This aerial work platform is manufactured with safety devices, placards, and decals to reduce the likelihood of an accident.

- For the safety of all personnel, do not disable, modify, or ignore any safety device.
- Safety devices are included in the daily prestart inspection.

Warning

The potential for an accident increases when safety devices do not function properly. Death or serious injury could result from such accidents. Do not alter, disable, or override any safety device.

If any safety devices are defective, remove the aerial platform from service until qualified maintenance personnel can make repairs.

Emergency Stop Controls

There is an emergency stop control at the lower and upper controls.

At the lower controls, the emergency stop is a two-position red push button (refer to Figure 4.1).

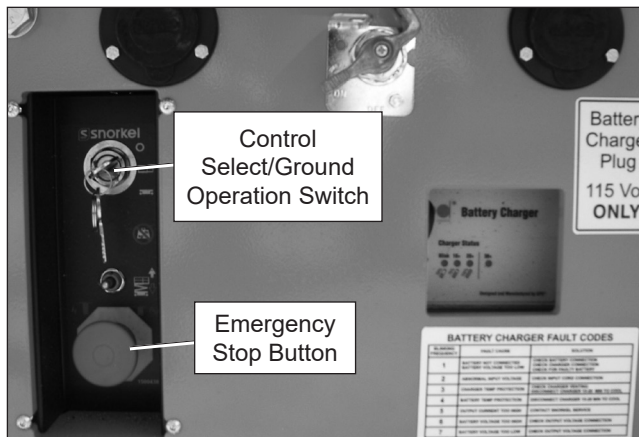

Figure 4.1 – Lower Controls

- Push the emergency stop button inward to disconnect power to all control circuits.
- Pull the button outward to restore power. Some early buttons require twisting to restore power.

Note

On ANSI machines, the lower controls override the upper controls. If the upper control emergency stop button is engaged, the lower controls can still be used to operate the aerial platform. On CE/AS/NZS machines, if one emergency stop is engaged the machine will not operate.

At the upper controls, the emergency stop is a two-position red push button (refer to Figure 4.2).

Push the emergency stop button inward when the upper controls are not in use to protect against unintentional operation.

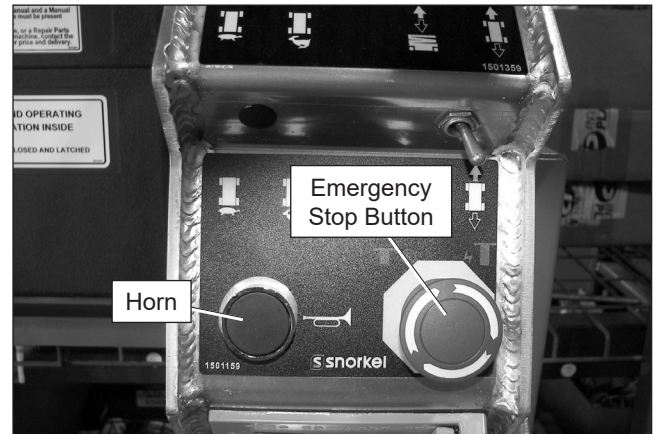

Figure 4.2 – Upper Control Panel Front

- Push the emergency stop button inward to disconnect power to the upper control circuits.
- Pull the button outward to restore power. Some early buttons require twist to restore power.

Control Select/Ground Operation Switch

The control select/ground operation switch (refer to Figure 4.1) prevents platform movement if the platform raise/lower switch on the lower control panel is accidentally moved.

Hold the switch downward continually in the lower control position to enable the platform raise/lower switch functions.

Upper Control Interlock Switch

The interlock switch (refer to Figure 4.3) prevents platform movement if the joystick on the upper control panel is accidentally moved.

Engage the interlock by grasping the joystick and pulling the switch toward the handle to activate the steering, drive, lift and lower functions.

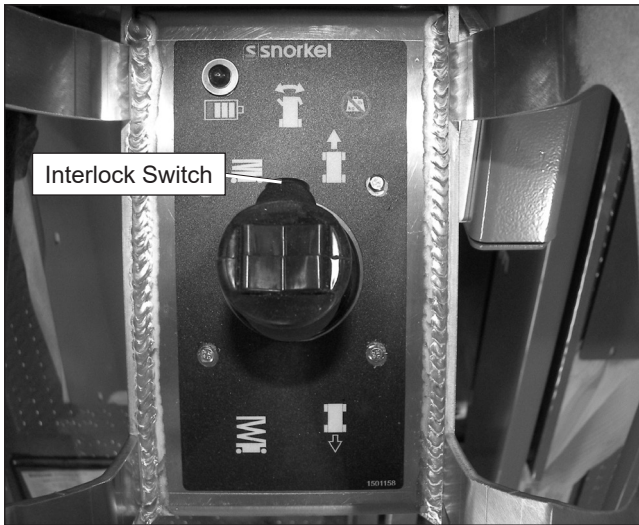

Figure 4.3 – Upper Control Panel Top

Drive Motion Alarm

When the joystick is moved out of neutral to drive the aerial platform, the alarm emits a loud beeping sound to warn personnel in the work area to stand clear.

Pothole Protector Skids

The pothole protector skids automatically lower when the platform is elevated approximately 24" (61 cm). Ground clearance is reduced from 2.63" (6 cm) to 3/4" (1.9 cm) when the skids lock into position (refer to Figure 4.4).

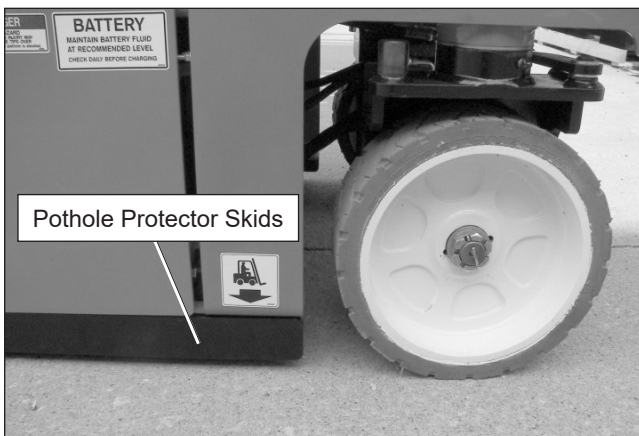

Figure 4.4 – Pothole Protector Skids

Danger

The aerial platform can tip over if it becomes unstable. Death or serious injury will result from a tip-over accident. Do not drive or position the aerial platform for elevated use within 4' (1.2 m) of any drop-off, hole, or other tip-over hazard.

This protection system limits the tilt angle if a wheel is driven into a drop-off or hole. This greatly reduces the likelihood of the aerial platform tipping over.

The pothole protection system is for added protection and does not justify operating near drop-offs or holes.

Drive/Lift Pothole Protector Interlock

The aerial platform drive and lift functions are interlocked through a limit switch that senses whether or not the pothole protection linkage is locked into position. The drive/lift pothole interlock operates when the platform is elevated approximately 6' (1.8 m).

If an obstruction under the skids, or some other impairment prevents the skids from locking into position, the drive and steer functions will not operate.

Lower the platform and remove the obstruction when the drive/lift pothole protector interlock is engaged.

Drive/Lift Level Sensor Interlock

The aerial platform drive and lift functions are interlocked through a level sensor system. The drive/lift level sensor interlock operates when the platform is elevated approximately 6' (1.8 m).

The drive and lift functions will not operate and an alarm will sound if the chassis is tilted more than the factory preset level sensor value. The setting for the degree of slope, side-to-side and front-to-rear, varies depending on the requirements of the applicable governing body (ANSI, CSA, CE, AS, NZS) that the machine was manufactured to conform to.

Refer to the machines General Specifications for the drive/lift level sensor interlock level sensor values.

Lower the platform and drive to a level surface when the drive/lift level sensor alarm sounds.

The drive/lift level sensor system is for added protection and does not justify operating on anything other than firm, flat, level surfaces.

Progressive Tilt

The progressive tilt system allows the machine to be operated on greater side-to-side slopes when the platform is below maximum rated height. As the platform is elevated, the degree of side-to-side slope the machine may be operated on decreases. Refer to Appendix D – Progressive Tilt to determine the relationship between platform height and degree of slope for specific machine models.

S3226E machines with the following serial numbers are equipped with a progressive tilt system:

- S3226E-04-190501073 and after
- S3226E-01-190100398 and after

All other scissor machines manufactured June 2020 and after are equipped with progressive tilt.

Lowering Alarm

When the joystick is moved out of neutral to lower the platform, the alarm emits a loud beeping sound to warn personnel in the work area to stand clear.

⚠ Danger

Pinch points exist on the scissors structure. Death or serious injury will result if the scissors structure lowers onto personnel within the scissors arms or under the raised platform. Stand clear while raising and lowering the platform.

Be careful when lowering the platform. Keep hands and fingers away from the scissors structures components.

Emergency Lowering Lever/Handle

The emergency lowering lever/handle may be used to lower the platform if there is a malfunction in the hydraulic or electrical system.

The lever for the S3215L/S3215E/S3219E is mounted at the front of the aerial platform (refer to Figure 4.5).

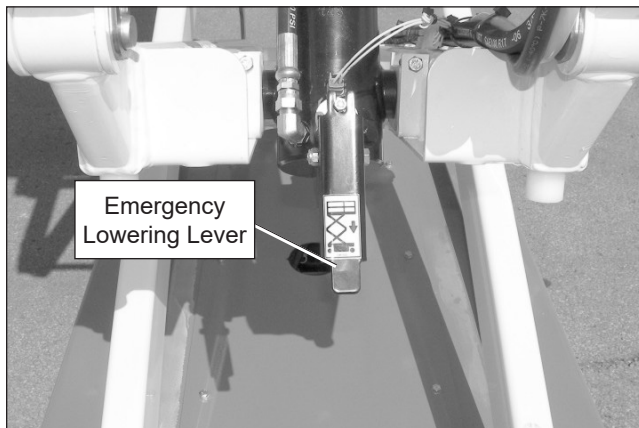

Figure 4.5 – Front of Machine

The handle for the S3220E/S3226E/S4726E/S4732E is mounted at the rear of the aerial platform (refer to Figure 4.6).



Figure 4.6 – Rear of Machine

⚠ Danger

Pinch points exist on the scissors structure. Death or serious injury will result if the scissors structure lowers onto personnel within the scissors arms or under the raised platform. Stand clear while operating the emergency lowering lever/handle to lower the platform.

- Keep hands and fingers away from the scissors structure components.
- S3215L/S3215E/S3219E – push downward on the emergency lowering lever at the front of the machine to lower the platform.
- S3220E/S3226E/S4726E/S4732E – pull outward on the emergency lowering handle at the rear of the machine to lower the platform.

Safety Prop

The safety prop (refer to Figure 4.7) is used to support the scissors structure when access to the scissors arm components or the chassis is required. Always use the safety prop when the platform is raised during inspection and maintenance.



Figure 4.7 – Safety Prop

Guardrails

The guardrails (refer to Figure 4.8) help protect personnel from falling off the platform.

The guardrail system includes:

- A top rail
- A mid rail
- Saloon style entry doors
- Toeboards around the sides of the platform.

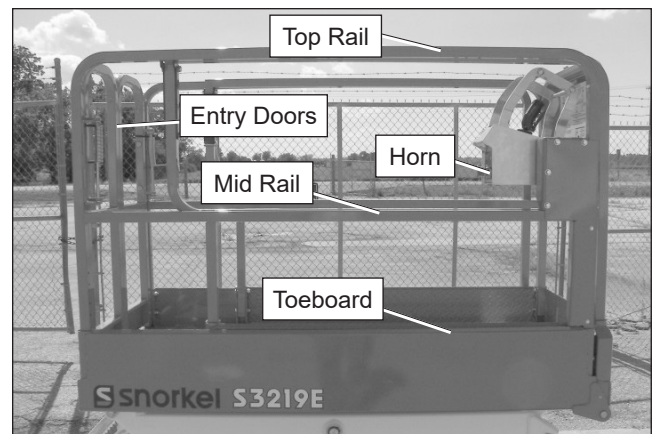

Figure 4.8 – Platform

The entry doors allow for access to the platform. The doors must be securely closed except when personnel are entering or leaving the platform.

Ground Fault Circuit Interrupter

The electrical power outlet (refer to Figure 4.9), at the platform contains a ground fault circuit interrupter (GFCI) to provide protection for personnel.



Figure 4.9 – Upper Controls

Tilt Alarm

An alarm will sound if the aerial platform chassis is out of level when the platform is raised. Refer to the machine general specifications for the specific level sensor settings.

▲ Danger

The aerial platform can tip over if it becomes unstable. Death or serious injury will result from a tip-over accident. Do not drive or position the aerial platform for elevated use near any drop-off, hole, slope, soft or uneven ground, or other tip-over hazard.

Completely lower the platform and drive to a level surface when the tilt alarm sounds.

The tilt alarm is for added protection and does not justify operating on anything other than firm, flat, level surfaces.

Overload Protection

When the load in the platform is near or at rated capacity, an alarm will sound and the red light on the lower controls will flash.

The alarm and light warn the operator that the platform is close to becoming overloaded. All functions remain fully operational.

▲ Danger

The aerial platform can tip over if it becomes unstable. Death or serious injury will result from a tip-over accident. Do not exceed the capacity values indicated on the platform rating placard.

If the platform is overloaded, when it is elevated just past 6' (1.8 m), a control module will stop the lift and drive functions and the alarm will slowly beep and the warning light will be on. The platform can still be lowered to remove the excess load using the upper controls or the emergency lowering system only.

If the platform is elevated just past 6' (1.8 m) and material is added to the platform overloading it, a control module will stop the lift, drive and lower functions. The alarm will slowly beep and the warning light will be on. In this case, remove the load in excess of rated capacity to return to normal operation.

If the emergency lowering lever/handle is activated when the platform is overloaded, the lower controls will not operate and the LCD will display "Function Locked Emergency Lowering Detected." In this case, remove the load in excess of rated capacity and enter the pass code on the LCD keypad to return to normal operation.

Lowering Interrupt – CE/AS/NZS

When the platform is lowered to about 6' (1.8 m) lowering stops, the flashing light is constant on and the alarm sounds in fast short beeps. The platform will not lower for five seconds regardless of the control position to allow personnel to clear the area of the scissors before the platform completely lowers.

Center the control in neutral to reset the lowering function, then continue to lower the platform.

When the platform is below 6' (1.8 m) and the control is moved to lower the platform, there is a 1.5 second delay before movement begins.

Horn

The horn may be used to warn personnel on the ground. The horn is operational when the machine is set up for operation from the upper controls.

The horn button is located on the front of the upper control panel (refer to Figure 4.2).

Flashing Light

An optional amber flashing light may be located under the upper control box. The flashing light warns personnel that the aerial platform is in the area.

The light flashes at about one flash per second when the machine is set up for operation from the upper controls.

When the platform is lowered and the lowering interrupt is active, the light is constantly on.

Snorkel Guard

The optional Snorkel Guard (refer to Figure 4.10) is a mechanically activated guarding system which offers an additional level of protection to the operator at the upper controls.

If an operator is involuntarily pushed against the spring-loaded Snorkel Guard rail that is mounted above the upper control panel, the machine functions are disabled.

When the Snorkel Guard is activated:

- the horn sounds.
- the blue light under the upper control panel flashes.
- only the platform lower function will operate.

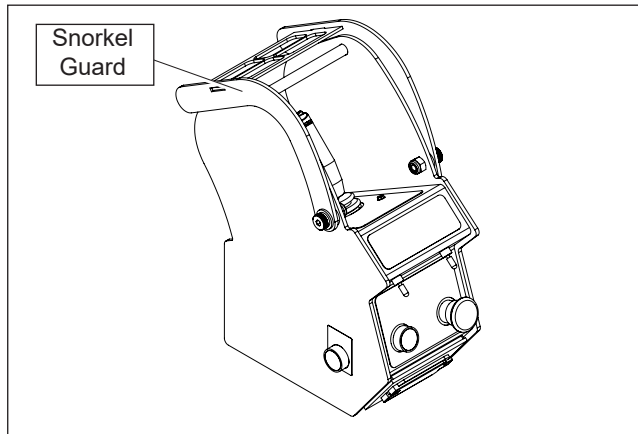

Figure 4.10 – Upper Controls

The lower controls are not affected by the Snorkel Guard activation.

Perimeter Lights

The optional perimeter lights provide a visual warning for pedestrians by projecting a blue warning dot on the ground at the front and rear of the machine, and a red boundary line on each side.

The perimeter lights are operational when the interlock switch on the upper controls or the interlock button on the loading controls is engaged.

Chapter 5 – Gauges and Displays

The aerial platform is equipped with several gauges to monitor the condition of the machine before and during operation.

Battery Charge Indicator – ProCharger

The battery charger has three LED's (refer to Figure 5.1) which indicate the charger status.

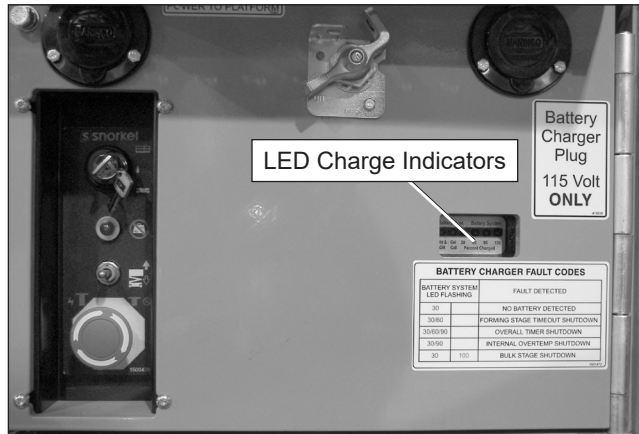

Figure 5.1 –Rear of Chassis

The LED's are visible on the battery tray.

- 30% red LED blinking – indicates that the batteries are 0% to 30% charged.
- 60% red LED blinking – indicates that the batteries are 30% to 60% charged.
- 90% red LED blinking – indicates that the batteries are 60% to 90% charged.
- 100% green LED solid On – indicates that the charge cycle is complete.

Battery Charge Indicator – Pylon

The battery charger has three LED's (refer to Figure 5.2) which indicate the charger status.

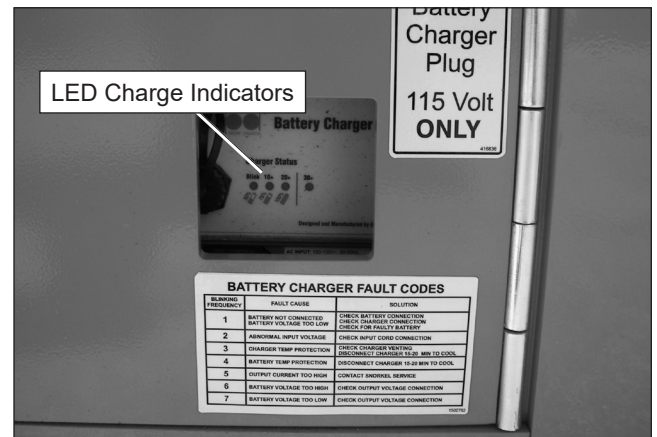

Figure 5.2 – Rear of Chassis

The LED's are visible on the battery tray.

- 50% LED blinking – indicates less than 50% capacity.
- 50% LED solid On – indicates more than 50% capacity.
- 75% LED solid On – indicates more than 75% capacity.
- 100% LED solid On – indicates 100% capacity.

Battery Condition Indicator

The battery condition indicator (refer to Figure 5.3) is located on the top of the upper control panel. When the light comes on, the lift voltage is cut out and drive speed is reduced to slow.

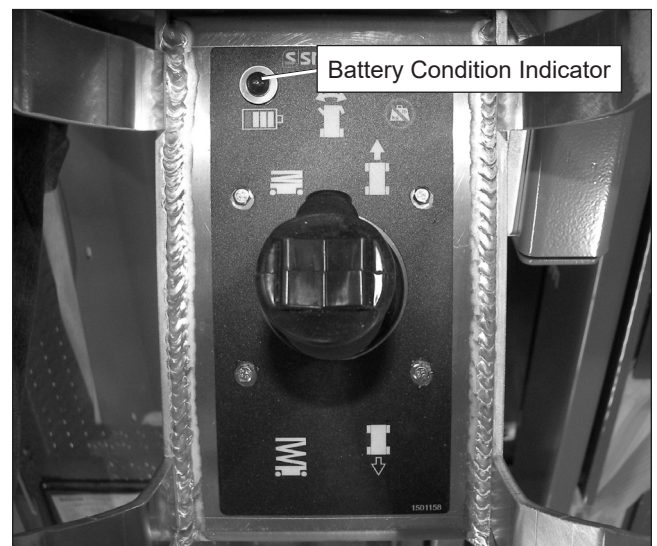

Figure 5.3 – Top of Upper Controls

Diagnostic Center Display

The diagnostic center LCD display (refer to Figure 5.4) is located in the control valve tray on the right side of the machine.

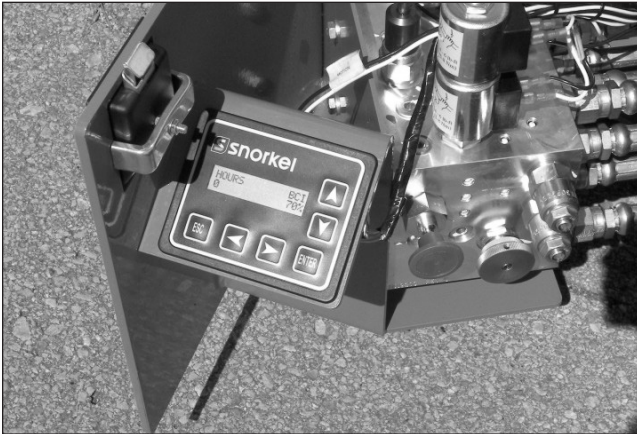

Figure 5.4 – Diagnostic Center LCD Display

When the battery disconnect and emergency stop button at the lower controls are in the on position, the LCD display shows:

- The accumulated aerial platform operating time
- The available battery power to operate the machine.

Chapter 6 – Batteries

Each battery tray contains two, 6 volt batteries. These batteries supply 24 volt DC electrical power to operate the aerial platform drive and platform control systems. Proper machine operation depends on well maintained and charged batteries.

General Maintenance

Always keep the batteries clean, free of dirt and corrosion. A film on top of the battery can accelerate discharge.

⚠Warning

Battery acid can damage the skin and eyes. Serious infection or reaction could result if medical treatment is not given immediately. Wear face and eye protection when working near the batteries.

Use distilled water to refill the batteries. Avoid water containing metallic solids such as iron which can reduce the life of the batteries.

Consult a battery charger specialist if extreme temperature use is unavoidable.

- Cold reduces battery capacity and retards charging.
- Heat increases water usage and can result in overcharging.
- Very high temperatures can cause thermal run away which may lead to an explosion or fire.

Charging

The aerial platform is equipped with an automatic battery charger that will completely recharge the batteries and turn off after the charge cycle is completed.

⚠Warning

Batteries give off hydrogen and oxygen that can combine explosively. Death or serious injury could result from a chemical explosion. Charge the batteries only in a well ventilated area away from sparks or flame.

⚠Caution

The batteries may be overcharged and/or damaged if the charger fails to shut off automatically. Do not leave the battery charger on for more than two days.

It may take from 1 1/2 to 16 hours to recharge the batteries depending on the amount of discharge. If the charging cycle exceeds 16 hours without the batteries being fully recharged, shut off the charger and have the batteries checked.

Fully recharge the batteries, immediately after use.

- One charging cycle per day is preferred.
- Fully charged batteries perform best.

- The deeper the discharge, the fewer number of cycles a battery will deliver. Deep discharges deteriorate the battery quicker than light shallow cycles.
- An overly discharged battery may need to be cycled a few times before it can fully recover.
- If a battery begins to heat before becoming fully charged, it may be necessary to recharge and discharge the battery a few times.

Use the following procedure to charge the batteries.

1. The battery disconnect switch is at the rear of the chassis, below the entry step (refer to Figure 6.1). Turn the battery disconnect switch off.

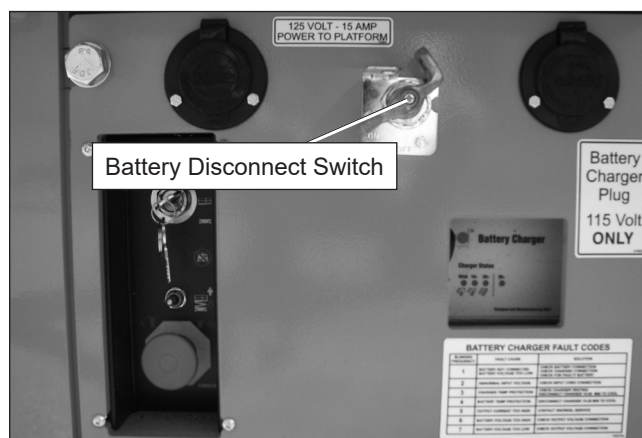

Figure 6.1 – Rear of Chassis

2. Check the battery water level. Add water to individual cells only if the plates are exposed. Replace the battery caps.
3. Plug the charger into a properly grounded AC outlet using a 3 conductor, 12 gauge or larger extension cord. The extension cord must be as short as possible and in good electrical condition.
4. Leave the charger plugged in until it shuts itself off.
5. Unplug the extension cord after the charger turns itself off. Allow the batteries to cool off after charging.
6. Check the battery water level. Add water to individual cells only if the plates are exposed. Replace the battery caps.

Chapter 7 – Controls

⚠ Danger

Pinch points may exist between moving components. Death or serious injury will result from becoming trapped between components, buildings, structures, or other obstacles. Make sure all personnel stand clear while operating the aerial platform.

- Controls to position the platform are located on the lower control panel on the chassis and on the upper control panel in the platform.
- Controls to drive the aerial platform are located on the upper control panel only.

Battery Disconnect

The battery disconnect switch is at the rear of the platform, below the entry step (refer to Figure 7.1).

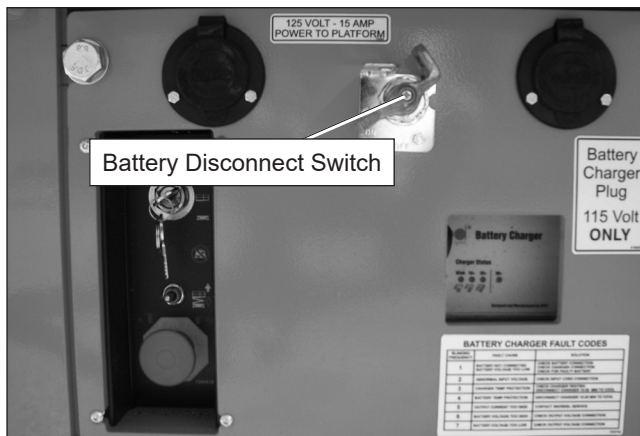

Figure 7.1 – Rear of Chassis

The battery disconnect switch removes electrical power from all electrically controlled functions when in the off position.

- Place the switch in the on position to operate any electrically controlled function.

⚠ Caution

Only authorized personnel should operate the aerial platform. Unqualified personnel may cause injury to coworkers or property damage. Lock the battery disconnect switch in the off position before leaving the aerial platform unattended.

- Lock the battery disconnect switch in the off position to prevent unauthorized use of the aerial platform.

Lower Controls

The lower controls (refer to Figure 7.2) are located at the rear of the chassis. Only platform functions can be operated from the lower controls.

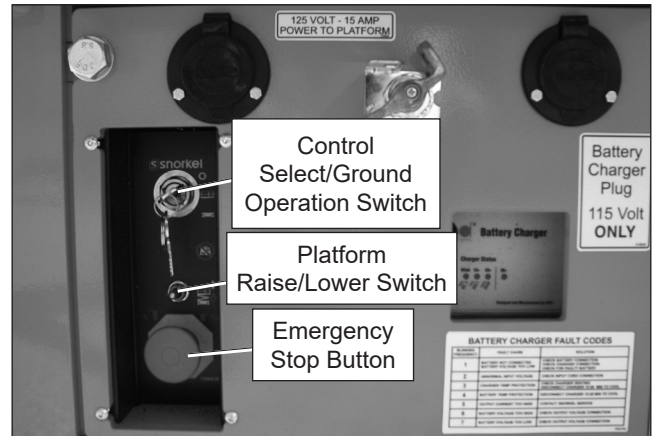

Figure 7.2 – Lower Controls

The following are located on the lower control panel:

- Emergency stop button
- Control selector/ground operation switch
- Platform raise/lower switch
- Platform overload protection light

Emergency Stop Button

The emergency stop is a two-position red push button.

- Push the button inward to disconnect power to all control circuits.
- Pull the button outward to restore power. Some early buttons require twisting to restore power.

Control Selector/Ground Operation Switch

Insert the key into the control selector/ground operation switch.

- In the upper position, aerial platform functions will not operate from the lower or upper controls.
- Turn the switch to the upper controls position to operate the aerial platform functions from the upper controls.
- Hold the switch downward continually in the lower controls position to enable the platform raise/lower switch functions. The switch is spring returned to the upper controls position.

The upper controls will not operate while the control selector is in the lower position.

Platform Raise/Lower Switch

The platform raise/lower switch is used to raise or lower the platform. The switch is spring returned to the center off position.

- Hold the switch upward to raise the platform.
- Hold the switch downward to lower the platform.
- An alarm will sound as the platform lowers.

Upper Controls

The upper controls (refer to Figure 7.3) are located on the control panel in the platform. The upper control pendant is located at the right front of the platform. Platform and drive functions can be operated from the upper controls.

Warning

The potential for an accident increases from improperly driving or steering the aerial platform. Death or serious injury could result from such accidents. Make sure the upper control panel is securely fastened inside the platform and facing the front of the machine.

Avoid driving the platform with the upper controls facing the rear or side of the machine. In this position the machine is difficult to control because the drive and steer control movements and their resulting machine movements will not correspond.

Only operate the upper controls when the upper control panel is securely fastened inside the platform and facing the front of the machine. Some machines may have an optional removable upper control panel. Remove the pin to remove the panel from the guardrails.

The following are located on the upper control panel:

- Emergency stop button
- Drive/lift selector switch
- Drive range switch
- Joystick to control platform lift, drive, and steer
- Horn button
- Battery condition indicator
- Platform overload protection light

Emergency Stop Button

The emergency stop (refer to Figure 7.3) is a two-position, red push button on the front of the upper control panel.

- Push the button inward to disconnect power from all control circuits at the upper controls.
- Pull the button outward to restore power. Some early buttons require twisting to restore power.
- **Push the emergency stop button inward when the upper controls are not in use to protect against unintentional operation.**

Note

On ANSI machines, the lower controls override the upper controls. If the upper control emergency stop button is engaged, the lower controls can still be used to operate the aerial platform. On CE/AS/NZS machines, if one emergency stop is engaged the machine will not operate.

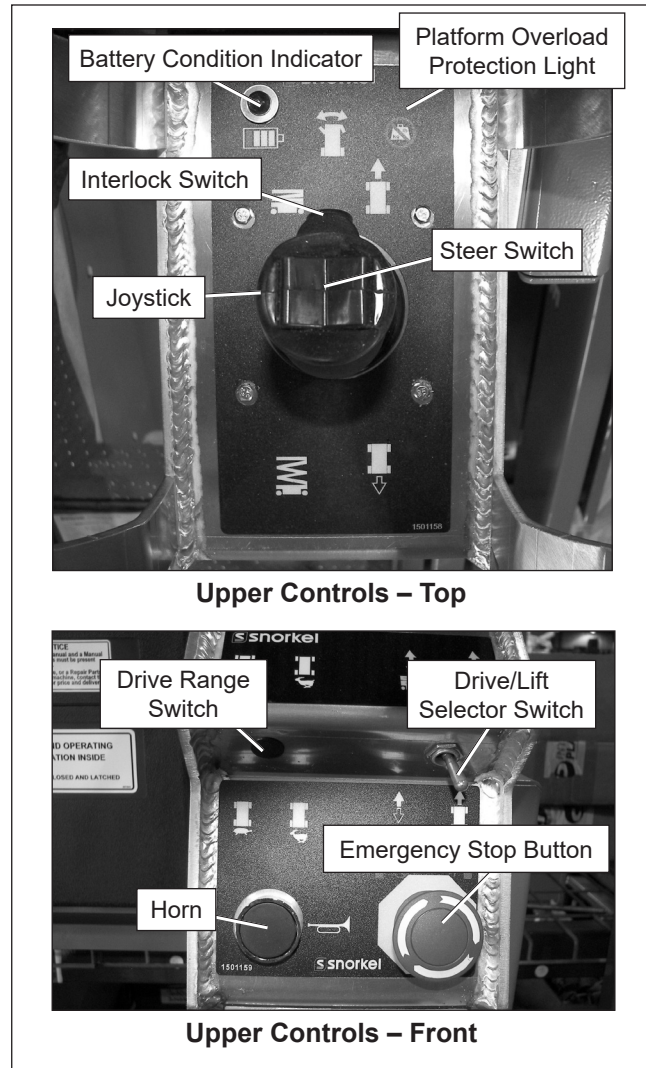

Figure 7.3 – Upper Controls

Drive/Lift Selector Switch

The drive/lift selector switch (refer to Figure 7.3) is used to select either machine drive or lift functions. Both functions can not be operated at the same time.

- Place the drive/lift selector switch in the drive position to drive the aerial platform using the joystick. The platform will not raise or lower while driving.
- Place the drive/lift selector switch in the lift position to raise and lower the platform using the joystick.

Joystick

Use the joystick (refer to Figure 7.3) to operate the following functions:

- Aerial platform steering
- Aerial platform drive and speed
- Platform raise/lower and speed

Movement of the joystick in a given direction produces a corresponding movement of the aerial platform. The steering and drive functions may be operated separately or simultaneously.

Interlock Switch

The joystick has an interlock switch in the handle (refer to Figure 7.3).

- Engage the interlock by grasping the joystick and pulling the switch toward the handle.
- Engage the interlock to activate the steering, drive, or lift functions.

Steer Switch

The steer switch (refer to Figure 7.3) is a momentary contact, rocker switch on top of the drive joystick. This switch controls the two front wheels to steer the aerial platform.

- To steer to the right, engage the interlock switch on the joystick and hold down the right side of the steer switch.
- To steer to the left, engage the interlock switch on the joystick and hold down the left side of the steer switch.

Note

The steering wheels are not self-centering. Set the steering wheels straight ahead after completing a turn.

Drive Range Switch

The drive range switch (refer to Figure 7.3) has two positions to select drive wheel operation:

- High (Rabbit) – for normal driving conditions
- Low (Turtle) – for driving on grades up to 25 percent that require low speed and high torque operation, where high range is not sufficient to climb the grade.

Note

Some early model S3219E and S3220E machines were not equipped with a drive range switch.

Horn Button

The horn button (refer to Figure 7.3) is on the front of the upper control panel.

Press the button to sound the horn.

Battery Condition Indicator

The battery condition indicator (refer to Figure 7.3) is located on the top of the upper control panel. When the light comes on, the lift function is cut out and drive speed is reduced to slow.

Loading Controls

The loading controls are located beneath the upper control box on the platform guardrail. Drive functions may be operated from this location when loading the machine. The loading controls may be a fixed side drive or a corded pendant (refer to Figure 7.4). Pull the upper control emergency stop button outward to activate the loading controls.

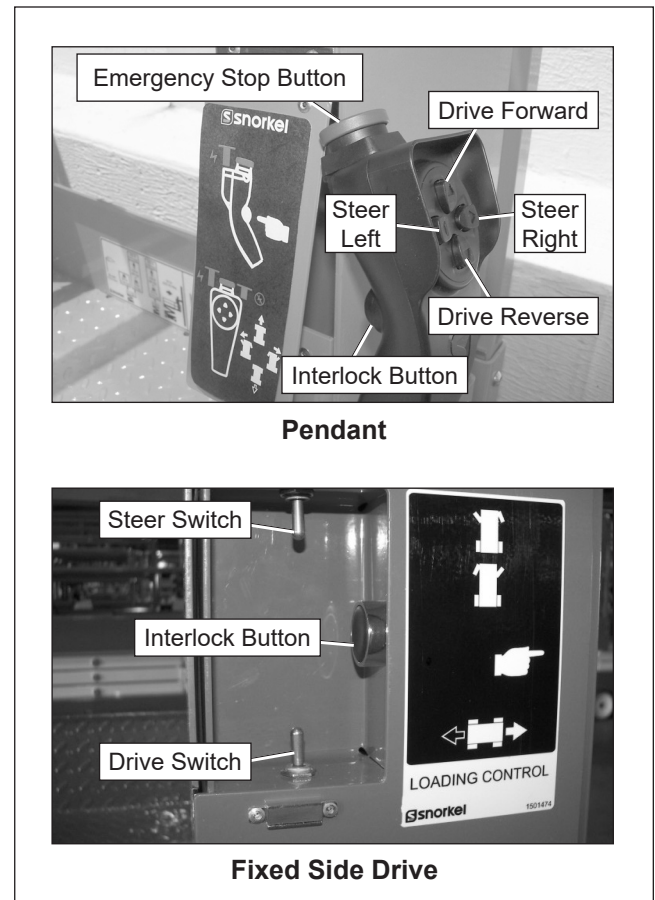

Figure 7.4 – Loading Controls

The following are located on the loading controls:

- Emergency stop button – pendant only
- Interlock button
- Drive forward/reverse control
- Steer left/right control

Emergency Stop Button

The emergency stop (refer to Figure 7.4) is a two-position, red push button on the top of the pendant.

- Push the button inward to disconnect power from the pendant.
- Pull the button outward to restore power.
- **Push the emergency stop button inward when the pendant is not in use to protect against unintentional operation.**

Interlock Button

The controls have an interlock button to activate drive functions (refer to Figure 7.4). For pendant controls, engage and hold the interlock button while activating the loading controls.

For fixed side drive controls, press and release the interlock button to activate the loading controls. If no control is operated within five seconds of pressing the interlock button, it will have to be pressed again.

Drive Switch

The drive switches (refer to Figure 7.4) are momentary contact. These switches control the two front wheels to drive the aerial platform.

- On the pendant – engage the interlock button and hold down either the drive forward or drive reverse button.
- On the fixed side drive – to drive forward, press the interlock button inward and hold the switch forward. To drive in reverse, press the interlock button inward and hold the switch rearward.

Steer Switch

The steer switches (refer to Figure 7.4) are momentary contact. These switches control the two front wheels to steer the aerial platform.

- On the pendant – press the interlock button and hold down either the steer left or steer right button.
- On the fixed side drive – press the interlock button and hold the switch in the appropriate direction to steer either left or right.

Note

The steering wheels are not self-centering. Set the steering wheels straight ahead after completing a turn.

Override Switch

When the Snorkel Guard or the platform overload system is activated, the override button (refer to Figure 7.5) is used to override the system to operate platform raise/lower and drive functions.

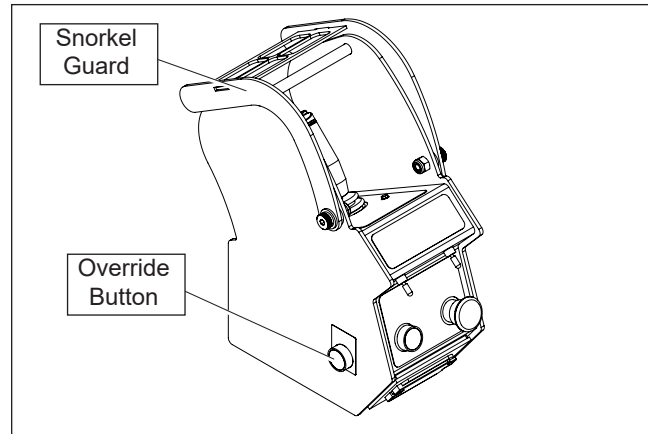

Figure 7.5 – Upper Controls

The button is spring returned to the normal operation position.

- Hold the button inward to override the Snorkel Guard or the platform overload system.
- Release the button to resume normal machine operation.

Chapter 8 – Prestart Inspection

Potential service and safety problems may be detected by inspecting the aerial platform. This chapter includes information on properly inspecting the aerial platform and includes a prestart inspection check list at the end of this chapter to ensure that no areas are overlooked.

Warning

The potential for an accident increases when operating an aerial platform that is damaged or malfunctioning. Death or serious injury could result from such accidents. Do not operate the aerial platform if it is damaged or malfunctioning.

Perform a prestart inspection at the beginning of each shift, before using the aerial platform on the job. The inspection site must have a smooth and level surface.

Note

Carefully read, understand and follow all safety rules, operating instructions, labels and National Safety Instructions/Requirements.

Operator's Manual

The manual holder is located on the floor of the platform (refer to Figure 8.1).



Figure 8.1 – Operator's Manual Holder

To inspect the operator's manual and manual holder:

1. Make certain the Operator's Manual holder is securely fastened in place.
2. Check to see that the proper Operator's Manual is in the holder.
3. Check to see that the manual is complete with all pages intact and in readable condition.
4. Make certain ANSI publication "Manual of Responsibilities for Dealers, Owners, Users, Operators, Lessors and Lessees of ANSI/SIA A92.6-2006 Self-Propelled Elevating Work Platforms" is in the manual holder.

Electrical System

Electrical power is supplied from four, 6 volt batteries. The batteries supply 24 volt DC electrical power to operate the aerial platform drive and control system. There is a battery tray on each side of the machine. Each tray contains two batteries.

Warning

Batteries give off hydrogen and oxygen that can combine explosively. Death or serious injury could result from a chemical explosion. Do not smoke or permit open flames or sparks when checking the batteries.

Caution

Even with low voltage electrical systems, severe arcing can occur. Electrical shock or component damage may result from contact with energized conductors. Use caution when working with any electrical device.

For optimal battery performance the battery fluid level must be maintained and the battery connections must be kept clean.

Battery Fluid Level

To inspect the battery fluid level:

1. Remove the caps from the batteries (refer to Figure 8.2).

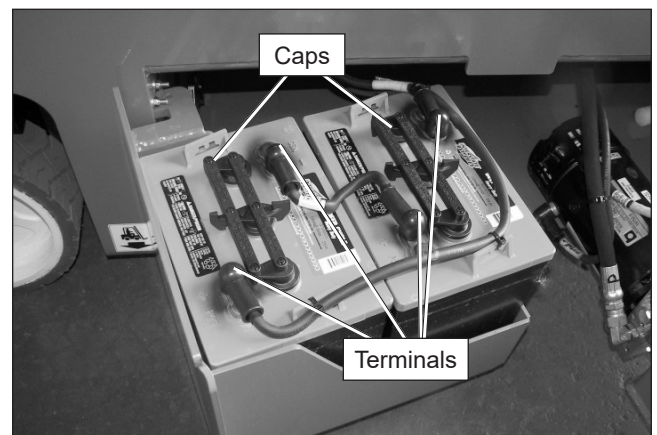

Figure 8.2 – Battery Tray

2. Visually check the battery fluid level making sure the level is $\frac{1}{4}$ " (6 mm) above the plates.
3. If necessary, add distilled water.

Note

Use only distilled water when refilling the battery. Tap water may contain metallic solids such as iron which can reduce the life of the battery.

4. Replace the caps on the battery. The caps must be in place and tight during machine operation and battery charging.

Battery Terminals

To inspect the battery terminals:

1. Check the top of the battery, the terminals, and cable ends (refer to Figure 8.2). They should be clean and free of corrosion.
2. If necessary, clean the top of the battery. Clean the terminals and cable ends with a wire brush or terminal cleaning tool.
3. Make sure all cable ends are securely fastened to the terminals.

Battery Charger

Inspect the battery charger (refer to Figure 8.3) to ensure that it is operating properly.

1. Turn the battery disconnect switch off.
2. Plug the charger into a source of power.
3. Observe the LED's on the charger to determine the charger status. If necessary, refer to the charger decal or to Battery Charge Indicator in Chapter 5 to determine when the batteries are fully charged.

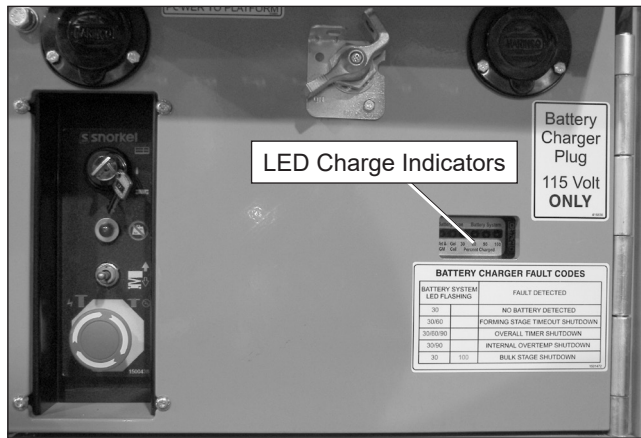

Figure 8.3 – Rear of Chassis

4. Unplug the charger.

Safety Prop

Always use the safety prop when the platform is raised before inspecting or performing service or maintenance procedures on the machine.

⚠ Danger

Pinch points exist on the scissors structure. Death or serious injury will result if the scissors structure drops onto personnel working within the scissors

arms or under the raised platform. Properly position the safety prop before reaching through the scissors structure.

Use the following procedure to properly position the safety prop:

1. Remove all tools and material from the platform.
2. Using the lower controls, raise the platform until the open height between the arm pins is wide enough to position the safety prop.
3. Rotate the safety prop downward from the storage position to the support position (refer to Figure 8.4).



Figure 8.4 – Safety Prop in Support Position

4. Remove hands and arms from the scissors structure area.
5. Lower the platform until the scissors are supported by the safety prop.

Use the following procedure to stow the safety prop:

1. Using the lower controls, raise the platform until the open height between the arm pins is wide enough to move the safety prop.
2. Rotate the safety prop upward to the stowed position (refer to Figure 8.5).

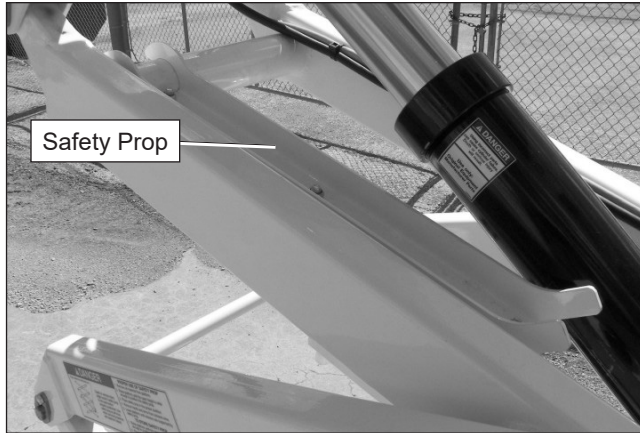

Figure 8.5 – Safety Prop in Stowed Position

- Using the lower controls completely lower the platform.

Cables and Wiring Harness

To inspect the cables and wiring harness:

- Visually inspect all cables and wiring for wear and/or physical damage such as loose connections, broken wires, and frayed insulation.
- Check the wiring in areas where a change in routing direction may cause them to become pinched.
- Make sure the cables and wires are properly routed to avoid sharp edges, pinching, and scuffing.

Hydraulic System

Hydraulic power is supplied from a single stage hydraulic pump with a 4.25 horsepower DC electric motor.

⚠️ Danger

Hydraulic fluid escaping under pressure can have enough force to inject fluid into the flesh. Serious infection or reaction will result if medical treatment is not given immediately. In case of injury by escaping hydraulic fluid, seek medical attention at once.

The hydraulic reservoir, pump, and filter are located in the hydraulic tray on the left side of the chassis. Unlatch and swing out the tray to inspect the hydraulic components.

Fluid Level

To inspect the fluid level:

- Make sure the aerial platform is fully stowed on a level surface. Swing out the hydraulic tray and visually check to make sure the fluid is visible in the sight gauge (refer to Figure 8.6). Some machines may have a fill cap with a dipstick. The fluid must be visible on the dipstick.

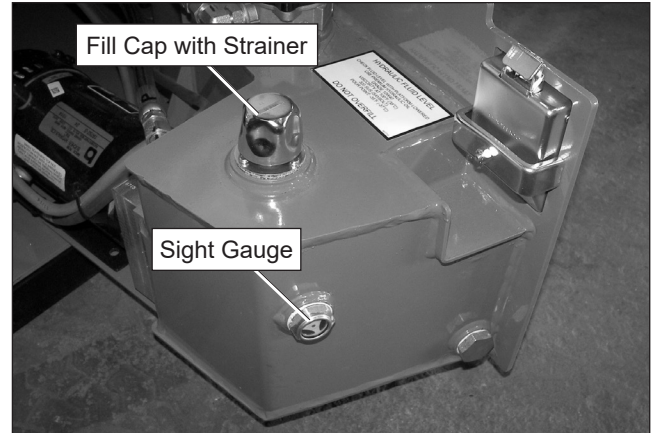

Figure 8.6 – Hydraulic Tray

⚠️ Caution

Not all hydraulic fluid is suitable to use in the hydraulic system. Some have poor lubricating characteristics and may increase component wear. Only use hydraulic fluid as recommended.

- If necessary, add fluid of the proper type.

Note

Refer to Chapter 2 for the proper type and grade of hydraulic fluid to use. The need to regularly add fluid indicates a leak that should be corrected.

- Replace the cap making sure it is secured in place.

Hoses, Tubes, and Fittings

To inspect the hoses, tubes and fittings:

- Inspect all hydraulic hoses, tubes, and fittings for wear, leakage, or damage (refer to Figure 8.7).

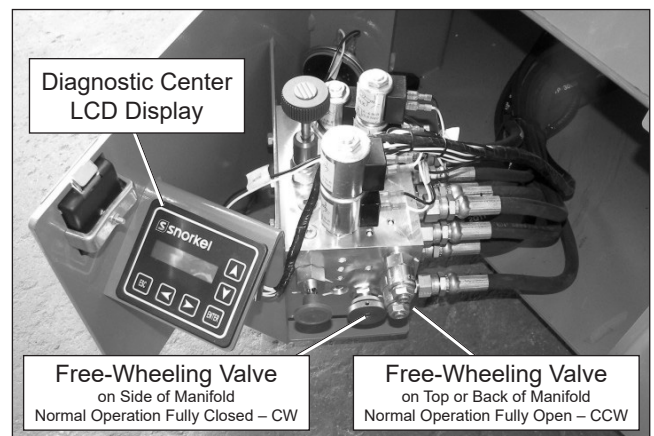

Figure 8.7 – Control Valve Tray
Right Side of Chassis

- Make sure the hoses are properly routed to avoid sharp edges, kinking, and scuffing.
- Inspect the tubes for dents or other damage that may restrict fluid flow.

4. Make sure all hoses and tubes are held firmly in their support brackets.
5. Check under the chassis for fluid that has leaked. Hydraulic fluid leaks are easily visible on the ground.

Free-Wheeling Valve

The free-wheeling valve is on the hydraulic manifold in the control valve tray. On some manifolds the valve is on the side and on others it is on the back (refer to Figure 8.7).

Check the free-wheeling valve to make sure it is in its normal operation position.

Diagnostic Center Display

To test the diagnostic center display in the control valve tray (refer to Figure 8.7), from the lower controls:

1. Turn the battery disconnect switch to the on position.
2. Pull the emergency stop button outward to the on position.
3. The display on the LCD screen should indicate:
 - The accumulated aerial platform operating time.
 - The available battery power to operate the machine.

Tires and Wheels

Visually inspect the tires and wheels (refer to Figure 8.8) to make sure they are suitable for service.

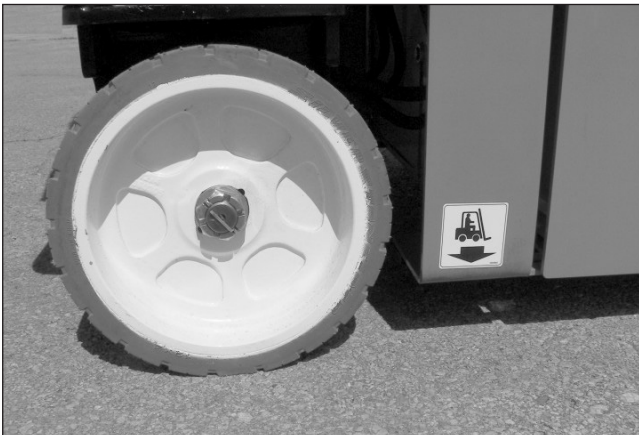

Figure 8.8 – Tires and Wheels

To inspect the tires and wheels:

1. Visually inspect the tires. They should be smooth without any cuts, gouges, or missing rubber that might affect aerial platform stability.
2. Check the wheels to see that the fasteners are in place and are not damaged or loose.

Ground Strap

Make certain the ground strap (refer to Figure 8.9) is securely fastened to the chassis. It should be long enough to contact the ground surface to eliminate static electricity from the machine.

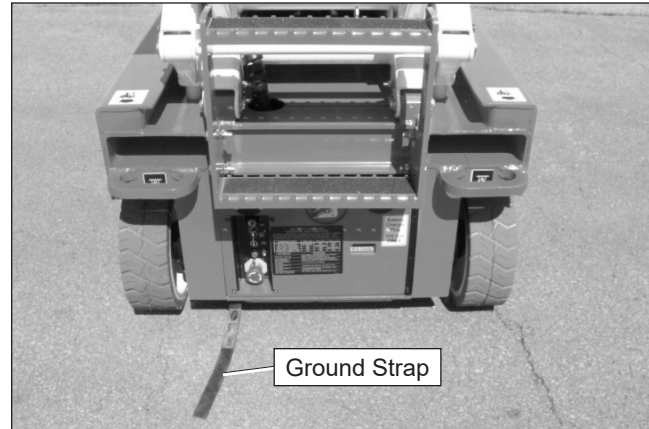

Figure 8.9 – Rear of Chassis

Lower Control Station

With no personnel or materials in the platform, test the operation of each control from the lower controls (refer to Figure 8.10).

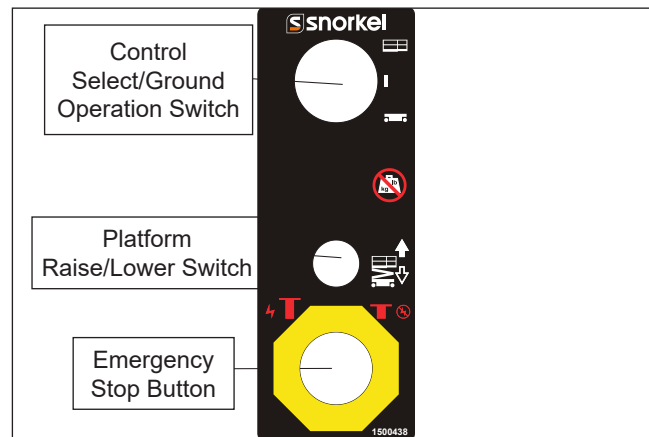

Figure 8.10 – Lower Controls

Operating Controls

Use the following procedure to operate and test the machine from the lower controls:

1. Turn the battery disconnect switch on.
2. Pull the emergency stop switch outward to the on position.
3. Hold the control select/ground operation switch downward in the lower controls position.

⚠ Danger

Pinch points may exist between moving components. Death or serious injury will result from becoming trapped between components, buildings, structures,

or other obstacles. Make sure all personnel stand clear of the aerial platform while performing the prestart inspection.

⚠Warning

The potential for an accident increases when operating an aerial platform that is damaged or malfunctioning. Death or serious injury could result from such accidents. Do not operate the aerial platform if it is damaged or malfunctioning.

4. Test the operation of the platform raise/lower switch in both directions.
5. Place the battery disconnect switch in the off position. The platform should not raise or lower with the disconnect in this position.

Emergency Stop

To test the emergency stop button from the lower controls:

1. Push the emergency stop button inward to turn off electrical power.
2. Test the lower control functions to make sure they do not operate with the emergency stop in this position.

Lowering Alarm

To test the lowering alarm from the lower controls:

1. Raise the platform approximately 10' (3 m).
2. Lower the platform and make sure the alarm sounds.

Pothole Protector Interlock

Perform this test using the lower controls.

1. Stow the aerial platform on a smooth, flat, level concrete slab.
2. Remove all persons and materials from the platform.
3. With the trays closed, check the ground clearance under the pothole protector skids (refer to Figure 8.11). Clearance should be at about 2.63" (6.68 cm) on both sides of the aerial platform.

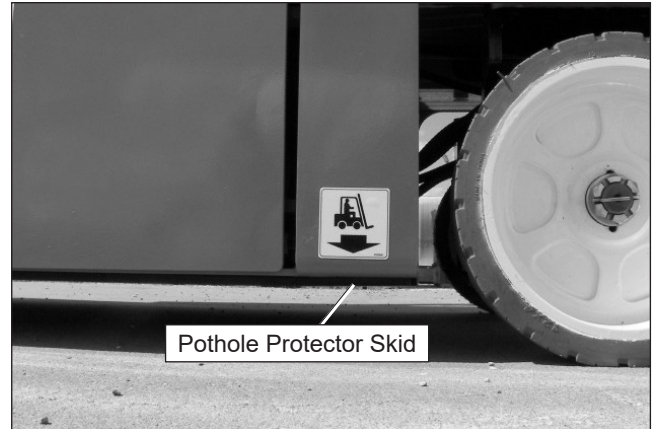

Figure 8.11 – Pothole Protector Skid

4. Raise the platform while watching movement of the skids. The skids should lower to approximately 3/4" (1.9 cm) ground clearance when the platform is raised approximately 24" (61 cm).
5. Fully lower the platform while watching movement of the skids. The skids should raise to their stowed position, with about 2.63" (6.68 cm) ground clearance when the platform is fully lowered.
6. Place a 1 1/2" (3.8 cm) thick board, such as a 2 x 4, under the skid on the left side (refer to Figure 8.12).

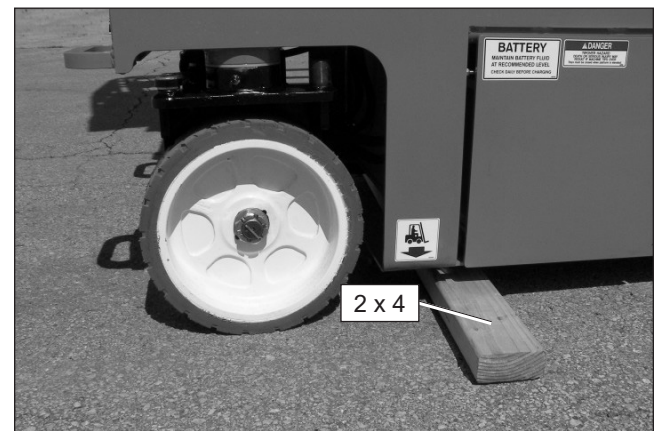

Figure 8.12 – Pothole Protector Skid

7. The board will prevent the skid from lowering fully. Raise the platform. When the skid contacts the board, an alarm should sound at approximately 7' (2 m) platform floor height. The alarm should then sound when the platform lift switch is activated.
8. Lower the platform. Place the board under the skid on the right side.
9. Raise the platform. When the skid contacts the board, an alarm should sound at approximately 7' (2 m) platform floor height. The alarm should then sound when the platform lift switch is activated.

⚠Warning

The potential for an accident increases when safety devices do not function properly. Death or serious injury could result from such accidents. Do not alter, disable, or override any safety device.

10. If the platform raise function is not disabled, or the alarm does not sound remove the aerial platform from service until the problem is corrected.

Emergency Lowering System

Use the following procedure to test the emergency lowering system:

⚠Danger

Pinch points may exist between moving components. Death or serious injury will result from becoming trapped between components. Stand clear of moving components while test operating the machine.

1. Use the lower controls, fully raise the platform. Push the emergency stop button inward.
2. Locate the emergency lowering control.

The lever for the S3215L/S3215E/S3219E is mounted at the front of the aerial platform (refer to Figure 8.13).

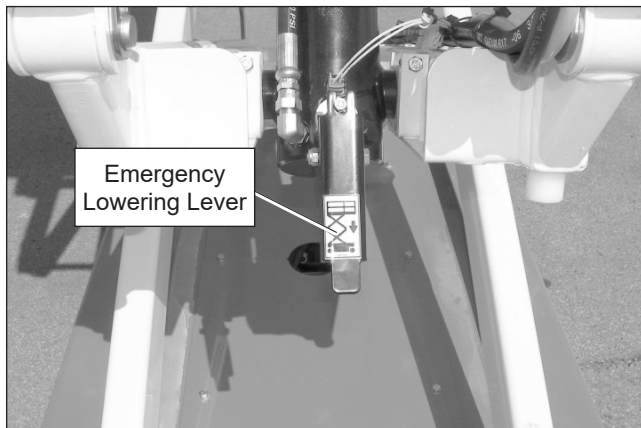

Figure 8.13 – Front of Machine

The handle for the S3220E/S3226E/S4726E/S4732E is mounted at the rear of the aerial platform (refer to Figure 8.14).

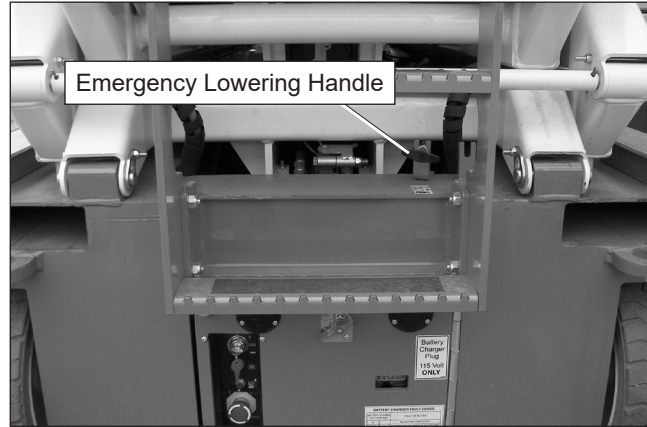

Figure 8.14 – Rear of Machine

⚠Danger

Pinch points may exist between moving components. Death or serious injury will result from becoming trapped between components. Make sure all personnel stand clear while lowering the platform with the emergency lowering lever/handle.

3. Make sure there is nothing in the way to obstruct the platform when it lowers. Stand clear of the scissors structure.
4. Stand clear of the scissors structure.
 - S3215L/S3215E/S3219E – push downward on the emergency lowering lever at the front of the machine to lower the platform.
 - S3220E/S3226E/S4726E/S4732E – pull outward on the emergency lowering handle at the rear of the machine to lower the platform.
5. The platform will begin to lower as the lever/handle is actuated. Release the lever/handle to stop the platform from lowering.

Structures

Visually inspect all weldments and related components. It is important to inspect the fasteners that connect the components.

Weldments

To inspect the weldments:

1. Visually inspect all weldments for abnormal wear, abrasion, or deformation that could cause interference between moving parts.
2. Inspect the welds on the structural components. The area to be inspected should be clean and free of dirt and grease.
3. Look for visible cracks in the welds and at the weld to parent material joints. A bright light may be used to provide adequate visibility of the inspection area.

4. Pay close attention to welds in areas where changes in cross section take place and near the attachment points of highly loaded components.

Rollers and Slide Blocks

To inspect the rollers and slide blocks:

1. Visually inspect the scissors arm rollers and slide blocks (refer to Figure 8.15). They must be free to move without obstruction. There is one roller and slide block on each side of the chassis.

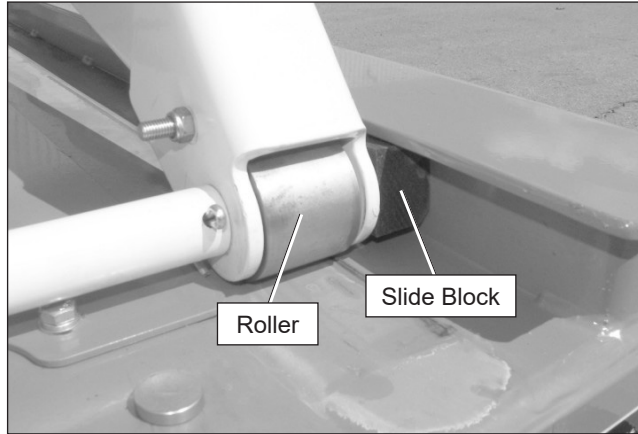

Figure 8.15 – Front of Chassis

2. Raise the platform from the lower controls and visually inspect the slide blocks underneath the front of the platform (refer to Figure 8.16). There is one slide block on each side of the platform. The slide blocks must be in good condition and free to move without obstruction.

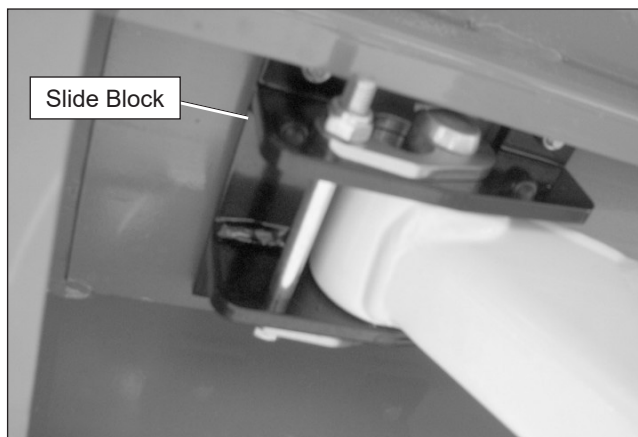

Figure 8.16 – Underneath Front of Platform

Fasteners

To inspect the fasteners:

1. Visually inspect all fasteners to see that none are missing or loose.
2. Inspect all of the bolts, nuts, rollpins, collars, and snap rings. They should all be present, tight, and not damaged in any way.

Upper Control Station

Inspect the platform and upper controls only if all functions operated properly from the lower controls.

Guardrail System

The guardrail system includes (refer to Figure 8.17):

- A top rail
- A mid rail
- Saloon style entry doors
- Toeboards around the sides of the platform.

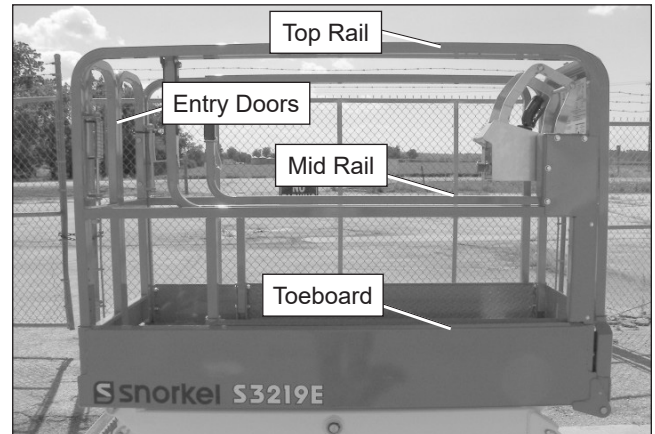

Figure 8.17 – Platform

To inspect the guardrail system:

1. Visually inspect all components of the guardrail system. Make sure the rails and toeboards are all in place and free of any damage or deformation.
2. Visually check the rail and toeboard welds for cracks.
3. Visually check all bolts and nuts fastening the platform and guardrails in place. They must be present and not show any signs of looseness.
4. Inspect the entry doors to see that they swing freely and are not deformed in any way. Make sure the doors are secure when they are closed.

Platform Extension – Foot Activated Deck Lock

A foot released lock on the right side of the extension deck secures the extension deck to the main platform deck. Extension handles may be used to extend or retract the deck after releasing the deck lock.

⚠ Caution

The extension deck is free to move when the deck lock is disengaged. Personal injury may result from accidentally extending or retracting the deck. Make certain the spring latch pin is engaged and locks the deck in position when the deck is extended in the working position and when it is stowed. Do not attempt to extend or retract the platform unless the aerial platform is on a level surface.

To inspect the platform extension:

1. Inspect the extension handles (refer to Figure 8.18) on each side of the platform to ensure they release to extend the platform.

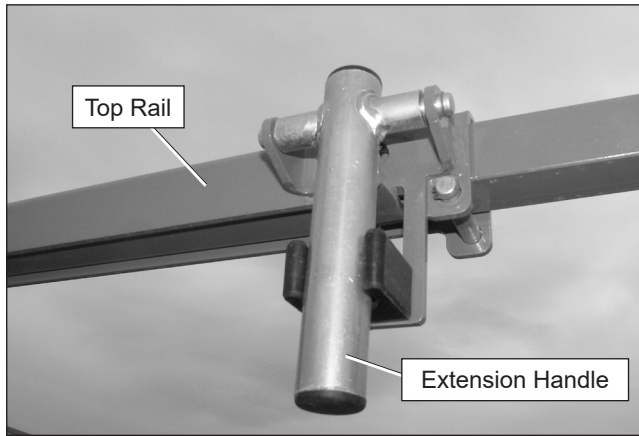

Figure 8.18 – Platform Extension Handle

2. While facing the front of the platform, grasp the platform extension handles and raise them. Step on the deck lock lever (refer to Figure 8.19) to release the spring latch and push the extension deck forward to verify the deck locks into the mid and front positions. Fully lower the handles and ensure they are locked in their stowed position.

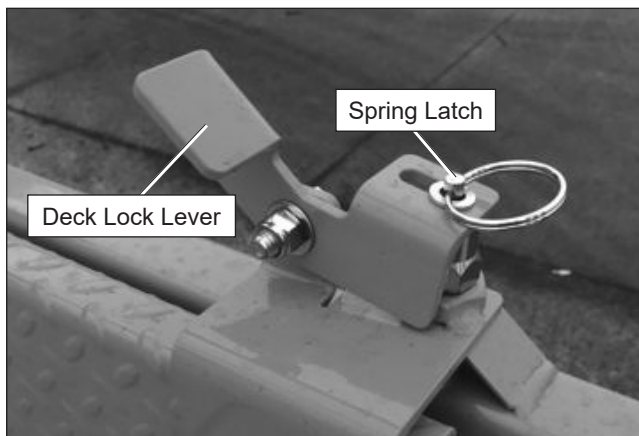

Figure 8.19 – Platform Extension Deck Lock

3. Inspect the rollers on the platform extension. They must be in place, in good condition, and free to move without obstruction.
4. Inspect the weldments for deformation and damage. Try to move the rails back and forth to make sure the platform extension deck fully locks in position.
5. Visually check the platform welds for cracks.
6. While facing the front of the platform, grasp the platform extension handles and raise them. Step on the deck lock lever (refer to Figure 8.19) to release the spring latch pin and pull the extension deck backward

to retract the deck. Make sure the platform extension deck is locked in position.

7. Fully lower the handles and ensure they are locked in their stowed position (refer to Figure 8.18).

Platform Extension – Handle Lock

Latch handles on each side of the extension deck secures the extension deck to the main platform deck.

⚠ Caution

The extension deck is free to move when the extension handle locks are disengaged. Personal injury may result from accidentally extending or retracting the deck. Make certain both extension handle locks are fully engaged when the deck is extended in the working position and when it is stowed. Do not attempt to extend or retract the platform unless the aerial platform is on a level surface.

To inspect the platform extension:

1. Inspect the extension handles and locks (refer to Figure 8.20) on each side of the platform to ensure they release to extend the platform.

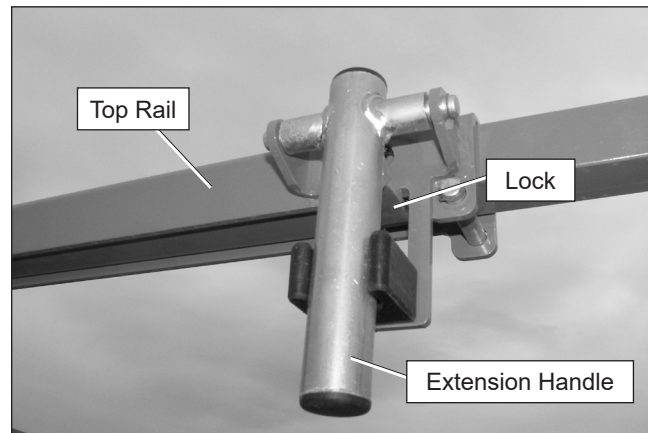

Figure 8.20 – Platform Extension Handle

2. While facing the front of the platform, grasp the platform extension handles, raise them and push the extension deck forward to extend the deck. Fully lower the handles at the mid or front position and ensure they are locked in their lowered position (refer to Figure 8.20).
3. Inspect the rollers on the platform extension. They must be in place, in good condition, and free to move without obstruction.
4. Inspect the weldments for deformation and damage. Try to move the rails back and forth to make sure the platform extension deck fully locks in position.
5. Visually check the platform welds for cracks.

6. While facing the front of the platform, grasp the platform extension handles, raise them and pull the extension deck backward to retract the deck. Fully lower the handles at the stowed position and ensure they are locked in the lowered position (refer to Figure 8.20).

7. Make sure the platform extension deck is locked in position.

Operating Controls

Warning

The potential for an accident increases from improperly driving or steering the aerial platform. Death or serious injury could result from such accidents. Make sure the upper control panel is securely fastened inside the platform and facing the front of the machine.

Avoid driving the platform with the upper controls facing the rear or side of the machine. In this position the machine is difficult to control because the drive and steer control movements and their resulting machine movements will not correspond.

Only operate the upper controls when the upper control panel is securely fastened inside the platform and facing the front of the machine.

Use the following procedure to operate and test the machine from the upper controls:

1. Make sure the battery disconnect is turned on.
2. At the lower controls, pull the emergency stop button outward.
3. Turn the control select/ground operation switch to the upper control position.
4. At the upper controls (refer to Figure 8.21), pull the emergency stop button outward.

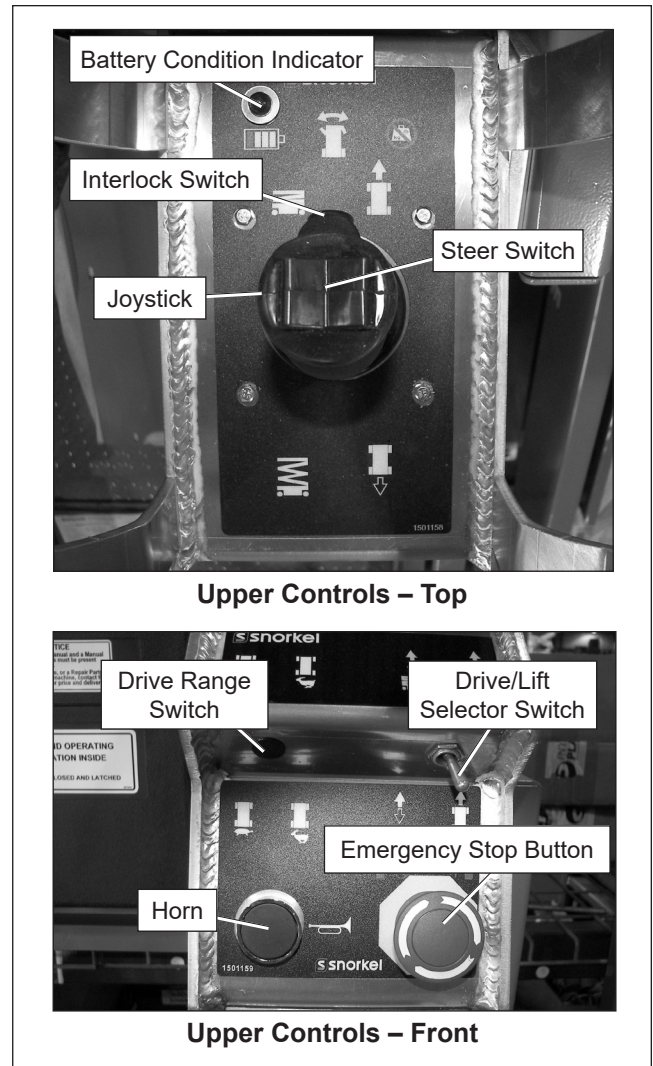

Figure 8.21 – Upper Controls

Warning

The potential for an accident increases when operating an aerial platform that is damaged or malfunctioning. Death or serious injury could result from such accidents. Do not operate the aerial platform if it is damaged or malfunctioning.

5. Test the interlock switch by moving the joystick without engaging the interlock switch.

If movement occurs, the interlock is not functioning properly. Do not operate the machine until the problem is corrected.

6. Place the drive/lift selector switch in the drive position and test the operation of the joystick in both directions. The lift functions should not operate with the selector in the drive position.

Squeeze and hold the interlock switch against the joystick. Test the steer switch in both directions using the steering switch.

- To steer to the right, hold down the right side of the steer switch.
 - To steer to the left, hold down the left side of the steer switch.
7. Test the operation of the brakes while operating the aerial platform from the upper controls. The brakes are engaged when:
- the joystick interlock is released.
 - the drive/lift selector switch is in the lift position.
 - the emergency stop button is pushed down.

Placing the drive/lift selector in the drive position, engaging the interlock and moving the joystick, releases the brakes.

8. Place the drive/lift selector switch in the lift position and test the operation of the joystick in both directions. The drive functions should not operate with the selector in the lift position.

Squeeze and hold the interlock switch against the joystick. Test the joystick in both directions.

- To raise the platform, pull the joystick backward.
- To lower the platform, push the joystick forward.

Emergency Stop

To test the emergency stop button from the upper controls:

1. Push the emergency stop button inward to turn off electrical power.
2. Verify that the upper control platform and drive functions do not operate.

Horn Button

The horn is operational when the machine is set up for operation from the upper control panel (refer to Figure 8.21).

Press the horn button to ensure that it sounds to warn personnel in the area.

Lowering Alarm

To test the lowering alarm from the upper controls:

1. Raise the platform approximately 10' (3 m).
2. Lower the platform and make sure the alarm sounds.

Drive Alarm

Drive in both the forward and reverse directions to ensure that the alarm sounds to warn personnel in the area that the aerial platform is in motion.

Electrical Power Outlet

Connect a source of 125 volt AC power to the power-input connector at the rear of the chassis. Plug an electrical tool into the receptacle and try to operate the tool to verify proper operation of the outlet.

Use the following procedure to test the ground fault circuit interrupter GFCI.

1. Push the test button (refer to Figure 8.22).

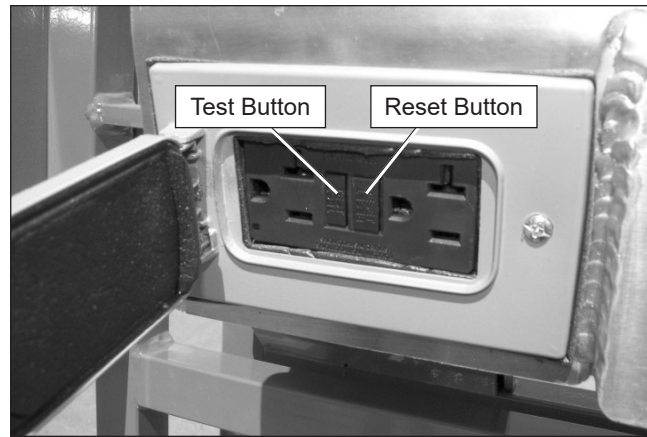

Figure 8.22 – Electrical Power Outlet

2. Plug an electrical tool into the outlet and verify the power is off.
 - If the power was off, push the reset button to restore power.
 - If the power was on, repair or replace the receptacle.

Flashing Light

The machine may be equipped with an optional flashing light located under the upper control box.

To inspect the flashing light:

1. At the lower controls, pull the emergency stop button outward and turn the control select/ground operation switch to either the lower or upper control position.
2. Operate any control function and visually check to see that the light is flashing approximately one flash per second.

Note

There is not an off switch for the flashing light.

Perimeter Lights

The machine may be equipped with optional perimeter lights at the front, rear, and both sides of the machine.

To inspect the perimeter lights:

1. At the lower controls, pull the emergency stop button outward and turn the control select/ground operation switch to the upper control position.
2. At the upper controls, pull the emergency stop button outward and engage the interlock switch on the upper controls or the interlock button on the loading controls and visually check to see that the lights are operational.

Note

There is not an off switch for the perimeter lights.

Pipe Rack

The machine may be equipped with an optional pipe rack attached to the left side of the platform guardrails.

To inspect the pipe rack:

1. Visually inspect the mounting plates for abnormal wear, abrasion, or deformation.
2. Visually inspect all fasteners to see that none are missing or loose. They should all be present, tight, and not damaged in any way.
3. Visually inspect the nylon straps. They should both be present and not damaged in any way. Inspect the cam-lock fasteners to ensure they securely engage and release the strap.

Panel Carrier

The machine may be equipped with an optional panel carrier attached to the right side of the platform.

To inspect the panel carrier:

1. Visually inspect the mounting clamps for abnormal wear, abrasion, or deformation.
2. Visually inspect all fasteners to see that none are missing or loose. They should all be present, tight, and not damaged in any way.
3. Visually inspect the panel tray and hook. They should both be present and not damaged in any way. Inspect the hook to ensure it fully lowers to secure a panel when placed in the tray.

Placards and Decals

To inspect the placards and decals:

1. Inspect all safety and operational placards and decals. Make certain they are in place, in good condition, and are legible.
2. Clean the placards and decals with soap and water, and a soft cloth if the words or pictures cannot be seen.

Caution

Solvents may contain hazardous ingredients. Follow the manufacturer's label for proper use and disposal. Wear protective gloves and splash-proof safety glasses when using solvents.

3. Remove wet paint overspray with a natural biodegradable solvent and a soft cloth.
4. Replace any missing, damaged, or illegible placards or decals before operating the aerial platform.

Placard and decal kits are available from Snorkel.

Safety related placards and decals are illustrated on the following pages. Refer to the appropriate decal page in the machine parts manual for specific operational and safety placards and decals.

▲ DANGER

Proper position for safety prop use:

Death or serious injury might result if safety prop is not used and/or properly positioned. Use safety prop at all times when servicing machine with platform raised.

PROPER USE OF SAFETY PROP

1. Remove all material from platform.
2. Raise platform until the open height is wide enough to position the safety prop.
3. Place safety prop in the proper position.
4. Remove hands and arms from scissors area.
5. Lower platform until scissors are supported by safety prop.

TO STORE SAFETY PROP

1. Raise platform until the open height is wide enough to position the safety prop.
2. Place the safety prop in the storage position.

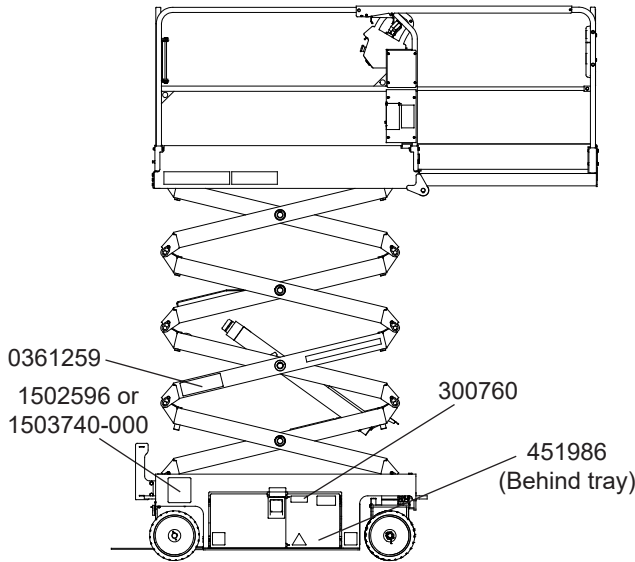

Right Side

▲ WARNING

DEATH OR SERIOUS INJURY COULD RESULT FROM UNCONTROLLED MOTION.

Towing this machine requires disengaging the brakes. Follow instructions below when towing, pushing, or winching this machine. Verify the brakes have been reset after moving machine and before operating the machine.

TOWING INSTRUCTIONS

1. Before towing, pushing, or winching, the machine must be on level ground. Read and understand all instructions. Refer to the Operator's Manual. Turn battery disconnect switch to "OFF" position.
2. Turn the brake release/free-wheeling valve clockwise to the fully closed position.
3. Push and release the brake release pump several times to release the brakes.
4. **DO NOT** exceed 2 mph (3.2 km/h) when towing.
5. After moving the machine, turn the brake release/free-wheeling valve fully counterclockwise. Operate the drive function to verify that the brakes reset.

DISENGAGE BRAKES

Brake Release Pump
Brake Release/Free-Wheeling Valve

HYDRAULIC MANIFOLD VALVE 1503740-000

0361259

1503740-000

▲ DANGER

TIPOVER HAZARD
DEATH OR SERIOUS INJURY MAY RESULT IF MACHINE TIPS OVER
Trays must be closed when platform is elevated.

300760

300760

▲ DANGER

DO NOT ALTER OR DISABLE LIMIT SWITCHES, SAFETY SWITCHES, OR INTERLOCKS.

451986

451986

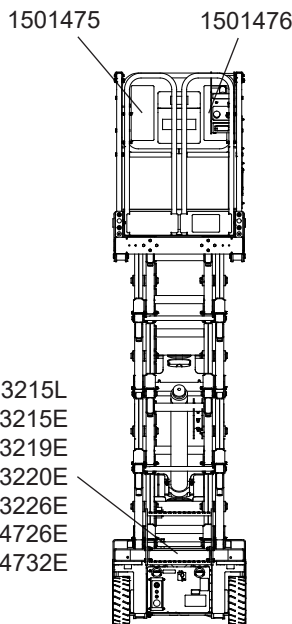

Rear

- 1502773 – S3215L
- 1502777 – S3215E
- 1502598 – S3219E
- 1502777 – S3220E
- 1502774 – S3226E
- 1502775 – S4726E
- 1502776 – S4732E

▲ DANGER

DEATH OR SERIOUS INJURY WILL RESULT FROM TIPPER OVER. TO KEEP FROM TIPPER THIS MACHINE OVER FOLLOW THESE RULES.

DO NOT RAISE OR DRIVE AN ELEVATED PLATFORM ON A SLOPE

DO NOT RAISE THIS PLATFORM MORE THAN 4 FEET (1.2 M) TO ANY DROP OFF OR HOLE

OTHER ACTIONS CAN ALSO CAUSE THIS MACHINE TO TIP OVER

DO NOT invert safety devices.
DO NOT overload the machine.
DO NOT stand or sit on guardrails.
DO NOT attach ropes or chains to guardrails.
DO NOT carry loads outside the rating or use as a crane.

ALARM MEANS TIPPER DANGER LOWER PLATFORM IMMEDIATELY

ELECTRICAL SHOCK CAN KILL YOU
This machine is not electrically insulated. Maximum lift height 22.5 ft (6.86 m) maximum. Maximum platform height 22.5 ft (6.86 m) maximum. An accident could cause injury or death. This machine will not protect you from shock.

DO NOT use this machine without the settings and the safety pins, chain or bar in place. You could be hit and hurt or killed.

DO NOT use this machine if it is not working right, or if any part of it is damaged, loose, or missing. An accident could cause injury or death.

NOTE: STUDY THE OPERATOR'S MANUAL BEFORE OPERATING THIS MACHINE.

1501475

▲ DANGER

DEATH OR SERIOUS INJURY WILL RESULT FROM TIPPER OVER. TO KEEP FROM TIPPER THIS MACHINE OVER FOLLOW THESE RULES.

DO NOT RAISE OR DRIVE AN ELEVATED PLATFORM ON SOFT OR UNEVEN SURFACES

DO NOT RAISE THE PLATFORM IN WIND ABOVE 20 MPH (12.5 M/S)

OTHER ACTIONS CAN ALSO CAUSE THIS MACHINE TO TIP OVER

DO NOT use platform while machine is on a truck, fork lift or other device.
DO NOT use ladder, scaffold, or other means to increase use or platform height.
DO NOT use with damaged tires or wheels.

TO AVOID TIPPER HAZARDS USE ON FLAT LEVEL AND SOLID SURFACES ONLY

ELECTRICAL SHOCK CAN KILL YOU
After an electrical shock, even if it is not fatal, you should seek medical attention. If you have a heart condition, you should consult your physician or read the Operator's Manual for this machine for more information.

DO NOT use an untrained or unqualified person use this machine. Only trained and qualified personnel should operate this machine. When leaving the machine unattended, remove the key, turn the battery disconnect switch off, and lock the lift platform.

DO NOT remove components critical to machine stability, such as ball joints and axles, with lighter weight or non-factory approved substitutes.

NOTE: STUDY THE OPERATOR'S MANUAL BEFORE OPERATING THIS MACHINE.

1501476

snorkel		www.snorkellifts.com		Snorkel International, LLC 2909 Riverport Road Elwood, KS 66024		Snorkel International, LLC 8300 Eastgate Road Henderson, NV 89015	
MODEL NUMBER	S3219E ANSI	MAXIMUM PLATFORM HEIGHT	19 ft 5.8 m	S/N		SLOPE SENSOR ALARM SETTING	
MONTHLY YEAR OF MANUFACTURE		RATED NUMBER OF OCCUPANTS	Indoors 2 Outdoors 1	FRONT TO BACK	4 deg	SIDE TO SIDE 2 deg	
EMPTY VEHICLE WEIGHT	2900 lbs 1318 kg	MAXIMUM DRIVE HEIGHT	19 ft 5.8 m	MAXIMUM LOAD	1450 lbs 658 kg		
MAXIMUM GRADEABILITY	25 %	UNRESTRICTED CAPACITY	550 lbs 250 kg	BATTERIES	6 V	MOTOR 24 V	
MAXIMUM ALLOWABLE MANUAL FORCE (SIDE PULL)	90 lbs 40.5 kg	MAXIMUM WIND SPEED	12.5 m/s	CHARGER INPUT	220 V	120/240 V	
CAUTION							
Do not remove any weight from this machine.							
				1-800-255-4317		1502598	

1502773/1502777/1502598/1502774/1502775/1502776

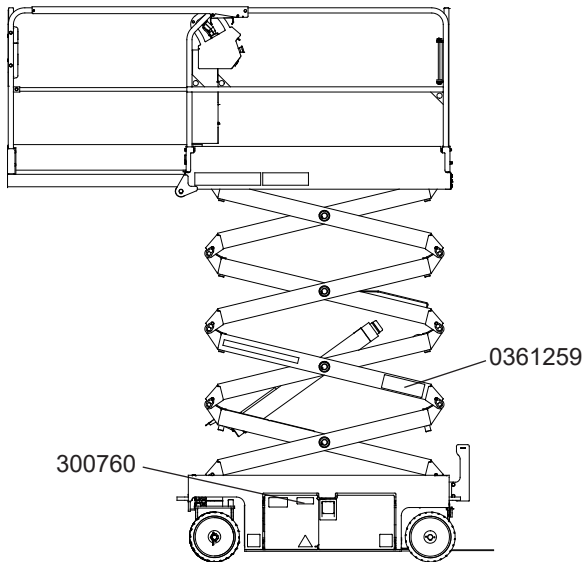

Left Side



300760

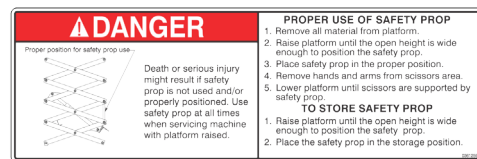

0361259

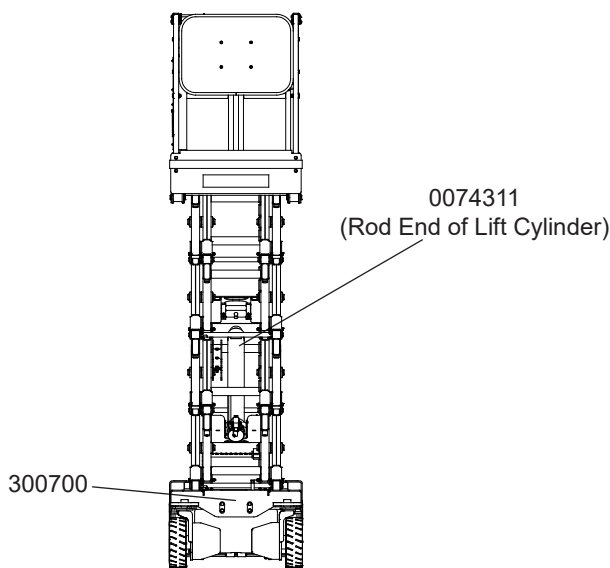

Front



0074311



300700

Prestart Inspection Checklist

Item	Inspect For	P	F	R
Operator's Manual	In manual holder, all pages readable and intact			
Electrical System				
Battery fluid level	Proper level			
Battery terminals	Clean, connectors tight			
Battery charger	Proper operation			
Cables and wiring harness	No wear or physical damage			
Hydraulic System				
Fluid level	Visible in sight glass/on dipstick with platform stowed			
Hoses, tubes and fittings	No leaks, all fittings tight			
Free-wheeling valve	In normal operation position. Side mount CW/Back mount CCW			
Diagnostic Center Display	Displays operating time/battery power			
Tires and Wheels	Good condition			
Ground Strap	In place and securely fastened			
Lower Control Station				
Operating controls	Proper operation			
Emergency stop	Shuts off lower controls/proper operation			
Lowering alarm	Sounds when platform lowers			
Lowering interrupt – CE/AS/NZS	Sounds when platform lowers/proper operation			
Pothole Protection Interlock	Proper operation			
Emergency Lowering	Proper operation			
Safety Prop	No damage or deformation			
Flashing/Perimeter Light – option	Proper operation			
Pipe Rack – option	No damage or deformation. Proper operation			
Panel Carrier – option	No damage or deformation. Proper operation			
Snorkel Guard – option	No damage or deformation. Proper operation			
Bumpguard – option	No damage or deformation. Proper operation			
Airline to platform – option	No damage or deformation. Proper operation			
Inverter – option	No damage or deformation. Proper operation			
Structures				
Weldments – Chassis/platform/etc.	Welds intact, no damage or deformation			
Rollers and slide blocks	In place, no damage or deformation			
Fasteners	In place, tight, and no damage			
Upper Control Station				
Guardrail system	Welds intact, no damage or deformation All fasteners in place, no loose or missing parts			
Platform extension lock(s)/handles	Proper operation, no damage or deformation			
Brakes	Proper operation			
Operating controls	Proper operation			
Emergency stop	Shuts off upper controls			
Lowering alarm	Sounds when platform lowers			
Drive motion alarm	Sounds when aerial platform drive function is operated			
Battery condition indicator	Proper operation			
Horn	Sounds when activated			
Placards and Decals	In place and readable			

Maintenance Table Key: P = Pass, F = Fail, R = Repaired

Performed by: _____ Date: _____

Model: _____ Serial Number: _____

Chapter 9 – Operation

The aerial platform may be operated from either the lower or upper controls.

⚠ Danger

The aerial platform is not electrically insulated. Death or serious injury will result from contact with, or inadequate clearance from, an energized conductor. Do not go closer than the minimum safe approach distance as defined by ANSI or national safety regulations.

Pinch points may exist between moving components. Death or serious injury will result from becoming trapped between components, buildings, structures, or other obstacles. Make sure there is sufficient clearance around the machine before moving the chassis or platform. Allow sufficient room and time to stop movement to avoid contact with structures or other hazards.

The aerial platform can tip over if it becomes unstable. Death or serious injury will result from a tip-over accident. Operate the aerial platform on a firm, flat, level surface. Avoid travel speeds and/or rough terrain that could cause sudden changes in platform position. Do not drive or position the aerial platform for elevated use near any drop-off, hole, slope, soft or uneven ground, or other tip-over hazard. Do not operate the aerial platform in unapproved locations or wind conditions. Do not raise the platform in wind speeds above 28 mph (12.5 m/s).

The platform rated work load is the total weight of the personnel and equipment that may be lifted in the platform.

The work loads are stated on the platform rating placard at the entrance to the platform.

⚠ Danger

The aerial platform can tip over if it becomes unstable. Death or serious injury will result from a tip-over accident. Do not exceed the capacity values indicated on the platform rating placard.

Capacity values indicate the rated lifting capacity and do not indicate aerial platform stability.

The operator bears ultimate responsibility for ensuring that the aerial platform is properly set up for the particular conditions encountered.

Preparing for Operation

Use the following procedure to prepare the aerial platform for operation:

1. Perform a prestart inspection (refer to Chapter 8).
2. Place the battery disconnect switch in the on position.
3. Close and latch the swing-out trays.

Lower Controls

Only the platform raise and lower functions may be operated from the lower controls. The lower controls may be used for initial set up of the aerial platform, and for testing and inspection.

Use the following procedure to raise or lower the platform using the lower controls.

1. Pull the emergency stop button outward (refer to Figure 9.1).

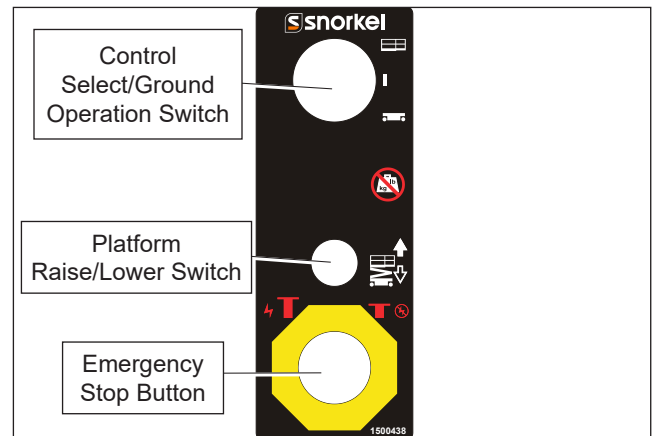

Figure 9.1 – Lower Controls

2. Insert the key into the control selector/ground operation switch and turn the switch to the lower controls position. Hold the switch in the lower controls position.
3. Hold the control select/ground operation switch downward in the lower controls position.
4. Hold the platform raise/lower toggle switch up to raise the platform and down to lower it.
5. Release either switch to stop movement.

Upper Controls

The upper controls may be used for driving and positioning the aerial platform while on the job.

Before operating the upper controls, properly set up the aerial platform as described under Preparing for Operation.

Use the following procedure to operate the aerial platform from the upper controls:

1. From the lower controls, pull the emergency stop button outward (refer to Figure 9.1).
2. Insert the key into the control selector switch and turn the switch to the upper controls position.
3. Switch the control select/ground operation switch upward to the upper controls position.

Note

The upper controls will not operate while the control selector is in the lower position.

4. Enter and exit the platform using three points of support. Grasp the handrails, not the doors, with one hand on each side. Use two hands and one foot on the step when climbing into and out of the platform.
5. From the upper controls, pull the emergency stop button outward (refer to Figure 9.2).

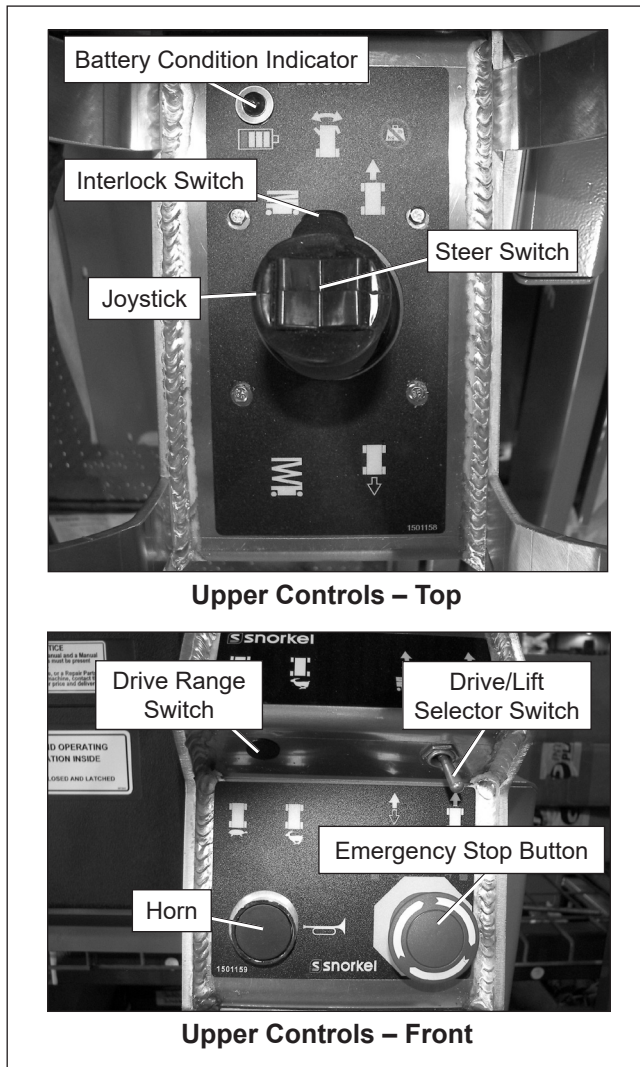

Figure 9.2 – Upper Controls

6. The aerial platform may be driven and the platform may be raised and lowered from the upper controls.

Push the emergency stop button inward when the upper controls are not in use to protect against unintentional operation.

Removable Upper Controls/Side Drive

An optional removable upper control box or a side drive pendant may be provided on the machine.

⚠ Danger

Pinch points may exist between moving components. Death or serious injury will result from becoming trapped between components, buildings, structures, or other obstacles. Maintain at least 39" (1 m) clearance around the machine before moving the chassis or platform. Allow sufficient room and time to stop movement to avoid contact with structures or other hazards.

Maintain at least 39" (1 m) between yourself and the aerial platform when operating either the removable upper controls or the side drive pendant from the ground outside of the platform.

Platform

Use three points of support when entering or exiting the platform. Grasp the handrails, not the doors, with one hand on each side. Use two hands and one foot on the step when climbing into and out of the platform.

Use care when entering and exiting the platform to avoid slipping and/or falling. Securely close the entry doors when the platform is occupied.

⚠ Danger

The potential for an accident increases when the fold down rails are lowered. Death or serious injury will result in such accidents. Do not elevate the platform with the fold down rails lowered. Use extreme care when moving the aerial platform while the fold down rails are lowered.

If the machine is equipped with fold down guardrails, be sure they are up and their hardware is securely tightened, anytime the machine is not being transported.

Raising and Lowering

The raise speed is proportional to the joystick position. The farther the joystick is moved, the faster the platform raises. There is only one lowering speed.

1. Place the drive/lift selector switch (refer to Figure 9.2) in the lift position.
2. Squeeze and hold the interlock switch against the joystick.
 - To raise the platform, slowly pull the joystick backward until the desired height is reached.
 - To lower the platform, push the joystick forward.

Lowering Interrupt – CE/AS/NZS

When the platform is lowered to about 6' (1.8 m) lowering stops, the flashing light is constant on and the alarm sounds in fast short beeps. The platform will not lower for five seconds regardless of the joystick position.

Center the control in neutral to reset the lowering function, then continue to lower the platform.

When the platform is below 6' (1.8 m) and the control is moved to lower the platform, there is a 1.5 second delay before movement begins.

Overload Protection

When the load in the platform is near or at rated capacity, an alarm will sound and the red light on the lower controls will flash.

The alarm and light warn the operator that the platform is close to becoming overloaded. All functions remain fully operational.

⚠ Danger

The aerial platform can tip over if it becomes unstable. Death or serious injury will result from a tip-over accident. Do not exceed the capacity values indicated on the platform rating placard.

If the platform is overloaded, when it is elevated just past 6' (1.8 m), a control module will stop the lift and drive functions and the alarm will slowly beep and the warning light will be on. The platform can still be lowered to remove the excess load using the upper controls or the emergency lowering system only.

If the platform is elevated just past 6' (1.8 m) and material is added to the platform overloading it, a control module will stop the lift, drive and lower functions. The alarm will slowly beep and the warning light will be on. In this case, remove the load in excess of rated capacity to return to normal operation.

If the emergency lowering lever/handle is activated when the platform is overloaded, the lower controls will not operate and the LCD will display "Function Locked Emergency Lowering Detected." In this case, remove the load in excess of rated capacity and enter the pass code on the LCD keypad to return to normal operation.

Extending – Foot Activated Deck Lock

The platform can be extended and securely locked into position.

Use the following procedure to extend the platform:

1. Enter the platform and secure the doors.

⚠ Caution

The extension deck is free to move when the deck lock is disengaged. Personal injury may result from accidentally extending or retracting the deck. Make certain the spring latch pin is engaged and locks the deck in position when the deck is extended in the working position and when it is stowed. Do not attempt to extend or retract the platform unless the aerial platform is on a level surface.

2. While facing the front of the platform, grasp the platform extension handles and raise them. Step on the

deck lock lever (refer to Figure 9.3) to release the spring latch and push the extension deck forward and lock it into either the mid or front position.

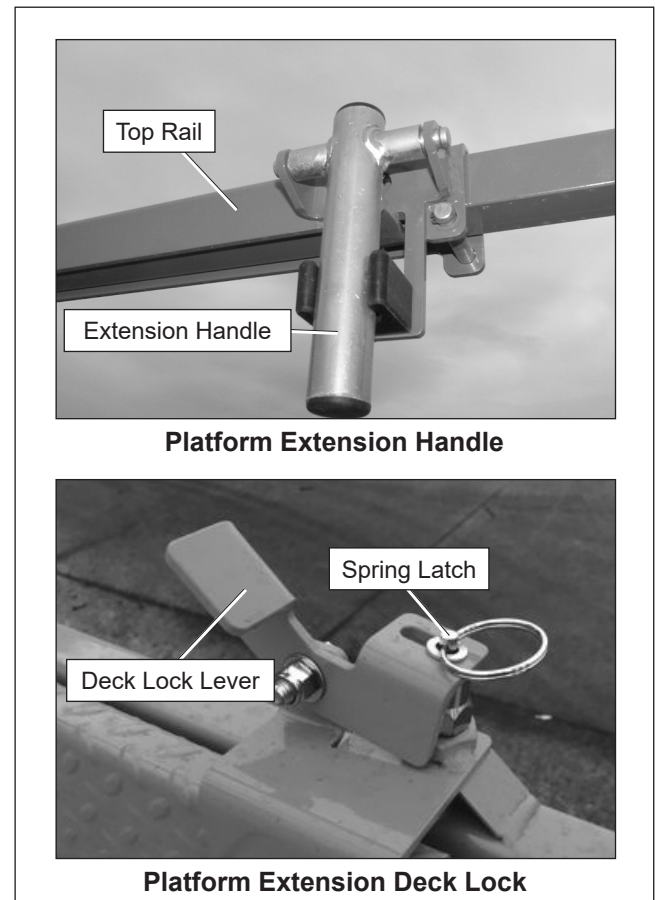

Figure 9.3 – Platform Extension Handle and Lock

3. Try to move the rails back and forth to make sure the platform extension deck is locked in position. Fully lower the handles and ensure they are locked in their stowed position.

Use the following procedure to retract the platform:

1. Enter the platform and secure the doors.

⚠ Caution

The extension deck is free to move when the deck lock is disengaged. Personal injury may result from accidentally extending or retracting the deck. Make certain the spring latch pin is engaged and locks the deck in position when the deck is extended in the working position and when it is stowed. Do not attempt to extend or retract the platform unless the aerial platform is on a level surface.

2. While facing the front of the platform, grasp the platform extension handles and raise them. Step on the deck lock lever (refer to Figure 9.3) to release the spring latch pin and pull the extension deck backward to retract the deck. Try to move the rails back and forth

to make sure the platform extension deck is locked in position.

3. Fully lower the handles and ensure they are locked in their stowed position.

Extending – Handle Lock

The platform can be extended and securely locked into position.

Use the following procedure to extend the platform:

1. Enter the platform and secure the doors.

⚠Caution

The extension deck is free to move when the extension handle locks are disengaged. Personal injury may result from accidentally extending or retracting the deck. Make certain both extension handle locks are fully engaged when the deck is extended in the working position and when it is stowed. Do not attempt to extend or retract the platform unless the aerial platform is on a level surface.

2. While facing the front of the platform, grasp the platform extension handles, raise them and push the extension deck forward to extend the deck. Fully lower the handles at the mid or front position and ensure they are locked in their lowered position (refer to Figure 9.4).

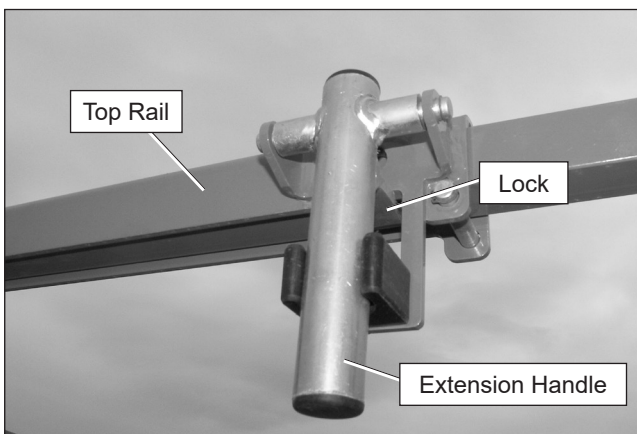

Figure 9.4 – Platform Extension Handle

3. Try to move the rails back and forth to make sure the platform extension deck is locked in position.

Use the following procedure to retract the platform:

1. Enter the platform and secure the doors.

⚠Caution

The extension deck is free to move when the extension handle locks are disengaged. Personal injury may result from accidentally extending or retracting the deck. Make certain both extension handle locks are

fully engaged when the deck is extended in the working position and when it is stowed. Do not attempt to extend or retract the platform unless the aerial platform is on a level surface.

2. While facing the front of the platform, grasp the platform extension handles, raise them and pull the extension deck backward to retract the deck. Fully lower the handles at the stowed position and ensure they are locked in the lowered position (refer to Figure 9.4).
3. Try to move the rails back and forth to make sure the platform extension deck is locked in position.

Fold Down Guardrails

The platform may have fold down guardrails to pass the machine under low height obstructions.

⚠Danger

The potential for an accident increases when the fold down rails are lowered. Death or serious injury will result in such accidents. Do not elevate the platform with the fold down rails lowered. Use extreme care when moving the aerial platform while the fold down rails are lowered.

Use the following procedure to lower the platform guardrails.

1. Remove all materials from the platform floor and slightly extend the extension deck.
2. Remove the pin from the hinged top rail on the extension deck. Fold the hinged rail in as far as it will go.
3. Lift the left hand extension deck rail up and fold it down inwards.
4. Remove the pin from the hinged top rail on the main deck. Fold the hinged rail in as far as it will go.
5. Lift the left hand main deck rail up and fold it inwards.
6. Lift the right hand extension deck rail up and fold it down inwards.
7. Lift the right hand main deck rail up and fold it inwards.
8. Reverse this procedure to reposition the rails.

Driving and Steering

⚠Danger

The aerial platform can tip over if it becomes unstable. Death or serious injury will result from a tip-over accident. Do not drive an elevated aerial platform on soft, uneven, or sloping surfaces. Do not drive on grades that exceed 25 percent.

A fully stowed machine may be operated on grades up to 25 percent. A grade of 25 percent is a 30" (0.76 m) vertical rise in 10' (3.05 m) horizontal length.

⚠Warning

Death or serious injury could result from improperly driving or steering the aerial platform. Read and understand the information in this manual and on the placards and decals on the machine before operating the aerial platform on the job.

Use the following procedure to operate the drive and steer functions.

1. Place the drive/lift selector switch (refer to Figure 9.2) in the drive position.
2. Squeeze and hold the interlock switch against the joystick.
3. Push the drive joystick forward to move the chassis forward. Pull the joystick backward to move the chassis backward. The drive speed is proportional to the joystick position.
4. To stop drive motion, return the joystick to neutral.

Note

To make an emergency stop push the emergency stop button inward to apply the parking brakes.

5. The steer switch is a momentary contact, rocker switch on top of the drive joystick. This switch controls the two front wheels to steer the aerial platform.
 - To steer to the right, hold down the right side of the steer switch.
 - To steer to the left, hold down the left side of the steer switch.

Note

Holding the steer switch down too long may result in a sharp turn. This is especially true when driving and steering at the same time. It may be easier to turn the wheels in small increments using a series of quick taps on the steer switch.

6. Set the steer wheels straight ahead after completing a turn. The steering wheels are not self-centering.

Drive Range Switch

The drive range switch has two positions to select drive wheel operation:

- High (Rabbit) – for normal driving conditions.
- Low (Turtle) – for driving on grades up to 25 percent that require low speed and high torque operation, where high range is not sufficient to climb the grade.

Note

Some early model S3219E and S3220E machines were not equipped with a drive range switch.

In high the machine will travel up to 2 mph (3.2 km/h) when the platform is raised less than 8' (2.4 m) and up to 0.5 mph (0.8 km/h) when the platform is raised above 8' (2.4 m). Place the drive range switch in high for normal machine operation.

⚠Caution

The extension deck is free to move when the extension deck lock(s) are disengaged. Personal injury may result from accidentally extending or retracting the deck. Make certain the extension lock(s) are fully engaged when the deck is extended in the working position and when it is stowed. Do not attempt to extend or retract the platform unless the aerial platform is on a level surface.

Place the drive range switch in low, with the platform fully lowered and the extension deck locked in the stowed position, before driving up a ramp to load the machine for transport.

If driving the machine, come to a complete stop before switching from Low to High drive range.

Drive Speeds

The drive speed is proportional to the joystick position. The farther the joystick is moved, the faster the travel speed.

Always slow down before traveling over rough terrain or any sloped surface.

Drive speed ranges are interlocked through limit switches that sense the platform position.

- When the platform is elevated below approximately 6' (1.8 m) the aerial platform may be driven with the full range of drive speeds.
- When the platform is elevated above 6' (1.8 m) only the slowest drive speed will work.

⚠Warning

The potential for an accident increases when safety devices do not function properly. Death or serious injury could result from such accidents. Do not alter, disable, or override any safety device.

Do not use the aerial platform if it drives faster than 0.4 mph (0.6 km/h), which is 7' 7" (5.3 m) in 30 seconds, when elevated above 6' (1.8 m).

Drive/Lift Pothole Protector Interlock

The aerial platform drive and lift functions are interlocked through a limit switch that senses whether or not the pothole protection linkage is locked into position. The drive/lift pothole interlock operates when the platform is elevated approximately 6' (1.8 m).

If an obstruction under the skids, or some other impairment prevents the skids from locking into position, the drive and steer functions will not operate.

Lower the platform and remove the obstruction when the drive/lift pothole protector interlock is engaged.

Drive/Lift Level Sensor Interlock

When the platform is elevated above 6' (1.8 m), drive and lift functions are interlocked through a level sensor system.

The drive and lift functions will not operate and an alarm will sound if the chassis is tilted more than the factory preset level sensor value. The setting for the degree of slope, side-to-side and front-to-rear, varies depending on the requirements of the applicable governing body (ANSI, CSA, CE, AS, NZS) that the machine was manufactured to conform to.

Refer to the machines General Specifications for the drive/lift level sensor interlock level sensor values.

If the drive/lift level sensor interlock shuts off the platform raise and drive functions, lower the platform and drive to a level surface.

Progressive Tilt

The progressive tilt system allows the machine to be operated on greater side-to-side slopes when the platform is below maximum rated height. As the platform is elevated, the degree of side-to-side slope the machine may be operated on decreases. Refer to Appendix D – Progressive Tilt to determine the relationship between platform height and degree of slope for specific machine models.

S3226E machines with the following serial numbers are equipped with a progressive tilt system:

- S3226E-04-190501073 and after
- S3226E-01-190100398 and after

All other scissor machines manufactured June 2020 and after are equipped with progressive tilt.

Swing-Out Trays

Batteries and hydraulic components are enclosed in swing-out trays (refer to Figure 9.5) on each side of the chassis.

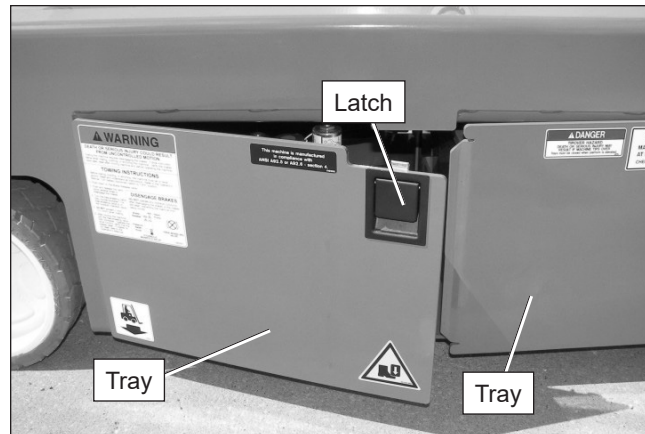

Figure 9.5 – Swing-Out Trays

- The battery trays each contain two batteries. There is a battery tray at the front of the machine, both sides of the chassis.
- The control valve tray on the right side of the chassis contains the hydraulic control valve with the free-wheeling valve, brake release valve and the brake hand pump. The diagnostic center LCD display is also in this tray.
- The hydraulic tray on the left side of the chassis contains the hydraulic pump, reservoir and fluid filter.

▲ Danger

The aerial platform can tip over if it becomes unstable. Death or serious injury will result from a tip-over accident. Do not open the trays when the platform is raised more than 8' (2.4 m).

- To open a tray, pull upward on the latch and swing the tray open.
- The latched tray must be opened first, before the battery tray can be opened.
- When closing the trays, close the battery tray first. The latched tray holds both trays in the closed position.

Electrical Power Outlet

The electrical power outlet has two, 3-prong, 125 volt AC electrical connectors (refer to Figure 9.6).



Figure 9.6 – Electrical Power Outlet

Power is supplied to the outlet by connecting an external power source to the power-input connector at the rear of the chassis (refer to Figure 9.7).

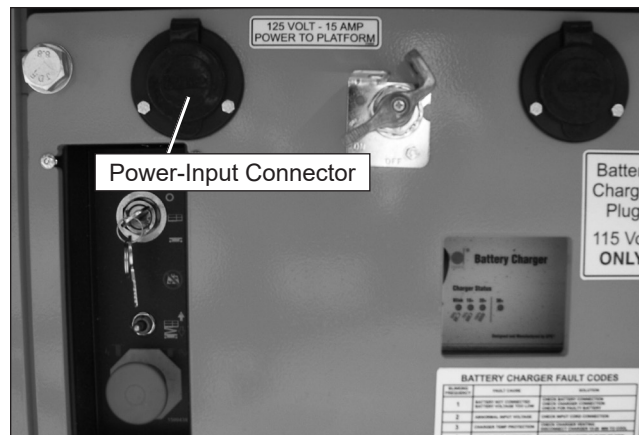

Figure 9.7 – Rear of Chassis

To use the outlet, plug a source of power into the power-input connector. Unplug the source of power before moving the aerial platform.

Pipe Rack – Top Rail Mount

Some machines may be equipped with an optional pipe rack mounted to the top rail on the left side of the machine.

The pipe rack is available on the following models:

- S3215E
- S3219E
- S4726E
- S4732E

The pipe rack consists of a pair of supports, one at the front and one at the rear of the platform (refer to Figure 9.8).

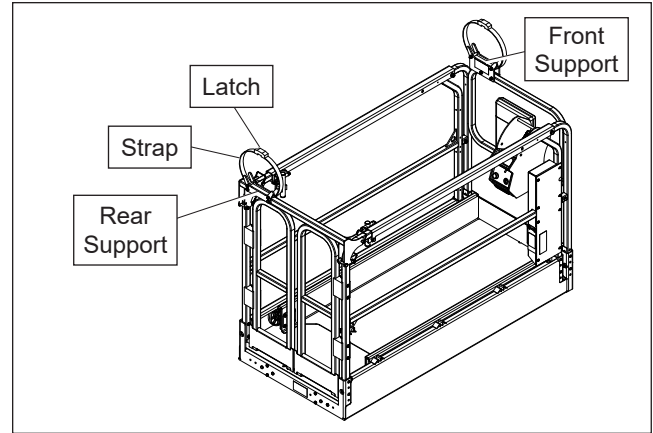

Figure 9.8 – Pipe Rack Top Rail Mount

▲ Danger

The aerial platform can tip over if it becomes unstable. Death or serious injury will result from a tipover accident. Do not exceed the capacity values indicated on the platform rating placard and on the pipe rack decal.

The rated load per pair of supports and the platform total capacity including the load on the pipe rack are stated in the pipe rack decal chart and in Figure 9.9.

Model	Rated Load per Pair of Supports	Platform Rated Work Load Including Pipe Rack Load
S3215E	50 lbs (22 kg)	600 lbs (272 kg)
S3219E	50 lbs (22 kg)	550 lbs (249 kg)
S4726E	400 lbs (181 kg)	1000 lbs (454 kg)
S4732E	150 lbs (68 kg)	700 lbs (317 kg)

Figure 9.9 – Pipe Rack Rated Load and Platform Capacity

A pipe rack decal is located on the front support and at the rear of the platform on the toeboard.

The platform rated work load is the total weight of the personnel and equipment that may be lifted in the platform.

Capacity values indicate the rated lifting capacity and do not indicate aerial platform stability.

The load carried in the pipe rack reduces the platform capacity by the weight of the load being carried.

▲ Danger

The aerial platform can tip over if it becomes unstable. Death or serious injury will result from a tipover accident. Do not exceed the stated pipe length requirements, use with any other platform option, or use outdoors.

The pipe rack is not to be used with any other platform option.

The pipe rack is for indoor use only with zero wind speed.

When loading the pipe rack:

- S3215E and S3219E machines – pipe length cannot exceed 10 feet (3.0m).
- S4726E and S4732E machines – pipe length cannot exceed 16 feet (4.8m).
- Pipes must be centered and overhangs must be equal.

The operator bears ultimate responsibility for ensuring that the aerial platform is properly set up for the particular condition encountered.

Use the following procedure to load the pipe rack.

1. Make certain no one is beneath the platform when operating the machine with the pipe racks loaded.
2. At the front and rear, press on the latch lever to release the latch and unfasten the straps.
3. Place the load evenly on the front and rear plates. Do not exceed the rated load on the pipe rack per pair of supports (refer to Figure 9.9).
4. Feed the straps through the latch and pull on the straps to secure the load.
5. Secure the load in the racks before operating the machine raise, lower, or drive functions.

Pipe Rack – Guardrail Mount S3219E Only

Some ANSI S3219E machines may be equipped with an optional pipe rack mounted inside the platform on the left side guardrails.

Note

This pipe rack option is compatible with ANSI S3219E machines with 39" (0.99m) guardrail height only.

The pipe rack (refer to Figure 9.10) is hooked over the top and mid rails and secured in position with fasteners.

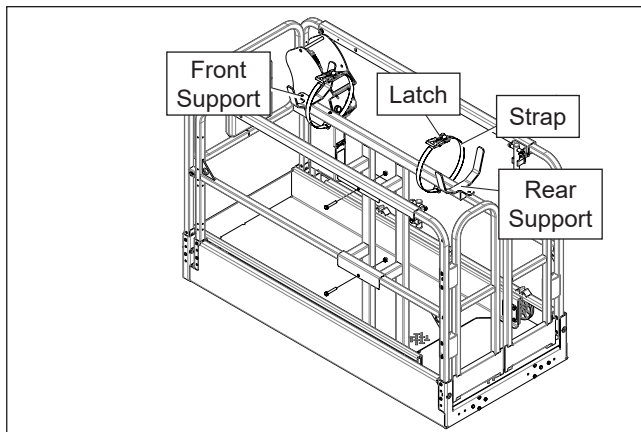

Figure 9.10 – Pipe Rack Guardrail Mount

⚠ Danger

The aerial platform can tip over if it becomes unstable. Death or serious injury will result from a tipover accident. Do not exceed the capacity values indicated on the platform rating placard and on the pipe rack decal.

The rated load and the platform total capacity including the load on the pipe rack are stated in the pipe rack decal chart and in Figure 9.11.

Model	Pipe Rack Rated Load	Platform Rated Work Load Including Pipe Rack Load
S3219E	130 lbs (59 kg)	550 lbs (249 kg)

Figure 9.11 – Pipe Rack Rated Load and Platform Capacity

A pipe rack decal is located on the front of the pipe rack on the inside of the platform.

The platform rated work load is the total weight of the personnel and equipment that may be lifted in the platform.

Capacity values indicate the rated lifting capacity and do not indicate aerial platform stability.

The load carried in the pipe rack reduces the platform capacity by the weight of the load being carried.

⚠ Danger

The aerial platform can tip over if it becomes unstable. Death or serious injury will result from a tipover accident. Do not exceed the stated pipe length requirements, use with any other platform option, or use outdoors.

The pipe rack is not to be used with any other platform option.

The pipe rack is for indoor use only with zero wind speed.

When loading the pipe rack:

- The height of the load in the rack cannot exceed 6 inches (150 mm).
- Pipe length cannot exceed 10' (3.0m).
- Pipes must be centered and overhangs must be equal.

The operator bears ultimate responsibility for ensuring that the aerial platform is properly set up for the particular condition encountered.

Use the following procedure to load the pipe rack.

1. Make certain no one is beneath the platform when operating the machine with the pipe racks loaded.

2. At the front and rear, press on the latch lever to release the latch and unfasten the straps.
3. Place the load evenly on the front and rear plates. Do not exceed the rated load on the pipe rack (refer to Figure 9.11).
4. Feed the straps through the latch and pull on the straps to secure the load.
5. Secure the load in the racks before operating the machine raise, lower, or drive functions.

Panel Carrier

Some machines may be equipped with an optional panel carrier mounted to the right side of the platform.

The panel carrier is available on the following models:

- S3215L
- S3215E
- S3219E
- S3220E
- S4726E
- S4732E

The panel carrier consists of a tray mounted at the bottom of the platform and a hook to slide down over the top of a panel that is placed in the tray.

The platform rated work load is the total weight of the personnel and equipment that may be lifted in the platform. The work load is stated on the platform rating placard mounted on the toeboard at the front of the platform and on the panel carrier decal.

⚠ Danger

The aerial platform can tip over if it becomes unstable. Death or serious injury will result from a tipover accident. Do not exceed the capacity values indicated on the platform rating placard and on the panel carrier decal.

Capacity values indicate the rated lifting capacity and do not indicate aerial platform stability.

The operator bears ultimate responsibility for ensuring that the aerial platform is properly set up for the particular condition encountered.

The load carried in the panel carrier reduces the platform capacity and is shown on the panel carrier decal.

Use the following procedure to load the panel carrier.

1. Place the panel load evenly on the tray.
2. Raise the hook and push the panel against the platform guardrails.

3. Lower the hook so it rests on top of the panel, securing it in place.
4. Do not exceed the platform total rated work load or the panel carrier rated work load (refer to Figure 9.12).

1503299 REV A			Electric Scissor Lifts	
Use Only on Listed Models	S3215L	S3220E	S3215E	S4726E
	S3219E	S4732E		
Part Number	1503205	1503206		
Rated Work Load on Panel Carrier	100 lb (45 kg)			
Total Rated Work Load, Including Load on Panel Carrier	300 lbs. (136kg)	400 lbs. (227kg)	1 Person	1 Person
Maximum Wind Speed	0 MPH			

Figure 9.12 – Panel Carrier Rated Load and Platform Capacity

Snorkel Guard

The optional Snorkel Guard (refer to Figure 9.13) is a mechanically activated guarding system which offers an additional level of protection to the operator at the upper controls.

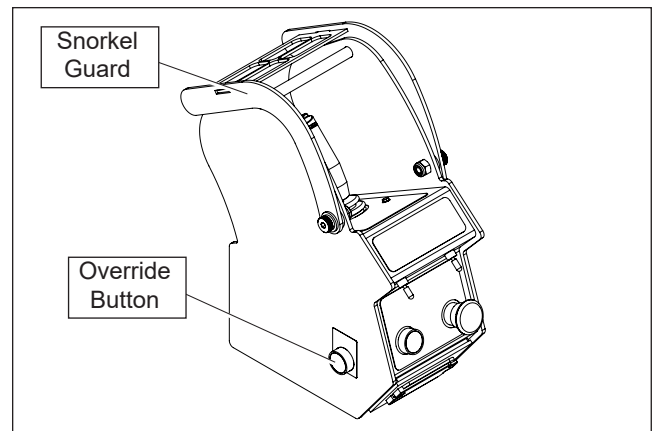

Figure 9.13 – Upper Controls

If an operator is involuntarily pushed against the spring-loaded Snorkel Guard rail that is mounted above the upper control panel, the machine functions are disabled.

When the Snorkel Guard is activated:

- the horn sounds.
- the blue light under the upper control panel flashes.
- only the platform lower function will operate.

The lower controls are not affected by the Snorkel Guard activation.

Override Button

The override button at the upper controls may be used to override the platform overload and the Snorkel Guard system, when either one is activated.

When the platform overload system is activated, the override or the emergency power button (refer to Figure 9.10) at the upper controls may be used to override the system to operate platform raise/lower functions.

When the Snorkel Guard system is activated, the override button (refer to Figure 9.13) at the upper controls may be used to override the system to operate platform raise/lower functions.

Warning

The potential for an accident increases when safety devices do not function properly. Death or serious injury could result from such accidents. The override switch must only be used when all controls are released and in the neutral position. If a zero or neutral state cannot be achieved, depress the emergency stop and obtain assistance at the lower controls.

1. When the machine is stopped due to activation of the Snorkel Guard system or overload, immediately depress the emergency stop, release the joystick interlock and all controls. Perform an assessment of the situation which caused the system to activate.
2. If it is determined that all controls are released and operation can proceed, return the emergency stop to the on position, and activate the override switch.
3. Activate the joystick interlock.
4. Activate the necessary functions to move the platform away from the obstacle that caused the Snorkel Guard activation or if due to an overload fault, lower the platform in a safe condition.
5. Assess the machine for any damage. If damage occurred, return to the stowed position, exit the unit and perform a thorough inspection before returning to service.

Snorkel OnSite

Snorkel OnSite is powered by Trackunit telematics. OnSite provides real-time access to machine information such as machine status (on/off), hours, location, and battery level. This data can help identify usage and maintenance trends to maximize operator efficiency. An optional keypad may be used to limit access to only authorized personnel by PIN code or RFID card.

For more information, please refer to the Trackunit information provided with the machine. For Trackunit Technical Support email supportus@trackunit.com or phone 1-844-661-0340. When contacting Trackunit Technical Support, have the Trackunit serial number, (7 digits starting with 3) available to aid in troubleshooting. The serial number can be found on the fleet list or under Fleet/Unit Page/Telematics tab.

Perimeter Lights

The optional perimeter lights provide a visual warning for pedestrians near the machine. A blue LED light mounted on the front and rear of the chassis projects a blue warning dot on the ground. The red LED lights on each side project a red boundary line on the ground.

The lights may be adjusted to increase or decrease the location of the blue dots and red lines next to the machine.

The perimeter lights are operational when the interlock switch on the upper controls or the interlock button on the loading controls is engaged.

After Use Each Day

1. Ensure that the platform is fully lowered.
2. Park the machine on a firm level surface, preferably under cover, secure against vandals, children and unauthorized operation.
3. Turn the controls selector switch to OFF and remove the key to prevent unauthorized operation.

Chapter 10 – Stowing and Transporting

To prevent unauthorized use and damage, properly stow the aerial platform at the end of each work day. It must also be properly stowed while transporting.

Stowing

Use the following procedure to properly stow the aerial platform.

⚠Caution

The extension deck is free to move when the extension deck lock(s) are disengaged. Personal injury may result from accidentally extending or retracting the deck. Make certain the extension lock(s) are fully engaged when the deck is extended in the working position and when it is stowed. Do not attempt to extend or retract the platform unless the aerial platform is on a level surface.

1. Fully retract the platform extension deck and ensure that it is secured in position, with the latch handles fully lowered and the lock(s) fully engaged.
2. Fully lower the platform.
3. Push the emergency stop button inward on the lower control panel.
4. Turn the battery disconnect switch off and lock it.
5. Securely close the swing-out trays.

Transporting

The aerial platform may be moved on a transport vehicle. Depending on the particular situation, the aerial platform may be lifted with a forklift, driven, winched, or hoisted onto a vehicle such as a truck or trailer. Lifting with a forklift is the preferred method.

The equipment used to load, unload, and transport the aerial platform must have adequate capacity. The empty vehicle weight is listed in Chapter 2 and is stamped on the serial number placard.

The user assumes all responsibility for:

- Choosing the proper method of transportation.
- Choosing the proper selection and use of transportation and tie-down devices.
- Making sure the equipment used is capable of supporting the weight of the aerial platform.
- Making sure all manufacturer's instructions and warnings, regulations and safety rules of their employer, the DOT, and/or any other state or federal law are followed.

Lifting With a Forklift

Use the following procedure to lift the aerial platform with a forklift.

1. Properly stow the aerial platform.
2. Remove all personnel, tools, materials, or other loose objects from the platform.
3. Insert the forklift forks into the pockets at the rear of the machine (refer to Figure 10.1).

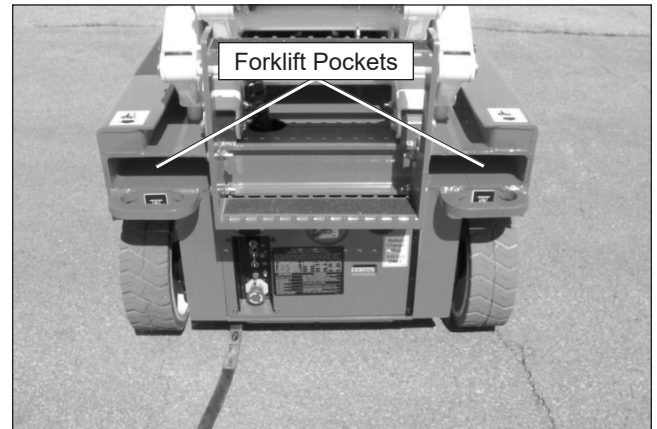

Figure 10.1 – Rear of Chassis

4. Do not raise the aerial platform higher than necessary to transport it. Drive the forklift slowly and carefully when transporting the aerial platform.

Winching

Use a winch to load and unload the aerial platform on ramps that exceed the machine gradeability specification. A winch may also be used when poor traction, uneven surfaces, or stepped ramp transition make driving hazardous.

Use the following procedure to winch the aerial platform onto the transport vehicle.

1. Position the transport vehicle so the aerial platform will not roll forward after it is loaded.
2. Remove any unnecessary tools, materials, or other loose objects from the platform.
3. Drive the machine to the foot of the loading ramp with the front wheels nearest the ramp. Make sure the machine is centered with the ramps and that the steering wheels are straight.
4. Properly stow the aerial platform.

⚠Warning

The aerial platform is free to move when the brakes are released. Death or serious injury could result. Re-enable the brakes before operating the aerial platform.

5. Chock the wheels to prevent uncontrolled motion of the aerial platform.

Valves with Brake Release Valve on Side of Valve

1. Unlatch and swing out the control valve tray on the right side of the machine. The brake release valve and free-wheeling valve are located on the side of the hydraulic manifold. The brake release pump is on the top of the valve (refer to Figure 10.2).

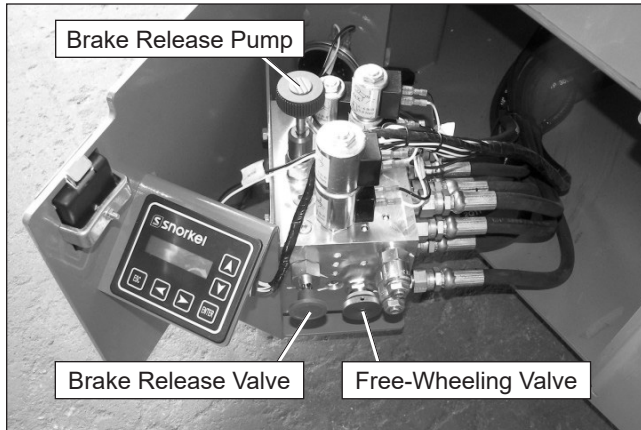

Figure 10.2 – Hydraulic Tray

2. Turn and depress the brake release valve to the fully open position.
3. Turn the free-wheeling valve counterclockwise to the fully open position.
4. Push and release the brake release pump knob until it can no longer be pumped.
5. Attach the winch line to the tie-down lugs (refer to Figure 10.3) on the front of the chassis.

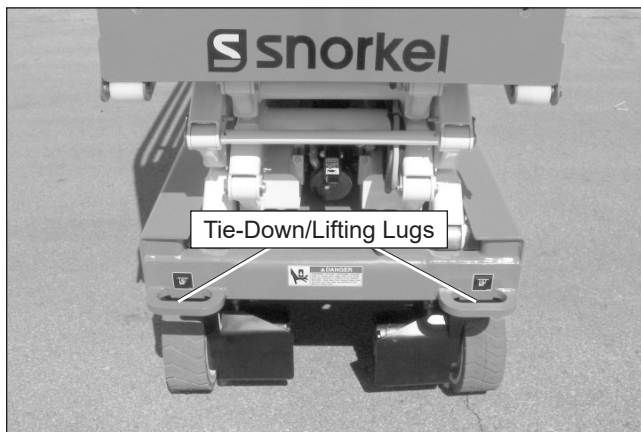

Figure 10.3 – Front of Chassis

6. Remove the wheel chocks and use the winch to position the aerial platform on the transport vehicle.

⚠Warning

The aerial platform is free to move when the brakes and free-wheeling valve are disabled. Death or serious injury could result. Close the free-wheeling valve and reset the brakes before operating the aerial platform.

7. Close the free-wheeling valve.
8. Drive the aerial platform forward or reverse and then stop to reset the parking brakes. The brake release valve can be heard when it resets, as the machine is driven.
9. Verify that the drive system and brakes operate properly before operating the aerial platform.

Valves with Brake Release Valve on Top of Valve

1. Unlatch and swing out the control valve tray on the right side of the machine. The brake release valve and brake release pump are located on the top of the hydraulic manifold. The free-wheeling valve is on the side of the valve (refer to Figure 10.4).

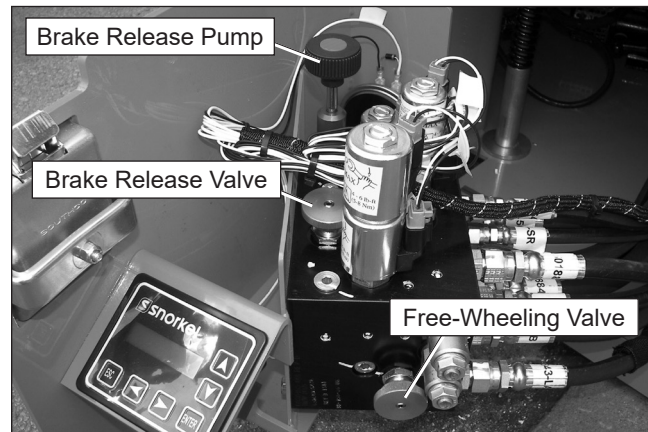

Figure 10.4 – Hydraulic Tray

2. Turn the brake release valve clockwise to the fully closed position. Turn the free-wheeling valve counterclockwise to the fully open position. Push and release the brake release pump knob several times, until it becomes hard to push, to release the brakes.
3. Attach the winch line to the tie-down lugs (refer to Figure 10.3) on the front of the chassis.
4. Remove the wheel chocks and use the winch to position the aerial platform on the transport vehicle.

⚠Warning

The aerial platform is free to move when the brakes and free-wheeling valve are disabled. Death or serious injury could result. Close the free-wheeling valve and reset the brakes before operating the aerial platform.

5. Turn the brake release valve counterclockwise to the fully open position. Turn the free-wheeling valve clockwise to the fully closed position.

6. Drive the aerial platform forward or reverse and then stop to reset the parking brakes.
7. Verify that the drive system and brakes operate properly before operating the aerial platform.

Valves with Brake Release/Free-Wheeling Valve on Back of Valve

1. Unlatch and swing out the control valve tray on the right side of the machine. The brake release/free-wheeling valve is located on the back of the hydraulic manifold (refer to Figure 10.5).

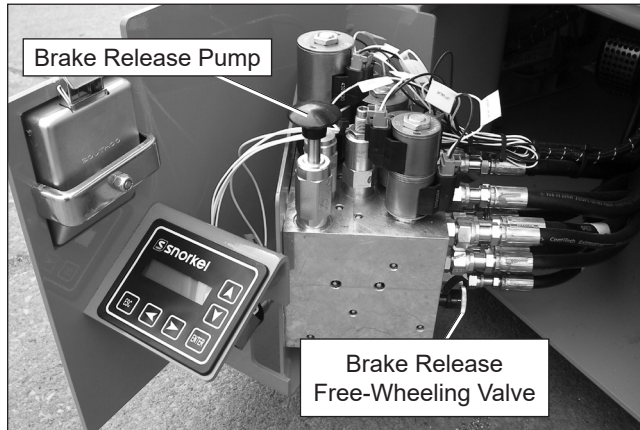

Figure 10.5 – Hydraulic Tray

2. Turn the brake release/free-wheeling valve clockwise to the fully closed position. Push and release the brake release pump knob several times, until it becomes hard to push, to release the brakes.
3. Attach the winch line to the tie-down lugs (refer to Figure 10.3) on the front of the chassis.
4. Remove the wheel chocks and use the winch to position the aerial platform on the transport vehicle.

⚠Warning

The aerial platform is free to move when the brakes and free-wheeling valve are disabled. Death or serious injury could result. Close the free-wheeling valve and reset the brakes before operating the aerial platform.

5. Turn the brake release/free-wheeling valve fully counterclockwise to the fully open position.
6. Drive the aerial platform forward or reverse and then stop to reset the parking brakes.
7. Verify that the drive system and brakes operate properly before operating the aerial platform.

Valves with Brake Release Pump and Brake Release/Free-Wheeling Valves on Top of Valve

1. Turn the battery disconnect switch to the off position.
2. Unlatch and swing out the control valve tray on the right side of the machine. The brake release pump and the brake release/free-wheeling valves are located on the top of the hydraulic manifold (refer to Figure 10.6).

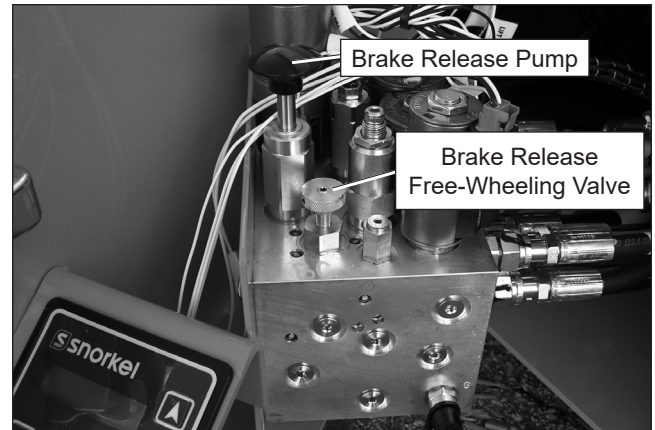

Figure 10.6 – Hydraulic Tray

3. Turn the brake release/free-wheeling valve clockwise to the fully closed position.
4. Push and release the brake release pump knob several times, until it becomes hard to push, to release the brakes.
5. Attach the winch line to the tie-down lugs (refer to Figure 10.3) on the front of the chassis.
6. Remove the wheel chocks and use the winch to position the aerial platform on the transport vehicle.

⚠Warning

The aerial platform is free to move when the brakes and free-wheeling valve are disabled. Death or serious injury could result. Close the free-wheeling valve and reset the brakes before operating the aerial platform.

7. Turn the brake release/free-wheeling valve counterclockwise to the fully open position.
8. Drive the aerial platform forward or reverse and then stop to reset the parking brakes.
9. Verify that the drive system and brakes operate properly before operating the aerial platform.

Driving

⚠ Danger

The aerial platform can tip over if it becomes unstable. Death or serious injury will result from a tip-over accident. Do not drive on ramps that exceed the machine gradeability specification, or where conditions of the ramp could cause driving to be hazardous.

Use a winch to load and unload the aerial platform on ramps that exceed the machine gradeability specification. A winch may also be used when poor traction, uneven surfaces, or stepped ramp transitions make driving hazardous.

Drive the aerial platform onto the transport vehicle if a winch is not available and the ramp incline is within the 25 percent grade capability of the aerial platform.

Use the following procedure to drive the aerial platform onto the transport vehicle.

1. Position the transport vehicle so the aerial platform will not roll forward after it is loaded.
2. Chock the vehicle wheels so it cannot roll away from the ramp while the aerial platform is loaded.
3. Remove any unnecessary tools, materials, or other loose objects from the platform.

⚠ Caution

The extension deck is free to move when the extension deck lock(s) are disengaged. Personal injury may result from accidentally extending or retracting the deck. Make certain the extension lock(s) are fully engaged when the deck is extended in the working position and when it is stowed. Do not attempt to extend or retract the platform unless the aerial platform is on a level surface.

4. Fully retract the platform extension deck and ensure that it is secured in position, with the latch handles fully lowered and the lock(s) fully engaged. Fully lower the platform.
5. Drive the aerial platform to the foot of the loading ramp with the rear wheels nearest the ramp. Make sure the aerial platform is centered with the ramps and that the steering wheels are straight.
6. Place the drive range switch in low (turtle) for climbing or descending a ramp.
7. Drive the aerial platform on or off the transport vehicle in a straight line through the grade transitions with minimal turning.

The machine may be equipped with a loading control station beneath the upper control box on the platform guardrail. Drive functions may be operated from this

location when loading the machine. The loading controls may be a fixed side drive or a corded pendant (refer to Figure 10.7).

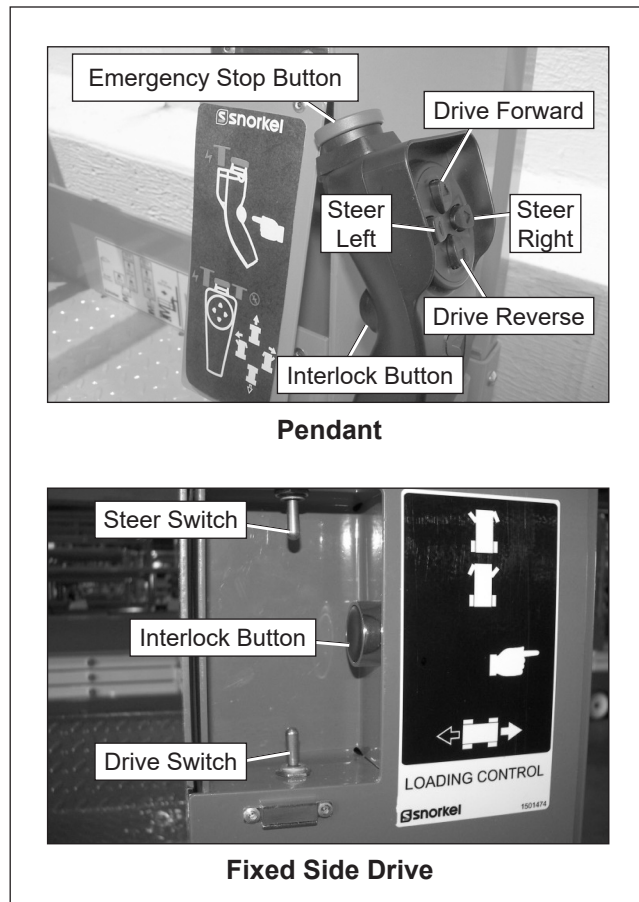

Figure 10.7 – Loading Controls

⚠ Danger

Pinch points may exist between moving components. Death or serious injury will result from becoming trapped between components, buildings, structures, or other obstacles. Make sure there is sufficient clearance around the machine before moving the chassis. Allow sufficient room and time to stop movement to avoid contact with structures or other hazards.

Maintain at least 3' (1 m) between yourself and the aerial platform when operating either the removable upper controls or the loading controls from the ground outside of the platform.

The loading controls allow for driving the machine while standing on the ground, outside of the platform. Always look in the direction of movement when operating the loading controls.

Use the following procedure to operate the drive and steer functions from the loading controls.

1. From the upper controls, pull the emergency stop button outward.

2. Raise the door on the right side of the platform to access the loading controls (refer to Figure 10.6).
3. Push and release the interlock button.

Note

You have five seconds to activate a drive or steer control after pressing the interlock button. After five seconds, the interlock button will have to be pressed again.

4. The drive switches (refer to Figure 10.6) are momentary contact. These switches control the two front wheels to drive the aerial platform.
 - On the pendant – engage the interlock button and hold down either the drive forward or drive reverse button.
 - On the fixed sided drive – to drive forward, press the interlock button inward and hold the switch forward. To drive in reverse, press the interlock button and hold the switch rearward.

Note

To make an emergency stop push the emergency stop button inward to apply the parking brakes.

5. The steer switches (refer to Figure 10.6) are momentary contact. These switches control the two front wheels to steer the aerial platform.
 - On the pendant – press the interlock button and hold down either the steer left or steer right button.
 - On the fixed side drive – press the interlock button and hold the switch in the appropriate direction to steer either left or right.

Note

Holding the steer switch too long may result in a sharp turn. This is especially true when driving and steering at the same time. It may be easier to turn the wheels in small increments using a series of quick taps on the switch.

6. Set the steer wheels straight ahead after completing a turn. The steering wheels are not self-centering.

Hoisting

Use a four point sling arrangement attached to the lifting lugs when hoisting the aerial platform. Machine damage can occur if the sling is attached anywhere else.

⚠Warning

The potential for an accident increases when the aerial platform is lifted using improper equipment and/or lifting techniques. Death or serious injury could result from such accidents. Use proper equipment and lifting techniques when lifting the aerial platform.

Know the weight of the aerial platform and the capacity of the lifting devices before hoisting.

- Lifting devices include the hoist or crane, chains, straps, cables, hooks, sheaves, shackles, slings, and other hardware used to support the machine.
- The empty vehicle weight is stamped on the serial number placard and is listed in Chapter 2.

The user assumes all responsibility for:

- Making sure the equipment used is capable of supporting the weight of the aerial platform.
- Making sure all manufacturer’s instructions and warnings, regulations and safety rules of their employer and/or any state or federal law are followed.

Use the following procedure to hoist the aerial platform onto the transport vehicle:

1. Properly stow the aerial platform.
2. Inspect the front lifting lugs and the rear lifting lugs (refer to Figures 10.3 and 10.8) to make sure they are free of cracks and are in good condition. There are two lugs on the rear of the chassis and two on the front. Have any damage repaired by a qualified service technician before attempting to hoist the machine.

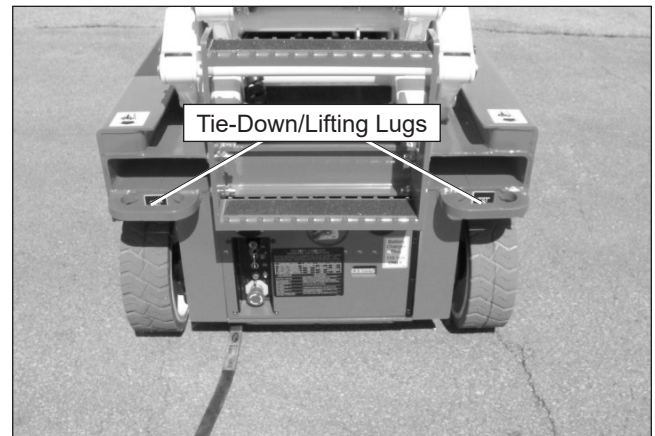

Figure 10.8 – Rear of Chassis

3. Remove all personnel, tools, materials, or other loose objects from the platform.
4. Connect the chains or straps to the lifting lugs using bolted shackles. Hooks that fit properly in the lugs and that have latching mechanisms to prevent them from falling out under a slack line condition may also be used.

Do not run the sling cable through the lifting lugs.

- Cable damage and/or failure can result from the cable contacting the sharp corners of the lug.

- There is no effective way of putting a corner protector in the hole of the lug.
5. Use spreader bars of sufficient length to keep the chains, straps, or cables from contacting the scissors structure or platform.
 - When using cables, use rigid corner protectors at any point where the cable contacts on sharp corners to prevent damaging the cable.
 - Careful rigging of the spreaders is required to prevent machine damage.
 6. Adjust the length of each chain or strap so the aerial platform remains level when raised off the ground.
 7. Use the hoist or crane to carefully raise and position the aerial platform onto the transport vehicle.

Securing for Transport

Use the following procedure to secure the aerial platform on the transport vehicle.

1. Chock the wheels.
2. Remove all personnel, tools, materials, or other loose objects from the platform.
3. Properly stow the aerial platform.

4. Place wood blocks under the front ends of the pothole protection skids to limit excessive loading on the front drive wheel bearings.
5. Place the lower controls emergency stop switch in the off position.
6. Turn the battery disconnect switch off.

Caution

Ratchets, winches, and come-alongs may produce enough force to damage machine components. Do not over tighten the straps or chains when securing the aerial platform to the transport vehicle.

7. Use chains or straps to securely fasten the aerial platform to the transport vehicle using the front and rear tie-down lugs as attachment points. Proper tie-down and hauling is the responsibility of the carrier.

Storage

No service is required when storing, or removing the machine from service, for less than one week.

If the machine functions are not cycled for longer than one week:

- Grease exposed cylinder rods with a light, white lithium grease.
- Periodically charge the batteries.

Chapter 11 – Emergency Operation

If the main hydraulic system fails:

- The aerial platform may be lowered using the emergency lowering lever.
- The machine may be towed if the drive system fails.
- Refer to Emergency Lowering, or Towing for the appropriate procedure.

Emergency Lowering

Use the following procedure to operate the emergency lowering system.

Warning

The potential for an accident increases when safety devices do not function properly. Death or serious injury could result from such accidents. Immediately push the emergency stop button inward to disable the control system before using the emergency lowering system in the event of an emergency.

1. Immediately push the emergency stop button inward to disable the control system in the event of an emergency.
2. Retract the platform extension, if possible.
3. Locate the emergency lowering control.

The lever for the S3215L/S3215E/S3219E is mounted at the front of the aerial platform (refer to Figure 11.1).

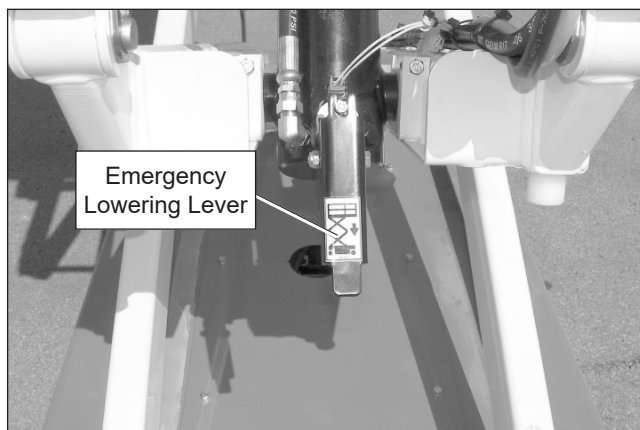

Figure 11.1 – Front of Machine

The handle for the S3220E/S3226E/S4726E/S4732E is mounted at the rear of the aerial platform (refer to Figure 11.2).

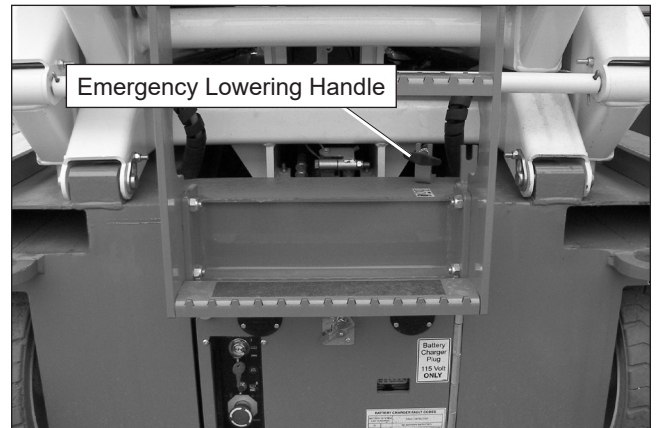

Figure 11.2 – Rear of Machine

Danger

Pinch points may exist between moving components. Death or serious injury will result from becoming trapped between components. Make sure all personnel stand clear while lowering the platform with the emergency lowering system.

4. Make sure there is nothing in the way to obstruct the platform when it lowers.
5. Stand clear of the scissors structure.
 - S3215L/S3215E/S3219E – push downward on the emergency lowering lever at the front of the machine to lower the platform.
 - S3220E/S3226E/S4726E/S4732E – pull outward on the emergency lowering handle at the rear of the machine to lower the platform.
6. The platform will begin to lower as the lever/handle is actuated. Release the lever/handle to stop the platform from lowering.

Warning

The potential for an accident increases when safety devices do not function properly. Death or serious injury could result from such accidents. Fully close the emergency lowering valve before operating the aerial platform.

7. Make certain the lever is fully released and the emergency lowering valve is fully closed before operating the aerial platform.

Towing

The aerial platform may be pushed or pulled after properly stow the aerial platform and disengaging the brakes. Use the following procedure to manually disengage the brakes.

Valves with Brake Release Valve on Side of Valve

1. Chock the wheels to prevent uncontrolled motion of the aerial platform and turn the battery disconnect switch off.
2. Unlatch and swing out the control valve tray on the right side of the machine. The brake release valve and free-wheeling valve are located on the side of the hydraulic manifold. The brake release pump is on the top of the valve (refer to Figure 11.3).

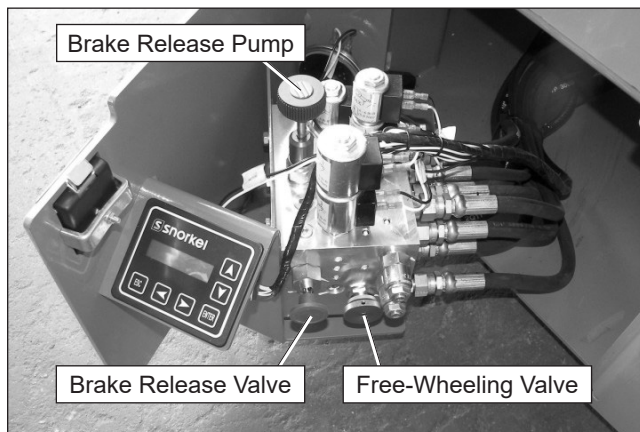

Figure 11.3 – Hydraulic Tray

3. Turn and depress the brake release valve to the fully open position.
4. Turn the free-wheeling valve counterclockwise to the fully open position.
5. Push and release the brake release pump knob until it can no longer be pumped.
6. Remove the wheel chocks.
7. Do not exceed 2 mph (3.2 km/h) when towing.

⚠Warning

The aerial platform is free to move when the brakes and free-wheeling valve are disabled. Death or serious injury could result. Close the free-wheeling valve and reset the brakes before operating the aerial platform.

8. Close the free-wheeling valve.
9. Drive the aerial platform forward or reverse and then stop to reset the parking brakes. The brake release valve can be heard when it resets, as the machine is driven.
10. Verify that the drive system and brakes operate properly before operating the aerial platform.

Valves with Brake Release Valve on Top of Valve

1. Chock the wheels to prevent uncontrolled motion of the aerial platform and turn the battery disconnect switch off.
2. Unlatch and swing out the control valve tray on the right side of the machine. The brake release valve and brake release pump are located on the top of the hydraulic manifold. The free-wheeling valve is on the side of the valve (refer to Figure 11.4).

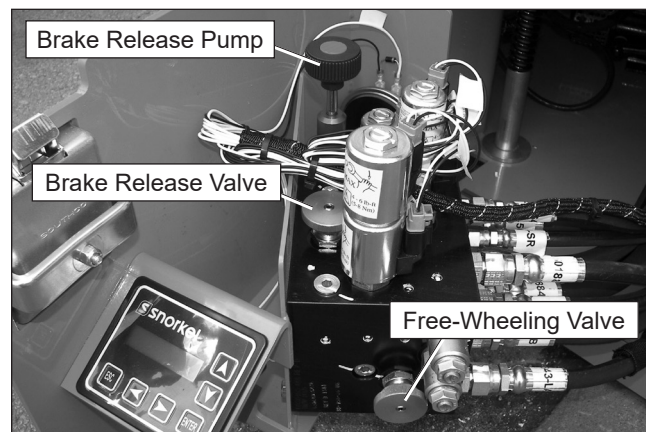

Figure 11.4 – Hydraulic Tray

3. Turn the brake release valve clockwise to the fully closed position. Turn the free-wheeling valve counterclockwise to the fully open position. Push and release the brake release pump knob several times, until it becomes hard to push, to release the brakes.
4. Remove the wheel chocks.
5. Do not exceed 2 mph (3.2 km/h) when towing.

⚠Warning

The aerial platform is free to move when the brakes and free-wheeling valve are disabled. Death or serious injury could result. Close the free-wheeling valve and reset the brakes before operating the aerial platform.

6. Turn the brake release valve counterclockwise to the fully open position. Turn the free-wheeling valve clockwise to the fully closed position.
7. Drive the aerial platform forward or reverse and then stop to reset the parking brakes.
8. Verify that the drive system and brakes operate properly before operating the aerial platform.

Valves with Brake Release/Free-Wheeling Valve on Back of Valve

1. Chock the wheels to prevent uncontrolled motion of the aerial platform and turn the battery disconnect switch off.
2. Unlatch and swing out the control valve tray on the right side of the machine. The brake release/free-wheeling valve is located on the back of the hydraulic manifold (refer to Figure 11.5).

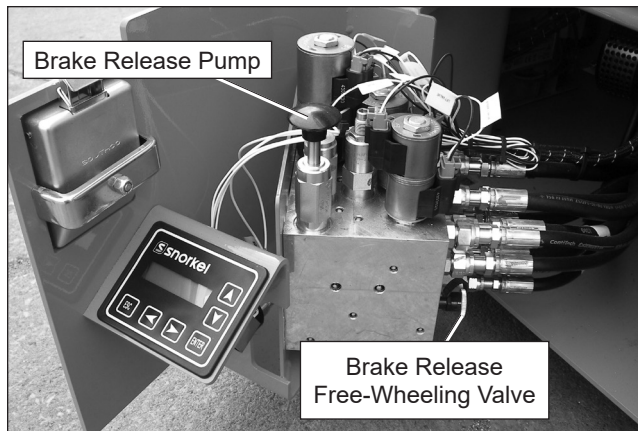

Figure 11.5 – Hydraulic Tray

3. Turn the brake release/free-wheeling valve clockwise to the fully closed position. Push and release the brake release pump knob several times, until it becomes hard to push, to release the brakes.
4. Remove the wheel chocks.
5. Do not exceed 2 mph (3.2 km/h) when towing.

Warning

The aerial platform is free to move when the brakes and free-wheeling valve are disabled. Death or serious injury could result. Close the free-wheeling valve and reset the brakes before operating the aerial platform.

6. Turn the brake release/free-wheeling valve fully counterclockwise to the fully open position.
7. Drive the aerial platform forward or reverse and then stop to reset the parking brakes.
8. Verify that the drive system and brakes operate properly before operating the aerial platform.

Valves with Brake Release Pump and Brake Release/Free-Wheeling Valves on Top of Valve

1. Turn the battery disconnect switch to the off position.
2. Unlatch and swing out the control valve tray on the right side of the machine. The brake release pump and the brake release/free-wheeling valves are located on the top of the hydraulic manifold (refer to Figure 11.6).



Figure 11.6 – Hydraulic Tray

3. Turn the brake release/free-wheeling valve clockwise to the fully closed position.
4. Push and release the brake release pump knob several times, until it becomes hard to push, to release the brakes.
5. Remove the wheel chocks.
6. Do not exceed 2 mph (3.2 km/h) when towing.

Warning

The aerial platform is free to move when the brakes and free-wheeling valve are disabled. Death or serious injury could result. Close the free-wheeling valve and reset the brakes before operating the aerial platform.

7. Turn the brake release/free-wheeling valve counterclockwise to the fully open position.
8. Drive the aerial platform forward or reverse and then stop to reset the parking brakes.
9. Verify that the drive system and brakes operate properly before operating the aerial platform.

Chapter 12 – Troubleshooting

The troubleshooting chart may be used to locate and eliminate situations where machine operation may be interrupted. If the problem cannot be corrected with the

action listed, stow the machine and remove it from service. Repairs must be made by qualified maintenance personnel.

Troubleshooting Chart

Symptom	Possible Cause	Corrective Action
All functions stop working.	Motor or pump failure.	Manually stow the machine using the emergency lowering lever.
	Low fluid level in reservoir.	Check hydraulic fluid level. Add correct type of fluid if necessary.
	Batteries discharged.	Recharge batteries.
	Electrical system malfunction.	Stow the machine and do not operate until repairs are made.
Platform will not raise or lower from lower controls.	Control select/ground operation switch is in the upper control or the off position.	Place the switch in the lower control position.
	Battery disconnect is turned off.	Place the switch in the on position.
	Emergency stop button is pushed inward to the off position.	Pull the emergency stop button outward to the on position.
	Emergency lowering lever is not properly disengaged.	Make sure the lever returns to the normal operating position.
Platform will not raise or lower from upper controls.	Drive/lift selector is in the drive position.	Place switch in the lift position.
	Emergency lowering lever not properly disengaged.	Make sure the lever returns to the normal operating position.
Platform will not raise and alarm is sounding.	Machine is not on a level surface.	Lower the platform and drive to a level surface.
Platform will not raise, or raises slower than normal.	Emergency lowering lever not properly disengaged.	Make sure the lever returns to the normal operating position.
	Platform capacity has been exceeded.	Remove load from platform. Refer to platform capacity placard for maximum capacity.
	Low battery charge.	Check the battery charge indicator and recharge the batteries if necessary.
Platform drifts down.	Emergency lowering lever not properly disengaged.	Make sure the lever returns to the normal operating position.
	Hydraulic system malfunction.	Stow the machine and do not operate until repairs are made.
Platform will not lower.	Safety prop in place.	Stow the safety prop.
Platform will not extend.	Deck lock(s) are not fully engaged.	Fully disengaged the lock(s), before extending the platform.
Drive functions don't work.	Drive/lift selector is in the lift position.	Place the switch in the drive position.
	Machine is not on a level surface or too steep a grade.	Lower the platform and drive to a level surface.
	Free-wheeling valve is open.	Fully close the free-wheeling valve.
	Load capacity exceeded.	Remove load from platform. Refer to platform capacity placard for maximum capacity.
	Low hydraulic system pressure.	Stow the machine and do not operate until repairs are made.

Symptom	Possible Cause	Corrective Action
Drive functions don't work, continued.	Pothole interlock engaged.	Clear obstruction.
Machine will not climb a 25 percent grade – S3226E/S4726E/S4732E.	Drive range selector is not in the low position.	Place the switch in the low (turtle) position.
Only slow drive speed works.	Platform elevated above 7 to 8 feet (2.1 to 2.4 m).	Normal operation, lower platform to drive machine at faster speed.
	Drive range selector is in the low (turtle) position – S3226E/S4726E/S4732E.	Place the switch in the high (rabbit) position.
Machine will not steer.	Joystick interlock switch not engaged.	Engage the interlock switch before operating the steer switch.
Wheels won't turn when winching or pushing.	Brakes are engaged.	Manually release the brakes using the hand pump. Refer to Towing, Chapter 11.
	Free-wheeling valve not in proper position.	Refer to Winching, Chapter 10.
Tilt alarm does not work.	Platform is not raised more than 6' (1.8 m).	Normal operation. The tilt alarm is not active until the platform is raised more than 6' (1.8 m).
Battery charger does not indicate a reading when charging batteries.	No source of power.	Make sure power source is plugged in and turned on.
	Faulty batteries or charger.	Stow the machine and do not operate until repairs are made.
Hydraulic fluid temperature of 160°F (71°C) or more.	Prolonged driving or platform operation.	Stop operation until fluid cools.
	High pressure fluid return to reservoir caused by kinked or twisted hose.	Remove the kink or twist from the hose. Let fluid cool before resuming operation.
	Hydraulic system component failure.	Stow the machine and do not operate until repairs are made.
Severe hydraulic leak.	Failure of hose, tube, fitting, seal, etc.	Stow the machine and do not operate until repairs are made.

Appendix A – Glossary

aerial platform – a mobile device that has an adjustable position platform, supported from ground level by a structure.

ambient temperature – the air temperature of the immediate environment.

authorized personnel – personnel approved as assigned to perform specific duties at a specific location.

base – the relevant contact points of the aerial platform that form the stability support (e.g. wheels, casters, stabilizers).

battery tray – a swing-out compartment that holds all, or some, of the machine batteries.

center of gravity – the point in the aerial platform around which its weight is evenly balanced.

chassis – the integral part of the aerial platform that provides mobility and support for the scissors structure.

control valve tray – a swing-out compartment that holds the control valve, freewheeling valve, hand pump, and the diagnostic display.

fall protection – a system to protect against falls that may include either a fall restraint or personal fall arrest system as required by national or local regulations and standards.

fall restraint – a system that is used while working on a boom lift within the boundaries of platform guardrails to provide restraint from being projected upward from the platform. This system includes a harness or belt, lanyard, and a lanyard anchor. Although federal regulations, OSHA, ANSI, and Snorkel do not require the use of additional fall protection beyond the platform guardrails on scissor lift aerial platforms, local, state, or employer rules may require their use.

floor or ground pressure – the maximum pressure, expressed in pounds per square inch, a single wheel concentrates on the floor or ground.

free-wheeling valve – a needle valve that, when adjusted open, allows hydraulic fluid to flow through the wheel drive motors. This allows the aerial platform to be pushed or towed without damage to the drive motors.

gradeability – the maximum slope that the aerial platform is capable of travel.

ground fault circuit interrupter (GFCI) – a fast-acting circuit breaker that opens to stop electrical circuit flow if it senses a very small current leakage to ground. The GFCI is used to protect personnel against a potential shock hazard from defective electrical tools or wiring.

guardrail system – a vertical barrier around the platform to prevent personnel from falling.

hazardous location – any location that contains, or has the potential to contain, an explosive or flammable atmosphere as defined by ANSI/NFPA 505.

hydraulic tray – a swing-out compartment that holds the hydraulic pump, fluid reservoir and the fluid filter.

level sensor – a device that detects a preset degree of variation from perfect level. The level sensor is used to sound an alarm if operating on a slope greater than the preset value.

lower controls – the controls located at ground level for operating some or all of the functions of the aerial platform.

manufacturer – a person or entity who makes, builds or produces an aerial platform.

maximum travel height – the maximum platform height or the most adverse configuration(s) with respect to stability in which travel is permitted by the manufacturer.

maximum wheel load – the load or weight that can be transmitted through a single wheel to the floor or ground.

MEWP – Mobile Elevating Work Platform.

Minimum Safe Approach Distance (M.S.A.D.) – the minimum safe distance that electrical conductors may be approached when using the aerial platform.

operation – the performance of any aerial platform functions within the scope of its specifications and in accordance with the manufacturer's instructions, the users work rules, and all applicable governmental regulations.

operator – a qualified person who controls the movement of an aerial platform.

personal fall arrest system – a fall protection system that is used while working on an unprotected edge (such as a roof top with no guardrail). This system includes a harness, lanyard or other connecting device, a fall arrestor, an energy absorber or decelerator, an anchorage connector, and a secure anchorage such as a building beam, girders or columns. An aerial platform is not a fall arrest anchorage.

platform – the portion of an aerial platform intended to be occupied by personnel with their tools and materials.

platform height – the vertical distance measured from the floor of the platform to the surface upon which the chassis is being supported.

pothole protection interlock – a safety feature that sounds an alarm and automatically stops the platform raise function if the pothole protection skids are prevented from lowering properly.

pothole protection system – a mechanical tip-over prevention system consisting of skids along the bottom of both sides of the chassis which lower as the platform is raised.

prestart inspection – a required safety inspection routine that is performed daily before operating the aerial platform.

qualified person – a person, who by reason of knowledge, experience, or training is familiar with the operation to be performed and the hazards involved.

rated work load – the designed carrying capacity of the aerial platform as specified by the manufacturer.

safety prop – a bar that when properly positioned mechanically prevents the platform from lowering.

stow – to place a component, such as the platform, in its rest position.

turning radius – the radius of the circle created by the wheel during a 360° turn with the steering wheels turned to maximum. Inside turning radius is the wheel closest to the center and outside turning radius is the wheel farthest from the center.

unrestricted rated work load – the maximum designed carrying capacity of the aerial platform allowed by the manufacturer in all operating configurations.

upper controls – the controls located on or beside the platform used for operating some or all of the functions of the aerial platform.

wheelbase – the distance from the center of the rear wheel to the center of the front wheel.

working envelope – the area defined by the horizontal and vertical limits of travel that the platform may be positioned in.

working height – platform height plus six feet (1.8 meters).

Appendix B – Declaration of Conformity

Appendix C – Inspection Checklists

Prestart Inspection Checklist

Item	Inspect For	P	F	R
Operator's Manual	In manual holder, all pages readable and intact			
Electrical System				
Battery fluid level	Proper level			
Battery terminals	Clean, connectors tight			
Battery charger	Proper operation			
Cables and wiring harness	No wear or physical damage			
Hydraulic System				
Fluid level	Visible in sight glass/on dipstick with platform stowed			
Hoses, tubes and fittings	No leaks, all fittings tight			
Free-wheeling valve	In normal operation position. Side mount CW/Back mount CCW			
Diagnostic Center Display	Displays operating time/battery power			
Tires and Wheels	Good condition			
Ground Strap	In place and securely fastened			
Lower Control Station				
Operating controls	Proper operation			
Emergency stop	Shuts off lower controls/proper operation			
Lowering alarm	Sounds when platform lowers			
Lowering interrupt – CE/AS/NZS	Sounds when platform lowers/proper operation			
Pothole Protection Interlock	Proper operation			
Emergency Lowering	Proper operation			
Safety Prop	No damage or deformation			
Flashing/Perimeter Light – option	Proper operation			
Pipe Rack – option	No damage or deformation. Proper operation			
Panel Carrier – option	No damage or deformation. Proper operation			
Snorkel Guard – option	No damage or deformation. Proper operation			
Bumpguard – option	No damage or deformation. Proper operation			
Airline to platform – option	No damage or deformation. Proper operation			
Inverter – option	No damage or deformation. Proper operation			
Structures				
Weldments – Chassis/platform/etc.	Welds intact, no damage or deformation			
Rollers and slide blocks	In place, no damage or deformation			
Fasteners	In place, tight, and no damage			
Upper Control Station				
Guardrail system	Welds intact, no damage or deformation All fasteners in place, no loose or missing parts			
Platform extension lock(s)/handles	Proper operation, no damage or deformation			
Brakes	Proper operation			
Operating controls	Proper operation			
Emergency stop	Shuts off upper controls			
Lowering alarm	Sounds when platform lowers			
Drive motion alarm	Sounds when aerial platform drive function is operated			
Battery condition indicator	Proper operation			
Horn	Sounds when activated			
Placards and Decals	In place and readable			

Maintenance Table Key: P = Pass, F = Fail, R = Repaired

Performed by: _____ Date: _____

Model: _____ Serial Number: _____

Frequent Inspection and Maintenance – Every 90 Days or 150 Hours

Item	Procedure	Information	P/F/R
Electrical System			
Batteries	Clean terminals, check electrolyte levels and cable connections	Add distilled water if necessary	
Cables and wiring harness	Check for wear and damage		
Battery charger	Check for proper operation	Ensure batteries are fully charged	
Hydraulic System			
Hydraulic fluid condition	Visually inspect a sample taken from the center of the reservoir. Do a lab test if necessary. Flush system and replace fluid as necessary.	Above 10°F (-12°C) ISO VG32 Below 10°F (-12°C) ISO VG15	
Fluid reservoir	Check for leaks		
Return filter	Replace after the first 50 hours, every 90 days or 150 hours thereafter Inspect filter for foreign matter that could indicate component wear		
Hoses, tubes, and fittings	Check for leaks, blistering, cracks, etc.		
Fluid level	Fill with proper fluid, visible in sight glass/on dipstick with platform stowed	See above	
Filler cap	Check for wear and securely fasten		
Free-wheeling valve	Fully closed		
Motor and pump assembly	Check for damage and leaks Check for proper operation		
Structures			
Weldments	Check for damage and cracked welds		
Slide pads/blocks	Check for wear and proper operation	Do not lubricate	
Fasteners	Verify that all fasteners are in place and are tight		
Scissor pins/king pins	Check for damage and cracked welds		
Wheels and Tires			
	Check for wear and damage Retorque castle nuts to 150 ft lb		
Steering Cylinder – Fasteners and Linkage			
	Check for cylinder damage and leaks Check for proper operation		
Scissor Structure			
Pivot pins, snap rings, bolts and nuts	Check for wear and damage, or missing components		
Lift cylinder and valves	Check for wear/damage/leakage and proper operation		
Emergency lowering valve	Check for proper operation		
Hoses, tubes, and fittings	Check for leaks, blistering, cracks, etc.		
Cables and wiring harness	Check for wear and damage		
Safety prop	Check for damage and deformation		
Parking Brakes			
	Check for leaks and proper operation		
Ground Strap			
	In place and securely fastened		
Pothole Protectors			
Interlock and alarm	Check for damage and proper operation		
Linkage/skid pivot points	Check for damage and proper operation		

Frequent Inspection and Maintenance – Every 90 Days or 150 Hours

Item	Procedure	Information	P/F/R												
Swing-out Trays															
Hinges and latches	Check for damage and proper operation														
Placards and Decals															
	Check for damage and readability														
	Order replacements as necessary	Refer to Parts Manual													
Operator's Manual															
	Proper manual in document holder														
Platform															
Guardrail system	Welds intact, no damage or deformation														
	All fasteners in place, no loose or missing parts														
Platform floor	Check for damage and deformation														
	Clean to prevent slip and fall hazards														
Platform extension	Check for damage and deformation														
	Smooth operation														
	Check for proper operation of lock(s) and handles														
Swing-down rails—if equipped	Verify that all fasteners are in place and that the rails fold down properly.														
Entry doors	Check for damage and deformation														
	Check for proper operation														
Lanyard anchors	Check for wear and damage														
Emergency Lowering System															
	Check for proper operation														
Lower Controls															
Operating controls	Check for smooth operation and proper speed	Refer to Operator's Manual for function speeds													
Emergency stop	Shuts off power to lower controls														
Lowering alarm—if equipped	Verify that alarm sounds while the platform is lowering														
Lowering interrupt – CE only	Verify that the platform stops lowering when it reaches about 1.8 m (6')														
Control selector switch	Check for proper operation	In the lower controls position, the upper controls should not be functional.													
Lift capacity	Check lift function at maximum load capacity	Maximum Load													
		<table style="width: 100%; border-collapse: collapse;"> <tr> <td style="width: 150px;">S3215L</td> <td>670 lb (305kg)</td> </tr> <tr> <td>S3215E</td> <td>600 lb (273 kg)</td> </tr> <tr> <td>S3219E</td> <td>550 lb (250 kg)</td> </tr> <tr> <td>S3220E</td> <td>900 lb (409 kg)</td> </tr> <tr> <td>S3226E</td> <td>500 lb (227 kg)</td> </tr> <tr> <td>S4726E</td> <td>1000 lb (455 kg)</td> </tr> <tr> <td>S4732E</td> <td>700 lb (318 kg)</td> </tr> </table>	S3215L	670 lb (305kg)	S3215E	600 lb (273 kg)	S3219E	550 lb (250 kg)	S3220E	900 lb (409 kg)	S3226E	500 lb (227 kg)	S4726E	1000 lb (455 kg)	S4732E
S3215L	670 lb (305kg)														
S3215E	600 lb (273 kg)														
S3219E	550 lb (250 kg)														
S3220E	900 lb (409 kg)														
S3226E	500 lb (227 kg)														
S4726E	1000 lb (455 kg)														
S4732E	700 lb (318 kg)														
	While the platform is loaded, raise the platform and with a pen, mark the chassis next to the slide pad. Mark on the side of the pad toward the front of the chassis. Wait for 15 minutes to determine if the lift cylinder is drifting. If the slide pad covers the mark, the cylinder or holding valve is leaking.	If the cylinder or holding valve leaks, remove the machine from service and correct the cause of the hydraulic leak before further operation.													

Frequent Inspection and Maintenance – Every 90 Days or 150 Hours

Item	Procedure	Information	P/F/R
Overload system test CE machines only	Check the lift function at 120% maximum load capacity. Start the test with the platform fully lowered. Verify that the lift function cuts out automatically, the alarm sounds and the red light on the control panel flashes before the platform reaches an elevation of approximately 1.8 m (6').	120% Maximum Load S3215L 366 kg (805 lb) S3215E 327 kg (720 lb) S3219E 300 kg (660 lb) S3220E 490 kg (1080 lb) S3226E 272 kg (600 lb) S4726E 544 kg (1200 lb) S4732E 381 kg (840 lb)	
Battery disconnect switch	Shuts off all controls		
Upper Controls			
Operating controls	Check for smooth operation and proper speed		
Parking brakes	Proper operation		
Emergency stop	Shuts off power to upper controls		
Lowering alarm—if equipped	Verify that alarm sounds while the platform is lowering		
Drive motion alarm –if equipped	Verify that alarm sounds while chassis is in motion		
Electrical power outlet	Check for proper operation of outlet and GFCI		
Travel speed	Verify proper travel speed		
	Low speed – all models: 0.4 mph (0.6 km/h)	0.4 mph = 50ft in 85 secs (0.6 km/h = 15.2m in 85 secs)	
	High speed – S3215E 2.4 mph (3.9 km/h)	2.4 mph = 50ft in 14 secs (3.9 km/h = 15.2m in 14 secs)	
	High speed – S3219E/S3215L 2.0 mph (3.3 km/h)	2.0 mph = 50ft in 17 secs (3.2 km/h = 15.2m in 17 secs)	
	High speed S3220E/S3226E/S4726E/S4732E 2.3 mph (3.7 km/h)	2.3 mph = 50ft in 15 secs (3.7 km/h = 15.2m in 15 secs)	
Horn	Check for wear and damage		
Battery condition indicator	Check for proper operation		
Options			
Flashing light	Check for proper operation		
Level Sensor Interlock Test	<p>A. Park the machine on a level surface. Place a smart level on the chassis in the front-to-back direction. Zero the level.</p> <p>B. Elevate the front tires to the approximate height as follows: S3215L/S3215E/S3219E 3 3/8" (86 mm) S3220E/S3226E/S4726E/S4732E 4 3/4" (121 mm)</p> <p>Verify the chassis inclination is no more than 3.7 degrees. Verify the platform will raise and lower through its full range of motion.</p> <p>Continued on next page...</p>		

Frequent Maintenance – Every 90 Days or 150 Hours

Item	Procedure	Information	P/F/R
Level Sensor Interlock Test	<p>C. Elevate the front tires to the approximate height as follows: S3215L 4" (102 mm) S3215E/S3219E 4 1/8" (105 mm) S3220E/S3226E/S4726E/S4732E 6" (152 mm)</p> <p>Verify the chassis inclination is between 4.2 and 4.4 degrees. Verify that the lift function cuts out automatically and the alarm sounds before the platform reaches an elevation of 6' (1.8 m). All drive functions must also cut out.</p> <p>D. Repeat steps B and C elevating the rear tires.</p> <p>E. Place the smart level on the chassis in the side-to-side direction. Zero the level. Elevate the front tires on the right side of the machine to the approximate height as follows: S3215L ANSI – 1" (25 mm) S3215L CE/AU – 3/4" (19 mm) S3215E/S3219E/S3220E/S3226E 3/4" (19 mm) S4726E/S4732E 1 1/8" (29 mm)</p> <p>Verify the chassis inclination is no more than 1.8 degrees, 1.2 degrees on the S3215L. Verify the platform will raise and lower through its full range of motion.</p> <p>F. Elevate the front tires on the right side of the machine to the approximate height as follows: S3215L ANSI – 1.25" (32 mm) S3215L CE/AU – 1" (25 mm) S3215E/S3219E/S3220E/S3226E 1" (25 mm) S4726E/S4732E 1 3/4" (44 mm)</p> <p>Verify the chassis inclination is between 2.2 and 2.4 degrees, 1.7 and 1.9 degrees on the S3215L. Verify that the lift function cuts out automatically and the alarm sounds before the platform reaches an elevation of 6' (1.8 m). All drive functions must also cut out.</p> <p>G. Repeat steps E and F for the left side of machine.</p> <p>H. Adjust/replace the level sensor as required.</p>		

Maintenance Table Key: P = Pass, F = Fail, R = Repaired

Performed by: _____ Date: _____

Model: _____ Serial Number: _____

Annual Maintenance – Every 500 Hours

Item	Procedure	Information	P/F/R
Frequent Maintenance Checklist	Complete Frequent Maintenance		
Hydraulic System			
Hydraulic fluid condition	Drain, flush, and clean hydraulic system. Refill with new fluid.	Above 10°F (-12°C) ISO VG32 Below 10°F (-12°C) ISO VG15	
Return filter	Replace	Refer to Parts Manual for filter part number	
System pressures	Check system relief pressure	System Relief Pressure S3215L Only 3,200 to 3,300 psi (220 to 227 bar) System Relief Pressure 2,900 to 3,100 psi (200 to 214 bar)	

Maintenance Table Key: P = Pass, F = Fail, R = Repaired

Performed by: _____ Date: _____

Model: _____ Serial Number: _____

Appendix D – Progressive Tilt

Model	At Platform Height	Maximum Slope Side-to-Side	Maximum Slope Front-to-Rear
S3215L	6'	4°	4°
	13.5'	2.7°	4°
	15'	1.2°	4°
S3215E	7'	4°	4°
	12.5'	3.7°	4°
	15'	1.5°	4°
S3219E	9'	4°	4°
	16'	1.5°	4°
	19'	0.7°	4°
S3220E	9.5'	4°	4°
	16.5'	1.3°	4°
	20'	1.0°	4°
S3226E 04- Serial Numbers	12'	2.5°	4°
	20.5'	1.5°	4°
	26'	0.5°	4°
S3226E 01- Serial Numbers	12'	2.5°	4°
	20.5'	1.5°	4°
	26'	1.5°	4°
S4726E	12'	4°	3.5°
	21.5'	2.5°	3.5°
	26'	1.2°	3.5°
S4732E	15.5'	4°	4°
	27.5'	2.0°	4°
	32'	1.2°	4°



Snorkel Product Warranty Policy

1. Snorkel warrants, its authorized sales and service centers (herein referred to as "SSC"), each new machine manufactured and sold by it to be free from defects in material and workmanship for a period of two (2) years from date of delivery to any customer. The warranty will apply subject to the machine being operated in accordance with the rules, precautions, instructions and maintenance requirements outlined in the relevant Snorkel Operator and Parts/Service manuals. Snorkel further warrants the structural components, specifically the mainframe chassis, turntable, booms and/or scissor arms of each new machine manufactured by it to be free from defects in material and workmanship for an additional period of three (3) years. Any such part or parts which, upon examination by the Snorkel Warranty Department or appointed representative, are found to be defective will be replaced or repaired by Snorkel through local authorized Dealers. The structural warranty specifically excludes adverse effects on the machine structure arising from damage, abuse or misuse of the equipment.
2. Machines may be held in an authorized Distributor/ SSC's stock for a maximum period of six (6) months from the date of shipment from Snorkel, before the warranty period is automatically initiated on each machine.
3. It is the responsibility of the Distributor/SSC to complete and return to Snorkel a Pre-delivery Inspection Record, Warranty Registration Form, before the act of rental / loan / demonstration of the machine or delivery to an end user. In the case of direct sale to end customers the same responsibility lies with the end customer.
4. Any end customer, SSC, distributor or dealer shall not be entitled to the benefits of this warranty and Snorkel shall have no obligations here under unless the "Pre-Delivery and Inspection Record" has been properly completed and returned to the Snorkel Warranty department within fifteen (15) days after delivery of the Snorkel product to the Customer or Dealer's demonstration / rental fleet. Snorkel must be notified, in writing, within ten (10) days, of any machine sold to a Customer from a Dealer/SSC's rental fleet during the warranty period.
5. Any part or parts which upon examination by the Snorkel Product Support Department are found to be defective within the specified warranty period, will be replaced or repaired at the sole discretion of Snorkel through its local Authorized Distributor/SSC, at no charge. Any parts replaced under warranty must be original Snorkel parts obtained through an authorized Snorkel Distributor/SSC unless expressly agreed otherwise in writing and in advance by Snorkel's warranty department.
6. All parts claimed under warranty must be held available for return and inspection upon request for a period of 90 days from date of claim submission, it is necessary that all parts are individually tagged or marked with their part number and the warranty claim number. All parts returning should be still in a factory state, free of any alteration to the original design. If the parts are subject to repair it will need to be pre authorized by the Snorkel Product Support Group and or Warranty Department prior to the repair being completed. After 90 days all parts replaced under warranty which have not been returned, to Snorkel should be destroyed. Failure to produce parts requested by the Warranty Administrator for inspection within a period of 14 days will result in the claim being automatically rejected in full. Materials returned for warranty inspection must have the following procedure:
 - Carefully packaged to prevent additional damage during shipping
 - Drained of all contents and all open ports capped or plugged
 - Shipped in a container tagged or marked with the RMA number
 - Shipped PREPAID (ground service only). Any item(s) returned for warranty by any other means
 - may be refused and returned, unless prior approval is agreed with Snorkel.



Snorkel Product Warranty Policy

7. At the direction of the Snorkel Warranty department, any component part(s) of Snorkel products to be replaced or repaired under this warranty program must be returned freight prepaid for inspection. An RMA (Returns material authorization) must be requested from Snorkel Warranty department, a copy to be placed with the returning component part(s).
8. All warranty replacement parts will be shipped freight prepaid (standard charges, ground shipping only) from the Snorkel Parts department, Service Department or from the Vendor to Dealer/SSC or Customer. Any other shipping method is the customer responsibility.
9. All warranty claims are subject to approval by Snorkel Service department. Snorkel reserves the right to limit or adjust claims with regard to defective parts, labor or travel time based on usual and customary guidelines.
10. Reimbursement policy, labor will be paid at 75% of posted hourly shop rate. Travel time will be paid at \$50 per hour up to a maximum of 3 hours. Snorkel will pay 1 hour of troubleshooting time per warranty claim, unless expressly agreed otherwise in writing and in advance by Snorkel's Warranty Department. An annual rate declaration must be supplied to the Snorkel Warranty administrator by January 31st and will be used as the reimbursable rate for that calendar year.

REPLACEMENT PARTS WARRANTY

- Any part replaced under this limited warranty is not subject to further warranty cover beyond the normal warranty period of the machine upon which the part was installed.
- Any replacement parts sold (not delivered under a warranty claim) will be subject to a warranty period of (6) six months from the date of invoice.
- Parts held by an authorized Distributor/SSC are covered under warranty for a period of (12) twelve months from the date of invoice, provided that those parts have been subject to appropriate storage to prevent damage and deterioration (conditional on Snorkel review).

CLAIM PROCEDURE

The Snorkel Warranty department must be notified within forty-eight hours (48) of any possible warranty situation during the applicable warranty period. Personnel performing major warranty repair or parts replacement must obtain specific approval by the Snorkel Warranty department prior to performing the warranty repair or replacement.

When a Distributor/SSC/Customer perceive a warranty issue to exist the following steps must be adhered to:

- Customer/SSC/Distributor to place a purchase order for genuine Snorkel replacement parts.
- Snorkel to dispatch parts via the requested method (in line with the required response time).
- Confirmation that a qualified technician is available to replace the part and that this person has been accepted by Snorkel to carry out such work under the warranty of the machine. Failure to do this may nullify the warranty.
- Customer/SSC/Distributor to allocate a warranty claim number to the repair.
- All correspondence in respect of the claim to be on an official Snorkel warranty claim form as supplied by Snorkel's warranty department.
- All warranty claims must be submitted within 30 days of the date of the machine repair.

FREIGHT DAMAGE

- If a machine is received in a damaged condition, then the damage must be noted on the bill of lading and/or delivery documents and photographs must be taken at the point of delivery, prior to signing acceptance of the consignment.
- The freight company and Snorkel must be contacted by the Distributor and a damage claim registered by either party immediately.
- The above requirements apply only to freight damage associated with equipment supplied by Snorkel transport. Customer freight issues are excluded from this warranty policy.



Snorkel Product Warranty Policy

THIS PRODUCT WARRANTY POLICY SPECIFICALLY EXCLUDES:

1. Engines, motors, tires and batteries are manufactured by specialist suppliers to Snorkel, who furnish their own warranty policies. Snorkel will, however, to the extent permitted pass through any such warranty protection to the Distributor/SSC/Customer.
2. Any Snorkel product which has been modified or altered outside Snorkel factories without written approval, if such modification or alteration, in the sole judgment of Snorkel Engineering and/or Service Departments, adversely affects the stability, reliability or service life of the Snorkel product or any component thereof.
3. Any Snorkel product which has been subject to misuse and abuse, improper maintenance or accident. "Misuse" includes but is not limited to operation beyond the factory-rated load capacity and speeds. "Improper maintenance" includes but is not limited to failure to follow the recommendations contained in the Snorkel Operation, Maintenance, and repair Parts Manuals.
4. Normal wear of any Snorkel component part(s). Normal wear of component parts may vary with the type, application or type of environment in which the machine may be used; such as, but not limited to sandblasting applications.
5. Routine maintenance, routine maintenance items and minor adjustments are not covered by this warranty, including but not limited to hydraulic fluid, filters and lubrication, paint and decals, engine tune-up, brake adjustments etc. Snorkel will not cover leaks from fittings, hoses and any other connection points after the unit has been in service for 90 days or 150 hours of operation which ever comes first.
6. Any Snorkel product that has come into direct contact with any chemical or abrasive material.
7. Incidental or consequential expenses, losses, or damages related to any part or equipment failure, including but not limited to freight cost to transport the machine to a repair facility, downtime of the machine, lost time for workers, lost orders, lost rental revenue, lost profits, expenses or increased cost. This warranty is expressly in lieu of all other warranties, representations or liabilities of Snorkel, either expressed or implied, unless otherwise amended in writing by Snorkel.
8. Snorkel warranty policy does not cover any duties, taxes, environmental fees including without limitation, disposal or handling of tires, batteries and petrochemical items.
9. Items specifically excluded are: fuel injectors, motor brushes, glow plugs, contactor tips and springs, filters, lamp bulbs, lamp lenses, coolants, lubricants, brake pads and cleaning materials.
10. Failure of replacement parts due to fault misdiagnosis or incorrect fitting by the Distributor/SSC/Customer.

SNORKEL MAKES NO WARRANTIES WHICH EXTEND BEYOND THE DESCRIPTION OF THIS LIMITED WARRANTY. SNORKEL MAKES NO IMPLIED WARRANTY OF MERCHANTABILITY OR FITNESS FOR A PARTICULAR PURPOSE AND DISCLAIMS ALL LIABILITY FOR INCIDENTAL OR CONSEQUENTIAL DAMAGES, INCLUDING BUT NOT LIMITED TO INJURY TO PERSONS OR PROPERTY.



Snorkel Product Warranty Policy

Wherever possible the end customer shall obtain all warranty support and make all warranty claims through the local Snorkel authorized Distributor/SSC/Dealer. Warranty support should be from the Distributor/SSC/Dealer from whom the Snorkel product was purchased. Where Snorkel equipment is supplied directly from the factory the end customer, or if unable to contact the Distributor/SSC/Dealer, may contact the Snorkel Warranty Department for further assistance.

APPEAL

The buyer may appeal in writing against a rejected or adjusted claim to Snorkel warranty department within a period of 21 days of receiving the rejection or adjustment notice. The appeal should be grounded on express reasons and supported by relevant evidence. Appeals received outside of this time limit will not be considered.

SNORKEL WARRANTY SCHEDULE

Limited Warranty Periods

Item	Warranty Period
New machine materials and workmanship	2 year parts replacement
Structural components (Chassis, Turntable, Booms, Scissors)	5 years parts replacement or repair
Parts held in a Distributor's stock	12 months from date of invoice, subject to adequate storage/protection
Parts sold (non warranty)	6 months from date of invoice
Batteries supplied on new machines	6 months from warranty registration date
Other specifically excluded parts: Fuel injectors Motor brushes Glow plugs Contactor tips and springs Oils Filters Lamp bulbs Lamp lenses Coolants Lubricants Cleaning materials All consumable/wear parts	Not covered by Warranty

Manufacturer's Address
Snorkel International LLC
8350 Eastgate Road
Henderson, NV 89015 USA

Authorized Representative
Snorkel Europe Ltd
Vigo Centre, Birtley Road
Washington, Tyne & Ware, NE38 9DA, UK

**Local Distributor / Lokaler Vertiebshändler / Distributeur local
El Distribuidor local / Il Distributore locale**

**EUROPE, MIDDLE EAST
AFRICA & ASIA**

PHONE: +44 (0) 845 1550 058
FAX: +44 (0) 845 1557 756

NORTH & SOUTH AMERICA

PHONE: +1 785 989 3000
TOLL FREE: +1 800 255 0317
FAX: +1 785 989 3070

AUSTRALIA

PHONE: +61 1300 700 450
FAX: +61 2 9609 3057

NEW ZEALAND

PHONE: +64 6 3689 168
FAX: +64 6 3689 164



www.snorkellifts.com