

nifty

SD50

Operating & Safety Instructions MODEL SD50 SERIES

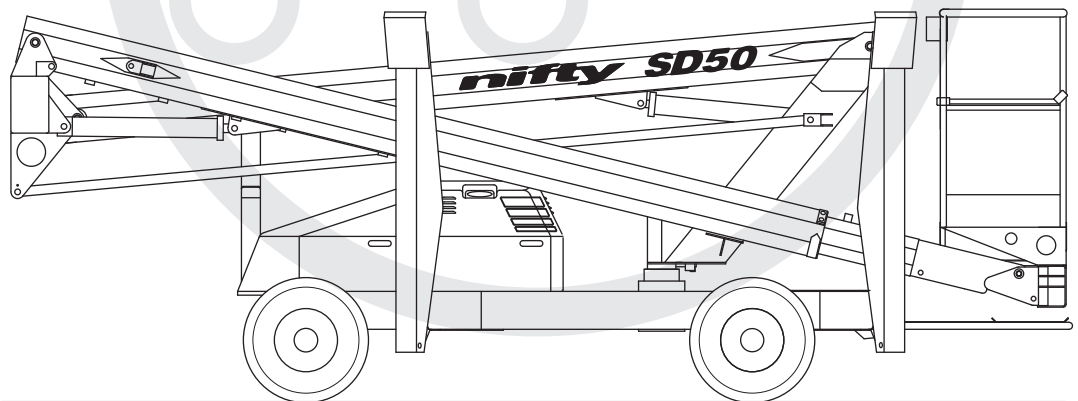

niftylift.com
info@niftylift.com

M50906/03



Niftylift Limited
1525 S. Buncombe Road
Greer
SC 29651
USA

www.niftylift.com
e-mail: niftyusa@niftylift.com
Tel: 864-968-8881
Fax: 864-968-8836

Table of Contents

1	INTRODUCTION AND GENERAL INFORMATION	PAGE
1.1	Foreword	2
1.2	Scope	3
1.3	Introducing the SD50 Self Drive (SD) Series	3
1.4	General Specification	4
1.5	Identification	5
2	SAFETY	
2.1	Mandatory Precautions	6-9
2.2	Environmental Limitations	10
2.3	Noise & Vibration	10
2.4	Test Report	11
3	PREPARATION AND INSPECTION	
3.1	Unpacking	12
3.2	Preparation for Use	12
3.3	Pre-Operational Safety Check Schedules	13-15
3.4	Placard, Decals and Installation	16-18
3.5	Torque Requirements	19
4	OPERATION	
4.1	Control Circuit Components	20-22
4.2	Setting up Procedures	23
4.3	Ground Control Operation	24-25
4.4	Basket Control Operation	26-28
4.5	Driving Controls	29
4.6	Batteries and Charging	30-32
4.7	Transporting, Towing, Craneage, Storage and Setting to Work	33-35
5	EMERGENCY CONTROLS	
5.1	General	36
5.2	Emergency Procedures - Incapacitated Operator	36
5.3	Emergency Procedures - Machine Failure	36
5.4	Incident Notification	36
6	RESPONSIBILITIES	
6.1	Changes in Ownership	37
6.2	Manual of Responsibilities	37
6.3	Inspection/Service/Pre-Hire Check List	38-39

1 Introduction and General Information

1.1 FOREWORD

The purpose of these manuals is to provide the customer with proper safety operating and maintenance instructions essential for proper machine operation.

All information in these manuals should be **READ** and fully **UNDERSTOOD** before any attempt is made to operate the machine. **THESE MANUALS ARE VERY IMPORTANT TOOLS** - Keep them with the machine at all times.

The manufacturer has no direct control over machine application and use, therefore conformance with good safety practices is the responsibility of the user and his operating personnel.

All information in these manuals is based on the use of the machine under proper operating conditions. Alteration and/or modification of the machine are strictly forbidden.

One of the most important facts to remember is that any equipment is only as safe as those who operate it.

DANGER, WARNING, CAUTION, IMPORTANT, INSTRUCTIONS AND NOTICE

Any place these topics may appear, either in this manual or on the machine, they are defined as follows:

DANGER: If not correctly followed there is a high probability of serious injury or death to personnel.

WARNING OR CAUTION: If not correctly followed there is some possibility of serious injury or death to personnel.



THE **'SAFETY ALERT'** SYMBOL IS USED TO CALL ATTENTION TO POTENTIAL HAZARDS WHICH MAY LEAD TO SERIOUS INJURY OR DEATH, IF IGNORED.

IMPORTANT AND INSTRUCTIONS: Denotes procedures essential to safe operation and prevention of damage to or destruction of the machine.

NOTICE: Indicates general safety rules and/or procedures relating to the machine.

It is the owner's/user's responsibility to know and comply with all applicable rules, regulations, laws, codes and any other requirements applicable to the safe use of this equipment.

1.2 SCOPE

These operating instructions contain all the necessary information required to allow the safe operation of Niftylift SD50, powered by electric (DC), diesel or gasoline engine, or a combination of these.

For further technical information, circuit diagrams and specific instructions for all maintenance which may need to be carried out by specialist trained personnel, see the associated Workshop and Parts manual for your model of machine.

1.3 INTRODUCING THE SD50 SELF DRIVE SERIES

Please note at the time of going to press all information, illustrations, details and descriptions contained herein are valid. Niftylift reserves the right to change, alter, modify or improve its products without any obligations to install them on previously manufactured machines.

If you require further information after reading this manual, please do not hesitate to contact us at your nearest office.

Niftylift Inc, 1525 S. Buncombe Road, Greer, SC 29651 USA

Tel: **864 968 8881** Fax: **864 968 8836** Email: **niftyusa@niftylift.com**

The Niftylift SD (Self Drive) is a range of extremely versatile articulating boom mounted via a 360° powered swing mechanism. Driven from the basket, the Niftylift SD50 Self Drive accommodates up to two men and their equipment, and offers a working height of up to 17m (56ft) or an outreach of 28ft 5in with a maximum capacity of 500lb.

High traction tyres and hydraulic wheel motors give 30% gradeability for 4WD versions with the option of slow or fast drive speed. Automatic braking and audible alarms activated by tilt sensor help to prevent the operator from working on unsafe terrain. The outriggers make a swift set up possible and minimise the weight of the machine. A unique pressure sensitive micro switch system fitted to each outrigger prevents operation of the machine until all outriggers have been correctly deployed and also provides a loud audible alarm warning of a possible hazardous situation

A simple, all-hydraulic proportional control system gives smooth, reliable movement of the basket and maximum reliability in the harshest environments.

The Niftylift Self Drive provides a fast, safe, cost effective method of access, both inside and out, for a multitude of applications where overhead working is required.

This product conforms to ANSI/SAIA A92.20-2018.

Models Include the Following:-

E: - D.C. ELECTRIC	DE: - BI-ENERGY (DIESEL & BATTERY)
D: - DIESEL	GE: - GASOLINE & BATTERY

1.4 GENERAL SPECIFICATION

FEATURE	SD50
MAXIMUM HEIGHT - WORKING	56ft 1in
MAXIMUM HEIGHT - BASKET	49ft 6in
MAXIMUM HEIGHT - STOWED	6ft 11in
MAXIMUM OUTREACH	28ft 6in
MAXIMUM WIDTH	5ft 3in
MAXIMUM LENGTH - STOWED	18ft 4in
MAXIMUM CAPACITY	500lb
TURRET ROTATION	355°
TURRET TAILSWING	Zero
BASKET SIZE - LENGTH x WIDTH	25in x 44in
CONTROLS	Full proportional hydraulic
HYDRAULIC PRESSURE	200bar
GRADEABILITY	30%
TRAVEL SPEEDS	Fast: 5.2mph Slow: 1.2mph
GROUND CLEARANCE	6in
GROSS VEHICLE WEIGHT	5688lbs - 6085lbs
MAXIMUM GROUND PRESSURE	7100lb/ft ²
MAXIMUM ALLOWABLE INCLINATION	0.5°
POWER OPTIONS	E (Electric) models - 4 x 6v 250 AH batteries D (Diesel) models - Kubota 722

1.5 IDENTIFICATION (USA PLATE)

		
NIFTYLIFT LTD., CHALKDELL DRIVE, SHENLEY WOOD MILTON KEYNES MK5 6GF GREAT BRITAIN TEL (01144) 1908 223456 : FAX (01144) 1908 312733 e-mail: info@niftylift.com		
SERIAL No		
MODEL		
YEAR OF MANUFACTURE		
WEIGHT		kg (lbs)
RATED LOAD	PERSONS +	kg (lbs)
MAXIMUM SAFE WORKING LOAD		kg (lbs)
MAXIMUM PULL		N (lbf)
MAXIMUM WIND SPEED		m/s (mph)
MAXIMUM ALLOWABLE INCLINATION		deg
MAXIMUM HYDRAULIC PRESSURE		psi
MAXIMUM VOLTAGE		V
MAXIMUM AMPS		A
ELECTRICAL SCHEMATIC D	ISSUE	
HYDRAULIC SCHEMATIC D	ISSUE	
PLATFORM HEIGHT		feet
PLATFORM REACH		feet
TYPE	GROUP	
		P33792/1

This manufacturer's plate is attached to Boom 1 on each machine at the time of manufacture on every Niftylift. Please ensure all sections have been stamped and are legible.

2 Safety

2.1 MANDATORY PRECAUTIONS

When operating your Niftylift, your safety is of utmost concern. In order to fully appreciate all aspects of the machines operation it should be ensured that each operator has **READ** and fully **UNDERSTOOD** the relevant manual covering machine use, maintenance and servicing. If any doubts exist concerning any points covered in your manual, contact your local dealer or Niftylift Ltd.

Before using any Niftylift, thoroughly inspect the machine for damage or deformation to all major components. Likewise, check the control systems for hydraulic leaks, damaged hoses, cable faults or loose covers to electrical components. At no time should damaged or faulty equipment be used - Correct all defects before putting the basket to work. If in doubt, contact your local dealer or Niftylift Ltd (see front cover for address).



THE MANUFACTURER HAS NO DIRECT CONTROL OVER THE MACHINE APPLICATION AND USE. THEREFORE CONFORMATION WITH GOOD SAFETY PRACTICES IS THE RESPONSIBILITY OF THE USER AND HIS OPERATING PERSONNEL. FAILURE TO UNDERSTAND AND FOLLOW ALL SAFETY RULES COULD RESULT IN SERIOUS INJURY OR DEATH.

- 2.1.1** Only authorised persons trained on the same or a similar model will be permitted to operate the aerial Niftylift.
- 2.1.2** Always operate the Niftylift in full accordance with the manufacturers Operating & Safety Instructions for that model.
- 2.1.3** Before use each day and at the beginning of each shift the Niftylift shall be given a visual inspection and functional test including, but not limited to, operating and emergency controls, safety devices, personal protective clothing, including fall protection, air, hydraulic and fuel system leaks, cables and wiring harness, loose or missing parts, tyres and wheels, placards, warnings, control markings and Operating and Safety Manuals, guards and guard rail systems and all other items specified by the manufacturer.
- 2.1.4** Any problems or malfunctions that affect operational safety must be repaired prior to use of the basket, with specific regard to any safety components refer to the Parts Manual for part numbers and details. If in doubt, contact Niftylift Ltd (Details on page 3). **Ensure wheels are chocked before carrying out any maintenance that involves brake release as described in Section 4.8.2 – Towing.**
- 2.1.5** Always ensure that all warning labels, instructions, placards, control markings and Safety Manuals are intact and clearly legible. If replacements are required contact your local dealer or Niftylift. Always observe and obey safety and operating instructions on such labels.
- 2.1.6** Do not alter, modify or disable in any way the controls, safety devices, interlocks or any other part of the machine.
- 2.1.7** Before the Niftylift is used and during use the user shall check the area in which it is to be used for possible hazards such as, but not limited to, uneven ground drop-offs, holes, bumps, obstructions, debris, floor and overhead obstructions, high voltage conductors, wind and weather, unauthorised persons and any other possibly hazardous conditions.
- 2.1.8** Never exceed the maximum basket capacity, as indicated on the decals and machine serial plate.

- 2.1.9** Only operate the Niftylift on a firm, level surface.
- 2.1.10** Never position any part of the Niftylift within the Minimum Approach Distances of any electrical power line, conductor, or similar stated in Occupational Safety and Health Administration Regulations for CFR 1910.333(c) for Minimum Approach Distance for electrical wires.
1910.333(c)(3)(i)(A)(1): For voltages to ground **50kV or below** - 10 feet (305 cm);
1910.333(c)(3)(i)(A)(2): For voltages to ground **over 50kV** - 10 feet (305 cm) plus 4 inches (10 cm) for every 10kV over 50kV.

**THIS MACHINE IS NOT INSULATED.**

If in doubt, contact the appropriate authorities

- 2.1.11** On entering the basket, ensure that the drop down entry bar is closed afterwards.
- 2.1.12** Use of an approved safety belt and lanyard, hard hat and appropriate safety clothing is mandatory. Fasten harness to designated harness securing points within the basket and do not remove until leaving the basket whilst in the stowed position.

2.1.13

Always remain standing within the basket. Do not attempt to increase your height or reach by standing and/or climbing on the basket guard rails or any other object. **KEEP YOUR FEET ON THE BASKET FLOOR.** Do not sit, stand or climb on the guard rail, mid rail or boom linkage. Use of planks, ladders or any other devices on the Niftylift for achieving additional height or reach shall be prohibited.

- 2.1.14** To obtain the correct basket position above the ground when initially setting up the machine, use the base functions for booms and telescope to position the basket for safe entry.



THE BASKET FLOOR MUST BE WITHIN 400MM (16IN) OF THE GROUND WHEN ENTERING OR EXITING. DO NOT CLIMB IN OR OUT OF THE BASKET WITH THE BOOMS IN THE TRANSPORT POSITION.

- 2.1.15** Do not use the basket levelling system to artificially increase the outreach of the basket. Never use boards or ladders in the basket to achieve the same result.
- 2.1.16** Do not use the basket to lift overhanging or bulky items which may exceed the maximum capacity or carry objects which may increase the wind loading on the basket.
- 2.1.17** The Niftylift shall not be operated from a position on trucks, trailers, railway cars, floating vessels, scaffolds or similar equipment unless the application is approved in writing by Niftylift Ltd in Great Britain.
- 2.1.18** Before lowering or rotating the booms, always check below and around the basket to ensure that the area is clear of personnel and obstructions. Care should be taken when rotating the booms out into areas where there may be passing traffic. Use barriers to control traffic flow or prevent access to the machine.
- 2.1.19** Stunt driving and horseplay, on or around the Niftylift, shall not be permitted.
- 2.1.20** When other moving equipment and vehicles are present, special precautions shall be taken to comply with local ordinances or safety standards established for the work place. Warnings such as, but not limited to flags, roped off areas, flashing lights and barricades shall be used.

Operating & Safety Instructions

- 2.1.21** Before and during driving while the basket is elevated the operator shall maintain a clear view of the path of travel, maintain a safe distance from obstacles, debris, drop offs, holes, depressions, ramps and other hazards to ensure safe elevated travel. Maintain a safe distance from overhead obstacles.
- 2.1.22** Under all travel conditions the operator shall limit travel speed according to conditions of ground surface, congestion, visibility, slope, location of personnel and other factors causing hazards of collision or injury to personnel.
- 2.1.23** The aerial platform shall not be driven on grades, side slopes or ramps exceeding those for which the aerial basket is rated by the manufacturer.
- 2.1.24** It shall be the responsibility of the user to determine the hazard classification of any particular atmosphere or location. Aerial baskets operated in hazardous locations shall be approved and suitable for the duty. (See ANSI/NFPA 505 where applicable).
- 2.1.25** The operator shall immediately report to his supervisor any potentially hazardous location(s) (environment) which become evident during operation.
- 2.1.26** If an operator encounters any suspected malfunction of the Niftylift or any hazard or potentially unsafe condition relating to capacity, intended use or safe operation, he shall cease operation of the Niftylift and request further information as to safe operation from his management, or owner, dealer or manufacturer before further operation of the Niftylift.
- 2.1.27** The operator shall immediately report to his superior any problems or malfunctions of the Niftylift, which becomes evident during operation. Any problems or malfunctions that affect the safety of operation shall be repaired prior to continued use.
- 2.1.28** The boom and basket of the Niftylift shall not be used to jack the wheels off the ground.
- 2.1.29** The Niftylift shall not be used as a crane.
- 2.1.30** The Niftylift shall not be positioned against another object to steady the basket.
- 2.1.31** Care should be taken to prevent rope, electric cords and hoses from becoming entangled in the aerial platform.
- 2.1.31** Batteries shall be recharged in a well ventilated area free of flame, sparks or other hazards (e.g. do not smoke near the machine) which may cause explosion. Highly explosive hydrogen gas is produced during the charging process.
- 2.1.33** When checking electrolyte levels great care should be taken to protect eyes, skin and clothing. Battery acid is highly corrosive and protective glasses and clothing is recommended.
- 2.1.34** If the basket or elevating assembly becomes caught, snagged or otherwise prevented from normal motion by adjacent structure or other obstacles, such that control reversal does not free the basket, all personnel shall be removed from the basket safely before attempts are made to free the basket using ground controls.

2.1.35

When the machine is not in use always stow the booms correctly. **NEVER LEAVE THE KEYS IN THE MACHINE**, if it is to be left for any period of time. Use wheel chocks if leaving on an incline.

2.1.36

The engine must be shut down while fuel tanks are being filled. Fuelling must be done in a well ventilated area free of flame, sparks or any other hazard which may cause fire or explosion. **GASOLINE, LIQUID PROPANE AND DIESEL FUELS ARE FLAMMABLE.**

2.1.37

NEVER START THE NIFTYLIFT IF YOU SMELL GASOLINE, LIQUID PROPANE OR DIESEL FUEL. THESE FUELS ARE HIGHLY FLAMMABLE

2.1.37

The operator must ensure that engine powered machines are used in a well-ventilated area to minimise the risk of carbon monoxide poisoning.

2.1.38

The operator shall implement means provided to protect against use by unauthorised persons.

2.1.39

Never remove anything that may affect the stability of the machine such as, but not limited to, batteries, covers, engines, tyres or ballast.

2.1.40

The operator must ensure that the controls are not obstructed (e.g. by tools or equipment) and **clear access to the Emergency Stop** is available at all times.

2.1.41

All persons in the cage must take suitable precautions to prevent items falling or being ejected from the cage. E.g. Tethering tools to the machine or operator if practical and an assessment of any resulting risks is acceptable.

2.1.42

Hydraulic oil escaping under pressure can penetrate the skin and cause **serious injury**. Do not allow hydraulic oil to squirt or spray. **Seek immediate medical attention in the event of hydraulic oil penetrating the skin.** Wear chemical-resistant protective gloves and suitable eye protection when handling hydraulic oil. Relieve system pressure before removing any hydraulic connections, undo fittings slowly to make sure there is no residual pressure. If pressure is detected, allow it to be released slowly before completely removing hose. Fluid leaks may not be visible to the naked eye. Use a piece of cardboard to check for leaks, not your hand. **Never** install hydraulic lines or components that are damaged.

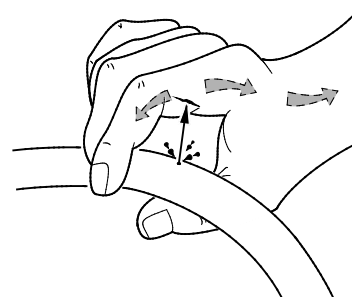
**2.1.43**

Only Niftylift original and supplied parts shall be used. Replacement of parts should only be carried out by appropriately trained and competent persons.

2.2 ENVIRONMENTAL LIMITATIONS

All Niftylift Self Drives are limited to operation as previously described. Unless specifically configured otherwise, the machine will have short time rating for operation in extreme temperatures, i.e. reduced battery cycle times for low temperatures, e.g. freezers, food storage etc, cooling limitations for high temperatures, i.e. oil temperature not to exceed -23 to 93° Celsius.

The recommended operational range for these machines is - 5°C to +30°C. Please contact Niftylift Ltd for special considerations if the machine is required to operate outside these temperatures.

Extended operation in dusty environments is not recommended, frequent cleaning will be necessary. All dust, dirt, salt encrustation, excess oil or grease should be removed. Deposits of paint or bitumen, particularly on legends or labels should be removed.

All standard Niftylift machines are rated for a wind speed of 28mph or force 6 on the Beaufort scale. No attempt should be made to operate a Niftylift in wind strengths above this limit and if the operator has any doubts over the wind speed he / she should cease operation immediately until it can be established that the wind speed has fallen to a safe level.



DO NOT USE THE NIFTYLIFT IN ELECTRICAL STORMS

2.3 NOISE AND VIBRATION

The airborne noise emission on the SD50 range of machines does not exceed 85dB(A), measured at a perpendicular distance of 4m, under equivalent continuous A-weighted sound pressure test conditions. This was based on a Diesel powered machine, working on high throttle, and under load. All other models will exhibit significantly lower emissions than this figure, dependant on power option.

In normal operation the Vibration level to which the operator is subjected will not exceed a weighted root mean square acceleration value of 28mph.

2.4 TEST REPORT

All Niftylift machine models are subjected to a comprehensive 'type test' which duplicates all combinations of safe working load (SWL), overload, windage, inertia and pull force to assess the various safe stability criteria. Self propelled machines are also subjected to kerb and braking tests at the SWL to satisfy additional 'worse case' stability requirements.

Each individual machine is then subjected to static overload tests on flat level ground with 150% of the SWL, exceeding the requirements of ANSI A92.20 for power operated MEWPs. Self propelled machines are also tested at the maximum working angle **plus** 0.5° with a test load of 125% of the SWL. Finally, on all machines, a functional test is performed with 110% of SWL.

All safety devices are checked for correct operation, operating speeds are checked against benchmark figures and the dynamic functions ensure that all acceleration and deceleration forces are within acceptable limits. All noted defects are rectified and recorded before the machine is permitted to enter service.

2.5 ELECTRICAL SAFETY

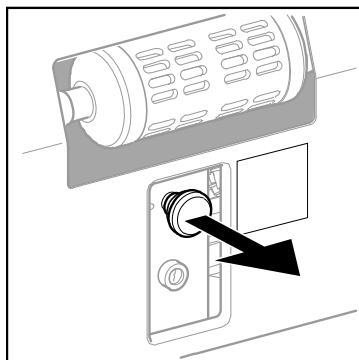

Machines are electrically isolated prior to shipment and require reconnection before use as shown.

3 Preparation and Inspection

3.1 UNPACKING

Since the manufacturer has no direct control over the shipping or carriage of any Niftylift it is the responsibility of the dealer and/or owner and/or leaser to ensure the Niftylift has not been damaged in transit and a Pre-operational Report has been carried out by a qualified engineer before the aerial basket is put into service.

- A) Remove all ropes, straps and or chains used to secure the aerial basket during transit.
- B) Ensure any ramp, loading dock or fork lift used is capable of supporting or lifting the aerial basket.
- C) If the aerial platform is to be driven off, please ensure that the operator has read and fully understood this entire manual. Refer to the appropriate section for precise operating instructions.

*****Carry out the Inspection/service/pre-hire check list (see pages 36 & 37) before placing machine in service.**

3.2 PREPARATION FOR USE

Whilst every effort has been made at the Niftylift factory to ensure your machine arrives in a safe and operable condition it is necessary to carry out a systematic inspection prior to putting the aerial basket into service.



THIS IS NOT A REQUEST IT IS MANDATORY

To assist the user in this task you will find enclosed a Inspection/service/pre-hire check list, which must be filled out upon delivery/receipt of the machine.

Before the user carries out the Pre-operational Report he must have read and fully understood all the contents of the Operating, Safety and Maintenance Manual.



WARNING - FAILURE TO COMPLETE THE INITIAL PRE-OPERATIONAL REPORT AND RETURN THE TOP COPY TO NIFTYLIFT RENDERS THE WARRANTY INVALID.

WARNING - DO NOT OPERATE A POTENTIALLY DEFECTIVE OR MALFUNCTIONING MACHINE. CORRECT AND REPAIR ANY DEFECTS BEFORE OPERATING YOUR NIFTYLIFT.

3.3 PRE-OPERATIONAL SAFETY CHECK SCHEDULES

Before use at the beginning of the work shift, the aerial platform shall be given a visual inspection and functional tests including, but not limited to the following. It is recommended that these be performed at regular intervals as indicated on each checklist.

3.3.1 DAILY SAFETY CHECKS

- 1) Check that all labels (decals) are in place and legible.
- 2) Visually inspect the machine for damaged or loose components.
- 3) Check that batteries are charged i.e. Charger has a solid green light and a pulsing red light.
- 4) Check the fuel level (if applicable).
- 5) Check that canopies/covers and guards are in place and secure.
- 6) Check that the boom rest switch is operable (if applicable).
- 7) Check that control levers are secure and operate freely.
- 8) Check that operating buttons and emergency stop buttons function properly.
- 9) Check the operation of the manual hand pump.
- 10) Visually inspect all hydraulic hoses and fittings for damage or leaks.
- 11) Check operation of the stabiliser alarm.
- 12) Check that outrigger footpads are secure.
- 13) Check that the basket pivot pins and their tag bolts are secure.
- 14) Check security and operation of the boom clamp.
- 15) Check that the tilt alarm is functioning correctly.
- 16) Check the operation of the basket weigh system (If fitted). See section 4.5.3 for testing and verification procedure.

3.3.2 WEEKLY SAFETY CHECKS

- 1) Inspect tyres and wheels for damage and wear.
- 2) Check tyres for correct pressure. 30psi (2,1 bar)
- 3) Check battery fluid levels and specific gravity (after charging) and general condition.
- 4) Check hydraulic oil level, ISO Grade 22 (Europe), Grade 32 (Rest of World).
- 5) Inspect the engine air filter and clean or replace if necessary.
- 6) Check operation and security of stabiliser micro switches in conjunction with the alarm system.
- 7) Check operation of the tilt sensor.
- 8) Inspect hose track for damage or missing parts.

Operating & Safety Instructions

3.3.3 MONTHLY SAFETY CHECKS

- 1) Check the engine oil level (if applicable).
- 2) Inspect the engine fuel tank for damage or leaks.
- 3) Check the condition of the fuel filter and hydraulic oil filter.
- 4) Check hydraulic hoses for cracks, leaks, blistering and excessive abrasion.
- 5) Check the wheel nuts (torque 65ft lbs / 86Nm).
- 6) Check outriggers for condition, security and operation.
- 7) Check that the rotation worm gear is secure and correctly in mesh. Clean and re-grease.
- 8) Inspect brakes for operation and wear.
- 9) Grease the knuckle and centre post.
- 10) Check telescopic boom wear pads and nylon studs (if applicable).
- 11) Check that the end cap on the main knuckle pin is secure and the roll pin is in place.
- 12) Lightly oil the outrigger pad ball joints and outrigger housings.
- 13) Lightly oil the locating pins on outriggers and axles and the axle clamp bolts.
- 14) Check that the bolts holding the wheel motors to the chassis are secure.
- 15) Check and adjust if necessary the Nylatron studs around the telescope boom.

3.3.4 ANNUAL SAFETY CHECKS

- 1) Check that all pivot pins and their tag bolts are secure.
- 2) Inspect for any cracks or badly rusted areas on booms and chassis.
- 3) Change the hydraulic oil and the oil filters.
- 4) Inspect the suspension on each rear axle unit.
- 5) Check that boom rotation ring gear bolts are secure (torque 218ft lbs. 295Nm).
- 6) Check hydraulic pumps and motors for cracks and leaks, loss of operating speed, excessive heating of fluid and pressure loss.
- 7) Check hydraulic cylinders for drifting caused by fluid leak across the holding valve or piston, rod seal leakage, scored or nicked cylinder rods, dented barrel and unusual noises or vibration.

3.3.5 STRUCTURAL INSPECTION

A structural inspection is required to verify the structural integrity of critical components of the aerial platform and for its stability as originally manufactured in accordance with the Standard in effect at the time of manufacture.

It shall be performed **10 years** after the date of manufacture and every **5 years** thereafter or after any actual, suspected, or potential damage is sustained during an incident that could potentially affect the structural integrity or stability of the aerial platform. Such incidents can include electrical contact, shock loads, fall arrest, collision, or cases of overstressing or stability failure; and after a change of ownership, unless a complete service history is provided, including maintenance and inspection records.

The structural inspection shall be carried out under the direction of a professional engineer and must;

- a) Consider the service history of the aerial platform in terms of hours of service, severity and number and variability of users;
- b) Review the inspection and maintenance record of the aerial platform;
- c) Verify the effectiveness of all operating controls;
- d) Perform a visual inspection of the aerial platform; and
- e) Consider recommendations of the manufacturer relevant to the aerial platform, including manufacturer's safety bulletins.

The structural inspection should use some or all of the following methods;

- a) Visual inspection of structural welds;
- b) Non-destructive testing of critical components; and
- c) Stability tests where modification, alteration, or damage is suspected.

Visual weld inspection shall be performed and documented by a person qualified to the requirements of CSA W178.2 or by other persons qualified to the satisfaction of the authority having jurisdiction.

Critical, suspect areas and other inconsistencies identified shall be further examined by an appropriate non-destructive test method by a person(s) qualified to the requirements of CAN/CGSB-48.9712.

Operating & Safety Instructions**3.4 PLACARD, DECALS & INSTALLATION**

ITEM	DESCRIPTION	NUMBER	QTY	
1	Serial Plate	P32187	1	
2	If E-Stop disabled...	P14864	3	
3	Tilt alarm	P18842	2	
4	Overload Warning	P18848	2	
5	Head Protection	P14921	1	
6	Booms to Drive/Jacks	P22587	1	
7	General Warning - Icons	P29379	2	
8	General Warning – Text	P29380	2	
9	Cage gate	P18432	1	
10	Clunk Click	P19961	2	
11	Harness Point	P32301	2	
12	Footswitch	P14884	1	
13	Operating Instructions	P14892	1	
14	Cage tie-down warning	P21404	2	
15	SWL 200kg	P14801	1	
16	Niftylift.com	P14390	1	
17	Hydraulic Controls – 5 lever	P14927	1	
18	Cage rotation	P15634	1	
19	Cage levelling	P10853	1	
20	IPAF - Are you trained?	P22055	1	
21	Base Control	<i>Cage weigh</i> <i>Non cage weigh</i>	P17219 P15881	1 1
22	Nifty SD170 - Grey	P14600	2	
23	Hydraulic Controls – 4 lever	P14928	1	
24	Manual Hand Pump	P19090	1	
25	Brake Override	P19986	1	
26	Emergency Controls	P22877	1	
27	Point Load - 17.5 kN	P14967	4	
28	General Crush	P14782	8	
29	No Step	P14785	6	
30	Diesel ONLY	P14414	1	
31	Hydraulic Oil	ISO22 ISO32	P14415 P17226	1 1
32	Trip Switch Reset	P19056	1	
33	General Notice	P21941	1	
34	Daily Checks	P14908	1	
35	Outriggers - Hydraulic	P14841	4	
36	Battery Charger	P21951	1	

37	Noise Warning		P17124	1
38	Battery Disconnect		P19700	1
39	Drive Wheel Lock		P19444	1
40	Outriggers		P16363	1
41	Drive/Steer		P15637	1
42	Warning Stripes			A/R
43	Rotating machinery		P15010	2
44	Safe Entry Cage		P18192	1
45	E-Stop background - Yellow		P24893	1
46	ANSI compliance		P25250	1
47	CSA compliance		P25120	1
48	CSA inspection		P25150	1
49	Max platform height		P25190	1
50	Charger socket	110V	P26424	1
		230V	P26863	1
52	Power to cage socket	110V	P26426	1
		230V	P26862	1
54	Battery cover access		P32030	2
55	Power to cage (tool)	110V	P33012	1
		230V	P33011	1
57	Annual inspection		P33474	1
59	Tyre pressure 30 psi		P33712	4

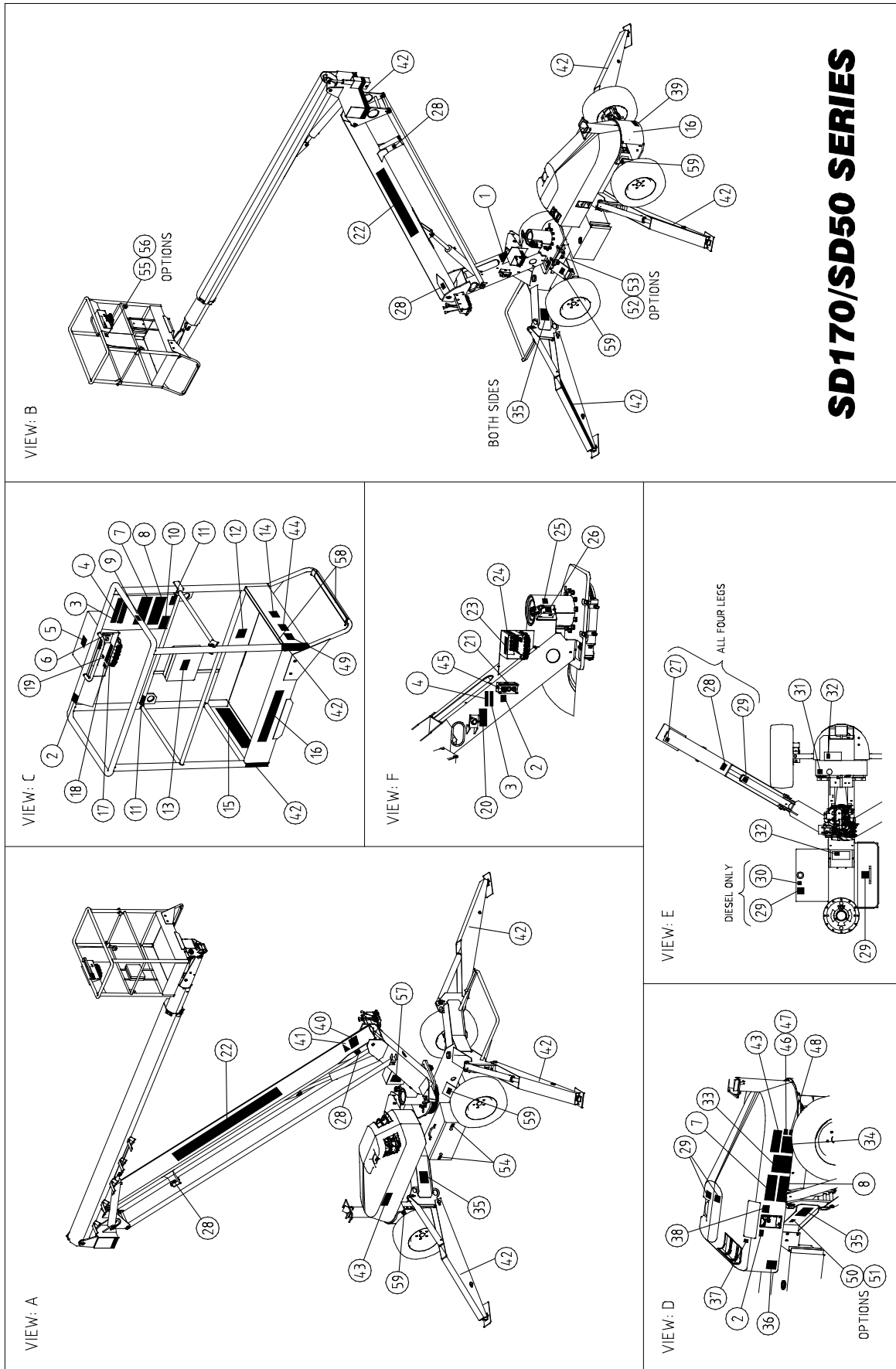

3.5 TORQUE REQUIREMENTS

BOLT QUALITY/SIZE	Tightening torque in lbs ft (Nm)					
	Plated			Unplated		
Grade	8.8	10.9	12.9	8.8	10.9	12.9
M 6	5 (7)	8 (10)	9 (12)	6 (8)	8 (11)	10 (13)
M 8	13 (17)	18 (25)	22 (29)	14 (19)	20 (27)	23 (32)
M 10	25 (34)	36 (49)	43 (58)	27 (37)	40 (54)	46 (63)
M 12	43 (58)	63 (85)	73 (99)	47 (63)	69 (93)	80 (108)
M 14	68 (93)	100 (135)	117 (158)	74 (101)	109 (148)	127 (172)
M 16	106 (143)	154 (209)	180 (245)	115 (156)	168 (228)	197 (267)
M 20	212 (288)	301 (408)	352 (477)	224 (304)	328 (445)	384 (521)
M24	362 (491)	515 (698)	602 (806)	383 (519)	561 (760)	656 (889)
WHEEL NUTS	65ft lbs (86 Nm)					
SLEW RING BOLTS	218ft lbs (295 Nm)					

This torque chart is based on the following assumptions:

- 1) Bolts to ISO 898-1 "Mechanical properties of fasteners made of carbon steel and alloy steel"
- 2) For "unplated" bolts, all grades:
 - Hex head bolts
 - Black oxide steel bolt with a rolled & oiled thread, no finish on steel nut
 - Prevailing torque includes Nylock (minimum prevailing torque figure assumed)
 - Medium Clearance holes to ISO 273
 - Bolt tightening condition = Yield factor of 75%
- 3) For "plated" bolts, all grades:
 - Hex head bolts
 - Zinc plated oiled (rolled or cut) steel external thread with no finish on steel internal thread
 - Prevailing torque includes Nylock (minimum prevailing torque figure assumed)
 - Medium Clearance holes to ISO 273
 - Bolt tightening condition = Yield factor of 75%

Figures quoted in **Nm** have been calculated in Nm and then rounded to the nearest whole number. Figures quoted in **lb-ft** have been calculated in Nm, converted using a factor of 0.737561 and then rounded.

4 Operation

4.1 CONTROL CIRCUIT COMPONENTS

4.1.1 CONTROL BOARD: - Situated under the canopy, the encapsulated control board comprises of a PCB (printed circuit board) design which incorporates all of the relays to control the machine operation. The control board is common to all models and contains functions which might not be utilised on your machine. A thermal trip switch is integral to the box, which protects the control circuit components. If power is lost, the switch can be manually reset.

4.1.2 TILT ALARM: - Fitted under the canopy, on the power tray at the front of the machine, the tilt alarm is a solid state sensor which monitors the inclination of the machine. The tilt alarm does not operate when the machine is being driven, as the boom switch overrides this function as long as the booms are lowered.

4.1.3 SOUNDER: - Situated beneath the PCB is a small electric sounder, which is used to provide an intermittent alarm whenever the machine is in operation. Pushing a green “power control” button or depressing the foot switch in the basket (if fitted) will energise this sounder. This serves to warn personnel of the operation of the machine.

4.1.4 KLAXON: - Also mounted on the top of the control board box is a klaxon, which performs several functions.-

Firstly, it can be used as a manual alert, by pushing the “Horn” button at the Basket Control Station. Secondly, it is the device which sounds continuously if the tilt alarm sensor detects excessive inclination, with the outriggers incorrectly deployed and the booms raised.

Lastly, it is linked into the battery management system, such that when low battery state is reached the “pulsing” of the DC motors is mimicked by the Klaxon, re-enforcing the message to the operator to re-charge the batteries.

4.1.5 DRIVE CONTROL VALVE (DCV):- The motion control valve comprises of several individual components all directly involved in the hydraulic supply to the wheel drive motors. Principal amongst these are the drive control valves, which electrically change the drive motor hydraulic supply from series flow to parallel, or vice versa. This control function is only available when the booms are lowered and allows the operator to select “Hi” or “Lo” drive. “Hi” drive gives fast speed of travel, but low gradeability, “Lo” drive gives best gradeability, but slow speed. “Lo” drive is used for climbing inclines and delicate positioning of the machine.

4.1.6 BRAKE RELEASE VALVE (BRV):- The motion control valve also incorporates a solenoid operated dump valve which controls the brake function on the machine. This valve must be energised to allow the machine to move. If no voltage is present, the wheel motors will not be able to develop drive torque, whilst at the same time, the spring applied parking brakes will remain engaged. Only when the green “power control” button is being used (or the basket foot switch is depressed) will the BRV operate. If the tilt alarm sensor detects an excessive inclination whilst the booms are raised, it is the BRV which is de-energised to isolate the machine (at the same time the Klaxon tone changes to a continuous one to indicate this condition).

- 4.1.7 BOOM SWITCH:** - Mounted on the boom rest on Boom 1, and operated by the upper boom, this switch controls both the operation of the tilt alarm sensor, and the outrigger interlock. With the booms in the stowed position, the tilt alarm sensor is bypassed, allowing the machine to negotiate slopes in excess of the permissible working angle, without isolating the drive function. At the same time, "Hi" drive is possible, as is fast throttle on those machines so equipped. When the booms are raised, the tilt alarm sensor becomes activated, and the boom switch isolates the outrigger control circuit. These control functions are of primary importance to the safety of the machine and operator; under no circumstances should this control function be isolated or bypassed.
- 4.1.8 BATTERY MANAGEMENT:** - Battery condition is permanently monitored by the control circuit, such that when available power has decreased to 20% of full charge, the battery status circuit begins to "chop" the power to the hydraulic power packs. This function causes the drive system to alternately stop and start, signalling to the operator that re-charging is necessary. At the same time the Klaxon will begin to sound intermittently re-enforcing the charge warning. At this point, sufficient power remains to drive to the nearest power point. Should the operator ignore the on-set of the discharge warning, the "chopping" will continue until the machine is rendered inoperative. Immediate charging will then be required.
- Under no circumstances should a machine be left fully discharged or severe battery damage can occur in a relatively short time.
- 4.1.9 BATTERY ISOLATOR:** - A battery disconnect switch is located next to the engine ignition switch in the right hand canopy, which allows the machine control and power circuits to be isolated from the batteries themselves. Under normal operation, the machine key switch should be used to isolate the machine, with the Battery Isolator only being required for emergencies to disconnect the batteries in the event of a short circuit. The battery charging circuit is connected directly to the battery side, so charging is unaffected by use of this switch.
- 4.1.10 DUTY SELECTOR:** - On multiple power option machines, one of the functions on the Basket Control Station will be a Duty Selector. This key switch allows the selection of either power option i.e. from Diesel to Battery, or Gasoline to Battery, or vice versa. On other machines this same key switch serves as an "ON-OFF" control.
- 4.1.11 DIESEL ENGINE:**-Generally a Kubota D722-E engine, described in the maintenance section of the Workshop Manual, driving a twin bodied pump with direct mounted pump dump valves (one per section). The arrangement allows two speed operation and fast throttle.
- 4.1.12 DIESEL BOX:** -Located adjacent to the Diesel engine, the Diesel box combines all of the functions for Dual power operation, (Bi-Energy machines), as well as controlling the Diesel engine itself. The relays in this box control Starting, High Throttle, Pump Dump, Duty Selector and Diesel Stop Timer. There is also an integral Thermal trip, which protects the Throttle solenoid and other functions.
- 4.1.13 GASOLINE ENGINE:**-Generally a Honda engine, described in the maintenance section of the Workshop Manual, driving a single body pump with direct mounted pump dump valve. The engine is also equipped with a throttle solenoid for two speed operation.

Operating & Safety Instructions

- 4.1.14 GASOLINE BOX:-** Located adjacent to the gasoline engine, the Gasoline Box combines all of the functions for dual power operation, as well as controlling the gasoline engine itself. The relays in this box control Starting, High Throttle, Pump Dump, Duty Selector and Engine Stop. There is also an integral Thermal trip, which protects the Throttle solenoid and other functions.
- 4.1.15 LPG OPERATION:-** On machines equipped for LPG operation (propane) the Honda engine will also have an LPG vaporiser, valve lock and micro-vac switch. The supply and regulation of the propane is governed by the installed gas bottle and regulator. The vapour take-off system requires a vaporiser to convert the liquid gas into an airborne mixture. This is then held by the micro-vac switch and valve lock until the engine turns over, creating a vacuum on the inlet to the engine carburettor. The micro-vac switch then tells the valve lock to open, admitting the gas to the engine. If the engine is halted, the system returns to normal, holding the gas until a re-start is attempted. When running on Gasoline, the main tap to the gas bottle should be securely closed, to prevent the engine from trying to run on a mixture of the two fuels. If starting to run on LPG, it should be ensured that all gasoline is discharged from the carburettor bowl before changing to LPG, since the engine will not run satisfactorily if any gasoline is in the carburettor bowl.
- 4.1.16 SPEED CONTROL:** A two position selector allows high throttle for the engine to be selected, or twin power pack operation for fast speed duty. This will operate when the booms are lowered, to allow fast set-up of the outriggers, and fast drive speed.
- 4.1.17 4WD:** This variation is four wheel drive and front wheel steer. Braking is hydrostatic on all wheels and with fail-safe hydraulic parking brakes on the rear wheels. Speed control is fully proportional with hi/lo throttle control and series/parallel or parallel/parallel switching of the drive motors (Tortoise/Hare).

4.2 SETTING UP PROCEDURES

FAILURE TO DEPLOY THE OUTRIGGERS CORRECTLY COULD RESULT IN DEATH OR SERIOUS INJURY.



ALL MODELS

- 1) Read and fully comply with all safety precautions and operating instructions in the Operating and Safety manual and the warning decals on the machine.
- 2) Position Niftylift on firm ground, bearing in mind range of boom movement so that any overhead obstructions or possible hazards such as, but not limited to, power cables, telephone lines, drains, manhole covers, etc. can be safely avoided
- 3) If the load bearing capacity of the ground is in any doubt the machine must **NOT** be used.
- 4) Levelling the machine using the hydraulic outriggers can accommodate a slope of up to 12 degrees, if necessary using suitable load bearing pads to support the downhill jacks. Do not elevate the platform unless the base can be corrected to within 0.5 degrees of level.
- 5) Release boom travelling clamp. (If applicable)
- 7) Check all red emergency stops are not engaged i.e. fully out.
- 8) Ensure selector valve adjacent to drive/outrigger control station is turned fully down to outrigger/drive position. (For four wheel drive machine grasp and hold duty selector. Power will be available automatically).
- 9) From the basket control station depress and hold the green power button or footswitch to give hydraulic power to the outriggers and select the appropriate control lever. Note: No power will be available if the booms are not stowed onto the boom rest.
- 10) Using the four outrigger control levers, lower each outrigger onto a firm, level surface and level machine base ensuring each outrigger foot is taking equal weight with the wheels clear off the ground.
- 11) Check machine is level using spirit level on the base, visible from the basket.
- 12) Change selector valve at drive/outrigger control station to basket, i.e. turn fully up. (On four wheel drive machines, releasing the duty selector handle automatically returns the machine to "basket" operation).
- 13) The booms can now be operated from the ground or basket control station by depressing and holding the green power button. Note: If no power is available check each outrigger is lowered and each footpad is taking equal weight.
- 14) Always lower booms fully before adjusting, raising, retracting or moving the outriggers in any way.
- 15) Never alter, modify or block any of the safety circuits on the Niftylift.

Operating & Safety Instructions

4.3 GROUND CONTROL OPERATION

ALWAYS ALLOW THE ENGINE TO WARM UP BEFORE OPERATING.



4.3.1 GROUND CONTROL INSTRUCTIONS

ALL MODELS

- 1) Ensure all red emergency stops are out.
- 2) Turn key switch at ground control station to ground (i.e. fully down).
- 3) Ensure selector hand valve (if applicable) is turned to basket position (i.e. fully up).
- 4) Battery electric models go to step 11.

DIESEL ENGINE OR BI-ENERGY MODELS

- 5) For a cold engine start, go to step 6) or for a warm engine go to step 7).
- 6) **COLD ENGINE:** - turn the main engine ignition switch (located beneath the front cover) through "ON" to "GL". This engages the glow plug pre-heat system. Hold for 3-5 seconds then turn key fully to "ST" (start) position and the engine will fire.
- 7) **WARM ENGINE:** - turn the main engine ignition switch (located beneath the front cover) through "ON" to "ST" (start) position and the engine will fire.

Note – Unless the diesel engine is running, the SD50 will automatically default to the primary power source (usually battery).

GASOLINE (GASOLINE) ENGINE OR GASOLINE (GASOLINE)/ELECTRIC MODELS

- 8) For a cold engine start, go to step 9) or for a warm engine go to step 10).
- 9) **COLD ENGINE:** - turn the engine fuel tap on and engage the choke lever. Turn the main engine ignition through "ON" to "ST" (Start) and the engine will fire. Return the choke lever to its normal running position after the engine is started.
- 10) **WARM ENGINE:** - turn the engine fuel tap on and turn the main engine ignition through "ON" to "ST" (start) position and the engine will fire.

Note – Unless the diesel engine is running, the SD50 will automatically default to the primary power source (usually battery).

ALL MODELS

- 11) Push and hold green power button.
- 12) Select function and operate hand levers in full accordance with manufacturers Operating and Safety manual. Note: all outriggers must be down before booms can be operated.
- 13) To return control to basket turn key fully clockwise to up position.
- 14) When not in use return machine to stowed position, fully raise and stow all outriggers, turn the key to the centre off position, remove key and chock wheels.

EMERGENCY PROCEDURES

- 1) Push in red emergency stop to shut down all functions.
- 2) Use manual hand pump to manoeuvre machine into a safe place. Base or basket controls can be used whilst the hand pump is being operated. Only when the machine is fully stowed should the flow be directed to the outrigger controls in order to recover the outriggers. Failure to follow this procedure could result in serious injury or risk of death.

4.3.2 BOOM FUNCTIONS

- A) Push and hold green power button.

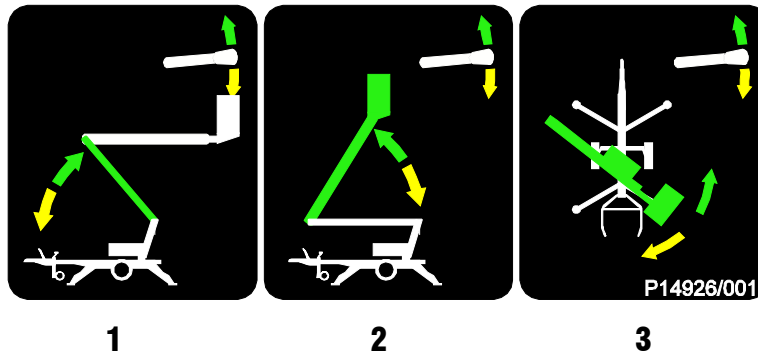

- B) Select lever 1, 2, or 3 for desired boom function.

1 Operates Lower Boom	UP for up	DOWN for down
2 Operates Upper Boom	UP for up	DOWN for down
3 Operates Swing	UP for right	DOWN for left



ALWAYS ENSURE THE AERIAL BASKET IS ON A FIRM SURFACE AND THE AREA IS FREE OF ANY OVERHEAD OBSTRUCTIONS.

ENGAGING THE RED EMERGENCY STOP BUTTON WILL SHUT DOWN THE ENGINE, AND THE ELECTRIC CIRCUIT PREVENTING OPERATION OF ANY FUNCTION.

4.4 BASKET CONTROL OPERATION



NEVER START THE NIFTYLIFT IF YOU SMELL GASOLINE, LIQUID PROPANE OR DIESEL. THESE FUELS ARE FLAMMABLE.

BEFORE OPERATING THE NIFTYLIFT ENSURE THAT EACH OPERATOR HAS READ AND FULLY UNDERSTOOD THE OPERATING MANUAL. FAILURE TO DO SO MAY RESULT IN DEATH OR SERIOUS INJURY.

4.4.1 BASKET CONTROL INSTRUCTIONS

ALL MODELS

- 1) Ensure all red emergency stops are out.
- 2) Turn key switch at ground control station fully up to basket position.
- 3) Ensure selector hand valve (if applicable) is turned to basket position, i.e. fully up.
- 4) Turn selector switch on basket control box to **I** (anti-clockwise) for **battery** operation or **II** (clockwise) for **engine** operation.
- 5) Battery electric models go to step 12).

DIESEL ENGINE OR BI ENERGY MODELS ONLY

- 6) For a cold engine start go to step 7) or for a warm engine start go to step 8).
- 7) **COLD ENGINE:** - turn the engine ignition switch (on the basket control box) to the Glow position (anti-clockwise). This engages the glow plug pre-heat system. Hold for 3-5 seconds then turn the switch to the Start position (fully clockwise) and the engine will fire.
- 8) **WARM ENGINE:** - - turn the main engine ignition switch (on the basket control box) to the Start position (clockwise) and the engine will fire.

GASOLINE ENGINE OR GASOLINE/ELECTRIC MODELS ONLY

- 9) For a cold engine start go to step 10) or for a warm engine start go to step 11).
- 10) **COLD ENGINE:** - (From the ground only) turn the engine fuel tap on and engage the choke lever. Turn the main engine ignition through ON to ST (Start) and the engine will fire. Return the choke lever to its normal running position after the engine is started.
- 11) **WARM ENGINE:** - Ensure the main engine ignition switch is ON. Turn the 3 position engine ignition switch to the right and the engine will fire. When released, the selector will return to the centre, 'OFF' position.

ALL MODELS

- 12) Depress foot switch or push and hold green power button.
- 13) Select function and operate hand levers in full accordance with manufacturers Operating and Safety manual.
- 14) When not in use return booms to stowed position. Fully raise and stow all outriggers. Turn key switch at ground control to centre off position, remove key and chock wheels.

4.4.2 BASKET PUSH-BUTTON CONTROLS STATION

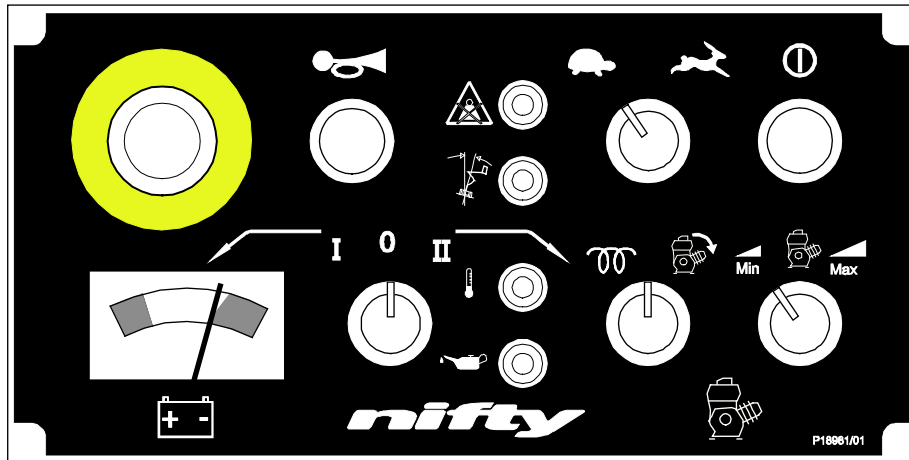

(BI-ENERGY MODEL SHOWN)

4.4.3 DRIVE AND OUTRIGGER FUNCTIONS

Situated at the top of Boom 1 (superstructure) is the 4 lever drive/outrigger hand valve. These control the following functions:

Control the jack deployment as indicated on the label below. (Mounted adjacent to the jack control position).

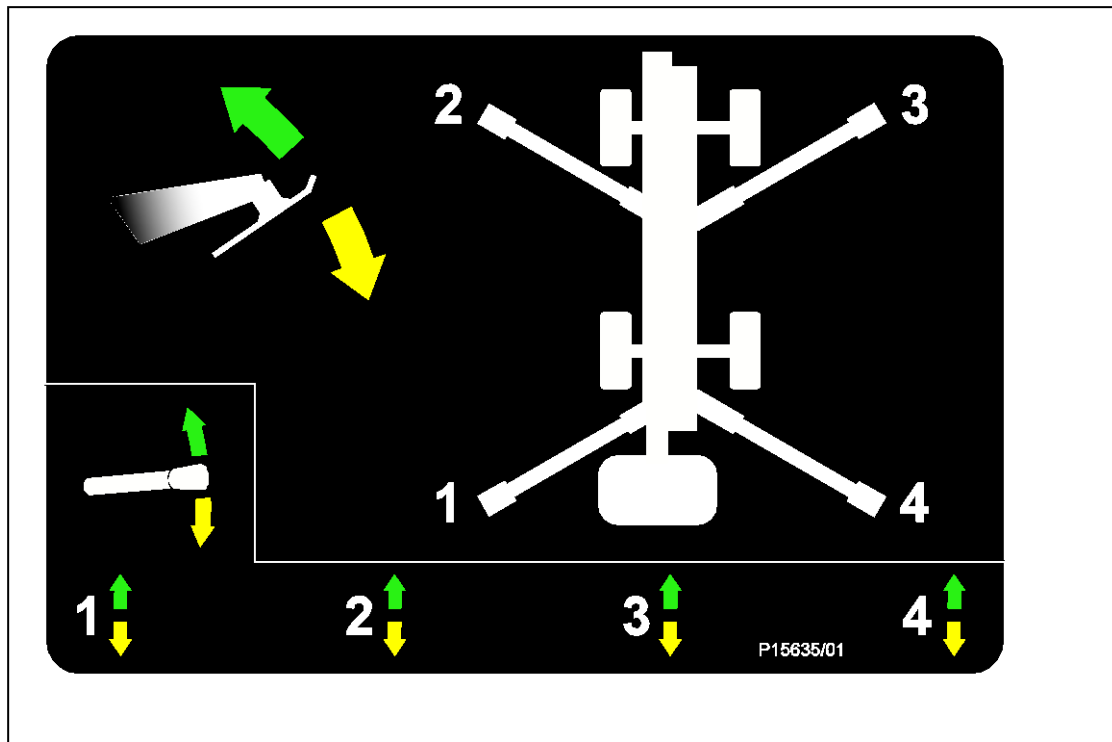

Operating & Safety Instructions

4.4.4 BOOM CONTROLS

- 1) Never exceed the maximum basket capacity of 500lb.
- 2) Check below, above and around the basket for any obstruction or hazards before operating any function.
- 3) Depress foot switch or push and hold green power button.

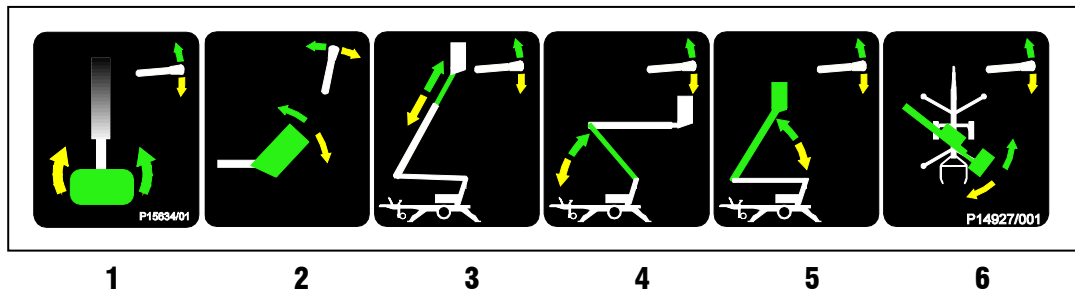

- 4) Select lever **1, 2, 3, 4, 5** or **6** for desired boom function.

1 Operates Basket Swivel (optional)	UP for right	DOWN for left
2 Operates Basket Levelling	FORWARD for forward	BACK for back
3 Operates Telescope	UP for telescope out	DOWN for telescope in
4 Operates Lower Boom	UP for up	DOWN for down
5 Operates Upper Boom	UP for up	DOWN for down
6 Operates Swing	UP for right	DOWN for left



IF ALARM SOUNDS - DESCEND IMMEDIATELY

THIS MACHINE IS NOT ELECTRICALLY INSULATED. DO NOT WORK WITHIN 10FT OF OVERHEAD CABLES EXCEEDING 415 VOLTS

4.5 DRIVING CONTROLS



DO NOT OPERATE THE NIFTYLIFT WHILST ELEVATED UNLESS ON A FIRM, LEVEL SURFACE FREE FROM ANY POSSIBLE OBSTRUCTIONS OR HAZARDS BOTH AT GROUND LEVEL AND OVERHEAD.

- 1) Check proposed route for possible hazards, obstructions and personnel.
- 2) Depress foot switch located in basket floor (if applicable).
- 3) Use the **Drive Speed** selector on the basket control station to determine speed.

High Drive (Hare) - GIVES HIGH SPEED AND LOW GRADEABILITY.

Low Drive (Tortoise) - GIVES LOW SPEED AND HIGH GRADEABILITY.

- 4) Select drive joystick from hand lever controls (left hand lever of five, situated at the drive/outrigger control position).
 - A. Up for **FORWARD**
 - B. Down for **REVERSE**
 - C. Left for **STEER LEFT**
 - D. Right for **STEER RIGHT**
- 5) All control levers give a fully proportional response therefore the more the lever is moved away from the centre (OFF) position the faster the function will become.
- 6) Maximum drive speed is only attainable when all booms are fully stowed and the **HI/LO** selector is in the **HI** position.
- 7) When driving with the booms fully stowed, the Tilt Alarm is bypassed to allow the Niftylift to be driven in areas where the slope exceeds the five degree working limit. In normal operation the drive is therefore unaffected when driven onto a slope in excess of five degrees, until the outriggers are lowered and the booms are raised, whereupon the drive would be disabled and the tilt alarm sounds continuously.
- 8) Under no circumstances should any Niftylift SD series machine be driven on slopes exceeding 30%, with the booms fully stowed.

4.6 BATTERIES AND CHARGING



BATTERIES MUST BE RECHARGED IN A WELL-VENTILATED AREA FREE OF FLAME, SPARKS OR OTHER HAZARDS THAT MAY CAUSE EXPLOSION. HIGHLY EXPLOSIVE HYDROGEN GAS IS PRODUCED DURING THE CHARGING PROCESS.

- 1) Recharge batteries at the end of every working day or shift.
(Note: To recharge batteries fully from flat takes approx. 12 Hours, this consists of 8 hours bulk charging plus 4 hours equalisation).
- 2) Plug charger into suitable power supply, either 240 volts or 110 volts AC (see **Charging Limitations**). (Note: If using 240V, use of a suitably rated Earth Leakage Circuit Breaker (ELCB) or Residual Current Device (RCD) at the point of supply is highly recommended.)

Press **green power button** briefly to energise a motor contactor. This activates the Control Battery Regulator allowing it to charge the 12v engine battery at the same time as the main batteries.

- 3) Take note of the indicators provided:

BC Charger

Red Light - Batteries are charging.

Pulsing Green light - the charge is equalising.

Constant Green light and pulsing Red light - the batteries are fully charged.

GPD Charger

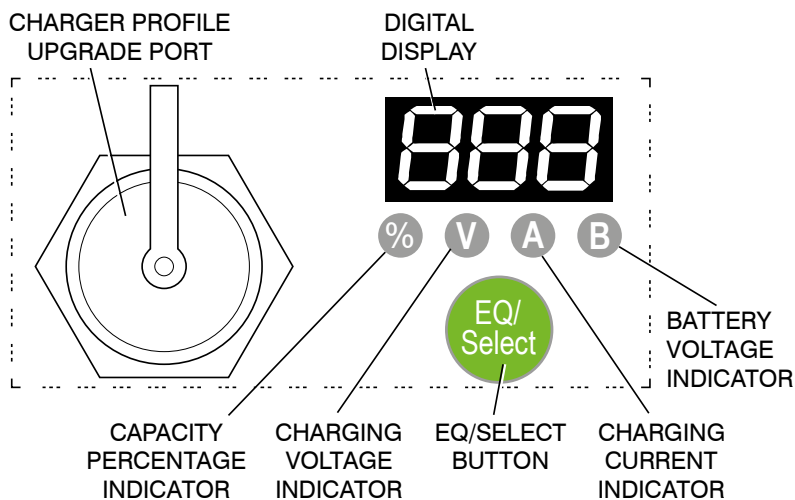

UNDER NO CIRCUMSTANCES SHOULD BATTERIES BE LEFT ON CHARGE FOR PERIODS IN EXCESS OF 24 HOURS

- 4) **DISCONNECT FROM POWER SUPPLY ONCE BATTERIES ARE FULLY CHARGED.** The machine can now be left unattended, however, in the event of the machine being left unused for extensive periods then a **4 to 6 hour** 'top-up' charge every **4 weeks** is recommended. A 'top-up' charge the day before use ensures a full day of operation from the machine.



UNDER NO CIRCUMSTANCES SHOULD A MACHINE BE LEFT FULLY DISCHARGED AS SEVERE BATTERY DAMAGE CAN OCCUR IN A RELATIVELY SHORT TIME.

- 5) To avoid damage to charger disconnect from mains supply before using machine.

Note:

- 1) **BC Charger ONLY;** If the charger is reconnected to the power supply shortly after it has gone through its full charging cycle the Red LED may come on although the batteries may be fully charged. The charger would then go through its complete cycle again at an accelerated rate, depending on the time difference between connection, reconnection and level of battery charge.
- 2) Some machines are fitted with a Battery Management System, which permanently monitors the condition of the batteries. When the batteries become discharged to 20% of their capacity the management system will begin to "shut down" the hydraulic power packs. This causes the drive/boom operating system to alternately stop and start, signalling to the operator that re-charging is necessary. However, there is sufficient power remaining to enable the operator to drive slowly to the nearest charging point.

Should the operator ignore the onset of the battery discharge warning the "shut down" of the motors will continue, until the machine is rendered in-operative. **Immediate charging will then be required.**

CHARGING LIMITATIONS

Battery charging times will increase slightly if using an 110V supply as opposed to a 240V supply. This is due to the connection of the primary coils being in parallel, which in effect only allows the transformer to see 220V. Similarly, the capacity of the 110V supply will decide the input current available; hence a small hand-tool transformer will not operate the battery charger efficiently, therefore: - charging times will increase further due to input limitations.

Fault Conditions (GPD charger ONLY)

If a fault occurs, take note of the digital display and refer to table:

Error code	Cause	Solution
E01 bAt	Poor battery connection, reverse connection or damaged battery	Check battery connection is correct. Check charger connection is correct. Check condition of each battery.
E02 AC	Abnormal AC power input	Check AC input cord is connected between charger and AC outlet. Ensure AC plug is tightly inserted into AC outlet.

Operating & Safety Instructions

E03 Hot	Charger High temperature. Charger shut down due to high internal temperature	Place the charger in a well-ventilated environment. Disconnect the charger and wait for 15-20 mins before reconnecting for charging.
E04 bAt	Battery High temperature. Charger may shut down or reduce current to prevent battery overheating.	When the battery temperature drops, the charger will restart automatically.
E05 Err	Charger Internal Fault	Return to service department if fault persists.
E06 bAt	Battery voltage too high	Check and ensure that the correct output battery voltage is connected.

Attention should also be given to the use of extension cables as power leads. Excessive cable lengths from the supply point to the battery charger will result in significant voltage drop, leading to a reduction in the chargers efficiency. In addition, inadequate sized cable cores will have a limiting effect on its current carrying capacity, which will again lead to a reduction in the chargers efficiency. Both of these can result in over-heating of the cable with the attendant risk of fire, short circuits or damage to the components themselves.

The charger requires a minimum battery voltage of 4.5 volts per battery (overall for two batteries 9 volts, for 4 batteries 19 volts for 8 batteries 38 volts). If the voltage is below these values then the charger will not function (Charger will not detect batteries to begin charge.) If the batteries have fallen to such a poor state they will have to be removed from the machine and charged individually with an independent charger until the optimum voltage has been reached. This is best performed at very low currents to 'recover' the batteries if sulphation has already started i.e. a 'trickle' charger. This can take several hours, possibly days. Careful monitoring of the rise of battery voltage will indicate when recovery has been achieved.

TOPPING UP

During the course of normal operation, the batteries should be inspected at least once a fortnight to check the level of electrolyte. During the end of charge, gassing takes place, which will cause a slight reduction in the volume of acid in the battery. This can be topped up with de-ionised water as required. During this inspection, it is useful to note any imbalance in the fluid levels. One indication of a faulty cell would be an increase in the loss of battery acid, which would then require more frequent topping up on that cell, or cells. Faulty cells can liberate excess hydrogen, even during normal operation, with the resulting risk of explosion if ignited. **Any faulty batteries should be replaced as soon as possible with an equivalent sized and rated unit.**

Note: BATTERIES CONTAIN ACID, therefore: - protective safety glasses and gloves (Appropriate PPE) MUST be worn whilst performing these checks.

4.7 TRANSPORTING, TOWING, CRANEAGE, STORAGE AND SETTING TO WORK

4.7.1 TRANSPORTING

If a work platform is to be moved over a longer distance, whether the machine is trailer mounted, vehicle mounted, self propelled or tracked, the following procedure should be read before restraints are attached to the machine. Cross loading is most frequently the cause of problems, as the method of loading is no longer in sight of our own personnel. The recommendations made herein should be passed on to subsequent carriers, such that the entire journey is carried out without incident.

- Always ensure the truck or trailer you are loading or towing the Niftylift with can carry it legally.
- If loading by crane the use of shackles and an adequately rated spreader beam, with four leg slings, is **MANDATORY**.
- When loading or un-loading from the side of the vehicle, the use of the forklift pockets to retain one of the forks is recommended. (If fitted). Spread the forks to their widest capacity, with due regard to the components fitted to the machine. Never forklift or crane an entire machine under the booms, always lift beneath the spine or under the ends of the axle mountings in the case of a self-propelled unit. Ensure forklift is adequately rated for the load to be carried.
- Once positioned on the transport carrier ratchet straps should be used to secure the machine. The machine should be positioned to allow easy access around the machine in transit, and to ensure that 'creepage' during transport does not permit the machine to come into contact with other goods being shipped, or the container itself. Some movement of the machine structure might occur during transit, which could lead to fretting or other damage.
- If the machine is equipped with a transit device such as a boom clamp etc, this should be securely applied.
- Strap booms carefully to constrain them from sideways movement. When using straps or chains, adequate packing should be applied to stop any damage to the structure and paintwork. Due regard of the movement of the straps or chains must be taken into account.
- Where a machine has designated points for strapping, lifting or forking, these can be used for tie-down duty. When they are absent, the major structure of the basket can be used, giving due consideration to the design and function of the area chosen. Where possible, use the spine of the machine or axle mounts over which to apply the holding down forces. Using a single plate, such as an outrigger or stabiliser support plate might be unsuitable. If the component was clearly not designed to accommodate a side load, one should not be applied.
- Under no circumstances should straps or chains be applied over booms or through the basket support structure or the basket itself. The relative strength of the carrying structure is not conducive to the massive forces capable of being applied through ratchet chains or slings. Severe damage to the steelwork can be caused, as well as deformation to sensitive mechanisms such as basket weigh assemblies, which would render them useless. Such catastrophic damage to say, an electronic load cell would require the component to be replaced before the machine would function.

4.7.2 TOWING - Gearbox drive motors with integral hydrostatic brakes

Towing the Niftylift in case of an emergency.

- 1) If parked on a slope securely chock all wheels.
- 2) Remove front cover: locate brake release valve (red, square knob) and turn **anti-clockwise**. The wheel motors are now free of the hydraulic circuit.
- 3) Move the brake override lever (adjacent to the ground controls), to the **horizontal** position. Fit the manual hand pump handle and give the hand pump several pumps until pressure is felt to build.
- 4) The Niftylift can now be towed over short distances - **maximum speed 5mph**.
- 5) To re-set the brakes, move the brake override lever back to the normal 'up-right' position. Note; It may be necessary to cycle the lever more than once to re-set the brakes.
- 6) In order to drive the machine once more, the brake release valve will need to be closed, by turning **clockwise**. The wheel motors are now re-connected to the hydraulic circuit.
- 7) If the brake override lever is not re-set manually, the next time the machine is moved hydraulically, the brakes will automatically re-set themselves. The brake override lever will however be in the wrong position for emergency operation of the booms, and should be returned to the normal 'up-right' position as soon as possible.

4.7.3 CRANEAGE

- 1) Observe all of the limitations relating to straps and chains stated above under 'Transporting'. (Section 4.7.1)
- 2) When utilising the designated lifting points never apply a 'snatch' load, i.e. lift slowly to take up the load before raising. Similarly, do not drop machine when positioning after lifting.
- 3) If the machine is to be lifted by crane, use the designated lifting points and observe the recommendations regarding spreader beams. Individual drawings are available for each machine type, on request. (See list below.)

D80891

SD50

4.7.4 STORAGE

If being stored for any length of time without use, then the machine should be thoroughly inspected for the following:-

- 1) Grease all bearings /slides, worm drives, etc.
- 2) Check batteries for electrolyte levels, state of charge, damage, dirt, etc. Never leave in a state of discharge for any length of time. If no use of the basket is intended, an occasional "top-up" charge of the batteries will serve to equalise their charge level.
- 3) Leave battery disconnect switch in OFF position to prevent discharge of batteries through leakage.
- 4) If machine is to be left on an incline, chock wheels to prevent creep.

- 5) If machine is to be left out-of-doors or in a hostile environment, cover with suitable weatherproof media to prevent deterioration.

4.7.5 SETTING TO WORK

Before use each day and at the beginning of each shift the machine shall be given a visual and functional test including, but not limited to, the following

- 1) Check all lubrication points for adequate application of grease, oil etc.
- 2) Inspect all threads for ease of operation - especially descent valves, brake release valve etc.
- 3) Check level and quantity of oil. Remove any contaminants - water, etc.
- 4) Check batteries for electrolyte and state of charge.
- 5) Check electrics for damage and insulation.
- 6) Using base controls, cycle machine over complete envelope in accordance with the Operating Instructions. Cure any defects.
- 7) Ensure that all safety devices and controls operate in accordance with the instructions.
- 8) If necessary, perform a load test to establish the machine stability before putting the machine to work.
- 9) On completion of an extended period of road transport, the machine might need additional inspection to identify any transit degradation, which could render the machine unsafe. Perform a P.D.I. inspection on the unit before it enters service. Record any faults found and rectify them immediately.
- 10) If left un-attended for an extended period, it is likely that the hydraulic basket levelling will become un-pressurised. Normal operation is then lost, with a noticeable delay in the forwards or backwards motion as the booms move. To restore normal function, the basket needs to be fully levelled forwards and backwards, using the basket-levelling lever whilst not standing in the basket (i.e. with the operator standing adjacent to the basket side whilst simultaneously operating the lever and green button to move the basket). Take care not to become trapped between the moving basket and a fixed object, and ensure those around you are clear of the moving basket. When the system has been charged in both directions, the basket levelling function should be restored. If the system operates but is 'jerky' in either direction, this indicates air in the system. Repeat the procedure as described above until the movements are smooth and un-interrupted. If in doubt, contact our Service Department for further advice.

Niftylift Limited is not liable for any third party damage caused during transport. Careful attention to correct procedures will prevent many of the small snags that can happen in transit. Re-work is both expensive and time consuming. A defective machine arriving at the place of work is a poor advertisement for our product, the company's reputation and those of our dealers and clients. The responsibility for safe and damage-free transport rests with the haulier or his representatives.

5 Emergency Controls

5.1 GENERAL

CHECKING THE OPERATION OF THE EMERGENCY CONTROLS EVERY DAY AND/OR BEFORE EACH SHIFT IS AN ESSENTIAL PART OF THE OPERATOR'S DUTIES



The operator and all ground personnel must be thoroughly familiar with the location and operation of the EMERGENCY CONTROLS.

5.2 IN THE EVENT OF AN INCAPACITATED OPERATOR

Turn the key switch selector at ground control station to ground (i.e. fully down). Lower on ground controls as detailed under section 4.3 Ground control operation.

5.3 IN THE EVENT OF MACHINE FAILURE

Operate manual hand pump (located adjacent to the base controls) and lower basket to the ground using either basket or base controls. If initial movement of the machine allows the master alarm to reset, normal controls will be available. This is then the fastest method of lowering the basket to the ground.

Note: If the machine is fitted with a basket overload system, and the basket comes into contact with a fixed object whilst operating at height, this would be detected as an overload condition. All power to the machine controls would be lost, requiring the machine to be recovered using the **Manual Hand Pump**. It is sufficient for the basket to be manoeuvred away from the collision point to release the basket weigh system, thereby restoring normal machine operation. The basket could then be brought down using the controls as described previously.



FOLLOWING AN EMERGENCY DESCENT RECOVERY OF THE BASKET, FULLY EXTEND AND RETRACT ALL CYLINDERS FROM GROUND CONTROL STATION BEFORE USING THE MACHINE.

5.4 INCIDENT NOTIFICATION

It is a mandatory requirement that any accident or incident involving a Niftylift, regardless of whether any party received injury or property was damaged, be reported by telephone directly to Niftylift. Failure to do so may render any warranty on the machine void.

6 Responsibilities

6.1 CHANGES IN OWNERSHIP

When a change of ownership of a Niftylift occurs, it shall be the responsibility of the seller to notify Niftylift direct of the unit, model and serial number and the name and address of the new owner within 60 days. This important step is required so that all future Technical Bulletins are able to reach the registered owner of each machine without delay. Please note warranties are not transferable.

6.2 MANUAL OF RESPONSIBILITIES

You are required by ANSI/SAIA A92.20-2018, to read and understand your responsibilities before you use or operate this aerial basket.

Please read the enclosed document, as failure to do so could result in death or serious injury.

Wherever any contradiction may appear, the Manual of Responsibilities shall take precedence over all other documents.

Operating & Safety Instructions

6.3 INSPECTION/SERVICE/PRE-HIRE CHECK LIST

MACHINE SERIAL NO _____

TOWING	PASS	FAIL	N/A
Machine secured on trailer			
Straps correctly positioned and tightened			
Wheels chocked if necessary			
AXLES, WHEELS AND BRAKES			
Wheels are secure, tyre condition acceptable			
Wheel bearings O.K.			
Brake linkages and cables secure			
Brake shoe wear not excessive			
Machine climbs slope			
Brakes hold machine on slope			
Rear hub nut secure			
Track rod secure, not fouling axle plate			
BASE			
Operation of base control valve and buttons			
Operation of all booms over full range			
Cylinders are silent			
Basket is level over full range			
Booms, levelling rods not damaged or distorted			
Booms levelling rods, cylinders not fouling			
Hoses not tight, kinked or fouled			
Operation of manual hand pump			
BOOM ROTATION			
Boom rotation assembly and motor are secure			
Worm/wheel mesh correct, no excessive wear			
No end float of worm in housing			
Boom rotation gear wheel bolts secure			
Boom rotation gear guards secure			
BASKET			
Operation of control valve and buttons			
Levelling lock valve holds in both directions, lines vented			
Operation of all booms over full range			
Cylinders are silent			
Basket levelling over full range			
Boom rotation smooth over full range			
Operation of boom 4 over full range (if fitted)			
No excessive movement of boom 4 and boom 3			

Operating & Safety Instructions

TILT ALARM	PASS	FAIL	N/A
Booms raised on slope - drive disabled, siren tone constant			
Boom operation unaffected			
Booms lowered - drive restored			
INTERNAL (POWER PACK)			
Power pack and all components secure			
All cables and terminals secure			
All hose connections secure			
Hoses not kinked or fouled			
Charger/control box secure			
Batteries secure			
Electrolyte level and specific gravity			
Charger operation			
Hydraulic oil level			
Engine/Gear box oil			
FINISH			
Pivot pin tag bolts			
Correct decals, all visible			
Canopy/bonnets			
Grease nipples (Feet, Knuckle, Centre Post)			
LEAK CHECK			
Cylinders (Lift, Outriggers, Telescope, Levelling)			
Control valves			
Check valves			
Power pack/pump			
Boom rotation motor			
Hose connections			
Filter			
Wheel motors			

Comments, remedial work required etc;

INSPECTED BY: _____

DATE: / /

niftylift