

nifty

SP64

Operating & Safety Instructions

MODEL SP64 SERIES
(4x4)

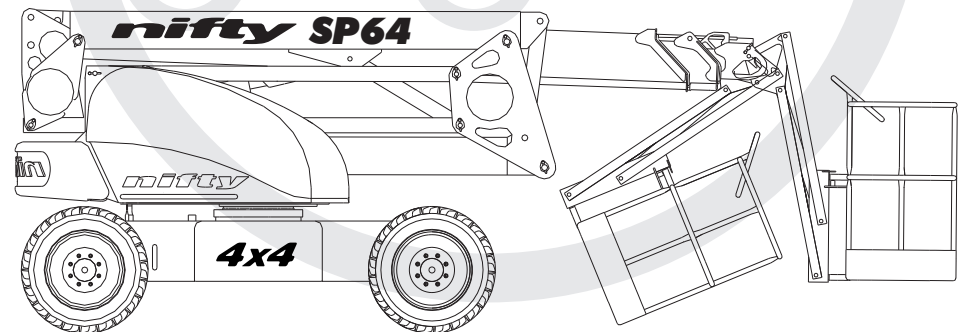

niftylift.com
info@niftylift.com

M50408/03



Niftylift Limited
1525 S. Buncombe Road
Greer
SC 29651
USA

www.niftylift.com
e-mail: niftyusa@niftylift.com
Tel: 864-968-8881
Fax: 864-968-8836

Table of Contents

1	INTRODUCTION AND GENERAL INFORMATION	PAGE
1.1	Foreword	2
1.2	Severity of Hazards	2
1.3	Scope	3
1.4	Introducing the Self Propelled (SP) Series	3
1.5	General Specification	4
1.6	Identification	5
1.7	EC Declaration of Conformity (Typical)	6
2	SAFETY	
2.1	Mandatory Precautions	7-9
2.2	Environmental Limitations	10
2.3	Noise & Vibration	10
2.4	Test Report	11
3	PREPARATION AND INSPECTION	
3.1	Unpacking	12
3.2	Preparation for Use	12
3.3	Pre-Operational Safety Check Schedules	13-15
3.4	Placard, Decals and Installation	16-17
3.5	Torque Requirements	18
4	OPERATION	
4.1	Control Circuit Components	19-20
4.2	Ground Control Operation	21-22
4.3	Basket Control Operation	23-25
4.4	Driving Controls	26
4.5	Basket Weigh System (If Fitted)	27
4.6	Transporting, Craneage, Storage and Setting to Work	28-30
5	EMERGENCY CONTROLS	
5.1	General	31
5.2	Emergency Procedures - Incapacitated Operator	31
5.3	Emergency Procedures - Niftylift Failure	31
5.4	Boom Controls	32
5.5	Towing	33-34
5.6	Incident Notification	34
6	RESPONSIBILITIES	
6.1	Changes in Ownership	34
6.2	Manual of Responsibilities (USA only)	34
6.3	Inspection/ Service Check List	35-36

1 Introduction and General Information

1.1 FOREWORD

The purpose of this manual is to provide the customer with safety, operating and maintenance instructions essential for proper Niftylift operation.

This manual should be READ and fully UNDERSTOOD before any attempt is made to operate the Niftylift!

Niftylift has no direct control over the Niftylift's application and use, therefore conformance with good safety practices is the responsibility of the user and his operating personnel.

These manuals are very important tools - Keep them with the Niftylift at all times.

All information in these manuals is based on the use of the Niftylift under proper operating conditions.

Alteration and/or modification of the Niftylift are STRICTLY FORBIDDEN.

Remember: Any equipment is only as safe as those who operate it!

1.2 SEVERITY OF HAZARDS

The use of this type of equipment presents certain dangers to the operator which are clearly identified both in this manual and on the Niftylift. The varying levels of risk are defined as follows:

DANGER

If not correctly followed there is a high probability of serious injury or death to personnel.

WARNING or CAUTION

If not correctly followed there is some possibility of serious injury or death to personnel.

The 'Safety Alert Symbol' is used to call attention to potential hazards which may lead to serious injury or death, if ignored.



IMPORTANT and INSTRUCTIONS

This denotes procedures essential to safe operation and prevention of damage to, or destruction of the Niftylift.

NOTICE

This indicates general safety rules and/or procedures relating to the Niftylift.

It is the owner's/user's responsibility to know and comply with all applicable rules, regulations, laws, codes and any other requirements applicable to the safe use of this equipment.

1.3 SCOPE

These operating instructions contain all the necessary information required to allow the safe operation of any Niftylift SP64, with a diesel (D) engine.

For further technical information, circuit diagrams and specific instructions for all maintenance which may need to be carried out by specialist trained personnel, see the associated Workshop and Parts manual for your model of Niftylift Height Rider.

1.4 INTRODUCING THE SP SELF-PROPELLED SERIES

Please note at the time of going to press all information, illustrations, details and descriptions contained herein are valid. Niftylift reserves the right to change, modify or improve its products without any obligations to install them on previously manufactured Niftylifts.

If, after reading this manual you require further information, please do not hesitate to contact us.

Niftylift Inc, 1525 S. Buncombe Road, Greer, SC 29651 USA

Tel: **864 968 8881** Fax: **864 968 8836** Email: **niftyusa@niftylift.com**

Driven from the basket, the Niftylift SP64 is an extremely versatile articulated boom platform of unique and simple design. It is capable of placing two men and their tools up to a height of 67ft 9in or an outreach of 41ft 4in.

The compact narrow base and tight turning circle, combined with powered boom rotation, up and over capability, good outreach, combined with sensitive controls, ensure excellent manoeuvrability and maximum efficiency.

High traction tires and powerful hydraulic wheel motors give unsurpassed performance with the option of fast drive speed when the booms are in the stowed position. Automatic braking and audible alarms activated by a five-degree tilt sensor help to prevent the operator from working on unsafe terrain whilst elevated.

The Niftylift SP64 provides a fast, safe, cost effective method of access, both inside and out, for a multitude of applications where overhead working is required.

Models include the following:

D: - DIESEL

Operating & Safety Instructions**1.5 GENERAL SPECIFICATION**

FEATURE	SP64
MAXIMUM HEIGHT - WORKING	67ft 9in
MAXIMUM HEIGHT - PLATFORM	61ft 4in
MAXIMUM OUTREACH	41ft 4in
MAXIMUM HEIGHT – STOWED	7ft
MAXIMUM WIDTH	7ft 5in
MAXIMUM LENGTH – STOWED	16ft 5in
PLATFORM CAPACITY - Europe	500lbs
WHEELBASE	7ft 6in
TURNING RADIUS – OUTSIDE	13ft
TURRET ROTATION	355°
TURRET TAIL SWING	1ft 7in
TRAVEL SPEED	0-4.1mph
PLATFORM SIZE	5ft 11in x 2ft 2in
CONTROLS	Proportional electric over hydraulic
HYDRAULIC PRESSURE	2900psi
TIRES	Solid
GRADE-ABILITY	45%
MINIMUM VEHICLE WEIGHT	13,700lb
MAXIMUM GROUND PRESSURE	21,951lb/ft ²
POWER SOURCE	D (Diesel) models - Kubota 1505 (4x4)

1.6 IDENTIFICATION (USA PLATE)

	
NIFTYLIFT LTD. RINGLE DRIVE, STONEBRIDGE MILTON KEYNES MK13 0ER GREAT BRITAIN TEL (01144) 1908 223456 : FAX (01144) 1908 312733 e-mail : info@niftylift.com	
THIS WORK PLATFORM COMPLIES WITH ANSI STANDARD A 92-	
MODEL	
SERIAL NO	
YEAR OF MANUFACTURE	
CAPACITY RATING	LBS
PLATFORM HEIGHT	FEET
GROSS WEIGHT	LBS
MAXIMUM HYDRAULIC PRESSURE	PSI
MAXIMUM VOLTAGE	V
AMPS	A
ELEC. CCT D	ISSUE
HYD. CCT D	ISSUE
P11497	

This manufacturer's plate is attached to Boom 1 on each Niftylift at the time of manufacture on every Niftylift. Please ensure all sections have been stamped and are legible.

1.7 EC DECLARATION OF CONFORMITY (Typical)



EC DECLARATION OF CONFORMITY

MANUFACTURER AND PERSON RESPONSIBLE FOR DOCUMENTATION: **NIFTYLIFT LTD
MALCOLM NORTH**

ADDRESS: **FINGLE DRIVE,
STONEBRIDGE,
MILTON KEYNES,
MK13 0ER,
ENGLAND.**

MACHINE TYPE: **MOBILE ELEVATING WORK PLATFORM**

MODEL TYPE:

SERIAL NUMBER:

NOTIFIED BODY: **RWTUV Anlagentechnik GmbH**

NOTIFIED BODY NUMBER: **0044**

ADDRESS: **POSTFACH 10 32 61
D-45141 ESSEN
GERMANY**

CERTIFICATE NUMBER:

APPLICABLE STANDARDS: **EN 280:2001+A2:2009
DIN EN 60204-1, 2006/42/EC**

We hereby declare that the above mentioned machine conforms with the requirements of the Machinery Directive, 2006/42/EC and EMC Directive 2004/108/EC

SIGNED:  DATE: 14th December 2009

NAME: Malcolm North POSITION: Engineering Manager

NOTE:
THIS DECLARATION CONFORMS WITH THE REQUIREMENTS OF ANNEX II-1.A OF THE COUNCIL DIRECTIVE 2006/42/EC. ANY MODIFICATIONS TO THE ABOVE MENTIONED MACHINE WILL INVALIDATE THIS DECLARATION, AND THE MACHINE'S APPROVAL.

2 Safety

2.1 MANDATORY PRECAUTIONS

When operating your Niftylift, your safety is of utmost concern. In order to fully appreciate all aspects of the Niftylifts operation it should be ensured that each operator has **READ** and fully **UNDERSTOOD** the relevant manual covering Niftylift use, maintenance and servicing. If any doubts exist concerning any points covered in your manual, contact your local dealer or Niftylift Ltd.

Before using any Niftylift, thoroughly inspect the Niftylift for damage or deformation to all major components. Likewise, check the control systems for hydraulic leaks, damaged hoses, cable faults or loose covers to electrical components. At no time should damaged or faulty equipment be used - Correct all defects before putting the platform to work. If in doubt, contact your local dealer or Niftylift Ltd (see front cover for address).



THE MANUFACTURER HAS NO DIRECT CONTROL OVER THE NIFTYLIFT APPLICATION AND USE. THEREFORE CONFORMANCE WITH GOOD SAFETY PRACTICES IS THE RESPONSIBILITY OF THE USER AND HIS OPERATING PERSONNEL. FAILURE TO UNDERSTAND AND FOLLOW ALL SAFETY RULES COULD RESULT IN SERIOUS INJURY OR DEATH.

- 2.1.1** Only trained persons will be permitted to operate the Niftylift.
- 2.1.2** Always operate the Niftylift in full accordance with the manufacturers Operating & Safety Instructions for that model.
- 2.1.3** Before use each day and at the beginning of each shift the Niftylift shall be given a visual inspection and functional test including, but not limited to, operating and emergency controls, safety devices, personal protective clothing, including fall protection, air, hydraulic and fuel system leaks, cables and wiring harness, loose or missing parts, tires and wheels, placards, warnings, control markings and Operating and Safety Manuals, guards and guard rail systems and all other items specified by the manufacturer.
- 2.1.4** Any problems or malfunctions that affect operational safety must be repaired prior to use of the platform, with specific regard to any safety components refer to the Parts Manual for part numbers and details. If in doubt, contact Niftylift Ltd (Details on page 3). **Ensure wheels are chocked before carrying out any maintenance that involves a bypass of parking brakes as described in Section 5.6.**
- 2.1.5** Always ensure that all warning labels, instructions, placards, control markings and Safety Manuals are intact and clearly legible. If replacements are required contact your local dealer or Niftylift. Always observe and obey safety and operating instructions on such labels.
- 2.1.6** Do not alter, modify or disable in any way the controls, safety devices, interlocks or any other part of the Niftylift.
- 2.1.7** Before the Niftylift is used and during use the user shall check the area in which it is to be used for possible hazards such as, but not limited to, uneven ground drop-offs, holes, bumps, obstructions, debris, floor and overhead obstructions, high voltage conductors, wind and weather, unauthorised persons and any other possibly hazardous conditions.
- 2.1.8** Never exceed the maximum basket capacity, as indicated on the decals and Niftylift serial plate.
- 2.1.9** Only operate the Niftylift on a firm, level surface.

Operating & Safety Instructions

2.1.10 Never position any part of the Niftylift within the Minimum Approach Distances of any electrical power line, conductor, or similar stated in Occupational Safety and Health Administration Regulations for CFR 1910.333(c) for Minimum Approach Distance for electrical wires.

1910.333(c)(3)(i)(A)(1): For voltages to ground **50kV or below** - 10 feet (305 cm);

1910.333(c)(3)(i)(A)(2): For voltages to ground **over 50kV** - 10 feet (305 cm) plus 4 inches (10 cm) for every 10kV over 50kV.



THIS NIFTYLIFT IS NOT INSULATED.

If in doubt, contact the appropriate authorities

2.1.11 On entering the basket ensure that the drop down entry bar is closed afterwards.

2.1.12 Use of an approved safety belt and lanyard, hard hat and appropriate safety clothing is mandatory. Fasten harness to designated harness securing points within the platform and do not remove until leaving the platform whilst in the stowed position.

2.1.13 Always remain standing within the basket. Do not attempt to increase your height or reach by standing and/or climbing on the basket guard rails or any other object. **KEEP YOUR FEET ON THE BASKET FLOOR.** Do not sit, stand or climb on the guard rail, mid rail or boom linkage. Use of planks, ladders or any other devices on the Niftylift for achieving additional height or reach shall be prohibited.



2.1.14 Do not use the basket levelling system to artificially increase the outreach of the Niftylift. Never use boards or ladders in the basket to achieve the same result.

2.1.15 Do not use the basket to lift overhanging or bulky items that may exceed the maximum capacity or carry objects that may increase the wind loading on the basket. (e.g. Notice boards etc.)

2.1.16 The Niftylift shall not be operated from a position on trucks, trailers, railway cars, floating vessels, scaffolds or similar equipment unless the application is approved in writing by Niftylift Ltd in Great Britain.

2.1.17 Always check that the area below and around the platform is clear of personnel and obstructions before lowering or rotating the booms. Care should be taken when rotating the booms out into areas where there may be passing traffic. Use barriers to control traffic flow or prevent access to the Niftylift.

2.1.18 Stunt driving and horseplay, on or around the Niftylift, shall not be permitted.

2.1.19 When other moving equipment and vehicles are present, special precautions shall be taken to comply with local ordinances or safety standards established for the work place. Warnings such as, but not limited to, flags, roped off areas, flashing lights and barricades shall be used.

2.1.20 Before and during driving while the basket is elevated the operator shall maintain a clear view of the path of travel, maintain a safe distance from obstacles, debris, drop offs, holes, depressions, ramps and other hazards to ensure safe elevated travel. Maintain a safe distance from overhead obstacles.

2.1.21 Under all travel conditions the operator shall limit travel speed according to conditions of ground surface, congestion, visibility, slope, location of personnel and other factors causing hazards of collision or injury to personnel.

2.1.22 The Niftylift shall not be driven on grades, side slopes or ramps exceeding those for which the aerial platform is rated by the manufacturer.

- 2.1.23** It shall be the responsibility of the user to determine the hazard classification of any particular atmosphere or location. Aerial platforms operated in hazardous locations shall be approved and suitable for the duty. (See ANSI/NFPA 505-1987 where applicable).
- 2.1.24** The operator shall immediately report to his supervisor any potentially hazardous location(s) (environment) which become evident during operation.
- 2.1.25** If an operator encounters any suspected malfunction of the Niftylift or any hazard or potentially unsafe condition relating to capacity, intended use or safe operation, he shall cease operation of the Niftylift and request further information as to safe operation from his management, or owner, dealer or manufacturer before further operation of the Niftylift.
- 2.1.26** The operator shall immediately report to his superior any problems or malfunctions of the Niftylift, which becomes evident during operation. Any problems or malfunctions that affect the safety of operation shall be repaired prior to continued use.
- 2.1.27** The boom and basket of the Niftylift shall not be used to jack the wheels off the ground.
- 2.1.28** The Niftylift shall not be used as a crane.
- 2.1.29** The Niftylift shall not be positioned against another object to steady the platform.
- 2.1.30** Care should be taken to prevent rope, electric cords and hoses from becoming entangled in the aerial platform.
- 2.1.31** Batteries shall be recharged in a well-ventilated area free of flame, sparks or other hazards, which may cause explosion. Highly explosive hydrogen gas is produced during the charging process.
- 2.1.32** When checking electrolyte levels great care should be taken to protect eyes, skin and clothing. Battery acid is highly corrosive and protective glasses and clothing is recommended.
- 2.1.33** If the basket or elevating assembly becomes caught, snagged or otherwise prevented from normal motion by adjacent structure or other obstacles, such that control reversal does not free the Niftylift, all personnel shall be removed from the basket safely before attempts are made to free the Niftylift using ground controls.

2.1.34

When the Niftylift is not in use always stow the booms correctly. **NEVER LEAVE THE KEYS IN THE NIFTYLIFT**, if it is to be left for any period of time. Use wheel chocks if leaving on an incline.

2.1.35

The engine must be shut down while fuel tanks are being filled. Fuelling must be done in a well-ventilated area free of flame, sparks or any other hazard that may cause fire or explosion. **GASOLINE, LIQUID PROPANE AND DIESEL FUELS ARE FLAMMABLE.**

2.1.36

NEVER START THE NIFTYLIFT IF YOU SMELL GASOLINE, LIQUID PROPANE OR DIESEL FUEL. THESE FUELS ARE HIGHLY FLAMMABLE

2.1.37

The operator shall implement means provided to protect against use by unauthorised persons.

2.1.38

Never remove anything that may affect the stability of the Niftylift such as, but not limited to, batteries, covers, engines, tires or ballast.

2.2 ENVIRONMENTAL LIMITATIONS

Unless specifically configured otherwise, the Niftylift will have a short operational time in extreme temperatures such as freezers and cold storage, due to reduced battery performance. For electrical cables and components, the temperature must be within the range -5°C to 60°C.

The Niftylift is limited in high temperatures because of the cooling requirement for engines and hydraulic oil. Coolant temperatures must be within the range -37°C to 110°C (at 50% mixture of water to anti-freeze). Oil temperature not to exceed -23°C to 93°C.

The recommended operational range for these Niftylifts is - 5°C to +40°C. Please contact Niftylift Ltd for special considerations if the Niftylift is required to operate outside these temperatures.

Extended operation in dusty environments is not recommended, frequent cleaning will be necessary. All dust, dirt, salt encrustation, excess oil or grease should be removed. Deposits of paint or bitumen, particularly on legends or labels should be removed.

All standard Niftylifts are rated for a wind speed of 28mph or force 6 on the Beaufort scale. No attempt should be made to operate a Niftylift in wind strengths above this limit and if the operator has any doubts over the wind speed he / she should cease operation immediately until it can be established that the wind speed has fallen to a safe level.



DO NOT USE THE NIFTYLIFT IN ELECTRICAL STORMS

2.3 NOISE AND VIBRATION

The airborne noise emission on the Height Rider range of Niftylift's does not exceed 79dB(A), measured at a perpendicular distance of 13ft, under equivalent continuous A-weighted sound pressure test conditions. This was based on a Diesel powered Niftylift, working on high throttle, and under load. All other models will exhibit significantly lower emissions than this figure, dependant on power option. In normal operation the Vibration level to which the operator is subjected will not exceed a weighted root mean square acceleration value of 2.5 m/s².

2.4 TEST REPORT

All Niftylift models are subjected to a comprehensive 'type test' which duplicates all combinations of safe working load (SWL), overload, windage, inertia and pull force to assess the various safe stability criteria. Self propelled Niftylifts are also subjected to kerb and braking tests at the SWL to satisfy additional 'worse case' stability requirements.

Each individual Niftylift is then subjected to static overload tests on flat level ground with 150% of the SWL, exceeding the requirements of EN280 for power operated MEWPs. Self propelled Niftylifts are also tested at the maximum working angle **plus** 0.5° with a test load of 125% of the SWL. Finally, on all Niftylifts, a functional test is performed with 110% of SWL.

All safety devices are checked for correct operation, operating speeds are checked against benchmark figures and the dynamic functions ensure that all acceleration and deceleration forces are within acceptable limits. All noted defects are rectified and recorded before the Niftylift is permitted to enter into service.

3 Preparation and Inspection

3.1 UNPACKING

Since the manufacturer has no direct control over the shipping or carriage of any Niftylift it is the responsibility of the dealer and/or owner and/or lessee to ensure the Niftylift has not been damaged in transit and a Pre-operational Report has been carried out by a qualified engineer before the aerial platform is put into service.

- A) Remove all ropes, straps and or chains used to secure the aerial platform during transit.
- B) Ensure any ramp, loading dock or forklift used is capable of supporting or lifting the Niftylift.
- C) If the Niftylift is to be driven off, please ensure that the operator has read and fully understood this entire manual. Refer to the appropriate section for precise operating instructions.

*****Carry out the Pre-operational Report before placing Niftylift in service.**

3.2 PREPARATION FOR USE

Whilst every effort has been made at the Niftylift factory to ensure your Niftylift arrives in a safe and operable condition it is necessary to carry out a systematic inspection prior to putting the aerial platform into service.



THIS IS NOT A REQUEST IT IS MANDATORY

To assist the user in this task you will find enclosed a Pre-operational Report, which must be filled out upon delivery/receipt of the Niftylift.

Before the user carries out the Pre-operational Report he must have read and fully understood all the contents of the Operating, Safety and Maintenance Manual.



WARNING - DO NOT OPERATE A POTENTIALLY DEFECTIVE OR MALFUNCTIONING NIFTYLIFT. CORRECT AND REPAIR ANY DEFECTS BEFORE OPERATING YOUR NIFTYLIFT.

3.3 PRE-OPERATIONAL SAFETY CHECK SCHEDULES

Before use each day and at the beginning of each shift the aerial platform shall be given a visual inspection and functional test including, but not limited to, the following:

3.3.1 DAILY SAFETY CHECKS

- 1) Check that all labels (decals) are in place and legible.
- 2) Visually inspect the Niftylift for damaged or loose components.
- 3) Check the fuel level (if applicable).
- 4) Check that canopies/covers and guards are in place and secure.
- 5) Check that the boom rest switch is operable (if applicable).
- 6) Check that control levers are secure and operate freely.
- 7) Check that operating buttons and emergency stop buttons function properly.
- 8) Check the operation of the manual hand pump.
- 9) Visually inspect all hydraulic hoses and fittings for damage or leaks.
- 10) Check that the basket pivot pins and their tag bolts are secure.
- 11) Check that the tilt alarm is functioning properly (On a slope of 5° or more the alarm should sound and drive should be disabled).
- 12) Check the operation of SiOPS (Refer to Section 4.3.3).
- 13) Check the operation of the basket weigh system (If fitted). See section 4.5.3 for testing and verification procedure.

3.3.2 WEEKLY SAFETY CHECKS

- 1) Inspect tires and wheels for damage and wear.
- 2) Check that the joystick is secure.
- 3) Check battery fluid levels and specific gravity (after charging) and general condition.
- 4) Check hydraulic oil level, Grade 32.
- 5) Inspect the engine air filter and clean or replace if necessary.
- 6) Inspect hose track for damage or missing parts.

Operating & Safety Instructions

3.3.3 MONTHLY SAFETY CHECKS

- 1) Check the engine oil level (if applicable).
- 2) Check the wheel nuts (torque 110ft lbs / 150Nm).
- 3) Check that the bolts holding the wheel motors to the chassis are secure.
- 4) Check that the boom rotation gear worm is secured and correctly in mesh. Clean and re-grease.
- 6) Inspect the engine fuel tank for damage or leaks.
- 7) Check telescopic boom wear pads and nylon studs (if applicable).
- 8) Check and adjust if necessary the Nylatron studs around the telescope boom.
- 9) **If fitted**, every **three** months check and verify the calibration of the basket weigh system. See section 4.5.4 for the calibration procedure.
- 10) Every **Six** months perform a **thorough examination** in accordance with the 'Lifting Operation and Lifting Equipment Regulations' (LOLER) 1998, Regulation (9)(3)(a).

3.3.4 ANNUAL SAFETY CHECKS

- 1) Check that all pivot pins and their tag bolts are secure.
- 2) Inspect for any cracks or badly rusted areas on booms and chassis.
- 3) Change the hydraulic oil filters.
- 4) Check the bushes in the front wheel hubs for wear.
- 5) Check that boom rotation gear ring bolts are secure (torque 220ft lbs. 300Nm).

Toughcage

Niftylift **toughcage** is fully UV stabilised for outdoor use in the most demanding climates. However, the user and Niftylift owner should consider the following;

- Discolouration of the material may occur; this is a natural aging process which does not significantly alter the material properties.
- Degredation to the floor may occur as a consequence of product use and effect of UV exposure. The **toughcage** multi-layer construction means degradation of the top surface may occur over time without compromising the structural strength of the internal and base layers.
- The rate at which the **toughcage** floor ages is dependent upon the Niftylifts application and its country of use (Typical levels of UV exposure). Refer to table below for aging rate applicable to your specific area.

UK, NETHERLANDS, GERMANY, POLAND, SCANDINAVIA, CANADA, RUSSIA	14 years
FRANCE, ITALY, USA (NORTH EAST STATES)	11 years

SPAIN, GREECE, TURKEY, CHINA, USA (MID WEST STATES), AUSTRALIA (TASMANIA)	9.5 years
MALAYSIA, INDONESIA	8 years
USA (SOUTH STATES), SOUTH AMERICA, AUSTRALIA (VICTORIA, NEW SOUTH WALES)	7.5 years
USA (WEST STATES), SOUTH AFRICA, INDIA, PAKISTAN, IRAN, AUSTRALIA (WESTERN, SOUTH, QUEENSLAND)	7 years
NORTH AFRICA, SAUDI, DUBAI, AUSTRALIA (NORTHERN TERRITORY)	6 years

Note: The date of manufacture of the **tough** cage floor is located on its underside.

Niftylift recommends that the user and Niftylift owner regularly inspect the tough basket floor for damage. If any significant damage is found then the floor must be replaced. For further guidance please contact Niftylift Limited.

Operating & Safety Instructions**3.4 PLACARD, DECALS & INSTALLATION (USA)**

ITEM	DESCRIPTION	NUMBER	QTY
1	"Niftylift.com"	P14390	1
2	Harness Point	P14883	2
3	Head Protection	P14921	1
4	Danger HR & TM's	P24900	2
5	"If E-Stop Disabled"	P14864	2
6	Hydraulic Oil	P17226	1
7	SWL 500lbs	P17328	1
8	Manual Descent	P23020	1
9	Daily Safety Check List	P14908	1
10	"If Tilt Alarm Sounds"	P14868	2
11	Cage Gate Warning	P18335	1
12	Hand Crush – Pictorial	P14782	11
13	Travel Direction	P14784	1
14	Serial Plate	P15383	1
15	Gearbox Disengage	P19180	4
17	Tie-Down Point	P24025	4
18	Hydraulic Levers - Base	P22042	1
19	Hydraulic Levers – Basket	P14020	1
20	"4x4" Logo	P14697	2
21	"SP64" Logo	P19070	2
22	Battery drain	P19850	1
23	Footswitch	P14884	1
24	No Step	P14785	4
25	General Notice HR's	P18870	1
26	Control Buttons – Basket	P26708	1
28	Diesel	P14414	1
30	Operating Instructions	P14892	1
31	Noise Warning	P17124	1
32	Control Buttons – Base	P22429	1
35	Trip – Push to Reset	P19056	1
36	Point Loading	P15215	4
37	"Raise Flyboom"	P19442	1
38	Emergency Control Location	P22877	1
40	Chain Inspection	P16535	1
41	HR21 Slew Pin	P18587	2
44	Battery Isolator	P18600	1
47	Rotating Machinery	P15010	2
49	Emergency Instructions	P21700	1
50	Hazard tape	N/A	N/A
51	Toughcage	P21816	2

Operating & Safety Instructions**3.5 TORQUE REQUIREMENTS**

BOLT QUALITY/SIZE	Tightening torque in lbs ft (Nm)					
	Plated			Unplated		
Grade	8.8	10.9	12.9	8.8	10.9	12.9
M 6	5 (7)	8 (10)	9 (12)	6 (8)	8 (11)	10 (13)
M 8	13 (17)	18 (25)	22 (29)	14 (19)	20 (27)	23 (32)
M 10	25 (34)	36 (49)	43 (58)	27 (37)	40 (54)	46 (63)
M 12	43 (58)	63 (85)	73 (99)	47 (63)	69 (93)	80 (108)
M 14	68 (93)	100 (135)	117 (158)	74 (101)	109 (148)	127 (172)
M 16	106 (143)	154 (209)	180 (245)	115 (156)	168 (228)	197 (267)
M 20	212 (288)	301 (408)	352 (477)	224 (304)	328 (445)	384 (521)
M24	362 (491)	515 (698)	602 (806)	383 (519)	561 (760)	656 (889)
WHEEL NUTS	110 ft lbs (150 Nm)					
WHEEL GEARBOX NUTS	99 ft lbs (135 Nm)					
SLEW RING BOLTS	220 ft lbs (300 Nm)					

This torque chart is based on the following assumptions:

- 1) Bolts to ISO 898-1 "Mechanical properties of fasteners made of carbon steel and alloy steel"
- 2) For "unplated" bolts, all grades:
 - Hex head bolts
 - Black oxide steel bolt with a rolled & oiled thread, no finish on steel nut
 - Prevailing torque includes Nylock (minimum prevailing torque figure assumed)
 - Medium Clearance holes to ISO 273
 - Bolt tightening condition = Yield factor of 75%
- 3) For "plated" bolts, all grades:
 - Hex head bolts
 - Zinc plated oiled (rolled or cut) steel external thread with no finish on steel internal thread
 - Prevailing torque includes Nylock (minimum prevailing torque figure assumed)
 - Medium Clearance holes to ISO 273
 - Bolt tightening condition = Yield factor of 75%

Figures quoted in **Nm** have been calculated in Nm and then rounded to the nearest whole number. Figures quoted in **lb-ft** have been calculated in Nm, converted using a factor of 0.737561 and then rounded.

4 Operation

4.1 CONTROL CIRCUIT COMPONENTS

4.1.1 MAIN CONTROL BOARD: - Situated under the left-hand superstructure cover, the encapsulated control board comprises a PCB (printed circuit board) design which incorporates all of the relays to control the Niftylift operation. The control boards are common to all models, and contain functions which might not be utilised on your particular Niftylift.

4.1.2 TILT ALARM: - Fitted to the superstructure underneath the base controls cover, a solid state sensor which monitors the inclination of the Niftylift. It directly controls the BRV (Brake Release Valve) and when the platform is in use, i.e. Booms are raised, if the inclination exceeds the pre-set limit, it will disable the drive to the Niftylift and sound the alarm. In order to recover the Niftylift, the basket operation is unaffected, allowing the operator to restore drive when the Niftylift is stowed. It is then possible to drive back onto level ground, fully restoring Niftylift operation.

4.1.3 SOUNDER: - Situated on the side of the base control box is a small piezo electric sounder, which is used to provide an intermittent alarm whenever the Niftylift is in operation. Pushing the green "power control" button, or depressing the foot switch in the basket (if fitted) will energise this sounder. This serves to warn personnel of the operation of the Niftylift.

4.1.4 KLAXON: - Also located on the back of the base control box is a klaxon, which performs several functions:

Firstly, it can be used as a manual alert, by pushing the "Horn" button at the basket control position. Secondly, it is this device which sounds continuously if the Tilt Alarm Sensor detects excessive inclination, with the booms raised. Thirdly this will sound when the low fuel warning light comes on. Lastly, it is linked into the battery management system, such that when low battery state is reached the "pulsing" of the D.C. motors is mimicked by the Klaxon, reinforcing the message to the operator to charge the Niftylift.

4.1.5 DRIVE CONTROL VALVE: - This valve contains the ON/OFF solenoid and PRV for the boom controls. It also contains the steer valve and the brake release system. If any of these functions need to be overridden this can be done by using the hand pump, (see Section 5.3).

4.1.6 SUSPENSION CONTROL VALVE - This valve controls the cylinders on the unique suspension system. This system will only be active when the booms are in the down position and the telescope is retracted.

4.1.7 BOOM-SWITCHES: - Mounted on the tele-knuckle and links knuckle, and operated by any of the booms raising and/or the telescopic boom going out, these switches control both the operation of the Tilt Alarm Sensor, and the speed control function. With the booms in the stowed position, the Tilt Alarm Sensor is by-passed, allowing the Niftylift to negotiate slopes in excess of the permissible working angle, without isolating the drive function. At the same time, High drive (Depicted by a Hare Icon) is possible, as is fast throttle on those Niftylifts so equipped. When the booms are raised or the telescope is out, the Tilt Alarm Sensor becomes activated, only slow speed operation is possible and only Low drive (Depicted by a Tortoise Icon) is permitted. When the booms are raised and the telescope out is engaged the Niftylift goes to a third slower speed. These control functions are of primary importance to safety of the Niftylift and operator, under no circumstances should this control function be isolated or by-passed.

Operating & Safety Instructions

4.1.8 BATTERY MANAGEMENT (ELECTRIC/BI-ENERGY MODELS ONLY): - Battery condition is permanently monitored by the control circuit, such that when available power has decreased to 80% of full charge, the battery status circuit begins to "chop" the power to the hydraulic power packs. This function causes the drive system to alternately stop & start, signalling to the operator that re-charging is necessary. At the same time the Klaxon will begin to sound intermittently reinforcing the charge warning. At this point, sufficient power remains to drive to the nearest power point. Should the operator ignore the on-set of the discharge warning, the "chopping" will continue until the Niftylift is rendered inoperative. Immediate charging will then be required.

Under no circumstances should a Niftylift be left fully discharged or severe battery damage can occur in a relatively short time.

4.1.9 BATTERY ISOLATOR: - A battery disconnect plug is located beneath the base control canopy, which allows the Niftylift control and power circuits to be isolated from the batteries themselves. Under normal operation, the basket Key switch should be used to isolate the Niftylift, with the Battery plug only being required for emergencies to disconnect the batteries in the event of a short circuit, or during servicing of the Niftylift to ensure that the power is disconnected.

On electric and bi-energy Niftylifts, the battery charging circuit is connected directly to the battery side, so charging is un-affected by use of this switch. The main battery pack is grounded to the chassis.

4.1.10 DUTY SELECTOR: - On multiple power option modes, the Niftylift will default to electric power unless the diesel engine has been started.

4.1.11 DIESEL ENGINE: - Generally a Kubota V1505 engine described in the maintenance section of the Workshop Manual, driving swash plate pump with integral relief valve on the main control valve. The arrangement allows two speed operation of all functions.

4.1.12 FUSES AND TRIP SWITCHES: -

- 1) **125A** fuse near the diesel engine battery (starter motor and alternator).
- 2) **10A** circuit breaker (main control system).
- 3) **35A** circuit breaker (heavy duty circuit for diesel throttle/Glow plug).

4.1.13 LOAD SENSING CONSOLE (SIOPS™): - This Niftylift incorporates a load sensing basket console that senses if the operator has been pushed or has fallen against the console. If the load applied to the front of the console is greater than the pre-determined amount, the footswitch will be disabled to increase operator safety and reduce the possibility of sustained involuntary operation of the basket controls. For further information refer to Section 4.3.3.

4.2 GROUND CONTROL OPERATION

4.2.1 GROUND CONTROL FUNCTIONS

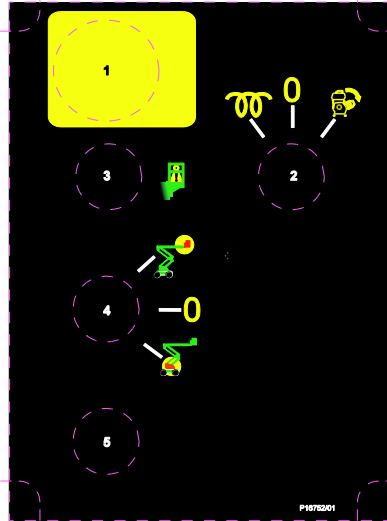

(Base Control Panel)

1 Emergency Stop	Push to Stop Niftylift	Turn clockwise to Release
2 Diesel Glow/Start Selector	Turn Clockwise – Glow, Off and Start positions	
3 Basket Overload Indicator	See Section 4.5	
4 Base/Platform Selector	Up for Basket	Down for Base
5 Green Power Button	Push and hold to activate Niftylift	

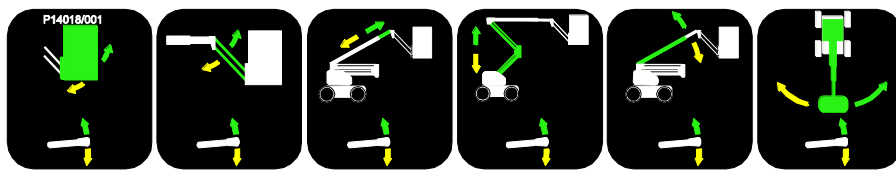

(Base Levers)

1 Operates Platform Levelling	Up for Forward **	Down for Backward **
2 Operates the Flyboom	Up for Up	Down for Down
3 Operates Telescoping	Up for Tele Out	Down for Tele In
4 Operates the Link Booms	Up for Up	Down for Down
5 Operates the Upper Boom	Up for Up	Down for Down
6 Operates Swing	Up for Right	Down for Left

** Basket levelling only active when booms are down

4.2.2 OPERATION

ALWAYS ALLOW THE ENGINE TO WARM UP BEFORE OPERATING.



ALL MODELS

- 1) Ensure all red emergency stops are out.
- 2) Turn **Base/Basket** selector at ground control station to **Ground** (Clockwise).

DIESEL ENGINE

- 3) **COLD ENGINE:** - turn the **Diesel Glow/Start** selector to the **Glow** position (anti-clockwise). This engages the glow plug pre-heat system. Hold for 5-10 seconds then turn the key to the **Start** position (fully clockwise) and the engine will fire.
- 4) **WARM ENGINE:** - turn the **Diesel Glow/Start** selector to the **Start** position (clockwise) and the engine will fire.

ALL MODELS

- 5) Push and hold green power button on the base control box.
- 6) Select a function and operate the appropriate hydraulic lever in full accordance with manufacturers operating and safety manual.
- 7) To return control to the basket turn the **Base/Basket** selector to the **Basket** position (anti-clockwise).
- 8) When not in use return Niftylift to stowed position. **Note:** Fully lower the Link booms first (Lever 4) followed by the Upper boom (Lever 5) for smooth operation. Turn the **Base/Basket** selector to centre **Off** position, remove key and chock wheels.

EMERGENCY PROCEDURES

- 9) Push in red emergency stop to shut down all functions.
- 10) In the event that the controls fail or the operator becomes incapacitated the booms can be operated by using the hand pump which is located under the canopy next to the base controls. To operate:
 - a) Check the selector under the middle bonnet is turned to booms.
 - b) Move and hold lever to be operated.
 - c) Use hand pump lever to move Niftylift.
 - d) Release control lever to halt Niftylift movement

4.3 PLATFORM CONTROL OPERATION

4.3.1 PLATFORM CONTROL FUNCTIONS

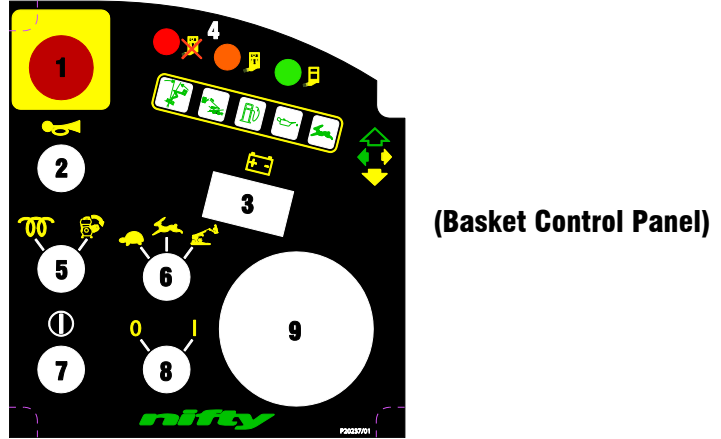

1 Emergency Stop	Push to Stop Niftylift	Turn clockwise to Release
2 Horn	Push to sound	
3 Battery Charge Indicator		
4 Basket Overload Indicators	See Section 4.5	
5 Diesel Glow/Start	Anti-clockwise to Glow Engine, Clockwise to Start Engine	
6 Drive Speed Selector	Turn Clockwise - Slow, Fast and Rough terrain modes	
7 Green Power Button	Push and hold to activate Niftylift	
8 On/Off Selector	Activates Basket Control Panel	
9 Joystick		

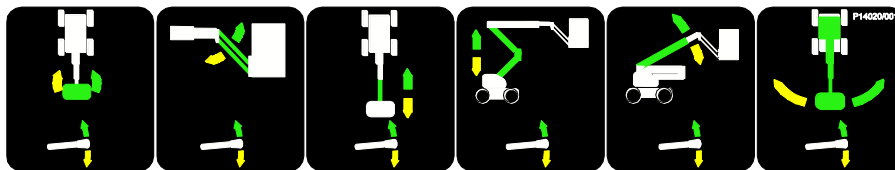

(Basket Levers)

1 Operates Platform Rotation	Up for Clockwise	Right for Anti-Clockwise
2 Operates the Flyboom	Up for Up	Down for Down
3 Operates Telescoping	Up for Tele-In	Down for Tele-Out
4 Operates the Link Booms	Up for Up	Down for Down
5 Operates the Upper Boom	Up for Up	Down for Down
6 Operates Swing	Left for Left	Right for Right

Operating & Safety Instructions

4.3.2 OPERATION



NEVER START THE NIFTYLIFT IF YOU SMELL GASOLINE, LIQUID PROPANE OR DIESEL. THESE FUELS ARE FLAMMABLE.

BEFORE OPERATING THE NIFTYLIFT ENSURE THAT EACH OPERATOR HAS READ AND FULLY UNDERSTOOD THE OPERATING MANUAL. FAILURE TO DO SO MAY RESULT IN DEATH OR SERIOUS INJURY.

ALL MODELS

- 1) Ensure all red emergency stops are out.
- 2) Turn the **Base/Basket** selector at the ground control station to **Basket** (anti-clockwise).

DIESEL ENGINE

- 3) **COLD ENGINE:** - turn the **Diesel Glow** selector left to engage the glow plug pre-heat system and hold for 5-10 seconds, then turn the **Diesel Start** selector to the **Start** position (right) and the engine will fire.
- 4) **WARM ENGINE:** - turn the **Diesel Start** selector to the **Start** position (clockwise) and the engine will fire.

ALL MODELS

- 5) Depress the footswitch (if available) or push and hold green power button on the platform control box.
- 6) Select a function and operate the hydraulic control levers in full accordance with manufacturers operating and safety manual.
- 7) To return control to the base turn **Base/Basket** selector to the **Base** position (clockwise).
- 8) When not in use return Niftylift to stowed position. **Note:** Fully lower the Link booms first (Lever 4) followed by the Upper boom (Lever 5) for smooth operation. Turn the **Base/Basket** selector to centre **Off** position, remove key and chock wheels.



ALWAYS ENSURE THE NIFTYLIFT IS ON A FIRM LEVEL SURFACE AND THE AREA IS FREE OF ANY OVERHEAD OBSTRUCTIONS.

ENGAGING THE RED EMERGENCY STOP BUTTON WILL SHUT DOWN THE ENGINE, AND THE ELECTRIC CIRCUIT PREVENTING OPERATION OF ANY FUNCTION.

4.3.3 SiOPS™ - LOAD SENSING CONSOLE (If fitted)



WHEN OPERATING THIS NIFTYLIFT THE USER MUST BE AWARE OF ANY OVERHEAD OBSTRUCTIONS.

This Niftylift incorporates a load sensing basket console that senses if the operator has been pushed or has fallen against the console. If the load applied to the front of the console is greater than the pre-determined amount, the footswitch will be disabled to increase operator safety and reduce the possibility of sustained involuntary operation of the basket controls.

Note: The green button will illuminate once the footswitch has been disabled, but continues to be available for use at all times. This allows the operator to use the basket control functions and manoeuvre the Niftylift to a safe position.

To reset the footswitch:

- 1) Release the load from the front of the console.
- 2) Ensure basket controls are in the neutral position and clear of objects.
- 3) Raise foot clear of footswitch then lower foot onto footswitch.
- 4) Footswitch is now active and full control has been restored.

Note: If SiOPS™ has been activated and the footswitch is not reset within **15 seconds**, then the blue warning beacon will flash (If fitted, located on underside of the basket) and a warning announcement will sound until the footswitch is reset as described previously.

Operating & Safety Instructions

4.4 DRIVING CONTROLS



DO NOT OPERATE THE NIFTYLIFT WHILST ELEVATED UNLESS ON A FIRM, LEVEL SURFACE FREE FROM ANY POSSIBLE OBSTRUCTIONS OR HAZARDS BOTH AT GROUND LEVEL AND OVERHEAD.

- 1) Check proposed route for possible hazards, obstructions and personnel.
- 2) Depress switch located on the front of the joystick.
- 3) Use the **Drive Speed** selector on the basket control station to determine speed.

Low Drive (Tortoise) - gives low speed and low engine revs..

High Drive (Hare) - gives high speed and high engine revs.

RT Drive (Rough Terrain) - gives low speed and high engine revs.

N.B. High Drive is only available when the booms are in the stowed position. The SP64 will default to Low Drive speed whenever the booms are elevated.

- 4) Select drive joystick from the basket control box.
 - A. Up for **FORWARD**
 - B. Down for **REVERSE**

Steering is controlled by the rocker-switch button on the top of the joystick

C. Left for **STEER LEFT**

D. Right for **STEER RIGHT**

The driving horn is activated by the button on the front of the joystick and there is also a separate horn button on the basket controls for use when the drive and boom controls are switched off.

- 5) All control levers give a fully proportional response therefore the more the lever is moved away from the centre **Off** position the faster the function will become.
- 6) Maximum drive speed is only attainable when all booms are fully stowed and the **Drive Speed** selector is in the **High Drive** (Hare) position.
- 7) When driving with the booms fully stowed, the Tilt Alarm is bypassed to allow the Niftylift to be driven in areas where the slope exceeds the five-degree working limit. In normal operation the drive is therefore unaffected when driven onto a slope in excess of five degrees, until the booms are raised, whereupon the drive would be disabled and the tilt alarm sounds continuously.
- 8) **Under no circumstances** should any **SP64** series Niftylift be driven on slopes exceeding the gradeability in the general specification.



ALL NIFTYLIFTS ARE FITTED WITH A TILT ALARM - PRE-SET IN THE FACTORY. ONCE ENERGISED THE NIFTYLIFT WILL LOSE ALL POWER TO DRIVE FUNCTIONS AND A LOUD AUDIBLE ALARM WILL BE ACTIVATED.

TO DE-ACTIVATE, LOWER THE BOOMS FULLY TO STOWED POSITION AND RE-POSITION BASE ON FIRM, LEVEL GROUND.

IF ALARM SOUNDS - DESCEND IMMEDIATELY AND RE-LEVEL NIFTYLIFT BASE.

4.5 BASKET WEIGH SYSTEM

4.5.1 LOAD CELL VERSION

The Niftylift SP64 is fitted with an electronic load cell. This load cell is a moment-independent, redundant design. This means that independent of the load position inside the basket of the Niftylift, the actual load is measured and if pre-configured limit values are exceeded, warnings will be activated. "Redundant design" means that the load cell design incorporates dual channels that monitor each other. The design of the unit meets the requirements of both EN280 and EN954-1 class III.

4.5.2 FUNCTION

The Niftylift informs the operator, via the load cell output, of the current state of the Niftylift with regard to basket load. There are three output lamps: **green**, **amber** and **red**. The three lamps for the load cell are located on the basket control panel (see section 4.3.1). These lamps can be interpreted as follows:

Lamp	Description	Load value	Niftylift Behaviour
Constant green	Load in the basket does not exceed 80% of safe working load	180kg or less	Normal operation
Constant amber	Load in the basket is 80-90% of safe working load	180kg to 203kg	Normal operation
Flashing amber	Load in the basket is 90% of safe working load	203kg to 225kg	Normal operation
Flashing red (Safety Warning Lamp)	Load in the basket has exceeded safe working load	Above 225kg	Controls isolated – safely remove excess load to restore normal operation

4.5.3 CALIBRATION, INSPECTION AND MAINTENANCE

Calibration, maintenance and repair of the Niftylift SP64 basket load cell require specialist knowledge and equipment. **For this reason, no part of the Niftylift SP64 electronic basket-weigh system can be adjusted, repaired or inspected by the operator.**

All enquiries relating to calibration, inspection or maintenance should be directed to Niftylift or one of Niftylift's approved dealers. Contact details are listed in Section 1.4.

4.6 TRANSPORTING, CRANEAGE, STORAGE AND SETTING TO WORK

4.6.1 TRANSPORTING

If a Niftylift is to be moved over a longer distance, whether the Niftylift is trailer mounted, vehicle mounted, self propelled or tracked, the following procedure should be read before restraints are attached to the Niftylift. Cross loading is most frequently the cause of problems, as the method of loading is no longer in sight of our own personnel. The recommendations made herein should be passed on to subsequent carriers, such that the entire journey is carried out without incident.

- Always ensure the truck or trailer you are loading or towing the Niftylift with can carry it legally.
- If loading by crane the use of shackles and an adequately rated spreader beam, with four leg slings, is **MANDATORY**.
- When loading or un-loading from the side of the vehicle, the use of the forklift pockets to retain one of the forks is recommended. (If fitted). Spread the forks to their widest capacity, with due regard to the components fitted to the Niftylift. Never forklift or crane an entire Niftylift under the booms, always lift beneath the spine or under the ends of the axle mountings in the case of a self-propelled unit. Ensure forklift is adequately rated for the load to be carried.
- Once positioned on the transport carrier ratchet straps should be used to secure the Niftylift. The Niftylift should be positioned to allow easy access around the Niftylift in transit, and to ensure that 'creepage' during transport does not permit the Niftylift to come into contact with other goods being shipped, or the container itself. Some movement of the Niftylift structure might occur during transit, which could lead to fretting or other damage.
- If the Niftylift is equipped with a transit device such as a boom clamp etc, this should be securely applied.
- Strap booms carefully to constrain them from sideways movement. When using straps or chains, adequate packing should be applied to stop any damage to the structure and paintwork. Due regard of the movement of the straps or chains must be taken into account.
- Where a Niftylift has designated points for strapping, lifting or forking, these can be used for tie-down duty. When they are absent, the major structure of the platform can be used, giving due consideration to the design and function of the area chosen. Where possible, use the spine of the Niftylift or axle mounts over which to apply the holding down forces. Using a single plate, such as an outrigger or stabiliser support plate might be unsuitable. If the component was clearly not designed to accommodate a side load, one should not be applied.
- Under no circumstances should straps or chains be applied over booms or through the basket support structure or the basket itself. The relative strength of the carrying structure is not conducive to the massive forces capable of being applied through ratchet chains or slings. Severe damage to the steelwork can be caused, as well as deformation to sensitive mechanisms such as basket weigh assemblies, which would render them useless. Such catastrophic damage to say, an electronic load cell would require the component to be replaced before the Niftylift would function.

Do not tow Niftylift without first following the towing procedure described in Section 5.6 of this manual.



4.6.2 CRANEAGE

- 1) Observe all of the limitations relating to straps and chains stated above under 'Transporting'. (4.6.1)
- 2) When utilising the designated lifting points never apply a 'snatch' load, i.e. lift slowly to take up the load before raising. Similarly, do not drop the Niftylift when positioning after lifting.
- 3) If the Niftylift is to be lifted by crane, use the designated lifting points and observe the recommendations regarding spreader beams. Individual drawings are available for each Niftylift type, on request. (See list below.)

D80938

SP64

4.6.3 STORAGE

If being stored for any length of time without use, then the Niftylift should be thoroughly inspected for the following:-

- 1) Grease all bearings /slides, worm drives, etc.
- 2) If Niftylift is to be left on an incline, chock wheels to prevent creep.
- 3) If Niftylift is to be left outdoors or in a hostile environment, cover with suitable weatherproof media to prevent deterioration.

4.6.4 SETTING TO WORK

If your Niftylift has arrived direct from the factory or via a dealer, then it may safely be put straight to work. However, if the Niftylift has been in storage or if unsure about the Niftylift's recent history then a full safety check should be made:

- 1) Check all lubrication points for adequate application of grease, oil etc.
- 2) Inspect all threads for ease of operation - especially descent valves, brake release valve etc.
- 3) Check level and quantity of oil. Remove any contaminants - water, etc.
- 4) Check battery for electrolyte & state of charge.
- 5) Check electrics for damage & insulation.
- 6) Using base controls, cycle Niftylift over complete envelope in accordance with the Operating Instructions. Cure any defects.
- 7) Ensure that all safety devices and controls operate in accordance with the instructions.
- 8) If necessary, perform a load test to establish the Niftylift stability before putting it to work.
- 9) On completion of an extended period of road transport, the Niftylift might need additional inspection to identify any transit degradation, which could render the Niftylift unsafe. Perform a P.D.I. inspection on the unit before it enters service. Record any faults found and rectify them immediately.
- 10) If left un-attended for an extended period, it is likely that the hydraulic basket levelling will become un-pressurised. Normal operation is then lost, with a noticeable delay in the forwards or backwards motion as the booms move. To restore normal function, the basket needs to be fully levelled forwards and backwards, using the basket-levelling lever at the ground control

Operating & Safety Instructions

station with no load in the basket. Take care not to become trapped between the moving basket and a fixed object, and ensure those around you are clear of the moving basket. When the system has been charged in both directions, the basket levelling function should be restored. If the system operates but is 'jerky' in either direction, this indicates air in the system. Repeat the procedure as described above until the movements are smooth and un-interrupted. If in doubt, contact our Service Department for further advice.

Niftylift Limited is not liable for any third party damage caused during transport. Careful attention to correct procedures will prevent many of the small snags that can happen in transit. Re-work is both expensive and time consuming. A defective Niftylift arriving at the place of work is a poor advertisement for our product, the company's reputation and those of our dealers and clients. The responsibility for safe and damage-free transport rests with the haulier or his representatives.

5 Emergency Controls

5.1 GENERAL

CHECKING THE OPERATION OF THE EMERGENCY CONTROLS EVERY DAY AND/OR BEFORE EACH SHIFT IS AN ESSENTIAL PART OF THE OPERATOR'S DUTIES



The operator and all ground personnel must be thoroughly familiar with the location and operation of the **EMERGENCY CONTROLS**.

5.2 IN THE EVENT OF AN INCAPACITATED OPERATOR

Turn the **Base/Basket** selector at ground control station to **ground** (clockwise). Lower on ground controls as detailed under Section **4.2 Ground Control Operation**.

5.3 IN THE EVENT OF NIFTYLIFT FAILURE

If all Niftylift power is lost, the **Manual Hand pump** can be used to provide the hydraulic power to manoeuvre the Niftylift. Lower basket using hand lever controls at ground control station. If initial movement of the Niftylift allows the master alarm to reset, normal controls will be available. This is then the fastest method of lowering the platform to the ground.

Note: If the Niftylift is fitted with a basket overload system, and the basket comes into contact with a fixed object whilst operating at height, this would be detected as an overload condition. All power to the Niftylift controls would be lost, requiring the Niftylift to be recovered using the **Manual Hand Pump**. It is sufficient for the basket to be manoeuvred away from the collision point to re-set the basket weigh mechanism, thereby restoring normal operation. The basket could then be brought down using the controls as described previously.

Opening the nearside canopy reveals the ground controls, plus the dedicated hydraulics for the Emergency recovery of the Niftylift.



Primarily there are two manual hand pumps, one for the boom functions only, mounted separately and adjacent to the ground control valve block. The second hand pump is specifically for the drive system and is incorporated into the Drive Control Valve.

Operating & Safety Instructions

5.4 BOOM CONTROLS

On opening the canopy cover, the two hand pump handles are revealed. The black handle with a red handgrip fits the Boom hand pump. Remove the handle and fit this to the appropriate pump. When the handle is actuated, hydraulic flow is generated and will be supplied directly to the ground control valve block. Operating the ground control lever will permit the Niftylift to be manoeuvred by the ground personnel.



If desired, the Basket operator can hold the appropriate lever to manoeuvre the Niftylift, whilst a ground operative provides the motive power using the manual hand pump. When not in use, the handle should be stowed back in its clips.

FOLLOWING AN EMERGENCY DESCENT RECOVERY OF THE PLATFORM, FULLY EXTEND AND RETRACT ALL CYLINDERS FROM GROUND CONTROL STATION BEFORE USING THE NIFTYLIFT.



5.5 TOWING

If the Niftylift needs to be towed in case of an emergency, it will be necessary to **chock the wheels** before commencing gearbox disengagement.

5.5.1 IDENTIFYING GEARBOX TYPE

In order to safely tow the SP64, the drive mechanism will need to be bypassed. Identify the type of gearbox fitted to the machine then refer to the relevant procedure for disengagement of the gearboxes.

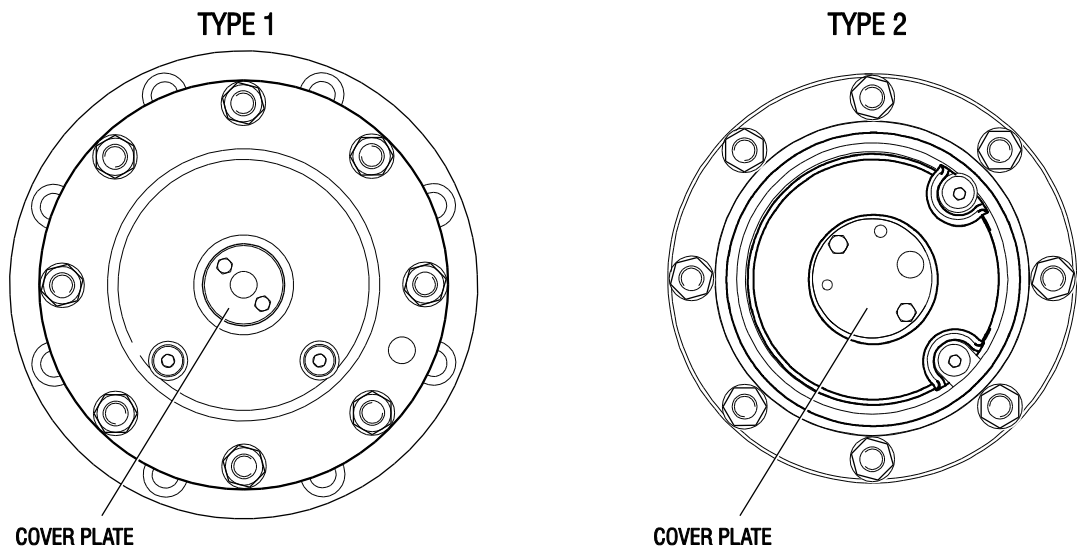

5.5.2 GEARBOX DISENGAGEMENT (TYPE 1)

The drive gearboxes located on the front and rear wheel hubs must be disengaged as follows;

- 1) To disengage the gearbox, remove both screws from the cover plate, turn it upside down (as per the diagram below), re-tighten the M5 screws to a torque of 5 Nm (3.7lbf).
- 2) Before attempting to re-engage the gearbox, ensure that the machine is jacked up so the relevant wheel is clear of the ground in order to prevent damage. **Note; Damage caused by failure to comply with this notice will not be covered by the manufacturer's warranty.**

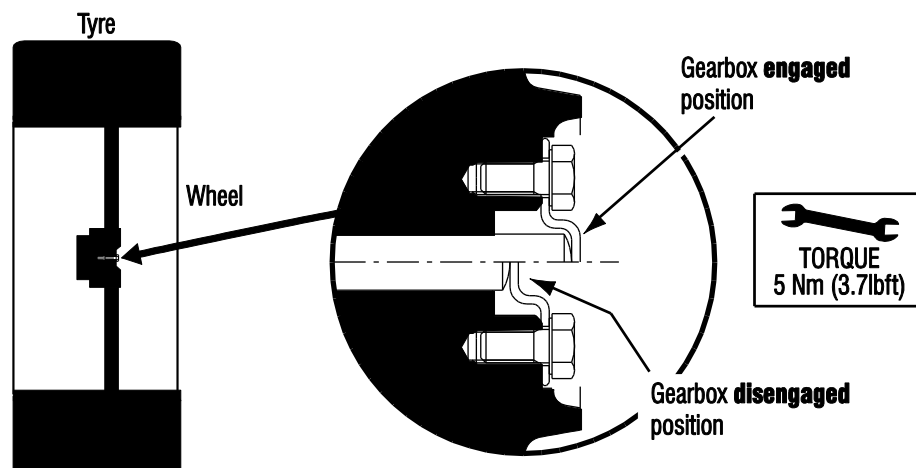

Operating & Safety Instructions

5.5.3 GEARBOX DISENGAGEMENT (TYPE 2)

The drive gearboxes located on the front and rear wheel hubs must be disengaged as follows;

- 1) Remove both retaining bolts that secure the cover disc to the centre of the wheel hub.
- 2) Partially screw one of the retaining bolts into the end of the central disengage pin and pull the pin out fully, ensuring the recess on the pin is visible.
- 3) Place the cover disc over the pin, ensuring the retaining disc is engaged in the pin recess and secure in place using the remaining retaining bolt.
- 4) To re-engage the gearbox, complete the above instructions in reverse order, ensuring gearbox drive is free to engage before pushing the pin 'home'. If necessary, jack up each wheel & rotate slightly to allow re-engagement of pin.

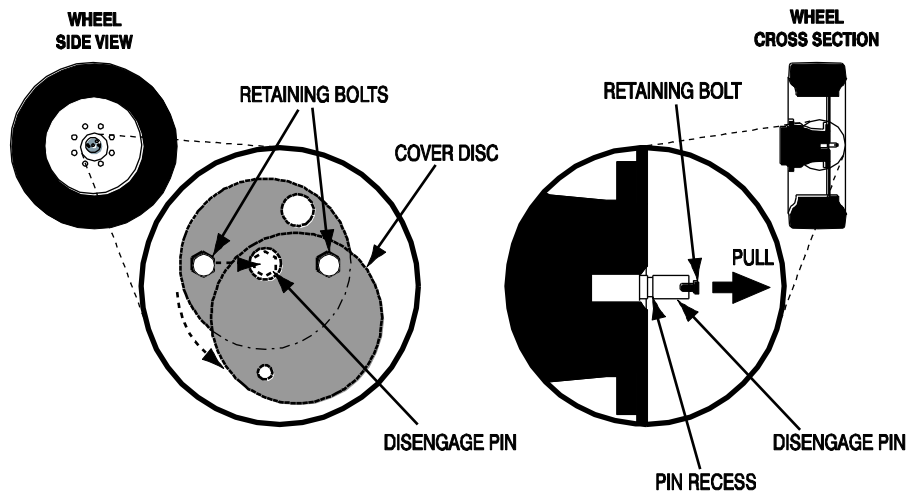

5.6 INCIDENT NOTIFICATION

It is a mandatory requirement that any accident or incident involving a Niftylift, regardless of whether any party received injury or property was damaged is reported by telephone directly to Niftylift. Failure to do so may render any warranty on the Niftylift void.

6 Responsibilities

6.1 CHANGES IN OWNERSHIP

When a change of ownership of a Niftylift occurs, it shall be the responsibility of the seller to notify Niftylift direct of the unit, model and serial number and the name and address of the new owner within 60 days. This important step is required so that all future Technical Bulletins are able to reach the registered owner of each Niftylift without delay. Please note warranties are not transferable.

6.2 MANUAL OF RESPONSIBILITIES

You are required by ANSI/SIA 92.5 2006, to read and understand your responsibilities before you use or operate this aerial platform. Please read the enclosed document, as failure to do so could result in death or serious injury. Wherever any contradiction may appear, the Manual of Responsibilities shall take precedence over all other documents.

6.3 Inspection/Service/Pre-Hire Check list

NIFTYLIFT SERIAL NO _____

TOWING	PASS	FAIL	N/A
Niftylift secured on trailer			
Straps correctly positioned and tightened			
Wheels chocked if necessary			
AXLES, WHEELS AND BRAKES			
Wheels are secure, tire condition acceptable			
Wheel bearings O.K.			
Brake linkages and cables secure			
Brake shoe wear not excessive			
Niftylift climbs slope			
Brakes hold Niftylift on slope			
Rear hub nut secure			
Track rod secure, not fouling axle plate			
BASE			
Operation of ground control valve and buttons			
Operation of all booms over full range			
Wheel bearings OK			
Cylinders are silent			
Basket is level over full range			
Booms, levelling rods not damaged or distorted			
Booms levelling rods, cylinders not fouling			
Hoses not tight, kinked or fouled			
Operation of manual hand pump			
BOOM ROTATION			
Boom rotation gear assembly and motor are secure			
Worm/wheel mesh correct, no excessive wear			
No end float of worm in housing			
Boom rotation gear wheel bolts secure			
Boom rotation gear guards secure			
PLATFORM			
Operation of control valve and buttons			
Operation of SiOPS			
Levelling lock valve holds in both directions, lines vented			
Operation of all booms over full range			
Cylinders are silent			
Basket levelling over full range			
Boom rotation smooth over full range			
Operation of boom 4 over full range (if fitted)			
No excessive movement of boom 4 and boom 3			

Operating & Safety Instructions

TILT ALARM	PASS	FAIL	N/A
Booms raised on slope - drive disabled, siren tone constant			
Boom operation unaffected			
Booms lowered - drive restored			
INTERNAL (POWER PACK)			
Power pack and all components secure			
All cables and terminals secure			
All hose connections secure			
Hoses not kinked or fouled			
Charger/control box secure			
Batteries secure			
Electrolyte level and specific gravity			
Charger operation			
Hydraulic oil level			
Engine/Gear box oil			
FINISH			
Pivot pin tag bolts			
Correct decals, all visible			
Canopy/bonnets			
Grease nipples (Feet, Knuckle, Centre Post)			
LEAK CHECK			
Cylinders (Lift, Jacks, Telescope, Levelling)			
Control valves			
Check valves			
Power pack/pump			
Boom rotation motor			
Hose connections			
Filter			
Wheel motors			

Comments, remedial work required etc;

INSPECTED BY: _____

DATE: / /