

OPERATION

| | | | |
|--|-----------|---|------------|
| 1. Identification of Important Parts | 55 | Fuse | 104 |
| Overview of the machine | 55 | Handling of Perimeter Monitoring Device (Camera Function) | 107 |
| Controls and switches | 56 | 3. Operating Instructions | 111 |
| 2. Description of Control Devices | 57 | Checking before starting the engine ... | 111 |
| LCD Monitor | 57 | Starting up the engine | 120 |
| Location and Function of | | Operating and checking instructions after starting the engine | 122 |
| Electrical Parts | 78 | Starting and stopping the machine | 124 |
| Control levers and pedals | 87 | Steering | 125 |
| Rear hood | 91 | Swinging the upperstructure | 126 |
| Front cover (right) | 91 | Operating the implement | 126 |
| Right hood | 92 | Precautions for operating the implement | 128 |
| Storage compartment for the operation & maintenance manual | 92 | Precautions for working | 130 |
| Storage space for tools and grease gun | 93 | Precautions for going up and down a slope | 131 |
| Windshield | 94 | Escaping from the mud | 132 |
| Hammer for emergency escape from operator's cab | 96 | Operations using the bucket | 133 |
| Operator's seat | 97 | Parking the machine | 135 |
| Headlight | 98 | Inspection requirements after completing operation | 136 |
| Left window glass | 98 | Stopping the engine | 136 |
| Cabin side door | 98 | Inspection requirements after stopping the engine | 136 |
| Replenishment of windshield washer fluid | 99 | Locking | 136 |
| Handling jog dial | 99 | Handling the rubber crawlers | 137 |
| Handling Air Conditioner | 101 | | |

Replacing the bucket without the quick coupler 141

Reversing the bucket without the quick coupler 142

Handling quick coupler 144

How to handle AUX2 (P.T.O.2) 152

Handling the thumb bracket 158

Handling accumulator 159

Handling diesel particulate filter (DPF)... 161

Handling SMARTASSIST-Remote (option) 167

4. Transportation 169

 Loading and unloading the machine..... 169

 Precautions for loading the machine ... 171

 Precautions for transporting the machine 172

 Suspending the machine 172

5. Care and Service in Cold Weather 174

 Preparing for cold weather 174

 Precautions after a day's work 175

 After cold weather ends 175

6. Long-term Storage 176

 Before storing 176

 Storing 177

 Using the machine again 177

7. Troubleshooting 178

 Packing the machine 178

 Inspection requirements after completing operation 178

 Stopping the engine 178

 Inspection requirements after stopping the engine 178

 Locking 178

 Handling the rubber crawlers 178

Phenomena that do not constitute faults 178

Towing 179

If the battery is overdischarged 179

Troubleshooting 183

Identification of the location of important parts 85

Review of the machine controls and switches 86

Description of the Control Devices 87

Control Devices 87

Location and function of the Control Devices 88

Control levers and pedals 89

Control levers and pedals 90

Control levers and pedals 91

Control levers and pedals 92

Control levers and pedals 93

Control levers and pedals 94

Control levers and pedals 95

Control levers and pedals 96

Control levers and pedals 97

Control levers and pedals 98

Control levers and pedals 99

Control levers and pedals 100

Control levers and pedals 101

1. Identification of Important Parts

Overview of the machine

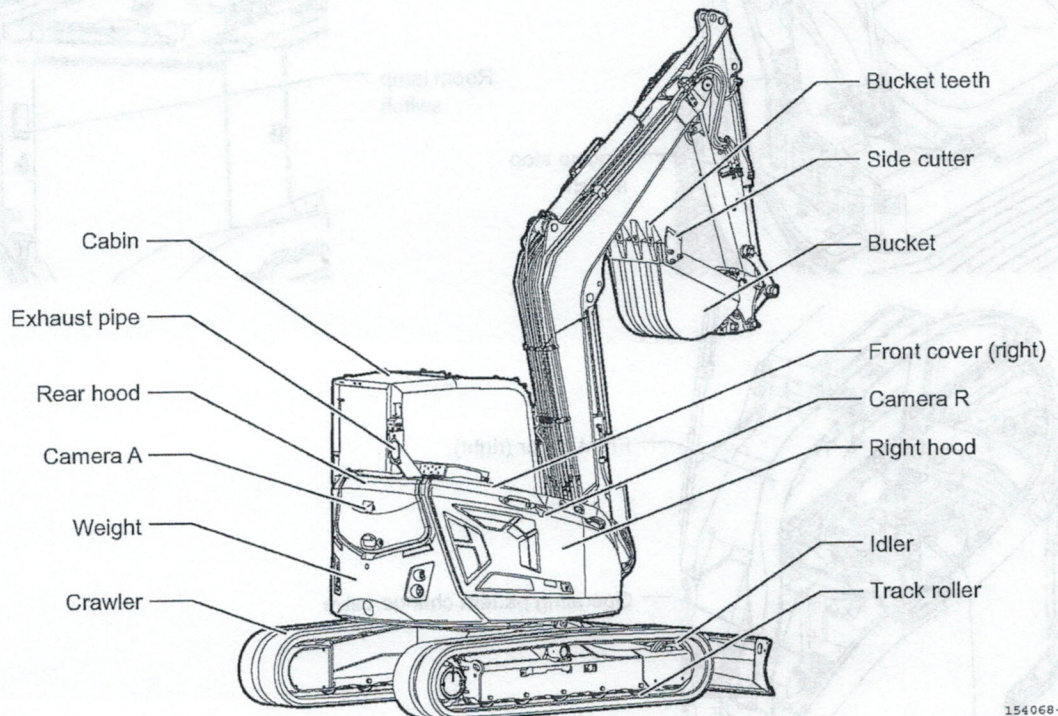
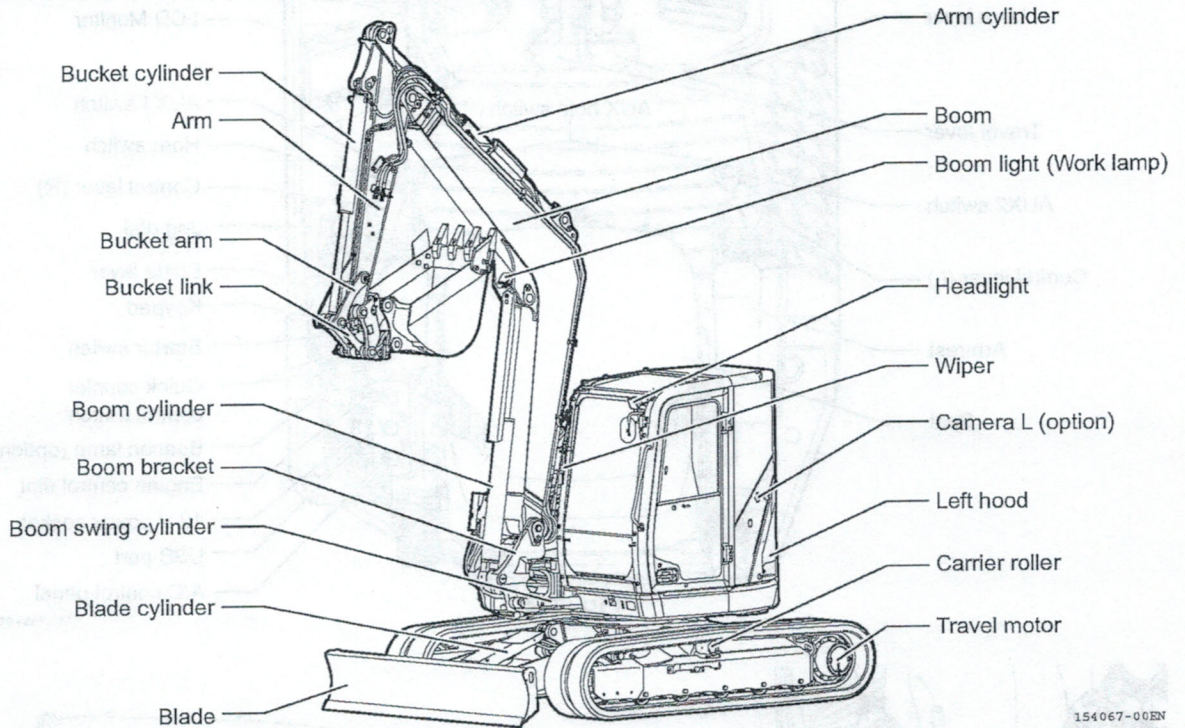

Fig. 1-1

Controls and switches

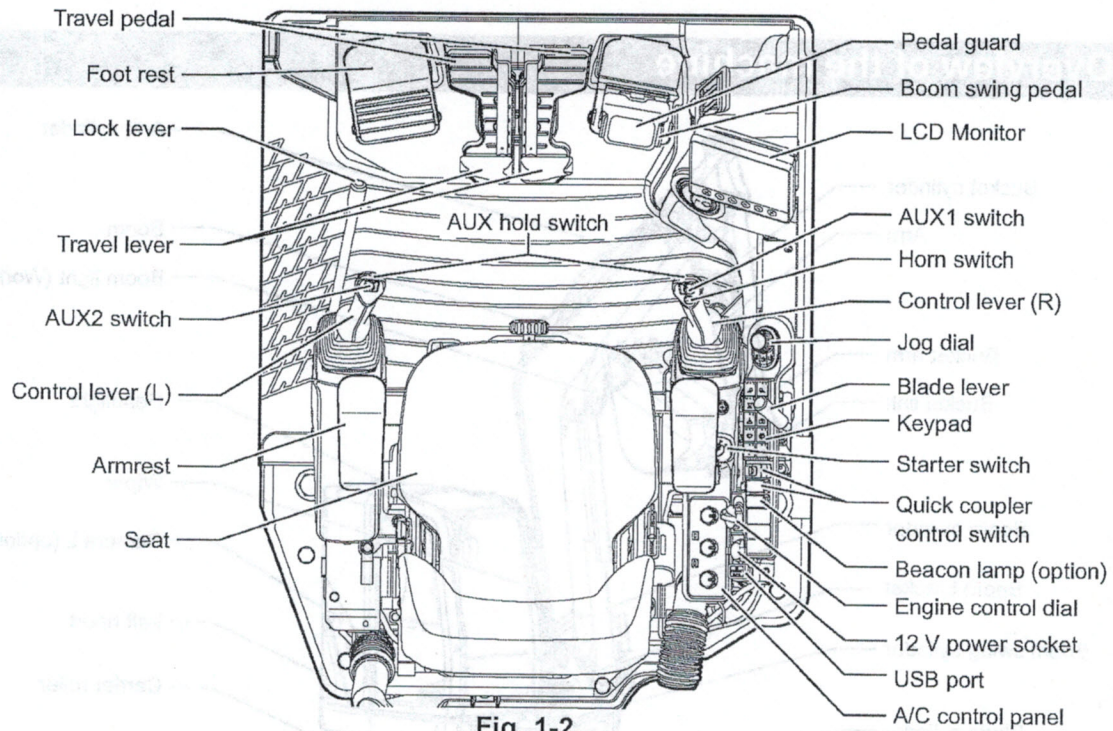

Fig. 1-2

153785-00EN

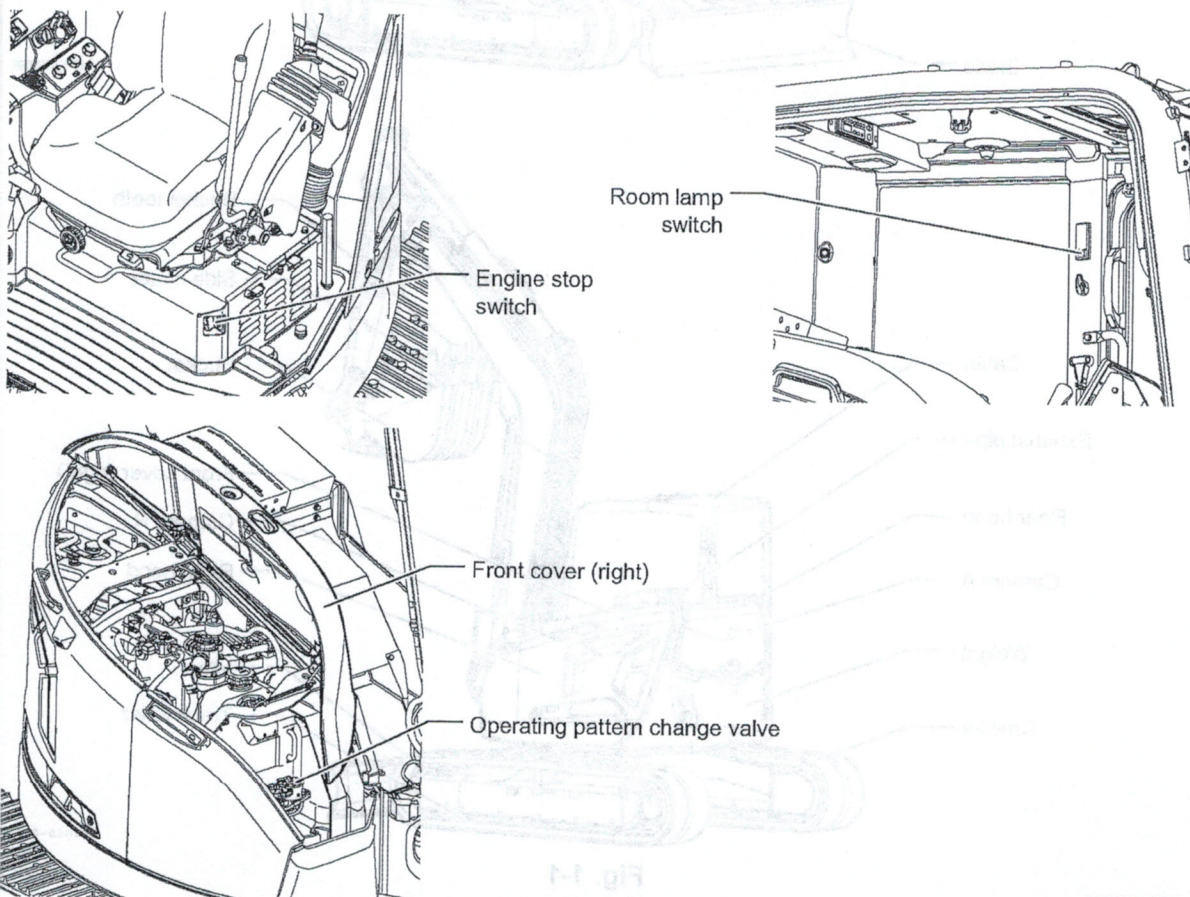

Fig. 1-3

155857-00EN

2. Description of Control Devices

This section describes several of the control devices necessary to operate the machine. In order to ensure safety and comfort in working with the machine, it is imperative for you to fully understand how to operate and interact with these devices.

LCD Monitor

Identification of Important Parts and Function

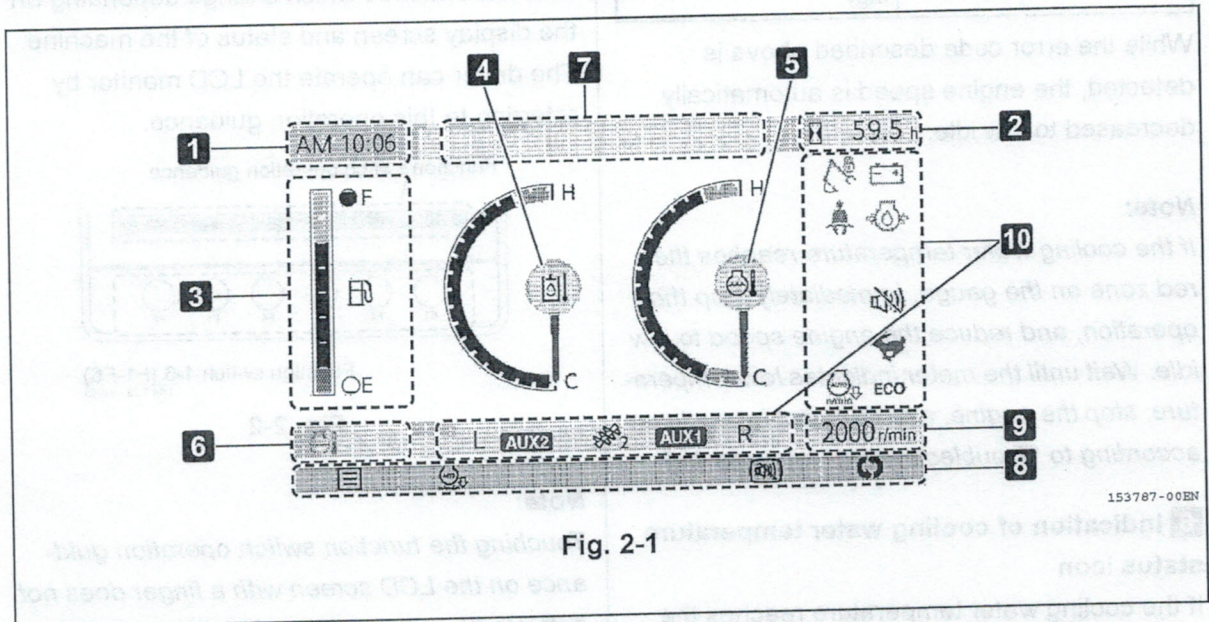

Fig. 2-1

1 Clock

The clock displays the current time. For the time setting method, refer to "Setting the Date and Time" on page 67.

Note:

Current time setting is retained for approximately 2 hours after the battery is removed.

2 Hour meter

The hour meter indicates the total accumulated hours of the machine operation. It accumulates the service hours of the engine, and the hour meter reading increases by "1" per hour. The digit at the far right registers "1" per 0.1 hours (6 minutes).

3 Fuel meter

The fuel meter indicates the amount of fuel remaining in the fuel tank.

If the fuel level is low, a message to refill the fuel tank is displayed in the warning indication area, and the notification buzzer sounds.

4 Hydraulic oil temperature gauge

This gauge indicates the hydraulic oil temperature.

5 Cooling water temperature gauge

This gauge indicates the temperature of the engine cooling water.

If the cooling water temperature reaches the red zone on the gauge, the "Error occurring" message is displayed in the warning display area, and the warning buzzer sounds.

| Error code | Category | Contents |
|--------------|----------|--|
| 28.000110.00 | Warning | Abnormal cooling water temperature (overheating) |

While the error code described above is detected, the engine speed is automatically decreased to low idle.

Note:

If the cooling water temperature reaches the red zone on the gauge, immediately stop the operation, and reduce the engine speed to low idle. Wait until the meter indicates low temperature, stop the engine, and carry out inspections according to "Troubleshooting" on page 183.

6 Indication of cooling water temperature status icon

If the cooling water temperature reaches the red or blue zone on the gauge, the icon indicating cooling water temperature status is displayed.

| Icon | Icon color | Contents |
|------|------------|---|
| | Red | If the cooling water temperature exceeds 230 °F (110 °C), the red icon is displayed. |
| | Blue | If the cooling water temperature falls below 86 °F (30 °C), the blue icon is displayed. |

7 Warning display area

When an error occurs to the machine or maintenance notice is issued, contents of those are displayed.

For the display when an error occurs to the machine, refer to "Warning and Display when Error Occurs" on page 63.

8 Function switch operation guidance

The guidance displays the functions of the function switches which change depending on the display screen and status of the machine. The driver can operate the LCD monitor by referring to this operation guidance.

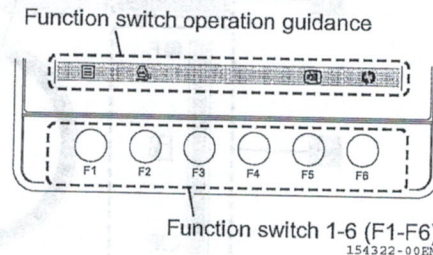

Fig. 2-2

Note:

Touching the function switch operation guidance on the LCD screen with a finger does not activate its corresponding function.

9 Switching display area

Each time F6 is pushed, the display switches among the engine speed, instantaneous fuel consumption, and cooling water temperature in this order.

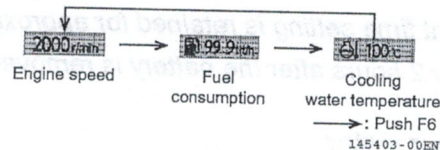

Fig. 2-3

Note:

When the function of the F6 button is changed, such as when an error occurs or a message is issued to notify that the maintenance time has passed, the display in the switching display area cannot be switched.

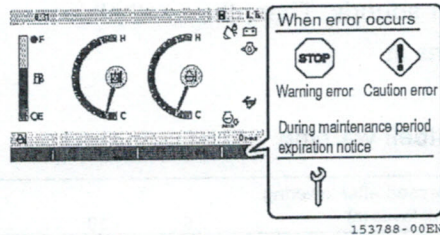

Fig. 2-4

10 Icon display area

When the display condition of each icon is satisfied, each icon lights up or flashes. For the explanations of each icon, refer to "Icon Display" in the following section.

Icon Display

Fig. 2-5

1 Battery charge icon

This icon lights up and the warning message is displayed in the warning display area if the battery is not charged properly while the engine is running, and the caution buzzer sounds at the same time.

When this icon lights up and the buzzer sounds, inspect the battery charge circuit, and if any problems are found, take the necessary corrective measures according to "Troubleshooting" on page 183.

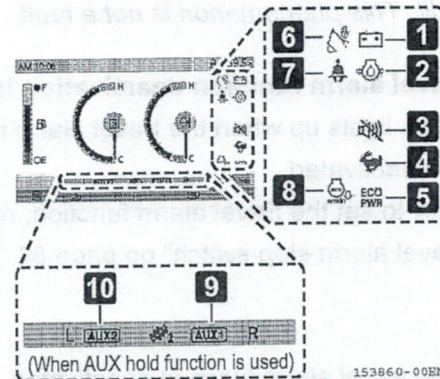
Note:

While the key is in the "ON" position, the icon stays lit. This phenomenon is not a fault.

2 Engine oil pressure icon

This icon lights up and the warning message is displayed in the warning display area if the engine oil pressure falls below the normal range, and the warning buzzer sounds at the same time.

If this icon lights up and the buzzer sounds, immediately stop the engine and carry out inspections according to "Troubleshooting" on page 183.

Note:

While the key is in the "ON" position, the icon stays lit. This phenomenon is not a fault.

3 Travel alarm function deactivation icon

This icon lights up when the travel alarm function is deactivated.

For how to set the travel alarm function, refer to "Travel alarm stop switch" on page 84.

Note:

With the travel alarm function deactivated, stop the engine and turn the key to the "ON" position again to automatically activate the travel alarm function.

4 High speed travel icon

This icon lights up while the traveling speed is set to the 2nd speed.

For how to set the traveling speed, refer to "Location and Function of Electrical Parts" on page 78.

5 ECO/POWER mode icon

This icon is displayed while the ECO/POWER mode is set.

| Icon | Operation mode |
|------|----------------|
| — | NORMAL |
| ECO | ECO mode |
| PWR | Power mode |

For how to set the operation mode, refer to "Home Screen Operation" on page 65 or "Machine Settings" on page 70.

6 Lock lever icon

This icon is displayed while the lock lever is raised.

7 Seatbelt warning icon

This icon is displayed when the seatbelt is not fastened with the lock lever lowered. After the lock lever is lowered and the period without fastening the seatbelt continues for 5 seconds, this icon flashes for 5 seconds and the caution buzzer sounds. Then, the seatbelt icon remains lit.

- Seatbelt warning

| Seatbelt fastening status | Time elapsed after lowering the cutoff lever (s) | | | |
|---------------------------|--|----------------|----|-----|
| | 5 | | 10 | |
| Seatbelt warning icon | ON | Flashing | ON | OFF |
| Warning buzzer | - | Caution buzzer | - | - |

152880-00EN

8 Auto deceleration function working icon

This icon lights up when the auto deceleration function is turned ON and goes off when turned OFF.

For how to set the auto deceleration function, refer to "Home Screen Operation" on page 65 or "Machine Settings" on page 70.

9 Right control lever AUX allocation icon

10 Left control lever AUX allocation icon

This icon displays AUX allocated to the AUX switch of the control lever. When the hold function of the AUX flow rate is used, the applicable icon is highlighted.

For how to allocate AUX, refer to "Setting the AUX Operation Allocation" on page 71.

Operation at Start-up

1. When the starter switch is turned to the "ON" position, the start screen is displayed for 2 seconds and the buzzer sounds. Then, the passcode entry screen appears when the passcode set function is ON. The home screen appears when the passcode set function is OFF.

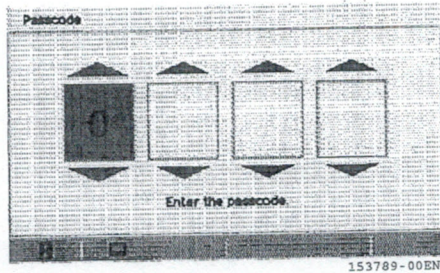

Passcode entry screen

Fig. 2-6

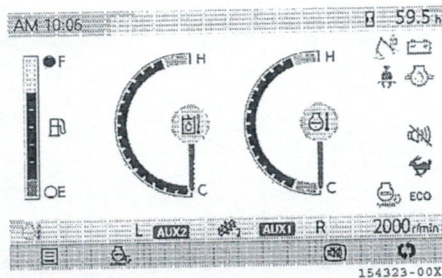

Home screen

Fig. 2-7

- How to enter passcode (when the passcode set function is ON)
Passcode can be entered into the LCD monitor by operating the function switch (jog dial) on the LCD monitor or the key-pad.

On the passcode entry screen, the numerical values on the keypad light up, and each numerical value on the top right of each switch is entered into the LCD monitor.

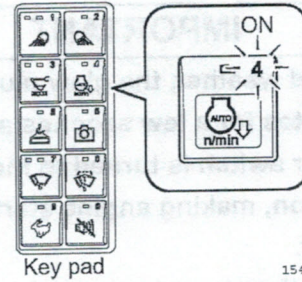

Fig. 2-8

The entered passcode is verified with the passcode stored in the machine, and if the verification is successful, the screen is switched to the home screen.

IMPORTANT

If the passcode verification fails five times consecutively, the horn keeps sounding for 1 minute. After the horn stops sounding, turn the key to the "OFF" position. If the key is turned to the "OFF" position before the horn stops sounding, turning the key back to the "ON" position activates the horn for 1 minute.

2. After confirming that the home screen is displayed, turn the key to the "START" position to start the engine.

IMPORTANT

In cold weather, the glow plug operates for a few seconds after the starter switch is turned to the "ON" position, making engine starting easier.

While the glow plug operates, the LCD monitor shows the screen indicating that the glow plug is operating.

When the engine has been warmed up, the screen changes to the home screen. After confirming that the home screen is displayed, start the engine.



Glow plugs activated. Please wait.

145407-00EN

Note:

- When the key is set to the "START" position with the cut-off lever lowered, a notice to raise the lock lever is issued to the driver. The engine cannot be started while the lock lever is lowered. Raise the lock lever before starting the engine.



Lift the lock lever.

Fig. 2-9

145408-00EN

- If there is an item whose maintenance time has passed, the home screen is displayed, then a notification buzzer sounds only once, and the home screen shows that there is an item whose maintenance time has passed for 30 seconds.



Warning and Display when Error Occurs

■ Operation when error occurs

If an error occurs to the machine, the "Error occurring" message is displayed in the warning display area on the LCD screen, and a buzzer sounds according to the error level.



145410-00EN

When warning error occurs
(Background color: Red,
Character color: White)



145411-00EN

When caution error occurs
(Background color: Yellow,
Character color: Black)

Error display icon

| Icon | Display condition |
|------|--|
| | Displayed if a warning-level error occurs |
| | Displayed if a caution-level error occurs |
| | Displayed if an error related to nitrogen oxides (NOx) in exhaust gas occurs |
| | Displayed if an error related to particulate matter (PM) in exhaust gas occurs |
| | Displayed if a Diesel Particulate Filter (DPF) regeneration request occurs |

■ Warning display

IMPORTANT

If a warning-level error occurs, immediately stop the operation and take the necessary corrective measures.

If a warning-level error occurs, the notice of error occurrence is displayed in the warning display area, and the F6 function operation guidance (switching display area) icon is switched to the warning icon. Pushing F6 switches the screen to the error information screen.

■ Caution display

⚠ CAUTION

If a caution-level error occurs, take the necessary corrective action as soon as possible.

If a caution-level error occurs, the notice of error occurrence is displayed in the warning display area, and the F6 function operation guidance (switching display area) icon is switched to the caution icon. Pushing F6 switches the screen to the error information screen.

Alarm patterns of buzzer

Five alarm patterns are available for the buzzer depending on each operation and error content. When multiple alarm conditions are met at the same time, the alarm in the category with a higher priority is issued.

| Priority | Category | Pattern |
|----------|---------------------|-------------------|
| 1 | Warning buzzer | Continuous beep |
| 2 | Caution buzzer | Repeated beeps |
| 3 | Notification buzzer | Three short beeps |
| 4 | Stop buzzer | One long beep |
| 5 | Confirmation buzzer | One short beep |

Warning and caution buzzers can be temporarily stopped by pushing F3 while the error information screen or error information detail screen is displayed.

Note:

While the warning buzzer is sounding, even when the buzzer is temporarily stopped, it sounds again when the screen returns to the home screen.

■ Operation when the starter switch is "OFF"

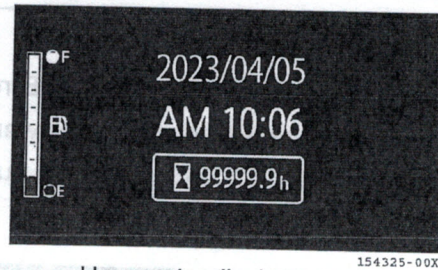

Hour meter display screen (with the key "OFF")

Fig. 2-10

1. Even when the starter switch is "OFF", pushing and holding the F1 button displays the opening screen for two seconds and then brings up the hour meter display screen. The hour meter display screen shows the date and time, hour meter, and residual quantity of fuel.
2. Pushing the F2 button on this screen brings up the "Check and reset the time" screen, and pushing the F3 button brings up the "Operation management" screen.

Note:

"Check and reset the time" screen and "Operation management" screen cannot be reset.

3. The display on the LCD monitor screen will disappear when 10 seconds or more have elapsed after the last button operation.

Home Screen Operation

Operate the function switches on the home screen to use the functions allocated to the function switches.

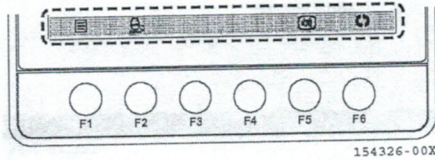

Fig. 2-11

| | |
|----|---|
| F1 | Returns to the menu screen. |
| F2 | Turns ON/OFF the auto deceleration function. For the explanations of the auto deceleration function, refer to "Auto deceleration switch" on page 82. |
| F3 | Selects the engine output mode. For the explanations of the engine output mode, refer to "Output mode selector switch" on page 82. |
| F4 | Each time the switch is pushed, the five attachment flow rates set in the AUX flow rate setting are switched. For the explanations of the AUX flow rate setting, refer to "Changing the AUX Maximum Flow Rate and Switching the Attachments" on page 71. |
| F5 | Turns ON/OFF the travel alarm stop function. For the explanations of the travel alarm stop function, refer to "Travel alarm stop switch" on page 84. |
| F6 | The functions that can be used differ depending on the machine status. <ul style="list-style-type: none"> • Normal: Changes the display of the switching display area. • When an error code is issued: Moves to the error information screen. • During maintenance notice: Moves to the maintenance part elapsed time list screen. |

Automatic change of display screen

When the LCD monitor shows other than the home screen, satisfying any of the following conditions will automatically brings up the home screen.

- No LCD monitor operation for 60 seconds or more
- Traveling operation

| Function | Explanation of display item |
|------------|--|
| Menu | Used to set the language, data and time, display data, monitor operation, sound and screen brightness. |
| Home | Used to turn ON/OFF various functions or select the home screen. |
| Engine | Used to control the maximum flow rate for AUX operation. |
| AUX | Five settings can be stored at the maximum. |
| Travel | Used to display the operating status of the machine, such as battery voltage and engine speed. |
| Operation | Used to check and measure the set value. |
| Warning | Used to check the maintenance time interval and the accumulated hours since the last maintenance, and read the accumulated hours after the timing maintenance. |
| Error | Used to check the error code in the detected error. |
| Error list | The history of up to 10 error codes, including past error codes can be checked. |
| Filter | Used to perform the manual Diesel particulate Filter (DPF) regeneration. |

Menu Screen

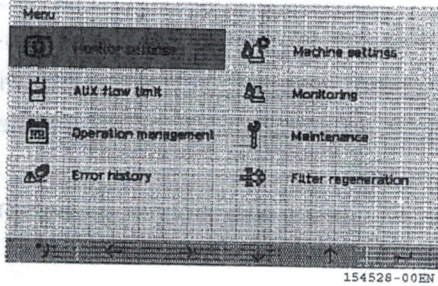

Menu screen

Fig. 2-12

Pushing F1 (menu) on the home screen brings up the menu screen.

On the menu screen, the following items can be displayed, set, and operated.

| Display item | Explanation of display item |
|----------------------|---|
| Monitor settings | Used to set the language, date and time, display units, monitor operation sound, and screen brightness. |
| Machine settings | Used to turn ON/OFF various functions or select the control mode. |
| AUX flow limit | Used to control the maximum flow rate for AUX operation. Five settings can be stored at the maximum. |
| Monitoring | Used to display the operating status of the machine, such as battery voltage and engine speed. |
| Operation management | Used to check and measure the service hours. |
| Maintenance | Used to check the maintenance time interval and the accumulated hours since the last maintenance, and reset the accumulated hours after performing maintenance. |
| Error history | Used to check the error code of the detected error. The history of up to 10 error codes including past error codes can be checked. |
| Filter regeneration | Used to perform the manual Diesel Particulate Filter (DPF) regeneration. |

Monitor Settings

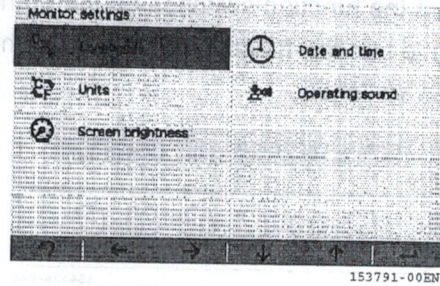

Monitor settings screen

Fig. 2-13

Selecting the "Monitor settings" on the menu screen and pushing F6 (Set) brings up the monitor settings screen. On the monitor settings screen, the following items can be set.

Monitor settings item

| Setting item | Setting contents |
|-------------------|--|
| Languages | Used to change the language to be displayed on the monitor. |
| Date and time | Used to set the display method of the date and time. |
| Units | Used to set each unit of volume, temperature, length, and pressure. |
| Operating sound | Used to set whether to emit the confirmation buzzer when a function switch is pushed. |
| Screen brightness | Used to set the brightness level of the monitor screen. Settings can be made for when the work light is on and when it is off. |

Setting the Language

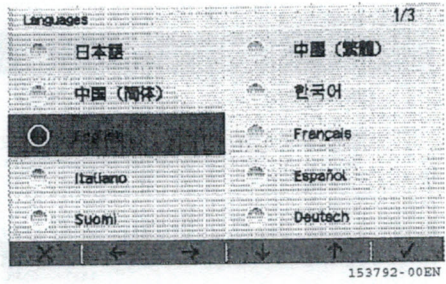

Language setting screen

Fig. 2-14

Selecting the language setting from the monitor settings and pushing F6 (Set) brings up the language setting screen. The available languages are as follows.

Japanese, Chinese (Traditional), Chinese (Simplified), Korean, English, French, French (Canadian), Italian, Spanish, Spanish (Mexico), Finnish, German, Portuguese, Portuguese (Brazil), Russian, Swedish, Dutch, Polish, Danish, Czech, Thai, Indonesian, Vietnamese, Malaysian, Turkish, Symbol

Note:

If the desired language is not available, select the "Symbol".

Setting the Date and Time

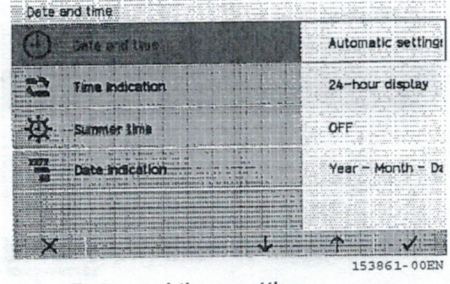

Date and time setting screen

Fig. 2-15

Selecting the "Date and time" from the monitor settings and pushing F6 (Set) brings up the date setting screen. Selecting the "Date and time" from the Date and time setting screen and pushing F6 (Set) brings up the automatic setting/manual setting selection screen.

- Automatic setting method

Date and time can be automatically set by obtaining the date and time information from SA-R (SMARTASSIST-Remote). Selecting the "Automatic setting" and pushing F6 (Set) brings up the time zone selection screen. Select the time zone of the area where this machine is used and push F6 (Set).

- Manual settings

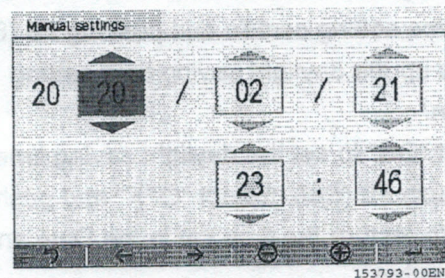

Manual settings screen

Fig. 2-16

Selecting the "Manual settings" and pushing F6 (Set) brings up the manual date setting screen. Push the function switch to select the section to be changed, set the desired time, and push F6 (Set).

Changing the 12/24 Hours Display

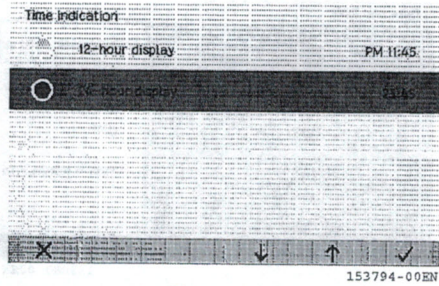

Time indication setting screen

Fig. 2-17

Selecting the "Time indication" from the Date and time setting screen and pushing F6 (Set) brings up the time display setting screen. Select the desired display and push F6 (Set).

Setting Daylight Saving Time

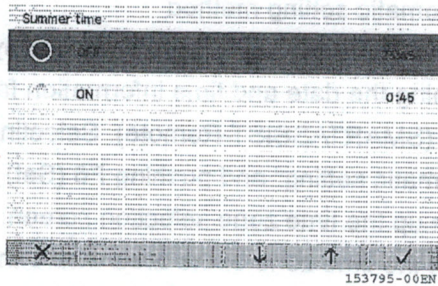

Daylight saving time setting screen

Fig. 2-18

Selecting the "Summer time" from the Date and time setting screen and pushing F6 (Set) brings up the daylight saving time setting screen. Select "ON" to set the daylight saving time, and push F6 (Set). Select "OFF" and push F6 (Set) to restore the time set in the Date and time setting.

Note:

When the daylight saving time is set, the time is displayed one hour earlier.

Setting the Date Display

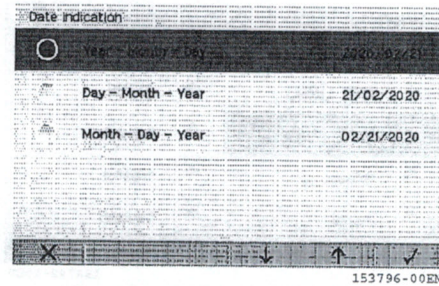

Date indication setting screen

Fig. 2-19

Selecting the "Date indication" from the Date and time setting screen and pushing F6 (Set) brings up the date display setting screen. Select the desired order and push F6 (Set).

| Item | Explanation | Display example |
|----------------|--|-----------------|
| Year-Month-Day | Displays in order of year, month, and day. | 2023/12/23 |
| Day-Month-Year | Displays in order of day, month, and year. | 23/12/2023 |
| Month-Day-Year | Displays in order of month, day, and year. | 12/23/2023 |

Setting the Display Units

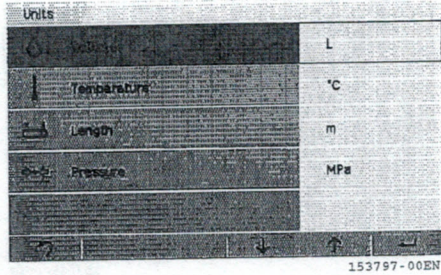

Unit setting screen

Fig. 2-20

Selecting the "Units" from the monitor settings and pushing F6 (Set) brings up the unit setting screen. Selecting the desired item and pushing F6 (Set) brings up the screen to change the display unit. Select the desired display unit and push F6 (Set) to change the display unit. The available units are as follows.

| Item | Display unit |
|-------------|---------------------------|
| Volume | - L - gal (US) - gal (UK) |
| Temperature | - °C - °F |
| Length | - m - ft |
| Pressure | - MPa - bar - PSI |

Setting the Monitor Operating Sound

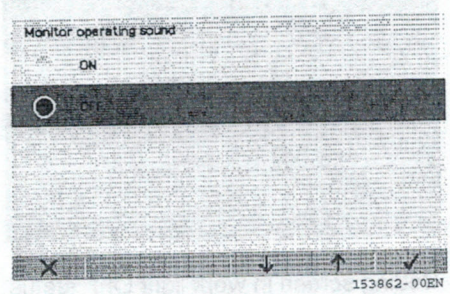

Setting screen of monitor operating sound

Fig. 2-21

Selecting the "Monitor operating sound" from the monitor settings and pushing F6 (Set) brings up the setting screen of monitor operating sound. Select "ON" to set the monitor operating sound, and push F6 (Set). Selecting "OFF" and pushing F6 (Set) stops the operation sound when a function switch is operated.

Setting the Screen Brightness

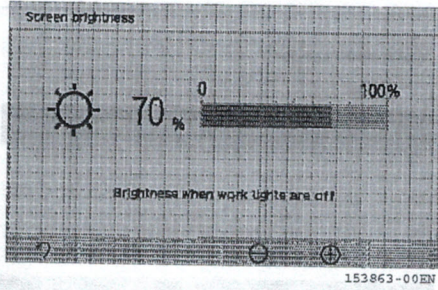

Setting screen in work light OFF status

Fig. 2-22

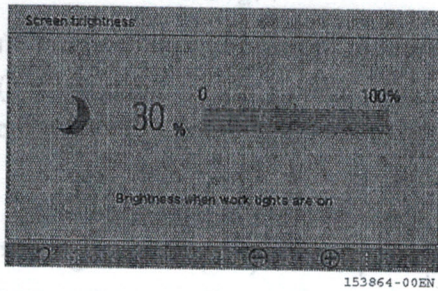

Setting screen in work light ON status

Fig. 2-23

Selecting the "Screen brightness" from the monitor settings and pushing F6 (Set) brings up the screen brightness setting screen. Operate F4 or F5 to change the brightness to the desired level.

Note:

When the work light is turned on and off, the screen changes between the screen brightness setting screen in work light ON status and that in work light OFF status.

Machine Settings

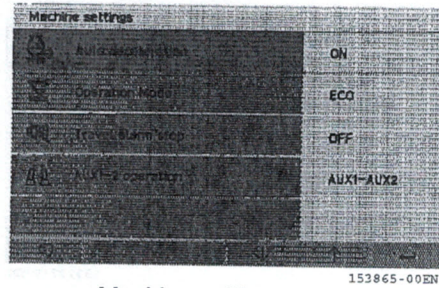

Machine settings screen

Fig. 2-24

Selecting the "Machine settings" on the menu screen and pushing F6 (Set) brings up the machine settings screen. On the machine settings screen, the current setting contents can be checked and various functions can be set. The current setting contents are displayed on the right side of each setting item.

Setting item

| Setting item | Setting contents |
|-----------------------------|--|
| Auto deceleration | Selecting the auto deceleration and pushing F6 (Set) turns ON/OFF the auto deceleration function. |
| Operation Mode | Selecting the operation mode and pushing F6 (Set) changes the output mode between ECO and NORMAL. |
| Travel alarm stop | Selecting the travel alarm stop and pushing F6 (Set) turns ON/OFF the travel alarm stop function. Note: Turning the key to the "OFF" position returns the alarm stop function setting to "OFF". To turn the alarm stop function to "ON", set it each time. |
| AUX1-2 operation allocation | Selecting the AUX1-2 operation allocation and pushing F6 (Set) brings up the AUX1-2 operation allocation setting screen, where you can change the allocation of the AUX control lever. |

Setting the AUX Operation Allocation

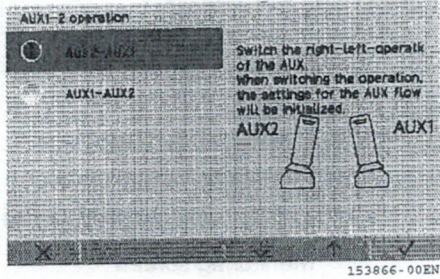

AUX1-2 operation screen
(When AUX2-AUX1 is selected)

Fig. 2-25

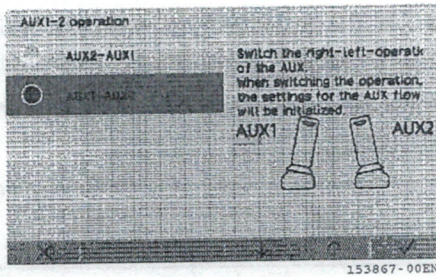

AUX1-2 operation screen
(When AUX1-AUX2 is selected)

Fig. 2-26

Selecting the "AUX1-2 operation" from the machine settings and pushing F6 (Set) brings up the screen for setting the allocation of the control lever operating the AUX.

| Item | Control lever (L) | Control lever (R) |
|-------------|--------------------|--------------------|
| AUX2 - AUX1 | Operates the AUX2. | Operates the AUX1. |
| AUX1 - AUX2 | Operates the AUX1. | Operates the AUX2. |

Changing the AUX Maximum Flow Rate and Switching the Attachments

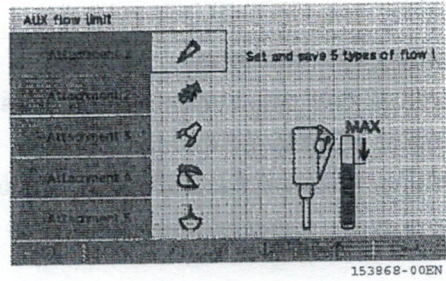

AUX flow limit screen

Fig. 2-27

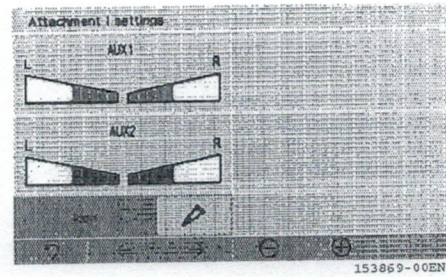

AUX maximum flow limit setting screen

Fig. 2-28

Selecting the "AUX flow limit" on the menu screen and pushing F6 (Set) brings up the AUX flow limit screen. On this screen, the maximum of 5 AUX flow rates can be set for the attachments and the set flow rate of the attachment can be changed.

[How to set AUX maximum flow rate]

1. On the AUX flow rate control screen, selecting the desired attachment and pushing F6 (Set) brings up the AUX maximum flow rate setting screen.
2. Push F2 or F3 to select the AUX port whose maximum flow rate is to be controlled, and push F4 or F5 to set the desired flow rate.
3. Selecting the icon and pushing F6 (Set) brings up the screen for changing the icon display. Select any icon and push F6 (Set).

Note:

The AUX ports to be displayed on the AUX maximum flow rate setting screen varies depending on the specifications.

[Switching attachments]

On the AUX flow rate control screen, selecting the desired attachment and pushing F1 (Return) controls the maximum flow rate to the set value of the selected attachment.

Monitoring

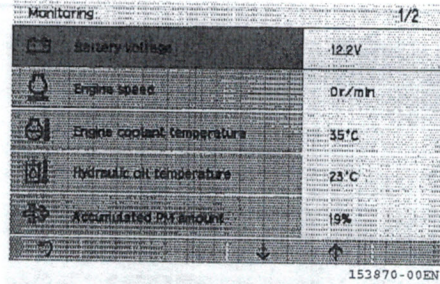

Monitoring screen

Fig. 2-29

Selecting the "Monitoring" on the menu screen and pushing F6 (Set) brings up the monitoring screen. On the monitoring screen, the voltage value, temperature, amount, etc. are displayed by reading them from the information of the sensors installed in this machine.

On the monitoring screen, the following items can be checked.

| Display item | |
|----------------------------|------------------------------|
| Battery voltage | Ash accumulation amount |
| Engine speed | Filter inlet temperature |
| Engine coolant temperature | Mid-filter temperature |
| Hydraulic oil temperature | Filter inlet pressure |
| Accumulated PM amount | Filter differential pressure |

Checking and Measuring the Operation Status of This Machine

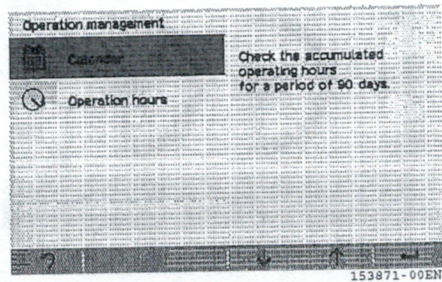

Operation management screen

Fig. 2-30

Selecting the "Operation management" on the menu screen and pushing F6 (Set) brings up the operation management screen. On the operation management screen, the service hours can be checked and measured.

• Checking the operation status

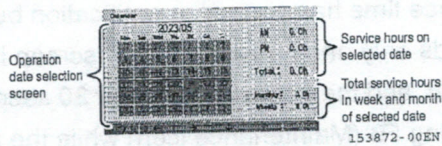

Calendar screen

Fig. 2-31

Select the "Calendar" on the operation control screen and push F6 (Set) to check the service hours of 90 days at maximum.

Select the desired date on the calendar on the left side of the screen to display the service hours for the selected date and the total service hours for the week and month of the selected date on the right side of the screen.

The number of dots under the date on the calendar gives an estimate of the total service hours for the day.

| No. of dots | Service hour |
|-------------|---------------------------------|
| 0 | Less than 0.5 h |
| 1 | 0.5 or more and less than 2.0 h |
| 2 | 2.0 or more and less than 4.0 h |
| 3 | 4.0 or more and less than 8.0 h |
| 4 | 8.0 h or more |

Note:

- Service hour is added every 0.1 hours (6 minutes).
- Pushing and holding F2/F3 (←/→) changes the date continuously at 5 days/s.
- Pushing and holding F4/F5 (↓/↑) changes the date continuously at 5 weeks/s.

• Measuring the Service Hours

Selecting the "Operation hours" on the operation management screen displays the date and time when the measurement is started and the service hours from the measurement start date and time.

Selecting the "Operation hours" and pushing F6 (Reset) and then F6 (Set) again indicates a time reset notice and resets the service hours. When the service hours are reset, the date and time when the service hours are reset are stored, and measurement is started again from the time of resetting.

Checking the Maintenance Part Elapsed Time

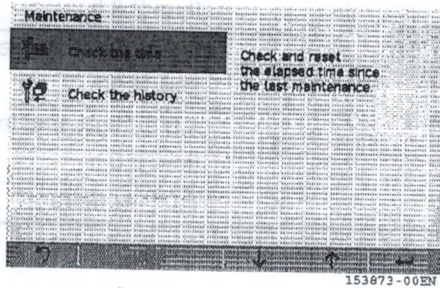

Maintenance screen

Fig. 2-32

Selecting the "Maintenance" on the menu screen and pushing F6 (Set) brings up the maintenance screen. On the maintenance screen, the elapsed time of maintenance parts can be checked, the elapsed time can be reset, and the replacement history of maintenance parts can be checked.

Maintenance parts for checking elapsed time

| | |
|---------------------------------------|-----------------------------|
| Hydraulic oil | Hydraulic oil return filter |
| Hydraulic oil line filter | Engine oil |
| Engine oil filter | Air cleaner element |
| Fuel filter element | Fuel pre-filter element |
| Lube oil for travel reduction gearbox | |

• Checking the elapsed time

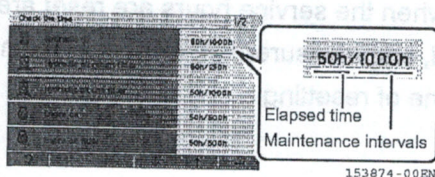
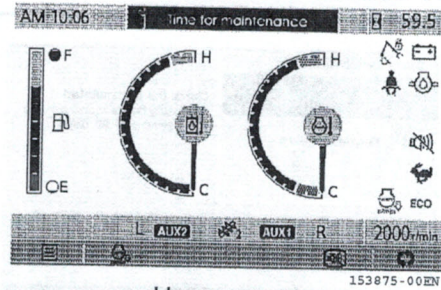

Fig. 2-33

Select the "Check the time" on the maintenance screen and push F6 (Set) to check the elapsed time and maintenance time intervals for each maintenance part.

• Display when the maintenance time has passed



Home screen

(when the maintenance time has passed)

Fig. 2-34

After the maintenance time has passed, a notification buzzer sounds only once and a notification message is displayed in the warning display area on the home screen for 30 seconds.

When the key is set to the "OFF" position and then to the "ON" position again after the maintenance time has passed, a notification buzzer sounds only once after the home screen is displayed, and the notice remains for 30 seconds. Pushing F6 (Maintenance icon) while the notification message is displayed brings up the maintenance screen.

Note:

If there is any part whose maintenance time has passed, the "Check the time" icon on the maintenance screen and icons for the parts whose maintenance time has passed on the Check the time screen are changed to yellow.

• **Resetting the elapsed time**

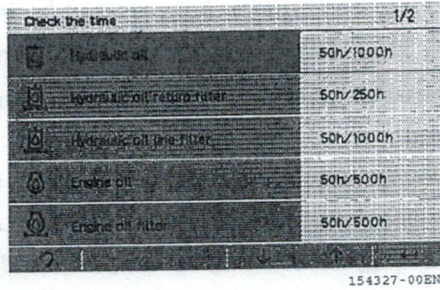

Check the time screen

Fig. 2-35

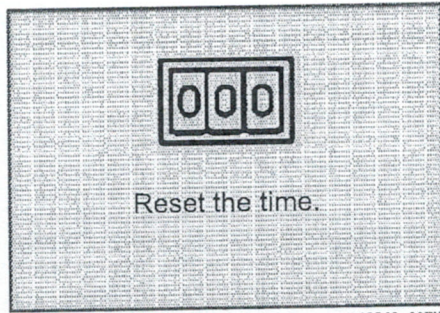

Elapsed time reset notice

Fig. 2-36

Selecting the replaced maintenance part and pushing F6 (Reset) displays the elapsed time reset notice. Pushing F6 (Set) with the elapsed time reset notice displayed resets the elapsed time.

IMPORTANT

After the maintenance parts are replaced, make sure to reset the elapsed time.
 If the elapsed time is not reset, the notification message will appear on the home screen each time the key is turned to the "ON" position after the maintenance time has passed.

• **Checking the replacement history of maintenance parts**

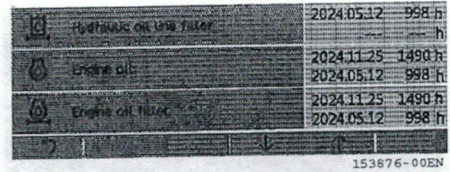
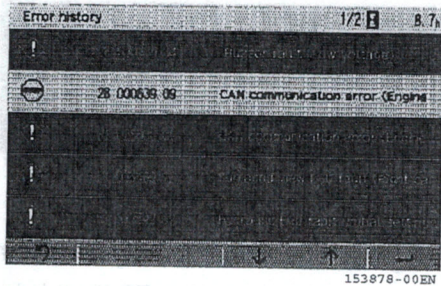

Fig. 2-37

Selecting the "Check the history" on the maintenance screen and pushing F6 (Set) brings up the maintenance history screen.

On the maintenance history screen, the date when the elapsed time of maintenance parts is reset and the hour meter at the time of reset are displayed for the past two times.

Checking the Error History



Error history screen

Fig. 2-38

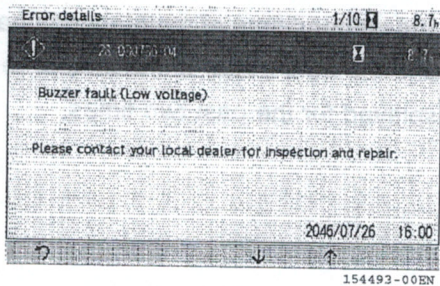

Error details screen

Fig. 2-39

Selecting the "Error history" on the menu screen and pushing F6 (Set) brings up the error history screen. The error history screen displays up to 10 error codes including past error codes.

The display color of the error code is changed according to the warning level of the error code, and the currently occurring error display icon is blinked for display.

| Warning level | Background color/ Character color |
|---------------|--------------------------------------|
| Warning | Red/White |
| Caution | Yellow/Black |

Selecting the desired error code on the error history screen and pushing F6 (Set) brings up the error information detail screen. The details of the error code and service hours at the error occurrence can be checked.

Note:

- Warning and caution buzzers can be temporarily stopped by pushing F3 on the error information screen or error information detail screen.
- While the warning buzzer is sounding, even when the buzzer is temporarily stopped, it sounds again when the screen returns to the home screen.

Regenerating Diesel Particulate Filter (DPF) Manually

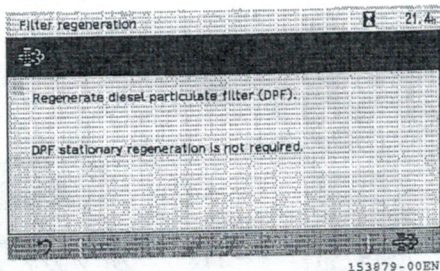

Filter regeneration screen
(Unable to regenerate DPF)

Fig. 2-40

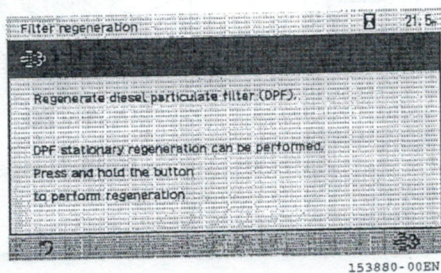

Filter regeneration screen
(Enable to regenerate DPF)

Fig. 2-41

⚠ WARNING

- During DPF regeneration, the temperature around the exhaust pipe and muffler and the exhaust gas temperature increase to high levels. Park the machine in a location where there are no persons or flammable objects to carry out the manual regeneration.
- Carry out DPF regeneration in a well-ventilated and spacious outdoor location. Because exhaust gas contains colorless and odorless harmful carbon monoxide, inhalation of exhaust gas may cause carbon monoxide poisoning and it is dangerous.

Selecting the "Filter regeneration" on the menu screen and pushing F6 (Set) brings up the filter regeneration screen.

To regenerate DPF, refer to "Handling diesel particulate filter (DPF)" on page 161. When the DPF regeneration is possible, push and hold F6 (Regenerate) to regenerate DPF.

To regenerate DPF manually, refer to "Handling diesel particulate filter (DPF)" on page 161.

Location and Function of Electrical Parts

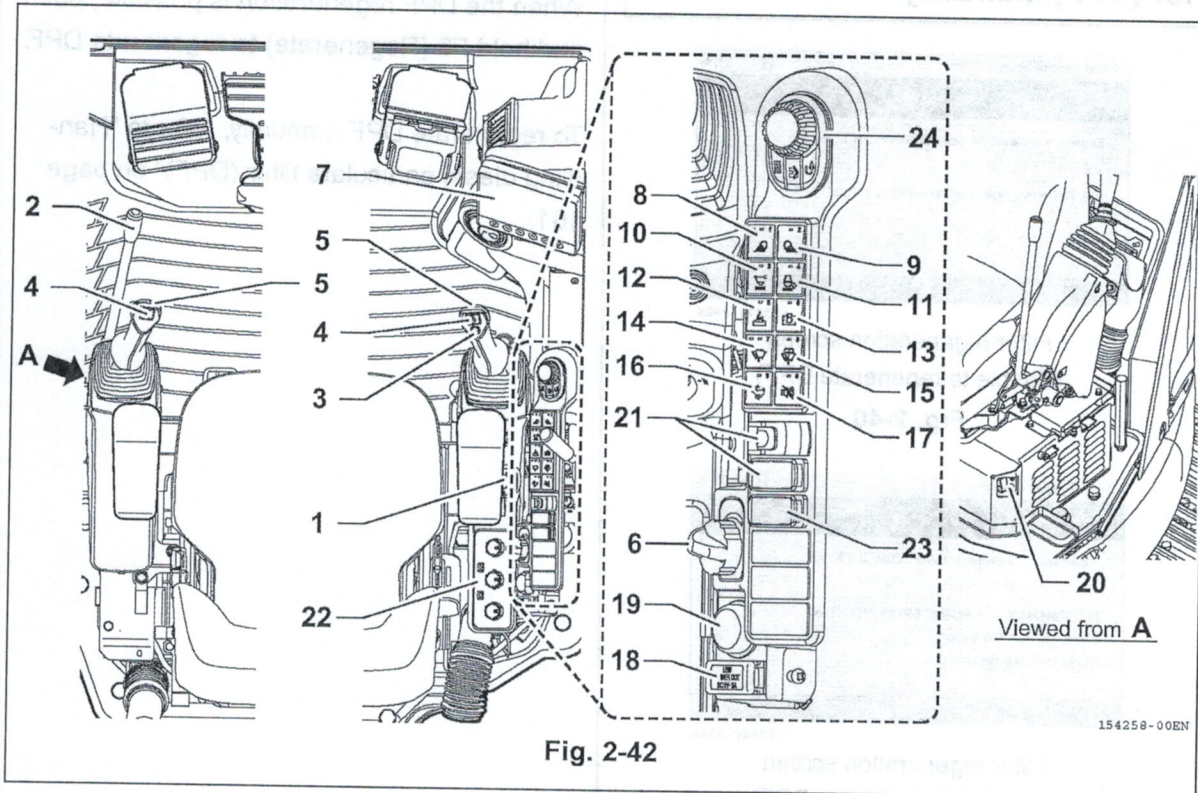

Fig. 2-42

154258-00EN

- 1: Starter switch 2: Lock lever 3: Horn switch 4: AUX operation switch
 5: AUX hold switch 6: Engine control dial 7: LCD monitor 8: Front light switch
 9: Rear light switch 10: Output mode selector switch 11: Auto deceleration switch
 12: Lifting mode switch 13: Camera image display selector switch 14: Wiper switch
 15: Washer switch 16: Travel high speed switch 17: Travel alarm stop switch
 18: USB port 19: 12 V power socket 20: Engine stop switch
 21: Quick coupler control switch 22: A/C control panel
 23: Beacon lamp (option) 24: Jog dial

1 Starter switch

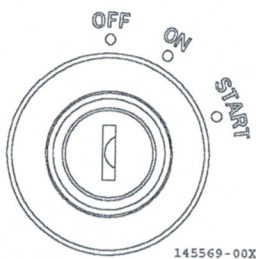

Fig. 2-43

This switch is used to start and stop the engine.

• OFF position

The key can be inserted or removed. Turning the key to this position disconnects the electrical circuit and stops the engine.

• ON position

Electric current flows to electrical switches. While the engine is running, electric current flows to the charging circuit. Keep the key in the "ON" position while the engine is running.

IMPORTANT

In cold weather, the glow plug operates for a few seconds after the starter switch is turned to the "ON" position, making engine starting easier. While the glow plug operates, the LCD monitor shows the screen indicating that the glow plug is operating. When the engine has been warmed up, the screen changes to the home screen. After confirming that the home screen is displayed, start the engine.

- START position

Turn the key to this position to start the engine. Keep the key in this position until the engine is started, and release it immediately after the engine is started. The key returns to the "ON" position.

2 Lock lever

This is a device to lock the implement operation, blade, boom swing, traveling, and swing.

⚠ WARNING

- When leaving the operator's seat, be sure to place the bucket on the ground and move lock lever to the lock position. Keep in mind that if you should touch the unlocked lever inadvertently, a serious accident could occur.
- Be sure to place the lock lever securely in the lock position. If not, it could slip out of the lock position. Thus always make sure that the lock lever is in the lock position as illustrated in the figure.
- When pulling the lock lever back, be careful not to touch the control lever. Remember that if the lock lever is not pulled back fully, the implement will not be locked.
- When pushing the lock lever forward, be careful not to touch the control lever.

IMPORTANT

The machine uses a hydraulic lock system. If the lock lever is in the lock position, the left and right control levers will operate, but all the hydraulic cylinders for the boom, arm, bucket, boom swing, blade, and AUX (option) as well as the swing motor and travel motor will not operate.

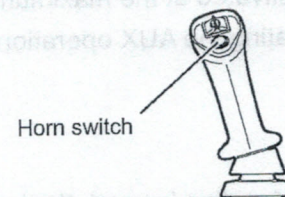
3 Horn switch

152410-00EN

Fig. 2-44

Push the switch on the top of the right control lever to sound the horn.

4 AUX operation switch

Fig. 2-45

Operate the switch on the top of the control lever to move the attachment connecting to the AUX circuit.

5 AUX operation hold switch

Fig. 2-46

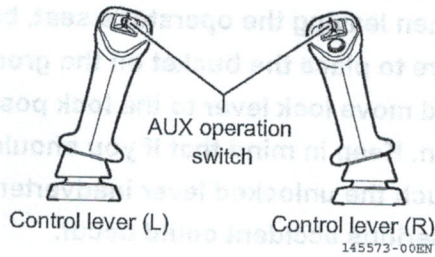
Use this switch to continuously operate the attachment connecting to the AUX circuit.

(How to use hold function)

- Operating the AUX operation switch to the left or right and operating the hold switch on the back side of the operated control lever activates the hold function.
- When the hold switch is operated without operating the AUX operation switch, the hold function is activated at the maximum flow rate for operating the AUX operation switch to the left.

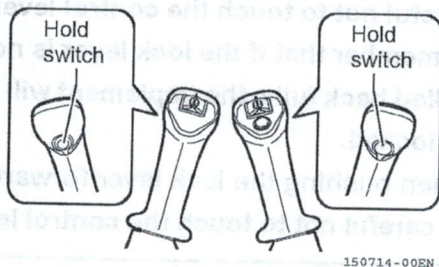
Note:

When the hold function is used, the icon using the hold function of the AUX allocation icons is highlighted on the LCD monitor.

(How to deactivate the hold function)

When the following operations are performed while the hold function is working, the hold function is deactivated.

- Operating the AUX operation switch
- Operating the AUX operation hold switch
- Turning the starter switch to "OFF"
- Raising the cutoff lever

6 Engine control dial

Fig. 2-47

This dial is used to adjust the engine speed (output).

- High idle:
Turn the dial fully in the right direction (clockwise).
- Low idle:
Turn the dial fully in the left direction (counterclockwise).

7 LCD monitor

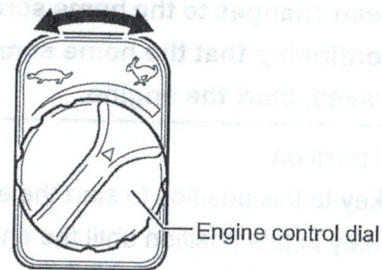
This monitor is used to display the machine status and perform the machine setting. For how to display, set, and operate the LCD monitor, refer to "LCD Monitor" on page 57.

8 Front light switch

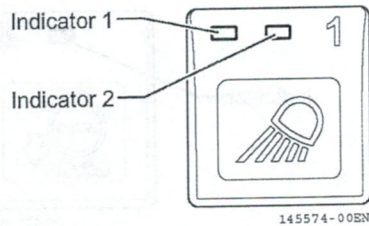

Fig. 2-48

While the key is in the "ON" position, pushing this switch turns on the front work light. The operation status of the front light can be checked by the lighting status of the indicator above the switch.

| Indicator lighting position | Front light operation status |
|-----------------------------|--|
| Indicator 1 | The boom light lights up and the LCD monitor brightness changes to the level set for when the light is on. |
| Indicator 2 | When this switch is pushed again while the boom light is lit, all the front lights light up. |
| OFF | All the front lights go off. |

For the position of the work light, refer to Section "Headlight" on page 98.

Note:

When the key is turned to the "OFF" position while the front light is lit, the front light lights up by turning the key to the "ON" position again.

9 Rear light switch (Machine equipped with rear light)

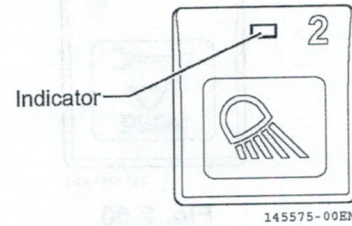

Fig. 2-49

While the key is in the "ON" position, pushing this switch turns on the rear work light. The operation status of the rear light can be checked by the lighting status of the indicator above the switch.

| Indicator lighting status | Rear light operation status |
|---------------------------|-----------------------------|
| ON | The rear light lights up. |
| OFF | The rear light goes off. |

Note:

- For machines without the rear light, pushing this switch displays a message that the function is not installed on the LCD monitor.
- When the key is turned to the "OFF" position while the rear light is lit, the rear light lights up by turning the key to the "ON" position again.

10 Output mode selector switch

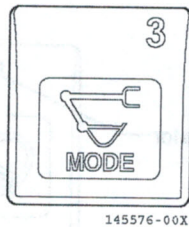

Fig. 2-50

Pushing this switch selects the output mode (ECO /NORMAL/POWER).

- **POWER mode**
When this mode is set, the POWER mode icon is displayed on the LCD monitor, and the engine speed is increased compared to that in the NORMAL mode for efficient work.
- **ECO mode**
When this mode is set, the ECO mode icon is displayed on the LCD monitor, and the engine speed is decreased compared to that in the NORMAL mode for work with low fuel consumption.

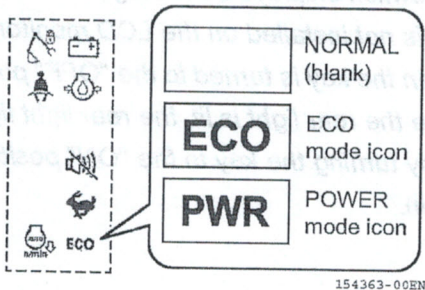

Fig. 2-51

Note:

The output mode when the key is turned to the "OFF" position is stored, and the stored output mode is set when the key is turned to the "ON" position again.

11 Auto deceleration switch

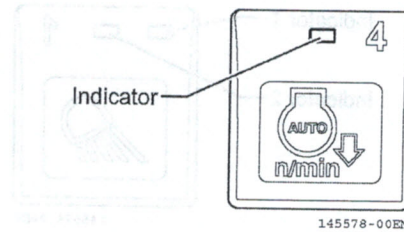

Fig. 2-52

Each time this switch is pushed, the auto deceleration function is turned ON or OFF.

| Indicator lighting status | Operating status of auto deceleration function |
|---------------------------|--|
| ON | Auto deceleration function ON |
| OFF | Auto deceleration function OFF |

Note:

- The auto deceleration function reduces the engine speed and fuel consumption when the engine power is not required. This function reduces the engine speed to low idle to reduce fuel consumption after the implement is not operated for approximately 4 seconds. Operating the implement returns the engine speed to the level set with the engine control dial.
- The auto deceleration function may not work until the hydraulic oil warms up. This phenomenon is not a fault.
- The auto decelerator function may be disabled even when turned to ON depending on the regeneration state of the diesel particulate filter (DPF). This phenomenon is not a fault.

12 Lifting mode switch

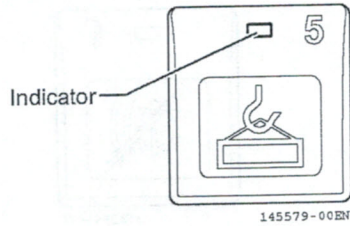

Fig. 2-53

This switch is not available.
Pushing this switch displays a message that the function is not installed on the LCD monitor.

13 Camera image display selector switch

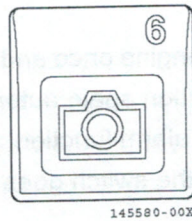

Fig. 2-54

Each time this switch is pushed, the camera image display on the LCD monitor is switched.

Note:

*While the lock lever is lowered, the camera image display cannot be turned OFF.
For switching the camera display, refer to "Camera Image Display on LCD Monitor" on page 109.*

14 Wiper switch

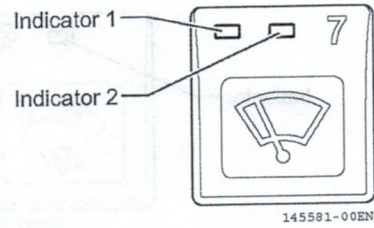

Fig. 2-55

Pushing this switch activates the wiper.
The operation status of the wiper can be checked by the lighting status of the indicator above the switch.

| Indicator lighting position | Wiper operation status |
|-----------------------------|------------------------------------|
| Indicator 1 | The wiper operates intermittently. |
| Indicator 2 | The wiper operates. |
| OFF | The wiper stops. |

Note:

While the windshield is open, the wiper does not operate.

15 Washer switch

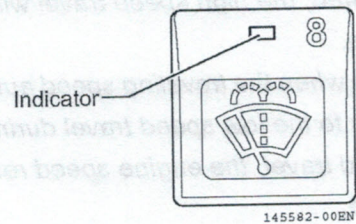

Fig. 2-56

While this switch is pushed and held, the washer operates in conjunction with the wiper.
While the switch is pushed and held, the indicator above the switch stays lit.

Note:

- *While the windshield is open, the washer does not operate.*
- *After the washer operates, the wiper operates several times.*

| Maximum 120W | Maximum 10W | Maximum 10W | Maximum 10W |
|--------------|-------------|-------------|-------------|
| 12V | 12V | 12V | 12V |
| 1.0A | 1.0A | 1.0A | 1.0A |

16 Travel high speed switch

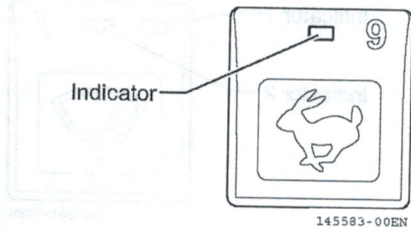

Fig. 2-57

This switch is used to select "High speed travel" for the traveling speed. It is used to switch the traveling speed between low speed and high speed. During the high speed travel, the indicator above the switch stays lit and the high speed travel icon is displayed on the LCD monitor.

Note:

- When the travel force is required on soft ground and slopes even during the high speed travel, it is not necessary to shift the switch, as it will automatically shift to the low speed travel. The indicator above the switch stays lit. When the travel force is no longer required, the high speed travel will be set again.
- Even when the traveling speed automatically shifts to the low speed travel during high speed travel, the engine speed remains the same.
- When the crane mode is selected with the high speed travel set, the traveling speed shifts to the low speed travel. This phenomenon is not a fault. When the crane mode is turned OFF, the traveling speed automatically shifts to high speed travel.

17 Travel alarm stop switch

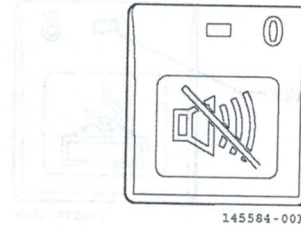

Fig. 2-58

This switch is used to temporarily stop the travel alarm operation. While the travel alarm operation is stopped, the indicator above the switch stays lit and the travel alarm function deactivation icon is displayed on the LCD monitor.

Turning off the engine once and turning the key to the "ON" position again automatically activates the travel alarm function, and the indicator lamp above the switch goes off.

18 USB port

19 12 V power socket

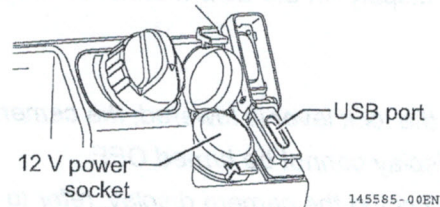

Fig. 2-59

It is the socket that can be used as a power for electronic products.

It is available when the key is in the "ON" position.

Comply with the following conditions for use.

| | USB port | 12 V power socket |
|-------------------|-------------------------------|---------------------------------|
| Voltage | 5 V | 12 V |
| Power consumption | Maximum of 10 W (2 A) or less | Maximum of 120 W (10 A) or less |

Note:

- The USB port cannot be used for charging in some connected device types.
- If an error occurs in the electrical circuit, an overcurrent flows into the USB port, which may destroy the data in the connected device. It is recommended to back up the data before connecting the device.

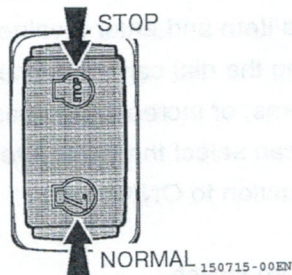
20 Engine stop switch**Fig. 2-60**

Pushing this switch to the STOP side while the engine is running stops the engine. This switch is used when the engine does not stop even when the key is in the "OFF" position due to machine failure or damage.

After stopping the engine, always return the engine stop switch to the "NORMAL" position.

- STOP : Stops the engine.
- NORMAL : Enables to start the engine.

When the switch is in the "STOP" position, the engine stop display is indicated on the LCD monitor and the engine does not start. Therefore, return it to the "NORMAL" position.

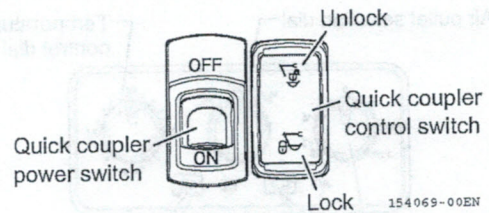
21 Quick coupler control switch**Fig. 2-61**

Turn on the quick coupler power with the quick coupler power switch and operate the quick coupler control switch to activate the quick coupler.

Pushing the quick coupler power switch to the ON side turns on the power of the quick coupler, and pushing it to the OFF side turns off the power of the quick coupler.

- Unlock: With the quick coupler power turned ON, push the quick coupler control switch to the "Unlock" side.
- Lock: With the quick coupler power turned ON, push the quick coupler control switch to the "Lock" side.

Note:

While the quick coupler power is ON, the message of "Quick coupler unlocking" is displayed on the LCD monitor, and the caution buzzer sounds.

For detailed operation method, refer to "Handling quick coupler" on page 144.

22 A/C control panel

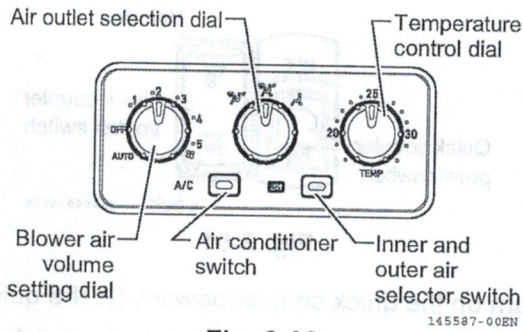

Fig. 2-62

This panel is used to operate the automatic air conditioner.

For how to operate the air conditioner, refer to "How to use air conditioner" on page 102.

23 Beacon lamp (option)

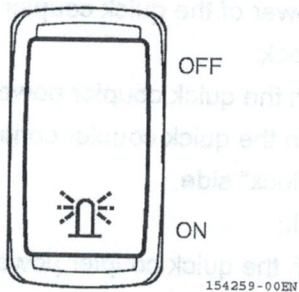

Fig. 2-63

Turning this switch on with the starter switch in the ON position will turn on the beacon lamp.

- ON : The beacon lamp lights up.
- OFF : The beacon lamp goes out.

24 Jog dial

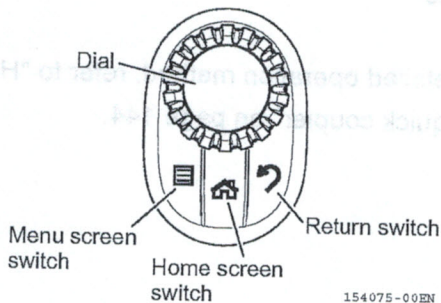

Fig. 2-64

These switches are used to remotely operate the LCD monitor.

• Dial

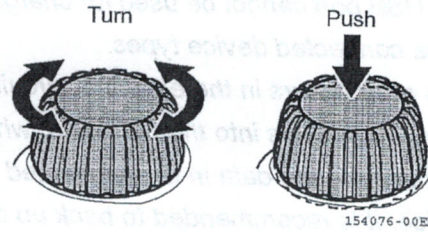

Fig. 2-65

This dial is used to move the highlight over the items on the LCD monitor, select the highlighted item and enter a value.

Turning the dial can move the highlight over the items, or increase/decrease a value. Pushing it can select the highlighted item, or turn the function to ON/OFF.

• Return switch

Pushing this switch returns to the previous screen.

• Home screen switch

Pushing this switch moves to the home screen.

• Menu screen switch

Pushing this switch moves to the menu screen.

For detailed operation method, refer to "Handling jog dial" on page 99.

Control levers and pedals

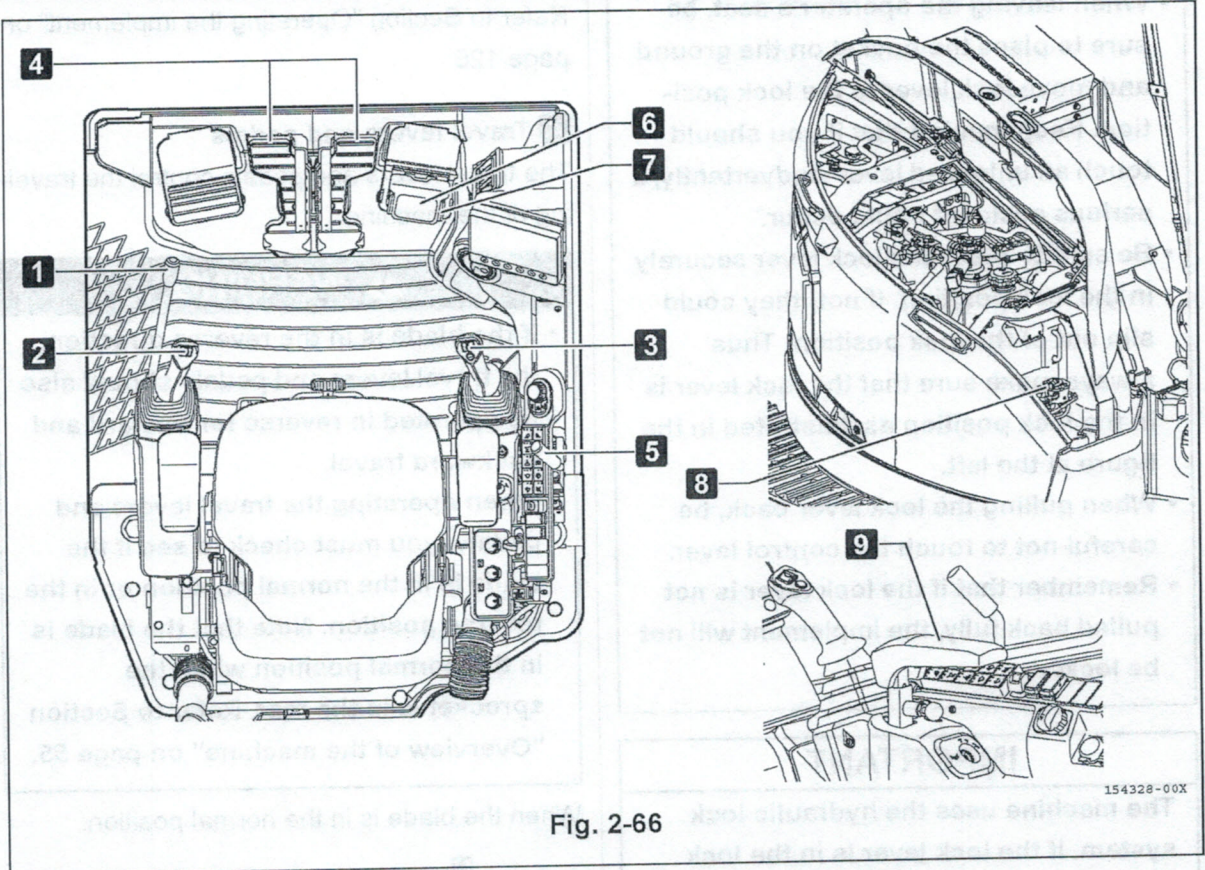

Fig. 2-66

- 1: Lock lever 2: Control lever (L) 3: Control lever (R) 4: Travel levers and pedals
 5: Blade lever 6: Boom swing operation pedal and pedal guard 7: Boom swing pedal
 8: Operating pattern change valve 9: Armrest

1 Lock lever (for the implement control levers on both sides, blade lever, boom swing pedal and the travel levers)

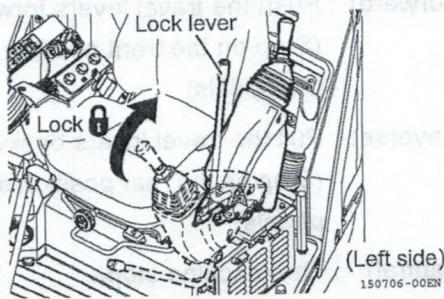

Fig. 2-67

The lock lever locks the implement control levers, blade lever, boom swing pedal and the travel levers.

⚠ WARNING

- When leaving the operator's seat, be sure to place the bucket on the ground and move lock lever to the lock position. Keep in mind that if you should touch an unlocked lever inadvertently, a serious accident could occur.
- Be sure to place the lock lever securely in the lock position. If not, they could slip out of the lock position. Thus always make sure that the lock lever is in the lock position as illustrated in the figure at the left.
- When pulling the lock lever back, be careful not to touch the control lever.
- Remember that if the lock lever is not pulled back fully, the implement will not be locked.

IMPORTANT

The machine uses the hydraulic lock system. If the lock lever is in the lock position, all the hydraulic cylinders for the boom, the arm, the bucket, the boom swing and the blade as well as the swing motor, AUX and travel will not operate although the control levers are free to move.

2 Control lever (L)

3 Control lever (R)

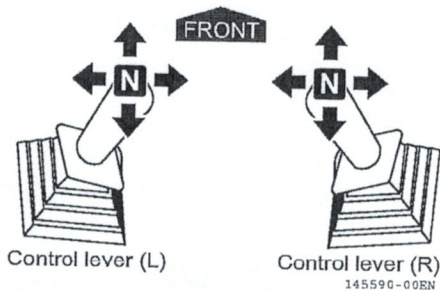

Fig. 2-68

Use these levers to control the implements and swinging of upperstructure.

Refer to Section "Operating the implement" on page 126.

4 Travel levers and pedals

The travel levers and pedals control the traveling of the machine.

⚠ WARNING

- If the blade is in the reverse direction, the travel levers and pedals should also be operated in reverse for forward and backward travel.
- When operating the travel levers and pedals, you must check to see if the blade is in the normal position or in the reverse position. Note that the blade is in the normal position when the sprocket is in the rear. Refer to Section "Overview of the machine" on page 55.

When the blade is in the normal position:

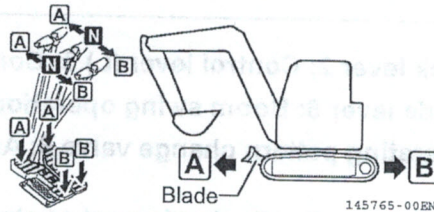

Fig. 2-69

The pedal operation is in the parenthesis.

- A** (Forward) : Push the travel levers forward.
(Step on the front position of the pedals)
- B** (Reverse) : Pull the travel levers backward.
(Step on the rear position of the pedals)
- N** (Neutral) : The machine stops.

5 Blade lever

Use this lever to control the blade.

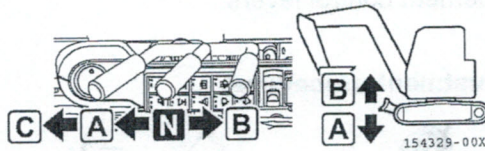

Fig. 2-70

- A** Blade down: Push the lever forward.
- B** Blade up : Pull the lever backward.
- N** Neutral : When released, the lever will return to the neutral position and the blade is held as it is.

- C** Blade float (option):
Push the lever forward to its detent position. The blade will be in the float condition and the lever is held as it is. The blade will drop to the ground by gravity and will stop. If this mode is used for operation on a concretecovered ground or landleveling operation, the bucket will follow the contour of the ground by using the weight of the blade, so the work can be performed efficiently.

6 Boom swing operation pedal and pedal guard

Fig. 2-71

The boom swing pedal has a pedal guard.

⚠ WARNING

To avoid bodily injury, securely place the pedal guard in the lock position whenever the boom swing pedal is not being operated.

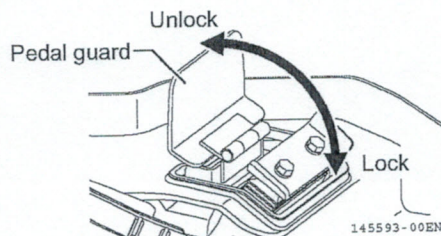
Placing the pedal guard in the lock position completely covers the boom swing pedal. To prevent misuse, always set the pedal guard in the lock position whenever the boom swing pedal is not being operated. The pedal guard can be used as a foot rest.

7 Boom swing pedal

Use this pedal to swing the boom to right and left.

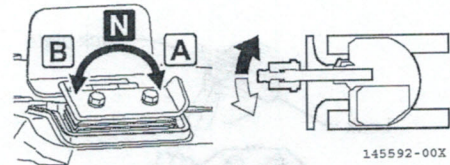

Fig. 2-72

- A** (Swing right): move to the right.
- B** (Swing left) : move to the left.
- N** (Neutral) : When released, the pedal will return to the neutral position and the boom is held as it is.

8 Operating pattern change valve

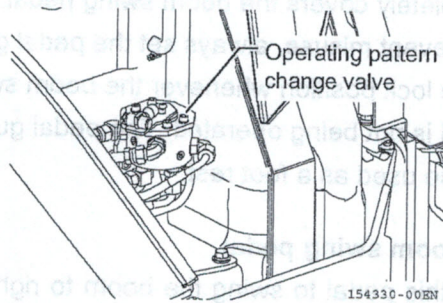

Fig. 2-73

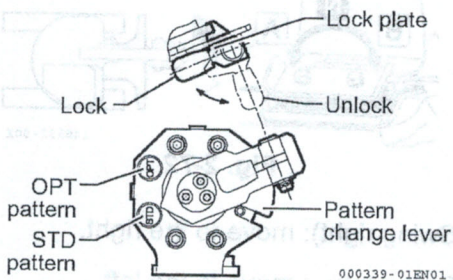

Fig. 2-74

This valve is used to switch between operating patterns for the right and left control levers. It is located inside the front cover (right).

For details of the operating patterns, refer to Section "Operating the implement" on page 126.

STD: ISO pattern

OPT: OPT pattern

1. Stop the engine and make sure the lock lever is in lock position.
2. Open the front cover (right).
3. Unlock the selector handle to move it to suit-able position.
4. Securely lock the selector handle.
5. Close the front cover (right).

IMPORTANT

Be sure to place the lock plate in the lock position.

9 Armrest

Put your arm on the armrest to operate the implement control levers.

Adjustment procedure

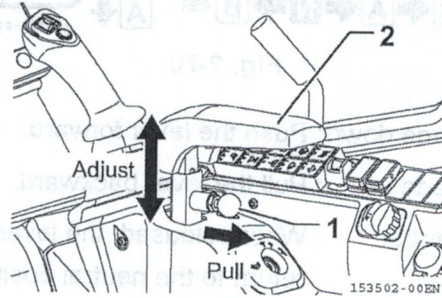

Fig. 2-75

While pulling the knob (Fig. 2-75, 1) in the direction of the arrow, adjust the armrest (Fig. 2-75, 2) to the desired height, and then return the knob (Fig. 2-75, 1) to lock the armrest. (Fig. 2-75, 2).

CAUTION

After adjusting the armrest, check that the armrest is securely locked. If the armrest is not locked, it will move during an operation, which is very dangerous.

Rear hood

⚠ WARNING

Do not open the rear hood while the engine is running. Check and service the engine after it has been stopped and temperatures have cooled.

■ Opening the rear hood

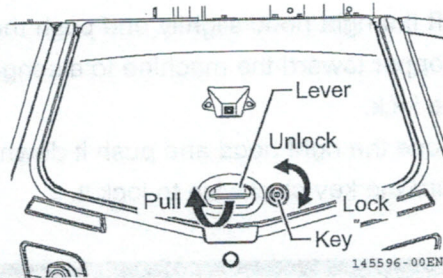

Fig. 2-76

1. Insert the starter switch key and turn it counterclockwise to unlock the rear hood.
2. Pull the rear hood lever to release the rear hood, and it will open.
3. When the rear hood is fully open, lock it in that position with the stopper rod.

■ Closing the rear hood

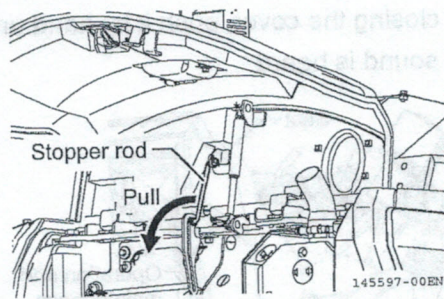

Fig. 2-77

1. Lift the rear hood slightly and pull the stopper rod to disengage it.
2. Close the rear hood and push it until it clicks shut.
3. Turn the starter switch key clockwise to lock the rear hood.

Front cover (right)

■ Opening the front cover (right)

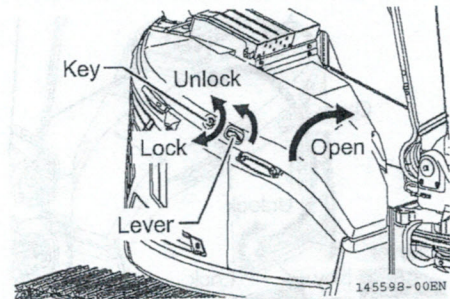

Fig. 2-78

1. Insert the starter switch key into the key hole in the front cover (right) and turn it counterclockwise to unlock the front cover (right).
2. Pull the lever to the right and open the front cover (right).
3. The front cover (right) fully opens to be locked with the stopper.

■ Closing the front cover (right)

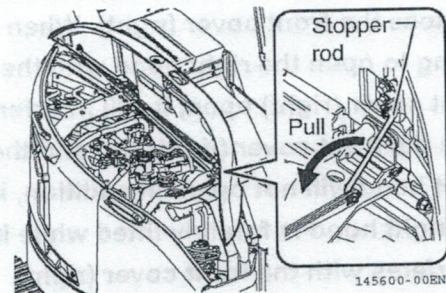

Fig. 2-79

1. Lift the front cover (right) slightly and pull the stopper to disengage it.
2. Close the front cover (right) and push it down fully until it clicks.
3. Turn the starter switch key clockwise to lock the front cover (right).

Right hood

Opening the right hood

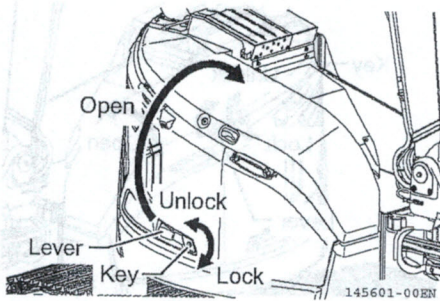

Fig. 2-80

1. Insert the starter switch key into the key hole in the right hood and turn it counter-clockwise to unlock the right hood.
2. Pull the lock lever to this side and open the right hood.
3. The right hood fully opens to be locked with the stopper.

CAUTION

When opening the right hood, be sure to close the front cover (right). When trying to open the right hood with the front cover (right) open, it will interfere with the front cover (right) rod and the right hood will not open. In addition, if the right hood is forcibly lifted while it interferes with the front cover (right) rod, the front cover (right) rod will be damaged.

Closing the right hood

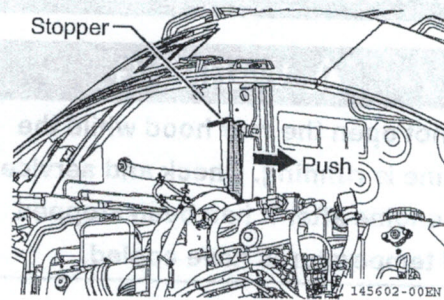

Fig. 2-81

1. Lift the right hood slightly and push the stopper toward the machine to disengage the lock.
2. Close the right hood and push it down.
3. Turn the key clockwise to lock it.

Storage compartment for the operation & maintenance manual

When you open the cover at the seat section, you will find a storage space for the operation and maintenance manual.

The partition box in the center is the storage space for the operation and maintenance manual.

When closing the cover, push it by hand until a "click" sound is heard.

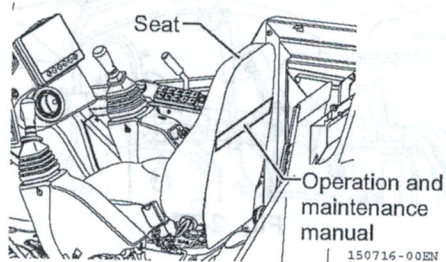

Fig. 2-82

Storage space for tools and grease gun

Storage space for tools and grease gun is located at the front of the cabin. Insert the key and turn it counterclockwise. Lock is released.

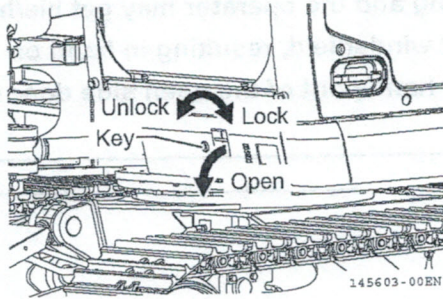

Fig. 2-83

When you open the cover at the front of the cabin, you will find a storage space for tools and grease gun.

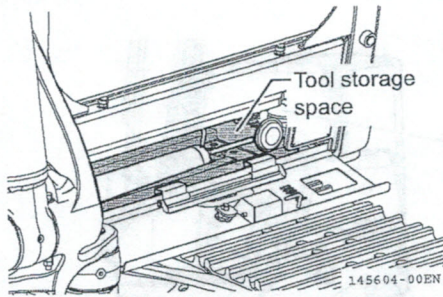

Fig. 2-84

Windshield

⚠ WARNING

When the side door or upper windshield is open, make sure that it is securely locked in place. If it is not securely locked, it may close unexpectedly due to the impact or vibrations generated while the machine is operating and the operator may get his/her hands caught in or hit his/her head on the door or windshield, resulting in hand or head injuries. In addition, do not stick the head or hands out of the open side door or upper windshield.

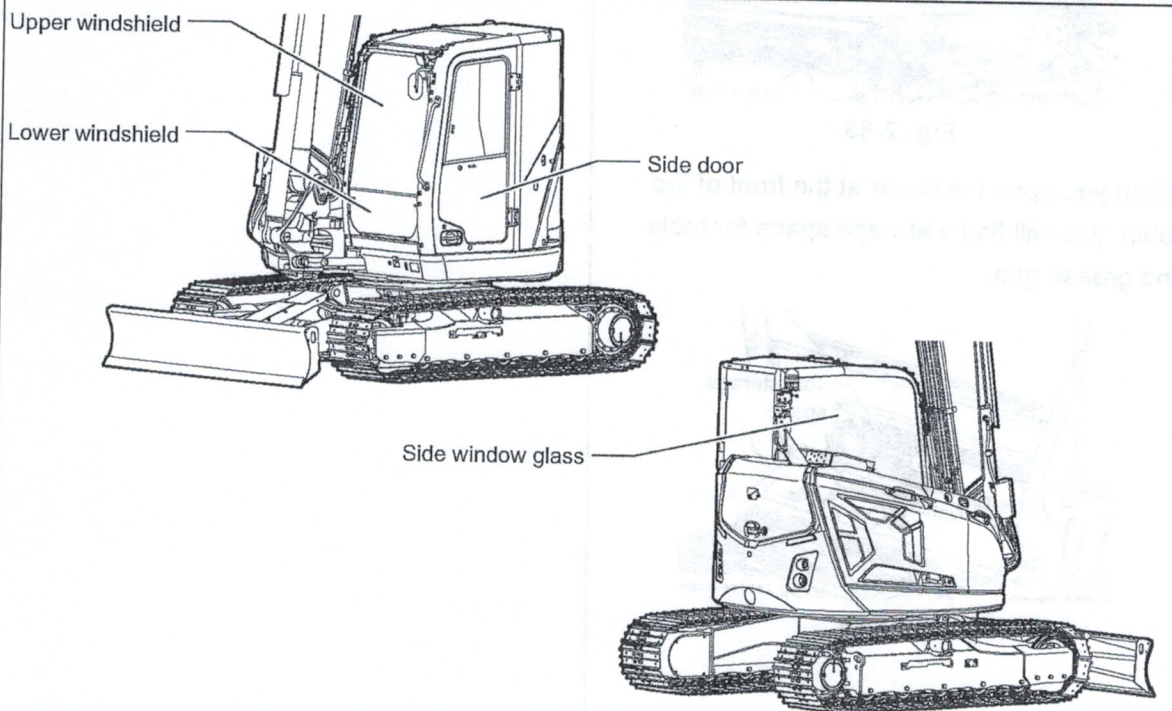

Fig. 2-85

145605-00EN

⚠ WARNING

- After opening or closing the lower windshield, always make sure that it is securely locked with the window lock levers. If it is not securely locked, it may come down unexpectedly.
- Always open or close the upper windshield by holding the right and left knobs firmly with the corresponding hands while sitting in the operator's seat. Especially, holding parts other than the knobs with the hands may cause injury to the hands, for example, from being caught in the windshield.
- Before opening or closing the upper windshield with the lower windshield stored on it, always make sure that the lower windshield is securely locked in place.

■ **Opening the upper windshield**

1. Hold the right and left knobs with the corresponding hands while sitting in the operator's seat and push the window lock lever (Fig. 2-86, A) downward to release the lock.

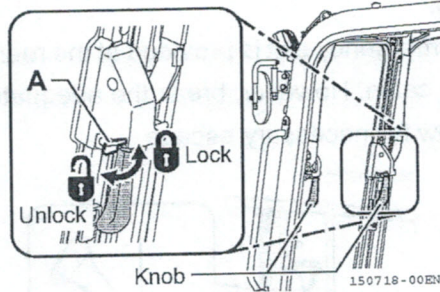

Fig. 2-86

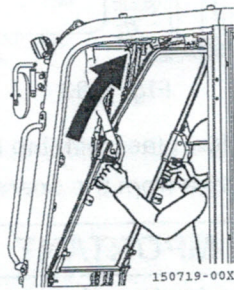

Fig. 2-87

2. After releasing the lock, slide the upper windshield up and backward while pulling it inward with both knobs until the lock (Fig. 2-88, C) on top of the upper windshield securely engages with the striker (Fig. 2-88, B) on the ceiling in the cabin.

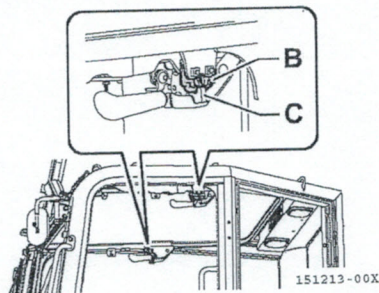

Fig. 2-88

■ **Closing the upper windshield**

1. Hold the right and left knobs with the corresponding hands while sitting in the operator's seat and push the window lock lever (Fig. 2-89, A) in to release the lock.

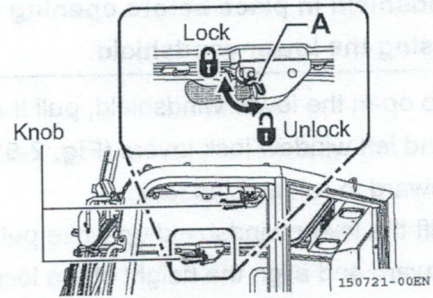

Fig. 2-89

2. After releasing the lock, hold the right and left knobs with the corresponding hands and slowly slide the upper windshield forward while pulling it downward.
3. Push the upper windshield forward with both knobs and secure it in place.

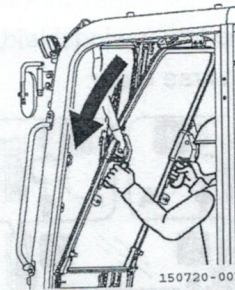

Fig. 2-90

■ Opening and closing the lower windshield

⚠ CAUTION
 Always fully close and secure the upper windshield in place before opening or closing the lower windshield.

1. To open the lower windshield, pull the right and left window lock levers (Fig. 2-91, A) inward to release the lock.
2. Lift the lower windshield up while pulling it inward and align the height of the lock pins on the lower windshield with that of the lock pin holes (Fig. 2-92, D) in the frame of the upper windshield.
3. After aligning their height, turn the window lock levers (Fig. 2-92, A) downward and insert the lock pins into the lock pin holes (Fig. 2-92, D) to secure the lower windshield.
4. To close the lower windshield, follow steps 1 to 3 in reverse order.

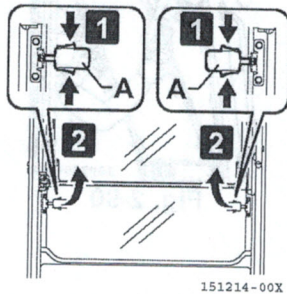

Fig. 2-91

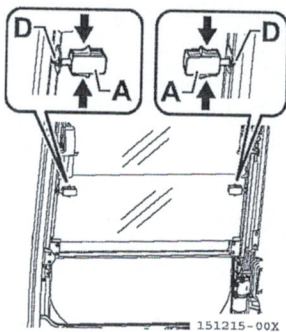

Fig. 2-92

Hammer for emergency escape from operator's cab

If the door of the cabin should not open, hammer (Fig. 2-93, 1) is provided inside the cabin to escape from the operator's cab in an emergency.

The emergency exit is provided at the rear side of the cabin. However, break the adequate window for necessary escape.

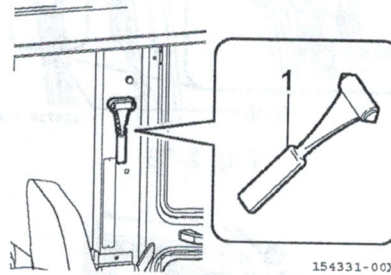

Fig. 2-93

Break the window glass with the hammer (Fig. 2-93, 1) to escape from the operator's cab.

IMPORTANT

- Remove the broken pieces of the window glass from the window frame to prevent any injury by those broken pieces.
- Watch your step not to slip on the broken pieces of the window glass which dropped around your feet.

Operator's seat

⚠ WARNING

- Be sure to adjust the seat slide to obtain the best operating position whenever you (or a new operator) starts operation.
- Do not place any foreign objects within the moving area of the operator's seat.
- Do not adjust the operator's seat while operating the machine.

Adjust the seat so that the operator can easily operate the control levers in good posture.

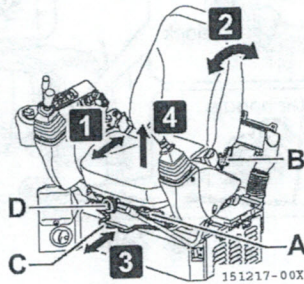

Fig. 2-94

Seat position control adjustment

1 Seat position control adjustment (forward and backward)

Pull the slide lever (Fig. 2-94, A) upward, to move the seat forward or backward. Adjust the seat to the best position for operating the control levers.

The adjustable amount of seat movement is 6.30 in. (160 mm) maximum, in 16 separate positions.

2 Seat backrest control adjustment

Pull the lever (Fig. 2-94, B) upward to adjust the backrest to the desired position.

Adjust the backrest, keeping your back in contact with the backrest or pushing the backrest with your hand, to prevent the backrest from returning suddenly.

3 Entire seat back position control adjustment (forward and backward)

Pull the slide lever (Fig. 2-94, C) upward, to move the seat forward or backward. In this case, the control levers and safety lock levers move together with the seat, so adjust to the best position for operating the travel levers and pedals. The adjustable amount of seat movement is 4.72 in. (120 mm) maximum, in 12 separate positions.

4 Weight adjustment

The weight adjustment dial (Fig. 2-95, D) is turned and it can adjust to the hardness of the bearing surface cushion with the operator's weight.

- Turn the weight adjuster dial (Fig. 2-95, D) clockwise the setting weight is increased.
- Turn the weight adjuster dial (Fig. 2-95, D) counterclockwise, the setting weight is decreased.

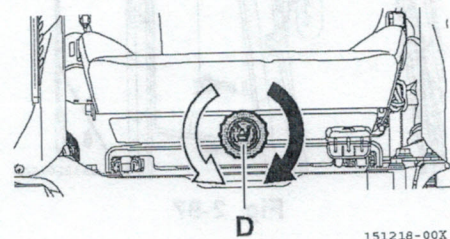

Fig. 2-95

Headlight

⚠ WARNING

The headlight gets hot when it is turned on. Do not touch it with your bare hand before it cools, to prevent burns.

The irradiation (direction) of the headlight can be adjusted. Move the light up and down to adjust the irradiation in the direction where the lighting is needed for the nighttime work.

IMPORTANT

Do not turn the cabin light excessively to prevent damage to the harness.

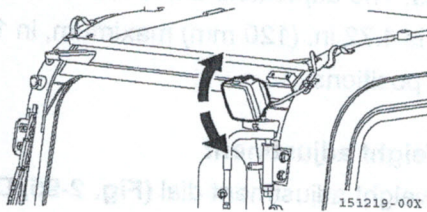

Fig. 2-96

Left window glass

Open the window on the left by sliding the glass in direction indicated.

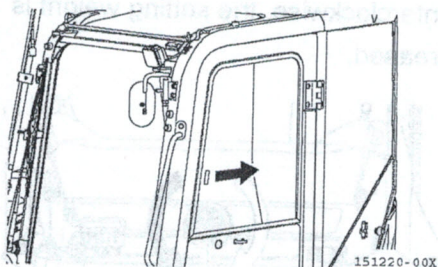

Fig. 2-97

Cabin side door

Opening and closing the cabin side door

■ From outside

1. Turn the starter switch key counterclockwise (clockwise) to unlock the side door.
2. Pull the outer handle to the side to open the side door.
3. Close the side door and turn the starter switch key clockwise (counterclockwise) to lock the side door.

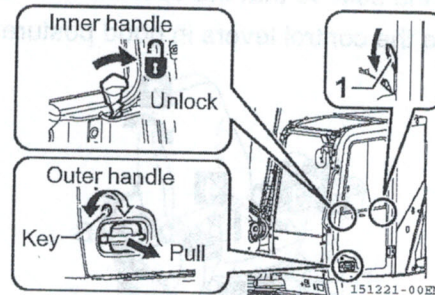

Fig. 2-98

Note:

To lock or unlock the side door with the starter switch key after using the inner handle to move the side door lock in the locked position to the unlocked position, the starter switch key must be turned in the opposite direction from the last time the key was turned.

■ From inside

1. Push the inner handle forward to open the side door.

Door lock

■ Lock the door

1. The door lock is used to hold the side door open.
2. Push the side door into the lock section to latch it open.

■ Unlock the door

1. Pull the lever (Fig. 2-98, 1) downward to unlatch the side door.

Replenishment of windshield washer fluid

The washer tank is located at the rear of the operator's seat.

If the washer fluid is insufficient, remove the clip (Fig. 2-99, 1), open the cover (Fig. 2-99, 2), remove the washer tank cap (Fig. 2-99, 3), and then add the washer fluid.

⚠ CAUTION

- When you fill the reservoir with windshield washer fluid, take care not to allow foreign matter to enter the reservoir.
- Determine the ratio of windshield washer fluid to water on the basis of the lowest past air temperature.

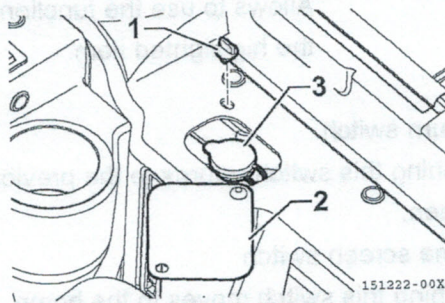

Fig. 2-99

Handling jog dial

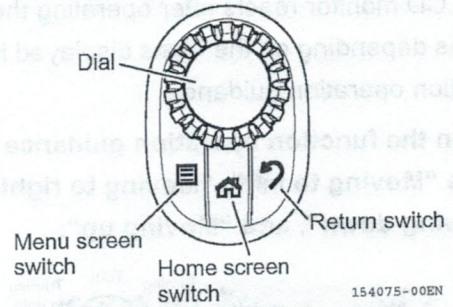

Fig. 2-100

These switches are used to remotely operate the LCD monitor.

• Dial

How the LCD monitor reacts after operating the dial varies depending on the screen displayed on the LCD monitor or the items displayed in the function operation guidance.

<Home screen>

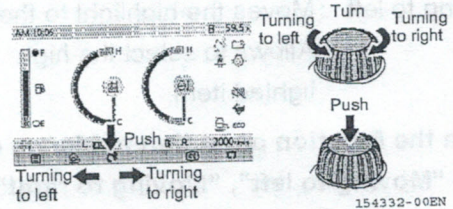

Fig. 2-101

On the home screen, the functions allocated to the function operation guidance can be selected and used by operating the dial.

Turning to right: Moves the highlight to the right in the function operation guidance.

Turning to left : Moves the highlight to the left in the function operation guidance.

Push : Allows to use the function of the highlighted item.

<Other than home screen>

On a screen other than the home screen, how the LCD monitor reacts after operating the dial varies depending on the items displayed in the function operation guidance.

When the function operation guidance contains "Moving to left", "Moving to right", "Moving down", and "Moving up":

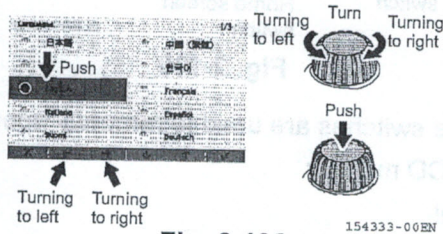

Fig. 2-102

Operations with the dial correspond to Moving to right/Moving to left on the LCD monitor, and the highlight moves accordingly.

Turning to right: Moves the highlight to the right.
 Turning to left : Moves the highlight to the left.
 Push : Allows to select the high-lighted item.

When the function operation guidance contains "Moving to left", "Moving to right", "Moving down", and "Moving up":

Operations with the dial correspond to Moving down/Moving up on the LCD monitor, and the highlight moves accordingly.

Turning to right: Moves the highlight down.
 Turning to left : Moves the highlight up.
 Push : Allows to select the high-lighted item.

When the function operation guidance contains "Moving to left", "Moving to right", "Value decrease", and "Value increase":

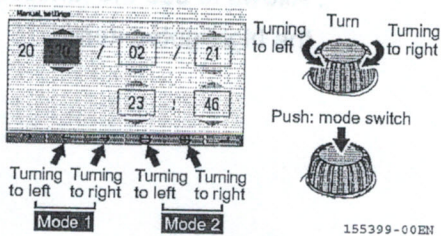

Fig. 2-103

Push the dial to switch to "Mode 1" or "Mode 2" below.

<Mode1>

Operations with the dial correspond to Moving to right/Moving to left on the LCD monitor, and the highlight moves accordingly.

Turning to right: Moves the highlight to the right.
 Turning to left : Moves the highlight to the left.

<Mode2>

Operations with the dial correspond to the value.

Turning to right: Value decreases.

Turning to left : Value increases.

Push : Mode 1/Mode 2 switch

Note:

When the highlight is at the F6 (set) position, push the dial to reflect the settings.

If the function operation guidance is not as shown above:

The functions allocated to the function operation guidance can be selected and used by operating the dial.

Turning to right: Moves the highlight to the right in the function operation guidance.

Turning to left : Moves the highlight to the left in the function operation guidance.

Push : Allows to use the function of the highlighted item.

- Return switch
Pushing this switch returns to the previous screen.
- Home screen switch
Pushing this switch moves to the home screen.
- Menu screen switch
Pushing this switch moves to the menu screen.

Handling Air Conditioner

Description of lever and switches for air conditioner

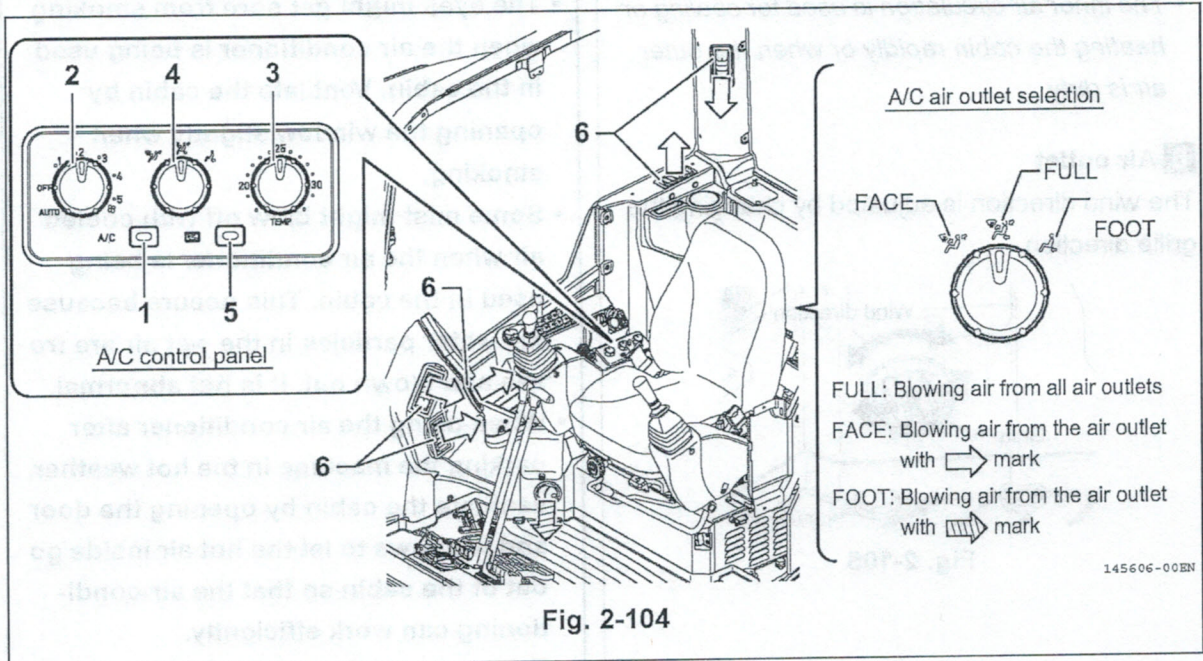

1 Air conditioner switch

Used to turn "ON" and "OFF" the air conditioner function.

The "ON" and "OFF" of the air conditioner function can be checked by the lighting status of the air conditioner switch.

- ON : Air conditioner function "ON"
- OFF : Air conditioner function "OFF"

2 Blower air volume setting dial

Used to adjust air volume.

- OFF : Stops the blower.
- AUTO : Automatically adjusts air volume.
- 1 to 5 : Selects air volume manually.

3 Temperature control dial

Temperature can be adjusted at the intervals of 1 °C from low temperature (64.4 °F (18 °C)) to high temperature (89.6 °F (32°C)).

- Turn clockwise: Increases the set temperature.
- Turn counterclockwise: Decreases the set temperature.

4 Air outlet selection dial

Used to select the air outlet for hot and cold air.

FOOT position : Blows air to foot area.

FULL position : Blows air from all air outlets.

FACE position : Blows air to windshield, face, and rear.

5 Inner and outer air selector switch

Used to select between the outer air induction (bringing outer air into the machine) and inner air circulation (cutting off outer air). The current selection of outer air induction or inner air circulation can be checked by the lighting status of the inner and outer air selector switch.

- ON : The inner air circulation is selected.
- OFF : The outer air induction is selected.

Note:

- The outer air induction is used to supply clean air from outside the cabin and to eliminate fogging from the cabin window.
- The inner air circulation is used for cooling or heating the cabin rapidly or when the outer air is dirty.

6 Air outlet

The wind direction is adjusted by changing the grille direction.

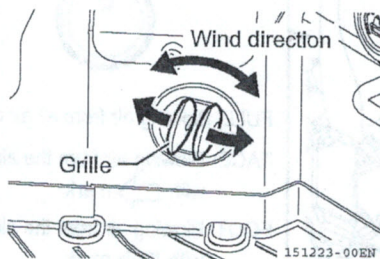

Fig. 2-105

How to use air conditioner

⚠ CAUTION

- The eyes might get sore from smoking when the air conditioner is being used in the cabin. Ventilate the cabin by opening the window slightly when smoking.
- Some mist might blow off with cooled air when the air conditioner is being used in the cabin. This occurs because the water particles in the wet air are frozen and blown out. It is not abnormal.
- When using the air conditioner after parking the machine in the hot weather, ventilate the cabin by opening the door and windows to let the hot air inside go out of the cabin so that the air-conditioning can work efficiently.
- Take care not to cool the inside of the cabin too long because it is not good for the operator's health. Control the air temperature properly.
- If the air conditioner blows no air, the air volume is too low or the cabin is not air conditioned well when the air conditioner is turned on, ask your dealer to check the air conditioner. If you keep using the air conditioner in such an abnormal state, it will cause damage to the fan motor or the compressor.
- Even in the seasons when the air conditioner is not used, operate the air conditioner for a few minutes once or twice every two or three weeks. That prevents the rotating parts such as the compressor from running out of oil, which prevents malfunction of the parts in turn.

Air conditioning

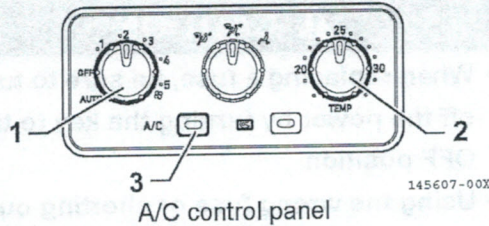

Fig. 2-106

1. Operate the blower air volume setting dial (Fig. 2-106, 1) to set the desired air volume or set it to the AUTO position.
2. Fully turn the temperature adjustment dial (Fig. 2-106, 2) counterclockwise.
3. Turn the air conditioner switch (Fig. 2-106, 3) to ON (the lamp turns on).
4. When the room gets cold, use the temperature adjustment dial (Fig. 2-106, 2) and blower air volume setting dial (Fig. 2-106, 1) to adjust to the desired room temperature.
5. Adjust the air direction with the air outlet grille.

Note:

Set the fan switch for ventilation to apply pre-load to the inside of the cabin when the air conditioner is not used, so that no dust can come into the cabin easily during operation.

IMPORTANT

Be sure to turn on the air conditioner after starting the engine to prevent excessive force to the compressor etc.

Heating

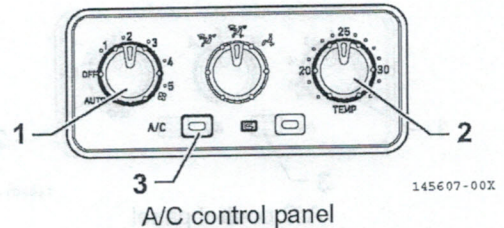

Fig. 2-107

1. Operate the blower air volume setting dial (Fig. 2-107, 1) to set the desired air volume or set it to the AUTO position.
2. Fully turn the temperature adjustment dial (Fig. 2-107, 2) clockwise.
3. Turn the air conditioner switch (Fig. 2-107, 3) to OFF (the lamp goes off).
4. When the room gets warm, use the temperature adjustment dial (Fig. 2-107, 2) and blower air volume setting dial (Fig. 2-107, 1) to adjust to the desired room temperature.
5. Adjust the air direction with the air outlet grille.

Heating for dehumidification

(In the case that the window glass tends to get fogged in rainy weather in spring or autumn.) With the heating turned on, turn the air conditioner switch (Fig. 2-107, 3) ON. (The lamp goes on.)

IMPORTANT

If the temperature inside the cabin is low, dehumidification might not work because the compressor does not operate even if the air conditioner switch 3 is turned ON.

Stop

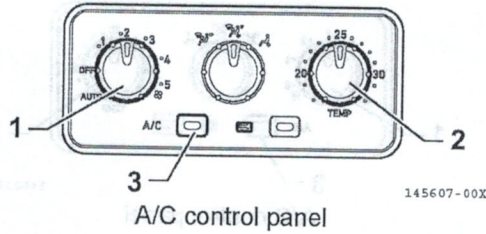

A/C control panel

Fig. 2-108

1. Turn the air conditioner switch (Fig. 2-108, 3) OFF. (The lamp goes off.)
2. Turn the blower air volume setting dial (Fig. 2-108, 1) OFF.

Note: The air conditioner also stops only by turning the blower air volume setting dial (Fig. 2-108, 1) OFF.

Fuse

CAUTION

- When replacing a fuse, be sure to turn off the power by turning the key to the OFF position.
- Using the wrong fuse or shorting out a fuse holder could damage the gauges, the electrical equipment and the wiring due to overheating.
- If a new fuse blows out immediately after replacement, there may be a problem with the electrical system. Ask your dealer for assistance.

The following two types of fuses are used in the electrical wiring circuit

Blade fuse

- Protect the electrical equipment from overcurrent which exceeds the allowable limit of the electrical equipment.
- Protect the wiring from overcurrent which exceeds the allowable limit of the wiring due to a problem with the electrical equipment.

Slow-blow fuse

- Protect the electrical equipment and the wiring from a burnout caused by overcurrent which flows in the circuit for large-capacity current when a problem occurs (such as short-circuit due to breaking of wire).

Position of the fuse

■ **Blade fuse**

Blade fuses are installed inside the fuse box (Fig. 2-110, 1) and relay box (Fig. 2-110, 2). Remove the fuse box cover (Fig. 2-110, 3) by loosening the bolt (Fig. 2-110, 5), and remove the relay box cover (Fig. 2-110, 4) by removing the two bolts (Fig. 2-110, 6).

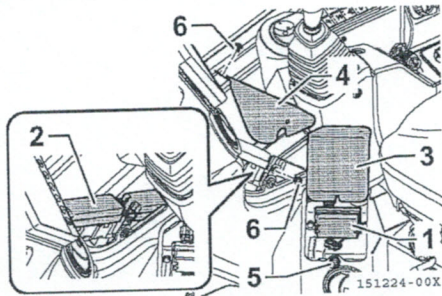

Fig. 2-109

■ **Slow-blow fuses**

Slow-blow fuses (Fig. 2-110, 1) are installed on the upper right of the battery inside the right hood.

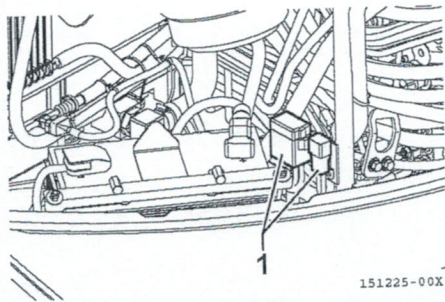

Fig. 2-110

Replacing the fuses

If the electrical equipment does not operate, the fuse may have been blown out. Follow the procedure below:

1. Turn the key to the "OFF" position and remove the - (negative) terminal of the battery.
2. Remove the fuse box cover and fuse inside.
3. If the fuse is blown out, replace it with a spare fuse of rated capacity.

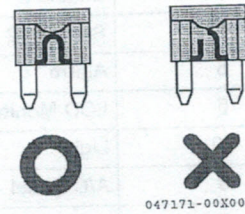

Fig. 2-111

■ **Blade fuse**

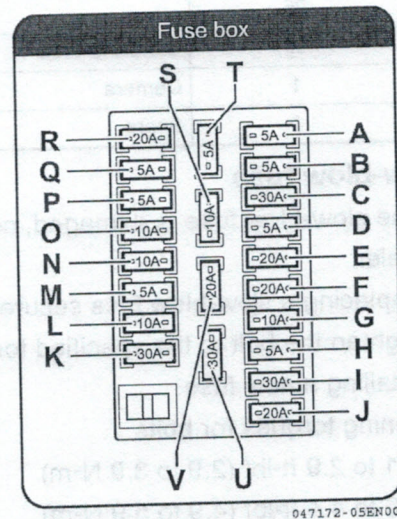

Fig. 2-112

| Symbol | Fuse capacity (A) | Circuit name |
|--------|-------------------|---------------|
| A | 20 | Power Output |
| B | 20 | Cabin-2 |
| C | 10 | Option |
| D | 5 | Security-1 |
| E | 25 | Blower |
| F | 10 | Compressor |
| G | 20 | EGR |
| H | 10 | Cabin-1 |
| I | 20 | Engine-1 |
| J | 5 | Key Switch |
| K | 20 | HYD |
| L | 10 | Engine-2 |
| M | 5 | Security-2 |
| N | 5 | Alarm |
| O | 5 | LCD Monitor |
| P | 20 | Light |
| Q | 5 | A/C Panel |
| R | 5 | Spare |
| S | 10 | |
| T | 20 | |
| U | 25 | |
| V | 10 | Surround View |
| W | 1 | Camera |
| X | 1 | Spare |

■ Slow-blow fuse

When the slow-blow fuse is damaged, contact your dealer.

When replacing a slow-blow fuse secured with a bolt, tighten the bolt to the specified torque after installing a new fuse.

• Tightening torques for bolts

M5: 2.1 to 2.9 ft•lbf (2.9 to 3.9 N•m)

M6: 3.6 to 4.4 ft•lbf (4.9 to 5.9 N•m)

Handling of Perimeter Monitoring Device (Camera Function)

The perimeter monitoring device is an auxiliary function for confirming the safety around the excavator by using cameras to monitor the rear and sides of the cabin in place of the rear view mirror and side view mirrors and displaying real-time images on the LCD monitor.

⚠ WARNING

- The perimeter monitoring device is an auxiliary function for confirming the safety around the excavator. While operating the machine, make sure to check the safety of the surroundings directly.
- The reflected range and sense of distance may differ depending on the machine posture, the surrounding conditions, and the slope of the ground.
- Objects on the screen may be closer in reality than they appear on the screen.
- There are blind spots around the machine, and some areas are not displayed on the LCD monitor.

Identification of Important Parts

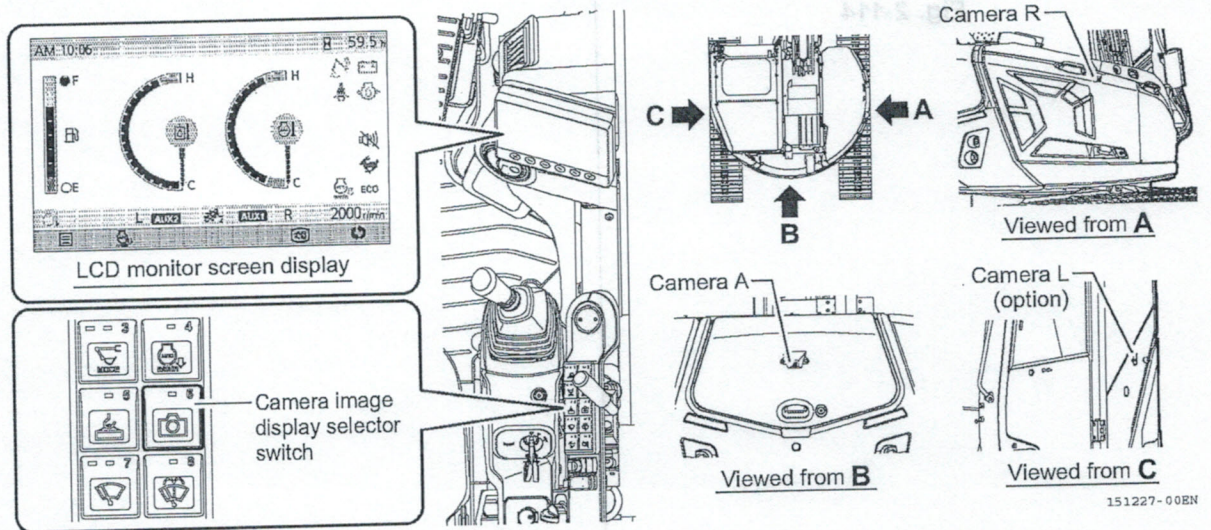

Fig. 2-113

Maintenance procedures

■ **Camera**

If the camera image is not clear, wipe off the camera lens.

Slightly dampen a soft cloth with clean water or a cleaner and clean the glass of the camera lens with the cloth.

IMPORTANT

Never use strong chemicals or abrasive cleaners.

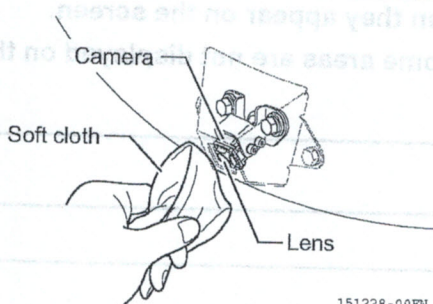

151228-00EN

Fig. 2-114



Fig. 2-113

Camera Image Display on LCD Monitor

■ Selecting the image display by operating the camera image display selector switch

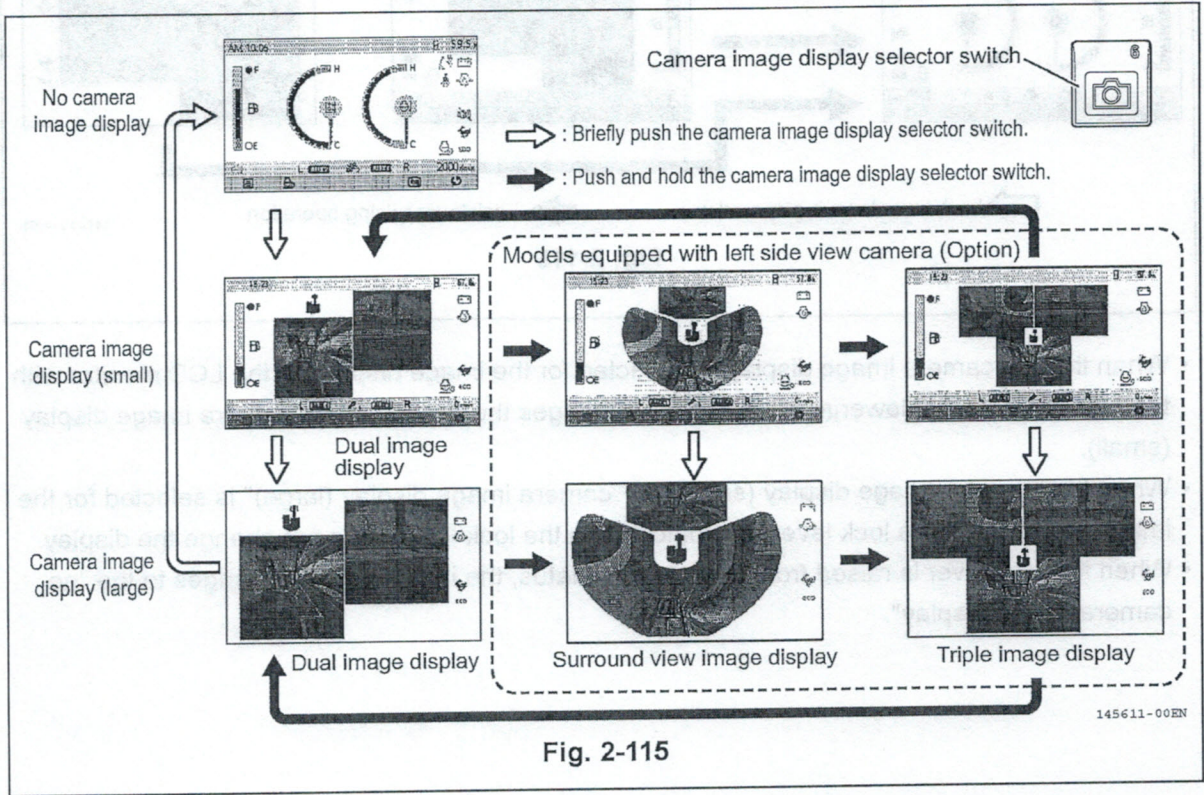

- Each time the camera image display selector switch is pushed briefly, the LCD monitor display changes to the "no camera image display", "camera image display (small)", and "camera image display (large)" in this order.

(For surround view spec. only)

- Push and hold the camera image display selector switch to change the display among "dual image display", "triple image display", and "surround view image display".

■ Selecting the camera image display by operating the lock lever

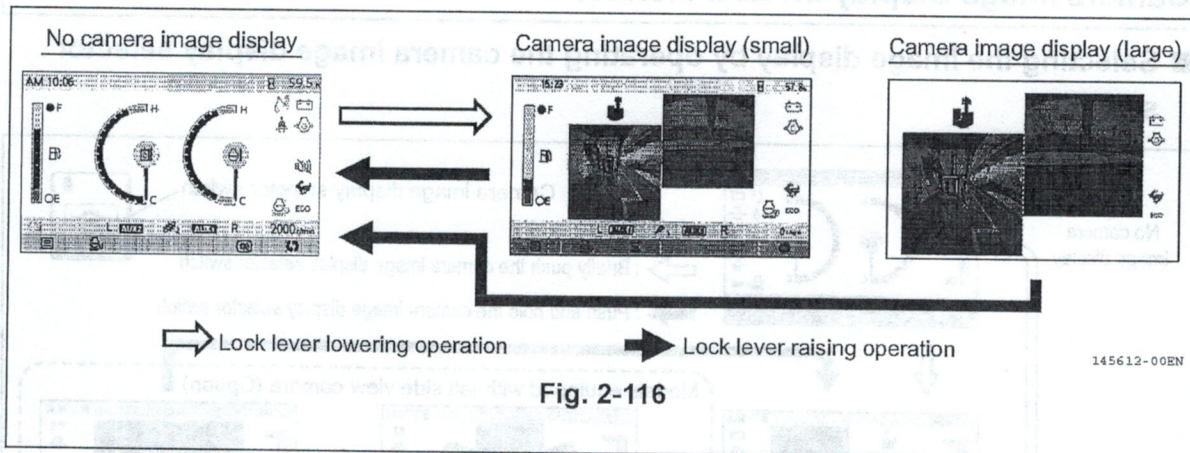

Fig. 2-116

- When the "no camera image display" is selected for the image display on the LCD monitor with the lock lever raised, lowering the lock lever changes the display to the camera image display (small).
- When the "camera image display (small)" or "camera image display (large)" is selected for the image display with the lock lever raised, lowering the lock lever does not change the display.
- When the lock lever is raised from the lowered status, the image display changes to the "no camera image display".

3. Operating Instructions

Checking before starting the engine

⚠ WARNING

- When opening the rear hood, front cover (right), and right hood for inspection, be sure to confirm that the bonnet stoppers are locked.
- If there are any combustibles in any heat build-up areas, or if there are any fuel and/or oil leaks, a fire can result. Check for possible fire causes carefully. If there is anything abnormal, be sure to take corrective action or contact your local dealer.

Before starting the engine, visually check the outside and underside of the machine as follows: Check bolts and nuts for loose connections; check the fuel, oil, and water for leaks; and also check the implement and the hydraulic system to see that they are operating properly. In addition, check the electrical wiring for loose connections and for dust deposits in the heat build-up areas. Check the following points before initial start-up for the day.

Walking check (visual inspection) around the machine

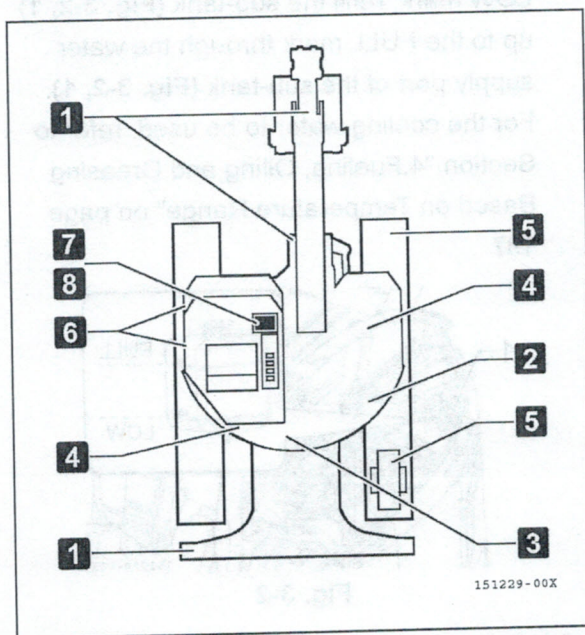

Fig. 3-1

1 Checking the implement, hydraulic cylinders, linkages, and hoses for damage, wear and loose connections

Check the implement, hydraulic cylinders, linkages, and hoses for damage, wear and loose connections. If any abnormality is found, take corrective action.

2 Removing dust deposits from around the engine, battery, and radiator

Check to confirm that there are no dust deposits or other combustibles around the engine, on the radiator, or in other heat build-up areas, such as the muffler. If there are any, remove them.

3 Checking the engine and its accessories for oil or water leakage

Check the engine for oil leakage and the cooling water system for water leakage. If oil or water leakage is found, take corrective action.

4 Checking the hydraulic system, hydraulic oil tank, hoses, and joints for oil leakage

Check for oil leakage. If oil leakage is found, take corrective action.

5 Checking the undercarriage (crawler, sprockets, and idlers) for breakage, wear, loose bolts, and oil leakage around the rollers

If any breakage or wear is found, correct it. Retighten the bolts if necessary.

If oil leakage is found, take corrective action.

6 Checking the handrails and steps for breakage and loose bolts

If any breakage is found, take corrective action. Retighten the bolts if necessary.

7 Checking the LCD monitor for breakage and loose bolts

Make sure the LCD monitor is not broken. If you find anything abnormal, contact your local dealer for repairs.

8 Checking the camera installation status

Make sure the camera is not loose. If so, attach it tightly.

Checking before start-up

Check the following points before initial start-up for the day.

■ Checking and replenishing the cooling water**⚠ WARNING**

- Do not remove the fill cap from the radiator unless supplying the cooling water.
- Check the cooling water level in the sub-tank (Fig. 3-2, 1) when the engine is cool.

1. Open the front cover (right). Then check that the cooling water level in the sub-tank (Fig. 3-2, 1) is between the FULL and LOW marks. If the water level is below the LOW mark, refill the sub-tank (Fig. 3-2, 1) up to the FULL mark through the water supply port of the sub-tank (Fig. 3-2, 1). For the cooling water to be used, refer to Section "4. Fueling, Oiling and Greasing Based on Temperature Range" on page 197

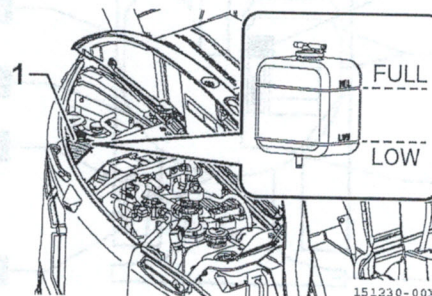

Fig. 3-2

2. After replenishing, securely tighten the cap.

3. If the sub-tank (Fig. 3-2, 1) is empty, check it for water leakage, and then, check the water level in the radiator.

If the water level is low, refill the radiator first, then refill the sub-tank (Fig. 3-2, 1).

For refilling the radiator, refer to "Replacing the engine cooling water" on page 236.

4. If the cooling water level is appropriate, close the front cover (right).

■ Checking and draining the pre-filter

⚠ WARNING

- Keep sparks flames and lit cigarettes away.
- Drain and clean the pre-filter element after engine has cooled down.
- Fuel leaked or spilled onto hot surface or electrical components could cause a fire.

IMPORTANT

If a certain amount of water is mixed into the pre-filter, the caution error (00.522329.00 Water in water separator) will be displayed on the LCD monitor. In this case, drain the pre-filter immediately.

Things to prepare

- Container for fuel waste
1. Open the right hood.
 2. Check the pre-filter to see whether the float (red ring) (Fig. 3-4, 1) has sunk down to the cup (Fig. 3-4, 2) bottom and a contamination has not mixed into the oil. If the float (Fig. 3-4, 1) has sunk down to the cup (Fig. 3-4, 2) bottom, no water has mixed into the oil; if the float (Fig. 3-4, 1) is floating in the cup (Fig. 3-4, 2), water is mixed into the oil under the float (Fig. 3-4, 1). If the water or the contamination is found in the cup (Fig. 3-4, 2), remove it as the procedure below.

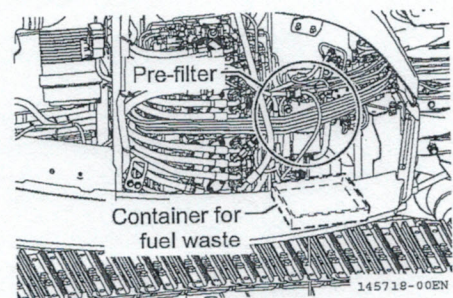

Fig. 3-3

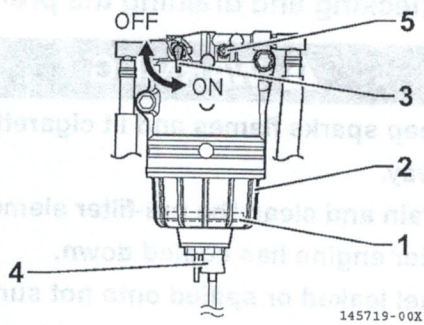

Fig. 3-4

3. Turn the fuel cock (Fig. 3-4, 3) to the OFF position.
4. Place a container receiving fuel under the hose from the drain cock (Fig. 3-4, 4).
5. Loosen the drain cock (Fig. 3-4, 4) about 4 turns, and drain the water and contamination.
If no water drips when the pre-filter drain cock (Fig. 3-4, 4) is opened, loosen the air bleeder bolt (Fig. 3-4, 5) on the top of the pre-filter by using a screwdriver to turn it counterclockwise 2 to 3 turns. After draining the pre-filter, be sure to tighten the air bleeder bolt (Fig. 3-4, 5).
6. Hand-tighten the drain cock (Fig. 3-4, 4).
7. Wipe off fuel and water adhering to the hose of the drain cock (Fig. 3-4, 4).
8. Turn the fuel cock (Fig. 3-4, 3) to the ON position.
9. After draining, release the air.
(Refer to page 227)
10. Check the fuel leak.
11. Close the right hood.



Fig. 3-5

■ Checking and replenishing the engine oil

WARNING

Immediately after stopping the engine, the engine oil, dipstick and its surroundings are very hot, and there is a risk of burns. Wait until the engine is cooled down before starting any work.

1. Open the rear hood and securely lock it in that position with the stopper rod.
2. Pick up the dipstick (Fig. 3-5, G) and wipe it with a rag to remove oil deposits.

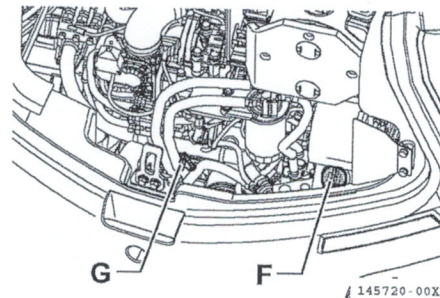

3. Fully insert the dipstick (Fig. 3-5, G) into the dipstick tube, then draw it out.
4. If the dipstick (Fig. 3-5, G) is wet above the midpoint between the H and L marks, the engine oil level is appropriate.



046127-00X00

Fig. 3-6

- If the engine oil level is below the mid-point between the H and L marks
 - 1-Open the supply port cap (Fig. 3-5, F).
 - 2-Add engine oil through the oil supply port.
 - Refer to "Fueling, Oiling and Greasing Based on Temperature Range" on page 197.
 - 3-Close the supply port cap (Fig. 3-5, F).

- If the engine oil level is above the H mark
 - 1-Remove the drain plug (Fig. 3-7, P) and drain the excessive amount of engine oil.

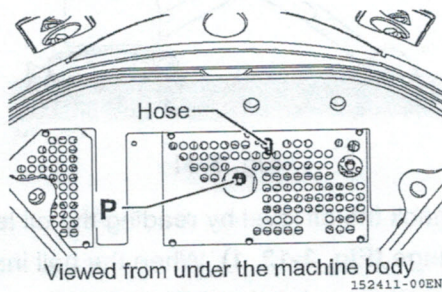

Fig. 3-7

- 2-Tighten the drain plug (Fig. 3-7, P).
 - 3-Check the engine oil level again.
5. Insert the dipstick (Fig. 3-5, G) as original.
 6. Fully close the supply port cap, and close the rear hood.

Note:

When checking the engine oil level after starting up the engine, stop the engine and allow more than 15 minutes for the engine to cool down.

If the machine is slanted, reposition the machine to ensure it is level before checking the engine oil level.

Keep in mind that the excess engine oil must not be disposed of on the ground or the road.

■ Checking and replenishing the fuel in the fuel tank

⚠ WARNING

Be careful not to overfill the fuel tank because it could cause a fire. If the tank is overfilled, completely wipe off the spilled fuel.

⚠ CAUTION

- Do not remove the strainer from the fuel supply port of the fuel tank when supplying fuel.
- Be careful not to allow any water that may be in the fuel container or dirt on the refueling equipment to enter the fuel tank.

1. When checking the fuel oil level, turn the key to the "ON" position and check the fuel meter on the LCD monitor.
LCD monitor operation: Refer to page 57.
Fuel tank capacity: 30.9 Gals. (117 L)
2. When the fuel meter pointer indicates close to E (empty), refill fuel soon.
If the message Fig. 3-8 is displayed on the LCD monitor, immediately refill fuel. At that time, approximately 6.6 Gals. (25 L) of fuel is left in the tank.



Fig. 3-8

3. Open the front cover (right) and then supply port cap (Fig. 3-9, F), and supply fuel to the fuel supply port.
4. After supplying fuel, fully close the supply port cap (Fig. 3-9, F) and close the front cover (right).

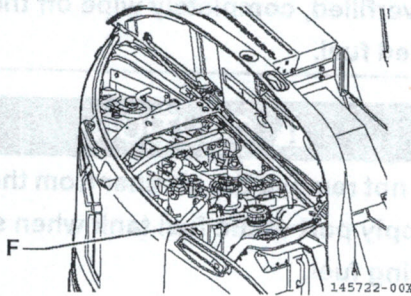

Fig. 3-9

Note:
Clogging the breather (Fig. 3-9, F) of fuel supply port cap (Fig. 3-10, 1) may cause the pressure in the fuel tank to decrease, resulting in stoppage of fuel supply to the engine. If the fuel supply port cap is contaminated, clean the cap.

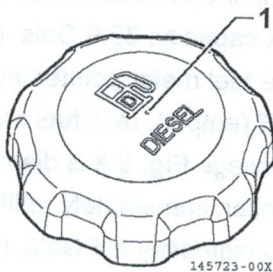

Fig. 3-10

■ Checking and replenishing the hydraulic oil tank

⚠ WARNING

When removing the plug of the oil supply port, slowly loosen it to gradually relieve the internal pressure in the tank, or oil may spurt from the tank.

1. Retract the arm and bucket cylinders and lower the boom until the bucket teeth and blade contact the ground, and stop the engine.

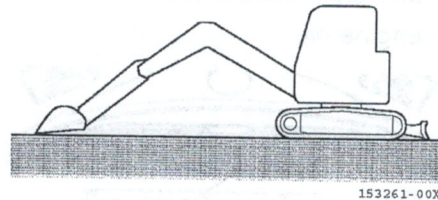

Fig. 3-11

2. Check the oil level by reading the oil level gauge (Fig. 3-12, 1). When the ball inside the gauge is located 0.79 in. (20 mm) above the midpoint between the upper and lower limit marks, the oil level is appropriate.

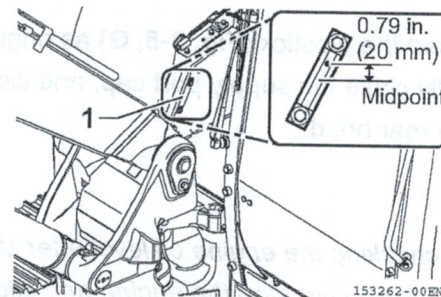

Fig. 3-12

3. If the ball is located below the midpoint, open the front cover (right) and then the supply port cap (Fig. 3-13, F) using a tool with a width across flats of 1.18 in. (30 mm), and refill the hydraulic oil. For the quality of the oil to be used, refer to "Fueling, Oiling and Greasing Based on Temperature Range" on page 197.

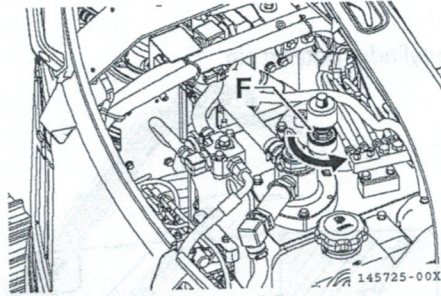

Fig. 3-13

Note:

Note that the oil level varies with the oil temperature.

When reading the oil level, follow these guidelines:

- Appropriate level: Around 0.79 in. (20 mm) above the midpoint of the level gauge [oil temperature: 50 to 86 °F (10 to 30 °C)].
- During normal operation, the oil level gauge should read at the upper limit mark of the gauge scale [oil temperature: 122 to 176 °F (50 to 80 °C)]

IMPORTANT

At the oil temperature of 50 to 86 °F (10 to 30 °C), do not refill more than the upper limit of the oil level gauge. An excessive amount of hydraulic oil may damage the hydraulic system by placing stress on its components, causing a dangerous high-pressure leak.

4. Clean the threaded section of the supply port cap, and check the O-ring. If any flaw is found on the O-ring, replace it with a new one.
O-ring (Part number: 24311-000380)
5. Close the supply port cap and then the front cover (right).

■ **Greasing**

IMPORTANT

Grease the fittings thoroughly after washing the machine or after operation in rain, on soft ground, or in muddy water.

1. Put the bucket and the blade on the ground and stop the engine.

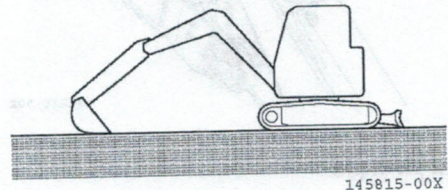
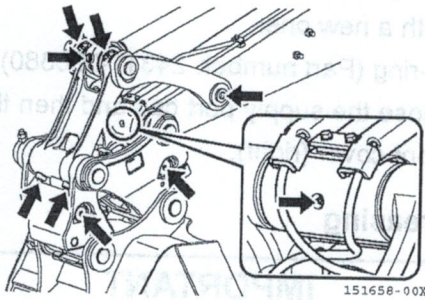

Fig. 3-14

2. Clean the grease nipples indicated by arrows in the following figures and grease them with a grease gun.
3. After greasing, wipe off any excess that remains.

Bucket pin
Quick coupler
Around bucket link



Bucket cylinder bottom pin
Arm cylinder rod pin

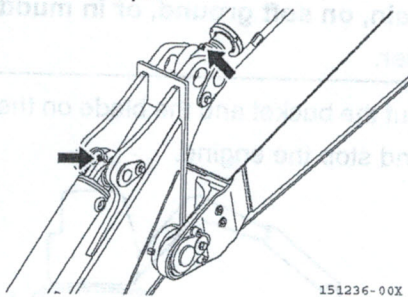

Arm pivot pin

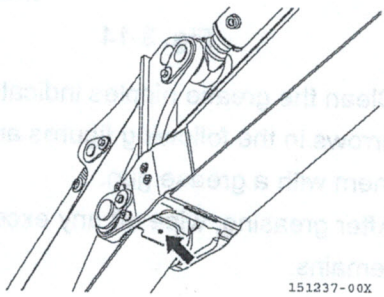
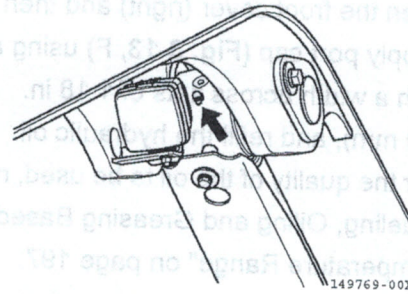
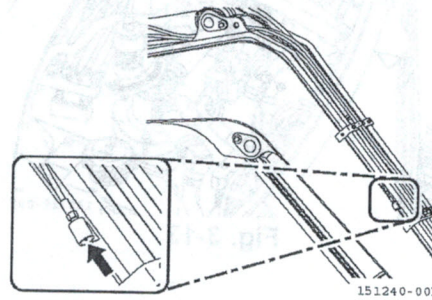

Fig. 3-15

Boom cylinder rod pin



Arm cylinder bottom pin



Boom cylinder bottom pin
Swing cylinder rod pin

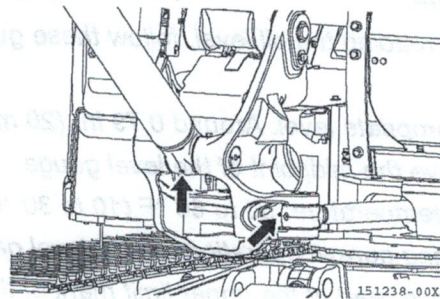

Boom pivot pin
Boom bracket pivot pin

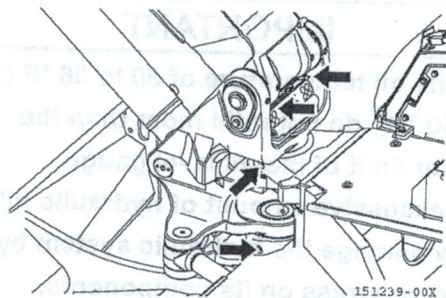

Fig. 3-16

■ **Checking the electrical equipment**

⚠ CAUTION

If a fuse blows out frequently, contact your dealer for assistance.

Check fuses for damage, wiring for poor connections or short circuits, and battery terminals for corrosion or loose fits. Take corrective action.

Check the following items after the key is turned to the "ON" position.

Note:

This machine uses a maintenance-free battery (sealed type). Inspection or refilling of battery electrode is not necessary.

● **Check the monitor functions.**

Check the functions of LCD monitor (hour meter, water temp. meter and fuel meter).

● **Check the camera image indication.**

Make sure that the camera image is displayed on the LCD monitor, and if the camera image is not displayed properly, contact your local dealer for repairs.

● **Check that all switches function correctly and all lamps light correctly.**

- Check the work lights.
- Check the horn.
- Check the auto deceleration function.
- Check the eco mode function.
- Check the wiper function.
- Check the room lamp for lighting.
- Check the air conditioner function

● **Check the travel alarm function.**

- To check the travel alarm function, push or pull the travel levers after the lock lever have been unlocked.

Operating and checking instructions before starting up the engine

⚠ WARNING

- **Accidentally operating a control lever can cause the machine to move suddenly, possibly causing a serious accident.**
- **When leaving the operator's seat, be sure to place the lock lever securely in the lock position.**

1. Check that the lock lever (Fig. 3-17, 1) is in the lock position.

Note:

When the lock lever (Fig. 3-17, 1) is in the unlock position, the engine cannot be started. To start the engine, ensure to set the lock lever (Fig. 3-17, 1) to the lock position.

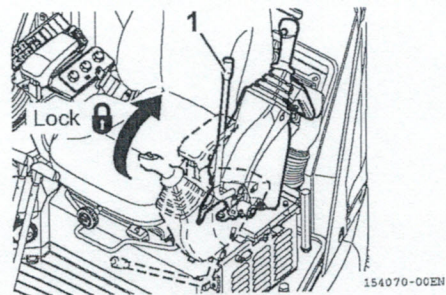

Fig. 3-17

2. Check that the control levers and control pedals are at the neutral position.
3. Fasten the seatbelt snugly.

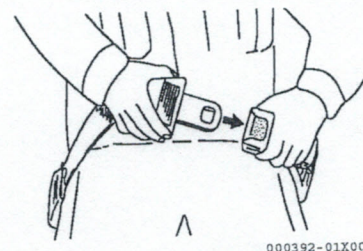

Fig. 3-18

4. Insert the key into the starter switch and set it to the "ON" position. Then check the following points:

The warning buzzer sounds and the opening screen appears on the LCD monitor. If nothing is displayed on the LCD monitor, or the warning buzzer does not sound, an error in the circuit is suspected. Ask your dealer to repair.

5. Turn the light switch to "ON", and check that the boom light and cabin light come on. If any of them does not come on, an error in the circuit is suspected. In this event, ask your dealer for repair.

Starting up the engine

⚠ WARNING

- **First check that there are no people or obstacles around the machine.**
Then sound the horn and start the engine.
- **Be sure that you are seated on the operator's seat when starting the engine.**
- **When starting the engine in an enclosed place, be sure that there is adequate ventilation so that the exhaust gases can escape.**

Normal start-up

1. Turn the engine control dial to around the midpoint.
2. Set the starter switch key in the starter switch to the "START" position. The engine will start.
3. After the engine has started, release the starter switch key.
The starter switch key will return to the "ON" position by itself.

Note:

- *Turning the key rapidly from "OFF" to "START" position may cause a slow operation when starting the engine.*
- *When the engine is warm, the engine can start up even if the accelerator lever is left in the "Low idle" position.*

IMPORTANT

To protect the starter motor and the battery:

- Do not keep the key in the "START" position for more than 10 seconds.
- If the engine fails to start, do not attempt to start the engine immediately again, but set the key to the "OFF" position and wait for approximately 30 seconds, then start the engine again.

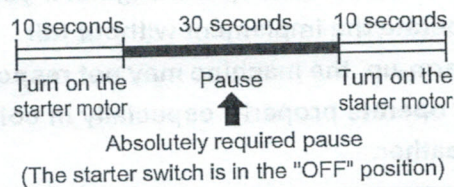
**Fig. 3-19****Starting the engine in cold weather**

To start the engine when the outside air temperature is low, follow the steps below:

1. Turn the engine control dial to around the midpoint.
2. Turn the key in the starter switch to the "ON" position and hold it in the position. The LCD monitor shows the screen indicating that the glow plug is operating. When the engine is warmed up, the screen changes to the home screen. After confirming that the home screen is displayed, start the engine.



Glow plugs activated. Please wait.

145407-00EN

Fig. 3-20

3. Turn the starter switch key in the starter switch to the "START" position to start the engine.
4. After the engine has started, release the starter switch key. The starter switch key will return to the "ON" position by itself.
5. When the engine speed has increased, turn the engine control dial fully to the left to set the engine speed to low idle.

IMPORTANT

To protect the starter motor and the battery:

- Do not keep the key in the "START" position for more than 10 seconds.
- If the engine fails to start, do not start the engine immediately again, but set the key to the "OFF" position and wait for approximately 30 seconds, then start the engine again.
- Traveling or operating the machine without adequate warming in cold weather may adversely affect the machine performance.

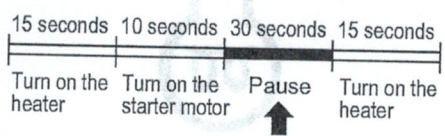

Absolutely required pause
000402-01EN00

Fig. 3-21

Operating and checking instructions after starting the engine

⚠ WARNING

- Emergency stop.
If abnormal operation occurs, turn the key to the "OFF" position, to shut off the electrical system and the engine. Then ask your dealer to check the machine.
- Be sure to warm up the engine. If you operate the implement without full warm-up, the machine may not respond or operate properly, especially in cold weather.

IMPORTANT

- The proper hydraulic oil temperature is between 122 °F and 176 °F (50 °C and 80 °C).
If you have to operate the machine at a low hydraulic oil temperature, increase the hydraulic oil temperature to about 68 °F (20 °C) before operating the implement.
- In the event that you have to operate any control lever at a temperature lower than 68 °F (20 °C), operate it gently.
- Do not accelerate the engine rapidly until the engine warms up.

After starting the engine, do not start operating the machine immediately but follow this procedure:

1. Check that no warning is displayed in the warning display area (Fig. 3-22, 1) on the LCD monitor, and that the engine oil pressure icon and battery charge icon are not displayed in the icon display area (Fig. 3-22, 2).

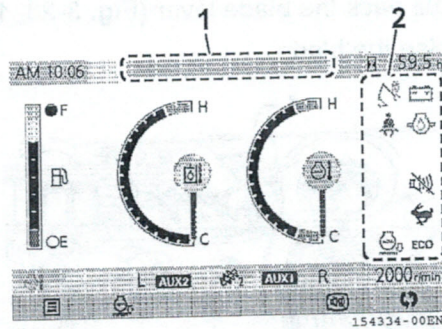

Fig. 3-22

2. Turn the engine control dial to the midpoint between the Low idle and High idle position, and run the engine with no load at medium speed for approximately five minutes.
3. Unlock the lock lever, and lift the bucket from the ground.
4. Operate the bucket and arm control levers slowly to move the bucket and arm cylinders to their stroke ends.
5. Operate the bucket for 30 seconds and the arm for 30 seconds alternately for approximately five minutes.
Warm up the engine until the hydraulic oil temperature reaches or exceeds 122 °F (50 °C) (approx. 1/4 of the hydraulic oil temperature gauge display).

IMPORTANT

When moving the implement, be careful not to bump it against the machine or the ground.

6. Check the exhaust gas color, the machine noise, and the vibration level for abnormality. If something is abnormal, take corrective action.

Note:

- White smoke may be emitted from the exhaust pipe due to water vapor accumulation shortly after the engine starts but will normally disappear once the engine has warmed up.

- Because the engine of this model is furnished with a DPF, exhaust odor is different from that of conventional diesel engines.

7. Set the lock lever to the "LOCK" position to confirm that the implement cannot be operated and the upperstructure cannot be swung with the left and right control levers.
8. Unlock the lock lever and operate the control levers to check that the implement can be operated and the upperstructure can be swung normally. If something is abnormal, take corrective action.
9. While swinging, return the implement control lever to the neutral to check that the swing brake operates normally. If something is abnormal, take corrective action.
10. Check that no abnormal noise is heard from the hydraulic equipment. If any abnormal noise is heard, take corrective action.

Ask your dealer to resolve any problems identified in steps 1 to 10 above.

Starting and stopping the machine

Forward/backward/stop

⚠ WARNING

- Always check the position of the blade before operating the travel levers and pedals.
- When the blade is in the rear, the travel levers and pedals operate in reverse of normal operation.
- A signal person should be in attendance to give signals at sites which are dangerous or not clearly in view of the operator.
- Clear all people from the working area.
- Sound the horn before beginning travel, to alert the people near the machine.
- Clear obstacles from the path of the machine.
- Do not operate the travel levers rapidly while the engine is running at high speed. Otherwise, the machine may start suddenly, causing a serious accident. Operate the travel levers slowly.

⚠ CAUTION

- Check the current travel mode before starting a traveling operation.
- Do not stop the machine suddenly, but try to stop with a safety margin.

1. Turn the engine control dial fully to the right to increase the engine speed.
2. Unlock the lock lever, and retract the implement to raise it 16 to 20 in. (40 to 50 cm) above the ground.

3. Pull back the blade lever (Fig. 3-23, 1) to raise the blade.

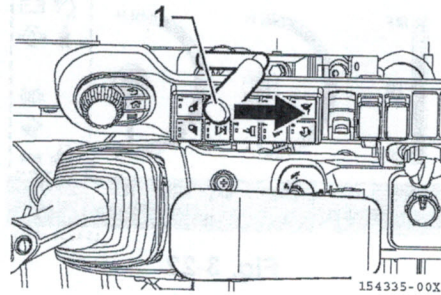

Fig. 3-23

4. Operate the left and right travel levers (Fig. 3-24, 2) or pedals (Fig. 3-24, 3) as follows:

- When the blade is in the front of the machine:
 - Operating the travel lever (Fig. 3-24, 2) or travel pedal (Fig. 3-24, 3) forward moves the machine forward, and operating backward moves the machine backward.

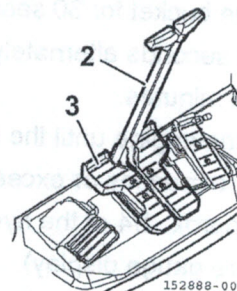

Fig. 3-24

- When the blade is in the rear of the machine:
 - Operating the travel lever (Fig. 3-24, 2) or travel pedal (Fig. 3-24, 3) backward moves the machine forward, and operating forward moves the machine backward.

5. Returning the travel lever (Fig. 3-24, 2) or travel pedal (Fig. 3-24, 3) to the neutral position stops traveling.

Steering

Steering (turning the machine)

⚠ WARNING

Always check the position of the blade before operating the travel levers.

When the blade is in the rear, the travel levers operate in reverse of normal operation.

Do not use the travel pedals to steer the machine, or the machine may not be controlled expectedly, causing a serious accident.

To steer the machine, operate the travel levers only.

Do not turn the machine too sharply. Before spin-turning, always stop the machine first.

Operate the two travel levers as follows:

■ Steering the machine when it is not traveling

To turn left, push the right travel lever forward and start traveling forward to the left. Pull the right travel lever back and start traveling in reverse to the left.

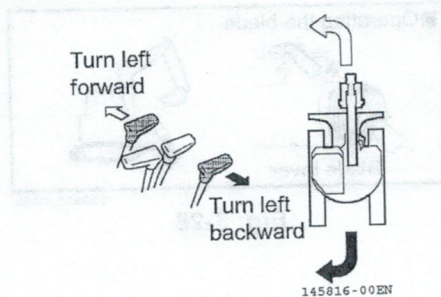

Fig. 3-25

Note:

To turn right, operate the left travel lever in the same manner as above.

■ Steering the machine while traveling (the left and right travel levers are both tilted in the same direction)

To turn left, return the left travel lever to the neutral position.

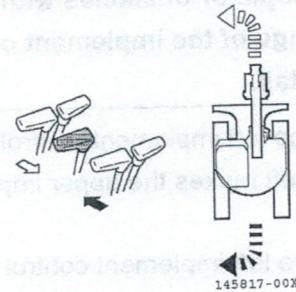

Fig. 3-26

Note:

To turn right, return the right travel lever to the neutral position.

■ Spin-turning the machine when it is not traveling

To spin-turn left, push the right travel lever forward while pulling the left travel lever back.

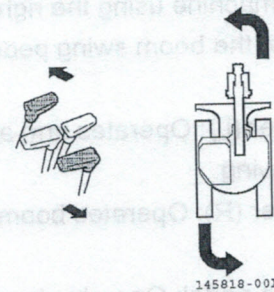

Fig. 3-27

Note:

To spin-turn right, push the left travel lever forward while pulling the right travel lever back.

Swinging the upperstructure

⚠ WARNING

Before swinging, make sure that there are no people or obstacles within the swing range of the implement or the machine tail.

Operating the left implement control lever to the right or left makes the upper implement swing.

Returning the left implement control lever to the neutral activates the swing brake to stop swinging.

Operating the implement

⚠ WARNING

Check the area around the machine for safety and sound the horn before beginning to operate the machine.

Operate the machine using the right and left control levers, the boom swing pedal and the blade lever.

- Control lever (L): Operates arm and upperstructure swing.
- Control lever (R): Operates boom and bucket.
- Boom swing pedal: Operates boom swing.
- Blade lever: Operates blade.

The relationships between the operation of the control levers, the boom swing pedal and the movement of the implement are shown in the illustrations on Fig. 3-28.

On releasing the control levers and the boom swing pedal, they will return to their neutral positions and the implement will stop moving.

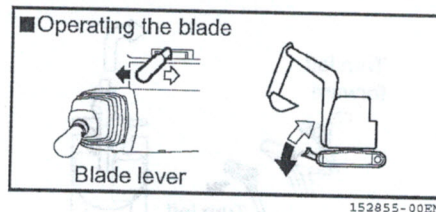
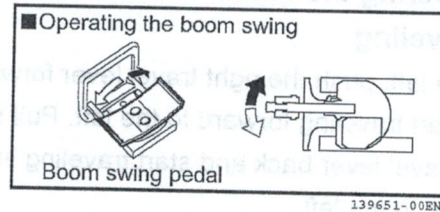
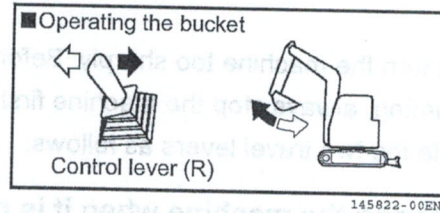
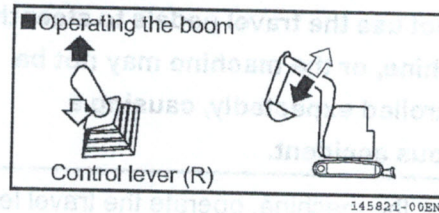
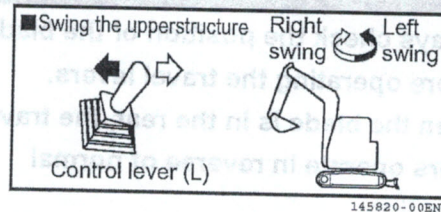
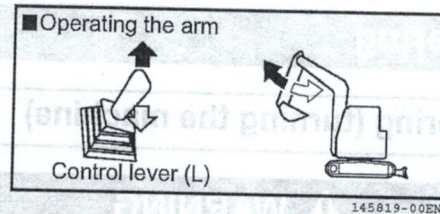

Fig. 3-28

With Operating pattern change valve

⚠ WARNING

- Check the area around the machine for safety and sound the horn before beginning to operate the machine.
- According to the switching of pattern change lever, control lever operation can be chosen in two patterns.
- To prevent accidental injury, never operate Excavator before confirming location of pattern change lever.

Operate the machine using the right and left control levers, the boom swing pedal and the blade lever.

<STD Pattern>

- Control lever (L): Operates arm and upper-structure swing.
- Control lever (R): Operates boom and bucket.

<OPT Pattern>

- Control lever (L): Operates boom and upper-structure swing.
- Control lever (R): Operates arm and bucket.
- Boom swing pedal: Operates boom swing.
- Blade lever: Operates blade.

The relation between the operation of the levers and the boom swing pedal, and the movement of the implement are shown in the illustrations on the right.

On releasing the levers and the boom swing pedal, they return to the neutral position and the implement will stop as they are.

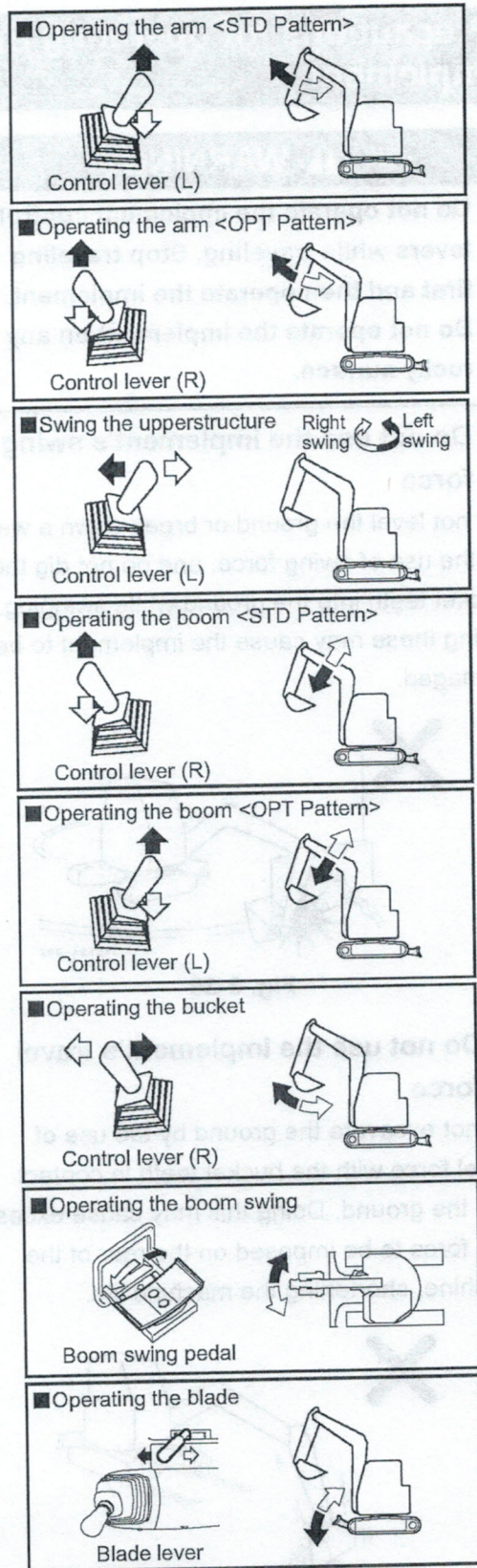

Fig. 3-29

15 4357-00EN

Precautions for operating the implement

⚠ WARNING

- Do not operate the implement control levers while traveling. Stop traveling first and then operate the implement.
- Do not operate the implement on any rocky surface.

■ Do not use the implement's swing force

Do not level the ground or break down a wall by the use of swing force, and do not dig the bucket teeth into the ground while swinging. Doing these may cause the implement to be damaged.

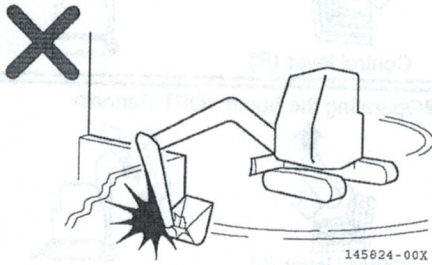

Fig. 3-30

■ Do not use the implement's travel force

Do not excavate the ground by the use of travel force with the bucket teeth in contact with the ground. Doing this may cause excessive force to be imposed on the rear of the machine, shortening the machine life.

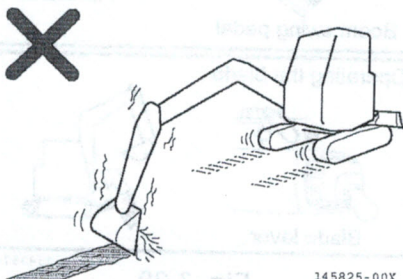

Fig. 3-31

■ Take care not to operate the hydraulic cylinder to the stroke end

Operating the hydraulic cylinder to the stroke end may impose an undue force on the stopper in the hydraulic cylinder, shortening the implement life. Operate with a small safety margin.

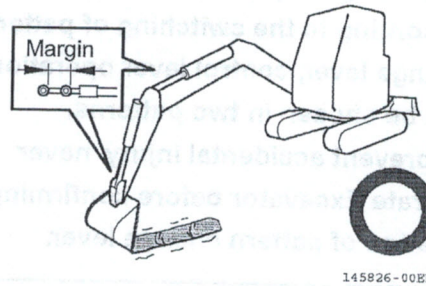

Fig. 3-32

■ Do not operate the implement by the using the dropping force of the bucket

Do not excavate the ground by using the dropping force of the bucket as a pickaxe or pile driver. Doing this may cause excessive force to be imposed on the rear of the machine, shortening the machine life and possibly causing a serious accident.

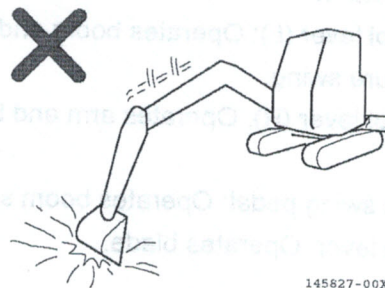

Fig. 3-33

■ **Do not operate the implement by using the dropping force of the machine**

Do not excavate the ground by using the dropping force of the machine.

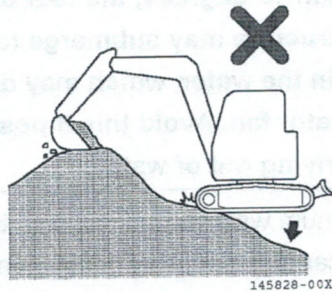

Fig. 3-34

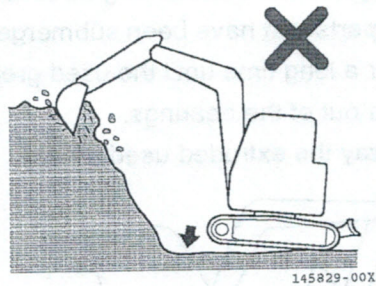

Fig. 3-35

■ **Excavating a hard rock**

It is recommended that a hard rock first be broken into small pieces by other means. Doing so will prevent damage to the machine and will increase economic efficiency.

■ **Do not bump the blade against a large rock or boulder**

Never bump the blade against a large rock or boulder. Doing so may cause the blade or the hydraulic cylinder to be damaged.

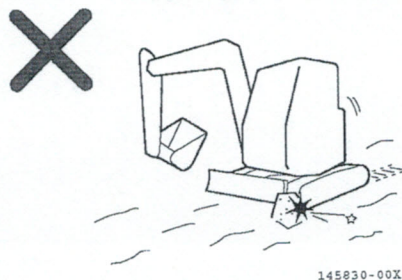

Fig. 3-36

■ **Be careful when retracting the implement**

When retracting the implement for travel or transport, be careful that the bucket and the blade never bump against each other.

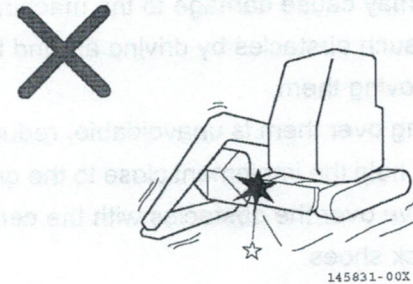

Fig. 3-37

■ **Support the blade on both sides**

When you use the blade as an outrigger, support the blade on both sides.

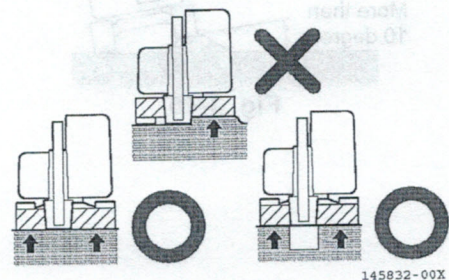

Fig. 3-38

■ **Be careful not to bump the blade when excavating**

When excavating the ground with the blade in front, never let the blade bump against the boom cylinder.

Place the blade in the rear, when it is not being used.

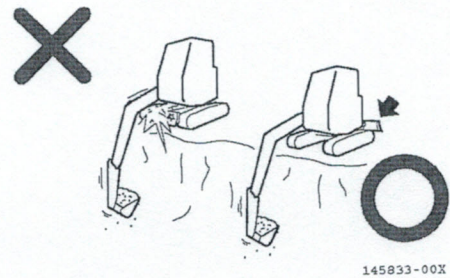

Fig. 3-39

Precautions for working

■ Precautions for traveling

Driving over a stone or a stump subjects the machine (especially undercarriage) to a shock, which may cause damage to the machine. Avoid such obstacles by driving around them, or removing them.

If driving over them is unavoidable, reduce speed, hold the implement close to the ground, and drive over the obstacles with the center of the track shoes.

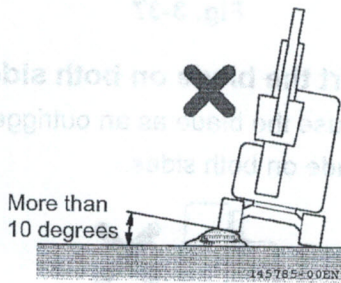

Fig. 3-40

■ Allowable water depth

IMPORTANT

When driving out of water, if the machine climbs a slope at an angle of more than 15 degrees, the rear of the upperstructure may submerge too deeply in the water, which may damage the radiator fan. Avoid this if possible when driving out of water.

The maximum water depth in which the machine can be used is up to the center of the carrier roller.

Apply a generous amount of grease to the moving parts that have been submerged in the water for a long time until the used grease is extruded out of the bearings.

Wipe away the extruded used grease.

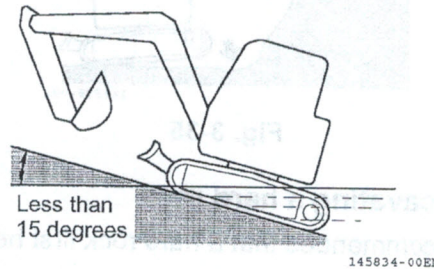

Fig. 3-41

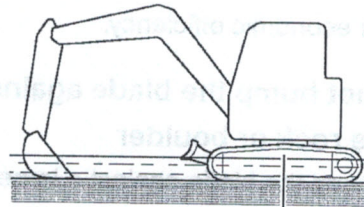

Fig. 3-42

Precautions for going up and down a slope

⚠ WARNING

- When traveling on a slope, place the implement in the direction of travel and raise the bucket 8 to 12 in. (20 to 30 cm) above the ground.
- When driving over obstacles such as foot paths, hold the implement close to the ground and drive the machine slowly.
- Never turn on or traverse a slope. Descend to flat ground to make a course change.
- If the machine is starting to slip or you feel that the machine is unstable, place the bucket on the ground and stop the machine at once.
- Recognize that the machine may roll over when swinging the upperstructure or operating the implement on a slope. Do not swing the upperstructure toward the downward side of the slope with a load in the bucket. If swinging is unavoidable, first lay earth on the slope to maintain the machine as horizontal as possible, then swing the upperstructure.
- Do not travel on a slope of 20 degrees or more, as the machine may upset.

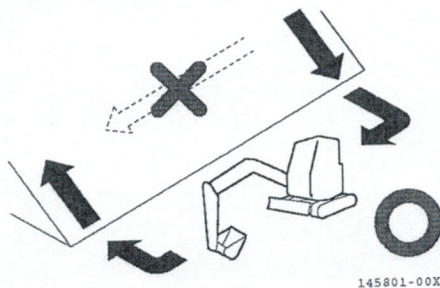

Fig. 3-43

145801-00X

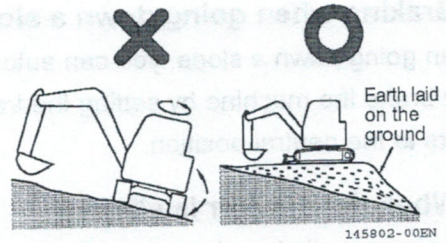

Fig. 3-44

145802-00EN

1. Go down slopes at low speed, using the travel levers and accelerator lever to control your speed. When going down a slope, drive the machine at low engine speed and position the implement as shown in the figure on Fig. 3-45.

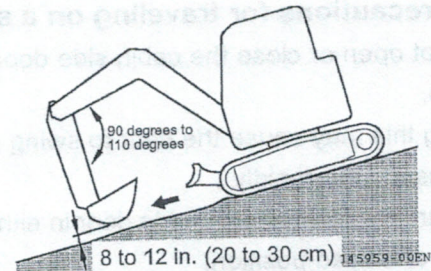

Fig. 3-45

145959-00EN

2. When climbing a slope, drive the machine with the implement positioned as shown in the figure on Fig. 3-46.

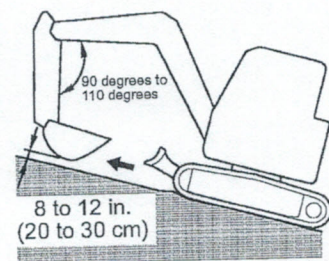

Fig. 3-46

145836-00EN

■ Braking when going down a slope

When going down a slope, you can automatically brake the machine by setting the travel levers to the neutral position.

■ When the crawler is slipping

If you cannot climb a slope by operating the travel levers because the crawler is slipping, retract the arm and use the pull-back power of the implement to help you climb the slope.

■ When the engine stops

If the engine stops while climbing a slope, set the travel levers to the neutral position, stop the machine, and restart the engine.

■ Precautions for traveling on a slope

Do not open or close the cabin side door on a slope.

Doing this may cause the door to swing open or closed very rapidly.

Be sure to lock the cabin side door in either the open or closed position.

Escaping from the mud

Carefully operate the machine not to allow it to get mired in mud. If the machine is mired in mud, the machine can escape as follows:

If only one track is mired in the mud

If only one track is mired in the mud, place the bucket on the muddy side, lift the track above the ground, lay a log or a wood block under the track shoe, and raise the bucket to escape.

IMPORTANT

When lifting the machine above the ground with the boom or the arm, push on the ground with the bottom of the bucket. (Do not push on the ground with the bucket teeth.)

In doing this, the angle between the boom and the arm should be 90 degrees to 110 degrees.

The same procedure described above should be utilized when the bucket is in the reverse position.

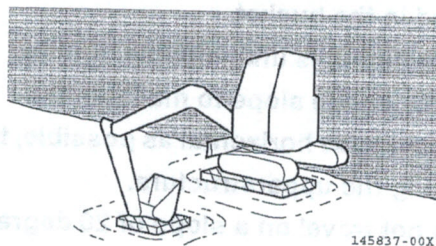

Fig. 3-47

If both tracks are mired in the mud

If both tracks are mired in the mud, lay a log or a wood block under the track shoes in the same manner as mentioned above, dig the bucket into the solid ground, retract the arm just as when excavating, and push the travel levers forward to escape from the mud.

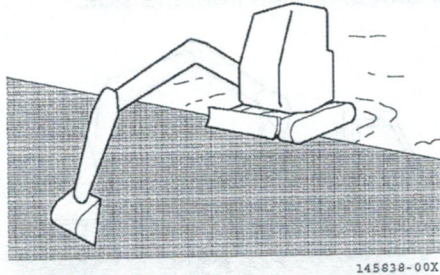

Fig. 3-48

Operations using the bucket

You can greatly widen the range of work described here by using optional attachments.

Backhoe operation

Backhoe operation is suitable for digging the ground below the machine. Suppose that the machine is operating as illustrated in the figure below: a maximum digging force of each cylinder can be obtained when the angle between the bucket cylinder and the bucket arm as well as between the arm cylinder and the arm is maintained at 90 degrees. When digging, make good use of this angle to increase the operating efficiency. To excavate the ground efficiently by manipulating the arm, the arm needs to be operated within a range of angles between 45 degrees forward and 30 degrees backwards, as illustrated in the figure below. Though the range differs according to the depth of the work, do not move the implement to the cylinder stroke end.

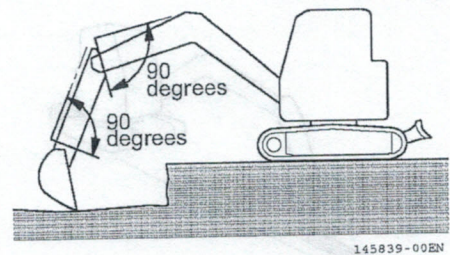

Fig. 3-49

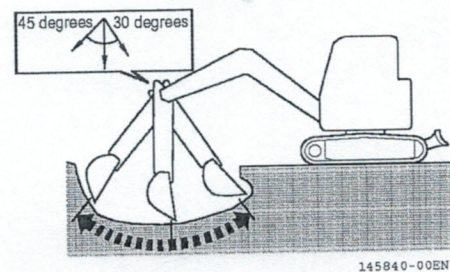
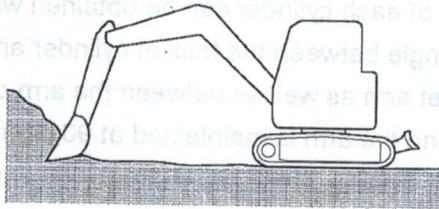

Fig. 3-50

Shoveling

Shoveling is suitable for excavating ground that is higher than the machine bottom. Install the bucket in the reverse position before operating.

For the procedure for installing the bucket in the reverse position, Refer to Section "Reversing the bucket without the quick coupler" on page 142.



145841-00X

Fig. 3-51

Ditching

To increase work efficiency, install a suitable bucket for ditching and position the tracks in parallel with the ditch to be made.

To make a wide ditch, first dig the two sides, and then dig the center.

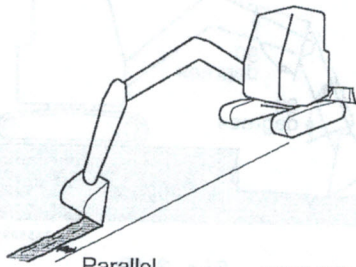

Parallel

145842-00EN

Fig. 3-52

Loading

To increase work efficiency, locate the dump truck at a position where the swing angle of the machine will be minimized and the operator can clearly view the dump truck.

Load earth from the rear of the dump truck, because it can be loaded more easily and in larger amounts than from the side.

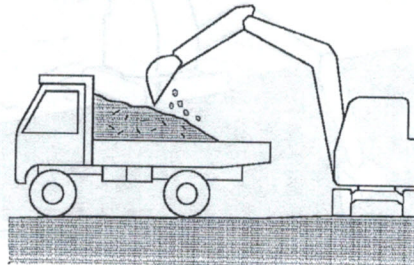

145843-00X

Fig. 3-53

Parking the machine

⚠ CAUTION

Do not stop the machine suddenly, but try to stop with a safety margin.

⚠ WARNING

- Park on solid, level ground.
- Do not park on a slope. If it is unavoidable to park on a slope, place solid blocks of wood behind the crawlers, place the blade on the ground, and dig the bucket into the ground.
- Do not touch the control levers and pedals accidentally. Otherwise, the implement or the machine may move unexpectedly, causing a serious accident.
- When leaving the operator's seat, be sure to place the lock lever securely in the lock position and remove the starter switch key.

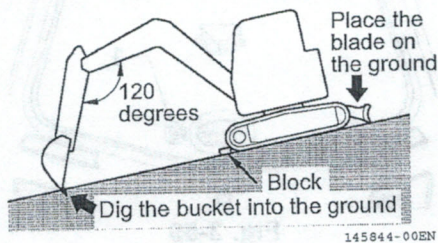

Fig. 3-54

1. Set the left and right travel levers (Fig. 3-55, 2) or pedals (Fig. 3-55, 3) to the neutral position to stop the machine.

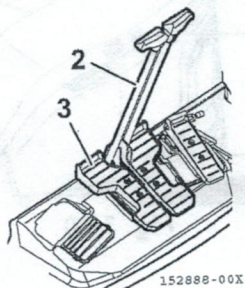

Fig. 3-55

2. Turn the engine control dial (Fig. 3-56, 2) to the Low idle direction.

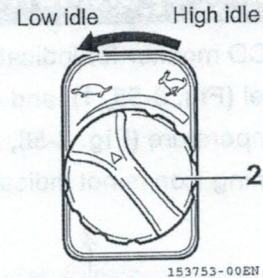

Fig. 3-56

3. Place the bucket on the ground with its bottom surface in contact with the ground.
4. Place the blade on the ground.

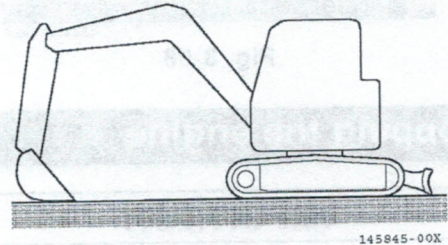

Fig. 3-57

5. Set the lock lever to the "LOCK" position.

Inspection requirements after completing operation

Check the LCD monitor for indication of remaining fuel (Fig. 3-58, 1), and engine cooling water temperature (Fig. 3-58, 2). Make sure the warning icon is not indicated.

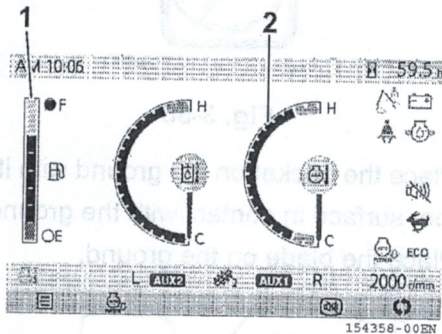

Fig. 3-58

Stopping the engine

IMPORTANT

Stopping the engine after rotation at high speed may shorten the engine life. Do not stop the engine suddenly except in case of emergency.

1. Operate the engine at low idle speed for approximately five minutes with no load. (The engine temperature gradually lowers.)
2. To stop the engine, turn the key to the "OFF" position.
3. Take the key out of the starter switch.

Note:

The swing motor brake will engage automatically when the engine stops.

Inspection requirements after stopping the engine

1. Check oil and water for leaks, and visually inspect the implement, the machine, and the undercarriage by walking around them. If there are any leaks of oil or water, or any observed abnormality, take corrective action.
2. Completely fill the fuel oil tank.
3. Confirm that the engine compartment is free of any foreign matter. Combustibles or dust in the engine compartment may cause a fire. Remove them, if any.
4. Remove mud adhering to the undercarriage of the machine.

Locking

Make sure that you lock the following parts:

1. Rear hood

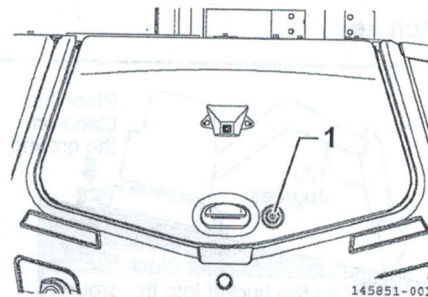

Fig. 3-59

2. Front cover (right)
3. Right hood

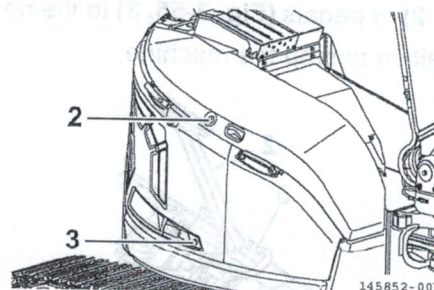

Fig. 3-60