



Operation & Maintenance Manual

*Original Instructions
Keep this manual with machine at all times.*

Models TL642C TL943C

S/N THG00150 & After
S/N THL00150 & After
S/N THH00150 & After
S/N SXH00150 & After

**31200747
SEBU9289-04**

*Revised
January 15, 2018*

CALIFORNIA PROPOSITION 65
BATTERY WARNING

**Battery posts,
terminals and related
accessories contain
lead and lead compounds,
chemical known to the
State of California
to cause cancer and
reproductive harm.**

**WASH HANDS
AFTER HANDLING!**

CALIFORNIA PROPOSITION 65
EXHAUST WARNING

**Diesel Engine exhaust and
some of its constituents
are known to the State of
California to cause cancer,
birth defects and other
reproductive harm.**

REVISION LOG

June 1, 2012 - A - Original Issue of Manual

October 31, 2014 - B - Revised pages 1-6, 1-7, 1-13, 2-4 thru 2-7, 3-2, 3-3, 3-22, 4-1, 4-13, 5-2, 5-11, 5-12, 5-16, 6-2, 7-3, 7-4, 8-1, 8-2, 9-1, 9-2, 9-3 & 9-4

January 30, 2015- C - Revised pages 9-1 & 9-3

April 20, 2016 - D - Revised cover and pages d & 3-13.

January 15, 2018 - E - Revised pages 5-2, 5-38 & 5-39.

Read This First

This manual is a very important tool! Keep it with the machine at all times.

The purpose of this manual is to provide owners, users, operators, lessors, and lessees with the precautions and operating procedures essential for the safe and proper machine operation for its intended purpose.

Due to continuous product improvements, JLG Industries, Inc. reserves the right to make specification changes without prior notification. Contact JLG Industries, Inc. for updated information.

Operator Qualifications

The operator of the machine must not operate the machine until this manual has been read, training is accomplished and operation of the machine has been completed under the supervision of an experienced and qualified operator. Operation within the U.S.A. requires training per OSHA 1910.178.

Operators of this equipment must possess a valid, applicable driver's license, be in good physical and mental condition, have normal reflexes and reaction time, good vision and depth perception and normal hearing. Operator must not be using medication which could impair abilities nor be under the influence of alcohol or any other intoxicant during the work shift.

In addition, the operator must read, understand and comply with instructions contained in the following material furnished with the telehandler:

- This Operation & Maintenance Manual
- Telehandler Safety Manual (ANSI only)
- All instructional decals and plates
- Any optional equipment instructions furnished

The operator must also read, understand and comply with all applicable Employer, Industry and Governmental rules, standards and regulations.

Modifications

Modifications to this machine may affect compliance with Industry Standards and/or Governmental Regulations. Any modification must be approved by JLG.

This product must comply with all safety related bulletins. Contact JLG Industries, Inc. or the local Caterpillar dealer representative for information regarding safety-related bulletins which may have been issued for this product.

JLG Industries, Inc. sends safety related bulletins to the owner of record of this machine. Contact JLG Industries, Inc. to ensure that the current owner records are updated and accurate.

JLG Industries, Inc. must be notified immediately in all instances where JLG products have been involved in an accident involving bodily injury or death of personnel or when damage has occurred to personal property or the JLG product.

FOR:

- Accident Reporting and Product Safety Publications
- Current Owner Updates
- Questions Regarding Product Applications and Safety
- Standards and Regulations Compliance Information
- Questions Regarding Product Modifications

CONTACT:

Product Safety and Reliability Department
JLG Industries, Inc.
13224 Fountainhead Plaza
Hagerstown, MD 21742
USA

In USA:

Toll Free: 1-877-JLG-SAFE (1-877-554-7233)

Outside USA:

Phone: +1-717-485-6591

E-mail:

ProductSafety@JLG.com

Read This First

Other Publications Available

Service Manual.....	31200794 (UENR6261)
Illustrated Parts Manual	
Before SN THG01209, Before SN THL00221,	
Before SN THH01519, Before SN SXH00253.....	31200723
SN THG01209 & After, SN THL00221 & After,.....	SEBP7160
SN THH01519 & After, SN SXH00253 & After.....	SEBP7161

Note: *The following standards may be referenced in this manual:*

ANSI is compliant to ANSI/ITSDF B56.6

AUS is compliant to AS 1418.19

CE is compliant to EN1459

Refer to the machine Serial Number Plate to identify the applicable compliance standard.

TABLE OF CONTENTS

Revision Log

Read This First

Operator Qualifications	b
Modifications	b
Other Publications Available	d

Table of Contents

Section 1 - General Safety Practices

1.1 Hazard Classification System	1-1
Safety Alert System and Safety Signal Words	1-1
1.2 General Precautions	1-1
1.3 Operation Safety	1-2
Electrical Hazards	1-2
Tip Over Hazard	1-3
Travel Hazard	1-6
Load Falling Hazard	1-7
Lifting Personnel	1-8
Driving Hazards On Slopes	1-9
Pinch Points and Crush Hazards	1-10
Fall Hazard	1-12
Chemical Hazards	1-13

Section 2 - Pre-Operation and Inspection

2.1 Pre-Operation Check and Inspection	2-1
2.2 Safety Decals	2-3
ANSI (THG00150 & After, THH00150 & After)	2-4
ISO (THL00150 & After, SXH00150 & After)	2-7
2.3 Walk-Around Inspection	2-10
2.4 Warm-Up and Operational Checks	2-12
Warm-Up Check	2-12
Operational Check	2-12
2.5 Operator Cab	2-13
2.6 Windows	2-14
Cab Door Window (if equipped)	2-14

Section 3 - Controls and Indicators

3.1 General	3-1
3.2 Controls	3-2
Dash Controls and Indicators	3-4
Ignition	3-6
Park Brake	3-7
Parking Procedure	3-7
Transmission Control Lever	3-8

Table of Contents

	Boom Joystick (TL642C)	3-10
	Boom Joystick (TL943C)	3-12
	Frame Level Joystick	3-14
	Auxiliary Hydraulic Joystick (TL642C)	3-15
	Outrigger Joysticks (if equipped)	3-16
	Right Hand Panel	3-17
	Accessory Control Lever (if equipped)	3-18
3.3	Steer Modes	3-19
	Steer Mode Change	3-19
3.4	Operator Seat	3-20
	Adjustments	3-20
	Seat Belt	3-21
3.5	Reverse Sensor System (if Equipped)	3-22
3.6	Boom Angle and Extension Indicators	3-23

Section 4 - Operation

4.1	Engine	4-1
	Starting the Engine	4-1
	Extreme Cold Weather Starting (if equipped)	4-2
	Battery Boosted Starting	4-3
	Normal Engine Operation	4-4
	Shut-Down Procedure	4-4
4.2	After-Treatment System (THG00150 & After; THH00150 & After)	4-6
	Automatic Regeneration	4-6
	Manual Regeneration	4-7
4.3	Operating with a Non-Suspended Load	4-8
	Lift Load Safely	4-8
	Picking Up a Load	4-8
	Transporting a Load	4-9
	Leveling Procedure	4-9
	Placing a Load	4-10
	Disengaging a Load	4-10
4.4	Operating with a Suspended Load	4-11
	Lift Load Safely	4-11
	Picking Up a Suspended Load	4-11
	Transporting a Suspended Load	4-12
	Leveling Procedure	4-12
	Placing a Suspended Load	4-13
	Disengaging a Suspended Load	4-13
4.5	Loading and Securing for Transport	4-14
	Tiedown	4-14
	Lifting	4-15

Section 5 - Attachments

5.1 Approved Attachments5-1

5.2 Unapproved Attachments5-1

5.3 JLG Supplied Attachments5-2

5.4 Telehandler/Attachment/Fork Capacity.....5-4

5.5 Use of the Load Chart.....5-5

 Capacity Indicator Locations5-5

 Sample Load Chart5-6

 Example5-8

5.6 Attachment Installation5-9

 Mechanical Quick Coupler5-10

 Hydraulic Quick Coupler5-11

5.7 Hydraulic Operated Attachment.....5-12

5.8 Adjusting/Moving Forks.....5-13

5.9 Attachment Operation5-14

 Carriage with Forks5-16

 Side Shift Carriage5-18

 Rotate/Side Tilt Carriage.....5-20

 Swing Carriage5-22

 Dual Fork Positioning Carriage5-24

 Fork Extension5-26

 Bucket5-28

 Multi-Purpose Bucket.....5-30

 Fork Mounted Hook5-32

 Coupler Mounted Hook5-34

 Truss Boom.....5-35

 Personnel Work Platform - Fork Mounted.....5-36

 Material Handling Arm5-38

 Boom Head-Mounted Winch5-40

Section 6 - Emergency Procedures

6.1 Towing a Disabled Product.....6-1

 Moving Short Distances6-1

 Moving Longer Distances6-1

6.2 Emergency Lowering of Boom.....6-2

6.3 Emergency Exit from Enclosed Cab6-2

 Fixed Window (if equipped)6-2

 Latch Window (if equipped)6-2

Table of Contents

Section 7 - Lubrication and Maintenance

7.1	Introduction.....	7-1
	Clothing and Safety Gear	7-1
7.2	General Maintenance Instructions.....	7-2
7.3	Service and Maintenance Schedule	7-3
	10, 1st 50 & 50 Hour Maintenance Schedule	7-3
	1st 250, 250 & 1st 500 Hour Maintenance Schedule	7-4
	500, 1000 & 1500 Hour Maintenance Schedule.....	7-5
	3000 Hour Maintenance Schedule	7-6
7.4	Lubrication Schedules	7-7
	50 Hour Lubrication Schedule	7-7
	250 Hour Lubrication Schedule	7-8
	1000 Hour Lubrication Schedule	7-9
7.5	Operator Maintenance Instructions	7-10
	Fuel System.....	7-10
	Air Intake System	7-12
	Engine Oil.....	7-14
	Hydraulic Oil	7-15
	Tires.....	7-16
	Transmission Oil.....	7-19
	Engine Cooling System	7-20
	Battery	7-21
	Windshield Washer System (if equipped).....	7-22

Section 8 - Additional Checks

8.1	General.....	8-1
8.2	Reverse Sensor System (if equipped).....	8-1

Section 9 - Specifications

9.1	Product Specifications.....	9-1
	Fluids	9-1
	Capacities.....	9-5
	Tires.....	9-6
	Performance	9-6
	Dimensions.....	9-8

Index

Inspection, Maintenance and Repair Log

SECTION 1 - GENERAL SAFETY PRACTICES

1.1 HAZARD CLASSIFICATION SYSTEM

Safety Alert System and Safety Signal Words



DANGER indicates an imminently hazardous situation which, if not avoided, will result in death or serious injury.



WARNING indicates a potentially hazardous situation which, if not avoided, could result in death or serious injury.



CAUTION indicates a potentiality hazardous situation which, if not avoided, may result in minor or moderate injury.

1.2 GENERAL PRECAUTIONS



Before operation, read and understand this manual. Failure to comply with the safety precautions listed in this manual could result in machine damage, property damage, personal injury or death.

Section 1 - General Safety Practices

1.3 OPERATION SAFETY

Electrical Hazards

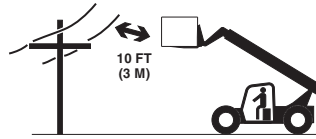
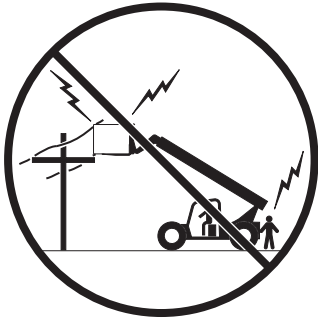

OW0040

- This machine is not insulated and does not provide protection from contact or being near electrical current.
- **NEVER** operate the telehandler in an area where overhead power lines, overhead or underground cables, or other power sources may exist without ensuring the appropriate power or utility company de-energizes the lines.
- Always check for power lines before raising the boom.
- Follow employer, local and governmental regulations for clearance from powerlines.

Tip Over Hazard

General

- For additional load requirements, refer to the appropriate load chart.

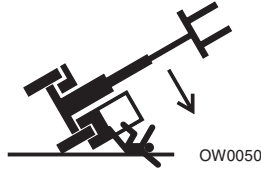

- Never use an attachment without the appropriate JLG approved load chart installed on the telehandler.
- Understand how to properly use the load charts located in cab.
- **DO NOT** exceed rated lift capacity.
- Be sure that the ground conditions are able to support the machine.

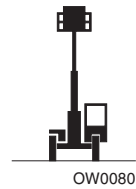
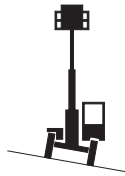
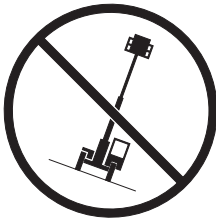

- **DO NOT** raise boom unless frame is level (0 degrees), unless otherwise noted on load chart.

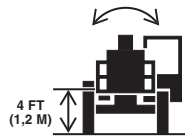
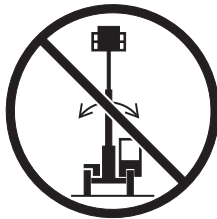

OW0100

- **DO NOT** level machine with boom/attachment above 4 ft (1,2 m). (AUS - **DO NOT** level machine with load more than 300 mm (11.8 in) above ground surface.)

Section 1 - General Safety Practices

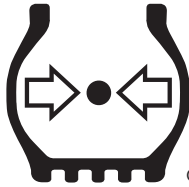

OH2291

- **MAINTAIN proper tire pressure** at all times. If proper tire pressures are not maintained, this machine could tip over.
- Refer to manufacturer's specifications for proper fill ratio and pressure requirements for tires equipped with ballast.



OH20911

- Always wear the seat belt.
- Keep head, arms, hands, legs and all other body parts inside operator's cab at all times.



OH2221

If the telehandler starts to tip over:

- **DO NOT JUMP**
- **BRACE YOURSELF** and **STAY WITH THE MACHINE**
- **KEEP YOUR SEAT BELT FASTENED**
- **HOLD ON FIRMLY**
- **LEAN AWAY FROM THE POINT OF IMPACT**

Non-Suspended Load



OW0060

- **DO NOT** drive with boom raised.

Suspended Load

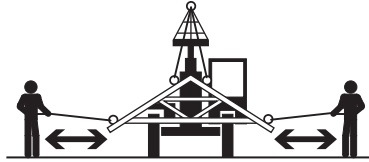
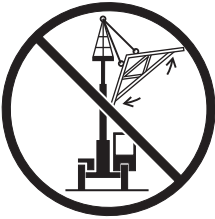

OW0150

- Tether suspended loads to restrict movement.
- Weight of all rigging (slings, etc.) must be included as part of load.
- Beware of wind. Wind can cause a suspended load to swing and cause dangerous side loads - even with tag lines.
- **DO NOT** attempt to use telehandler frame-leveling to compensate for load swing.
- Keep heavy part of load closest to attachment.
- Never drag the load; lift vertically.

When driving with a suspended load:

- Start, travel, turn and stop slowly to prevent load from swinging.
- **DO NOT** extend boom.
- **DO NOT** raise the load more than 11.8 in (300 mm) above ground surface or the boom more than 45°.
- **DO NOT** exceed walking speed.

Section 1 - General Safety Practices

Travel Hazard

2-Wheel Front Steer

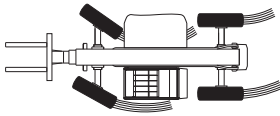

OAL2030

4-Wheel Circle Steer

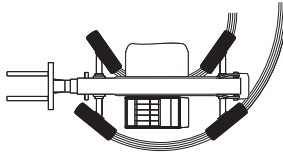

4-Wheel Crab Steer

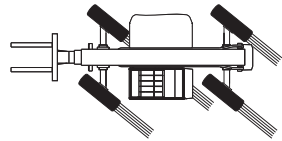

- Steering characteristics differ between steer modes. Identify the steer mode settings of the telehandler being operated.
- **DO NOT** change steer modes while traveling. Steer modes must be changed while telehandler is stationary.
- Visually verify proper wheel alignment after each steer mode change.
- Ensure that adequate clearance is provided for both rear tail swing and front fork swing.
- Look out for and avoid other personnel, machinery and vehicles in the area. Use a spotter if you DO NOT have a clear view.
- Before moving be sure of a clear path and sound horn.
- When driving, retract boom and keep boom/attachment as low as possible while maintaining visibility of mirrors and maximum visibility of path of travel.
- Always look in the direction of travel.
- Always check boom clearances carefully before driving underneath overhead obstructions. Position attachment/load to clear obstacles.
- When driving in high speed, use only front wheel steer (if steering modes are selectable).
- Telehandlers equipped with solid tires should not be used in applications requiring excessive roading or driving extended distances. In the event an application requires excessive roading or driving expanded distances, it is recommended to use telehandlers not equipped with solid tires.

Load Falling Hazard



OW0130

- Never suspend load from forks or other parts of carriage weldment. Use only approved lift points.
- **DO NOT** burn or drill holes in fork(s).
- Forks must be centered under load and spaced apart as far as possible.

Section 1 - General Safety Practices

Lifting Personnel



OW0170

- When lifting personnel, **USE ONLY** an approved personnel work platform, with proper load chart displayed in the cab.



OW0190

- **DO NOT** drive machine from cab when personnel are in platform.

Driving Hazards On Slopes

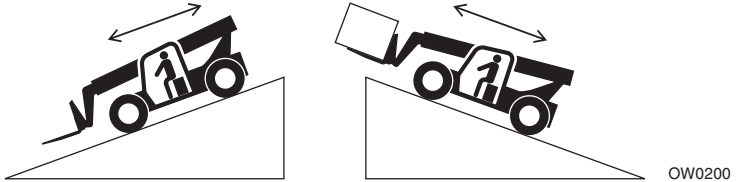

To maintain sufficient traction and braking capabilities, travel on slopes as follows:

- When unloaded, drive with forks pointed downhill.
- When loaded, drive with the forks pointed uphill.
- For additional travel requirements, refer to the appropriate load chart.
- To avoid overspeeding the engine and drivetrain when driving down slopes, downshift to a lower gear and use the service brake as necessary to maintain a slow speed. **DO NOT shift into neutral and coast downhill.**
- Avoid excessively steep slopes or unstable surfaces. To avoid tip over **DO NOT** drive across excessively steep slopes under *any* circumstances.
- Avoid turning on a slope. Never engage “inching” or shift to “Neutral” when going downhill.
- **DO NOT** park on a slope.

Section 1 - General Safety Practices

Pinch Points and Crush Hazards

Stay clear of pinch points and rotating parts on the telehandler.

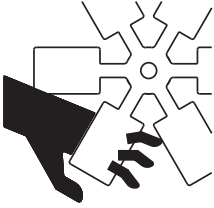

OW0210

- Stay clear of moving parts while engine is running.



OW0220

- Keep clear of steering tires and frame or other objects.



OW0230

- Keep clear from under boom.

Section 1 - General Safety Practices



OW0240

- Keep clear of boom holes.



OW0250

- Keep arms and hands clear of attachment tilt cylinder.



OW0260

- Keep hands and fingers clear of carriage and forks.

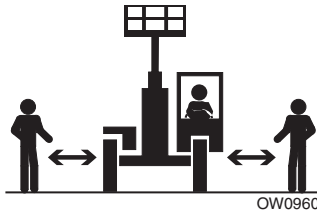

OW0960

- Keep others away while operating.

Section 1 - General Safety Practices

Fall Hazard



- Enter using the proper hand holds and steps provided. Always maintain 3-point contact when mounting or dismounting. Never grab control levers or steering wheel when mounting or dismounting the machine.
- **DO NOT** get off the machine until the shutdown procedure on page 4-4 has been performed.



- **DO NOT** carry riders. Riders could fall off machine causing death or serious injury.

Chemical Hazards

Exhaust Fumes

- **DO NOT** operate machine in an enclosed area without proper ventilation.
- **DO NOT** operate the machine in hazardous environments unless approved for that purpose by JLG and site owner. Sparks from the electrical system and the engine exhaust can cause an explosion.

Flammable Fuel



OW0300

- **DO NOT** fill the fuel tank or service the fuel system near an open flame, sparks or smoking materials. Engine fuel is flammable and can cause a fire and/or explosion.

Hydraulic Fluid



OW0950

- **DO NOT** attempt to repair or tighten any hydraulic hoses or fittings while the engine is running or when the hydraulic system is under pressure.
- Stop engine and relieve trapped pressure. Fluid in the hydraulic system is under enough pressure that it can penetrate the skin.
- **DO NOT** use your hand to check for leaks. Use a piece of cardboard or paper to search for leaks. Wear gloves to protect hands from spraying fluid.

This Page Intentionally Left Blank

SECTION 2 - PRE-OPERATION AND INSPECTION

2.1 PRE-OPERATION CHECK AND INSPECTION

Note: Complete all required maintenance before operating unit.



WARNING

FALL HAZARD. Use extreme caution when checking items beyond your normal reach. Use an approved ladder.

The pre-operation check and inspection, performed at beginning of each work shift or at each change of operator, should include the following:

1. **Cleanliness** - Check all surfaces for leakage (oil, fuel or battery fluid) or foreign objects. Report any leakage to the proper maintenance personnel.
2. **Structure** - Inspect the machine structure for dents, damage, weld or parent metal cracks or other discrepancies.

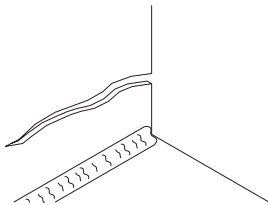

PARENT METAL CRACK

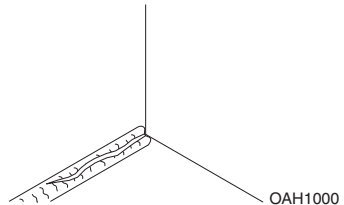

WELD CRACK

OAH1000

3. **Safety Decals** - Ensure all safety decals are legible and in place. Clean or replace as required. See page 2-3 for details.
4. **Operation and Safety Manuals** - Operation & Maintenance Manual and AEM Safety Manual (ANSI only) are located in cab manual holder.
5. **Walk-Around Inspection** - See page 2-10 for details.
6. **Fluid Levels** - Check fluids, including fuel, hydraulic oil, engine oil, transmission fluid and coolant. When adding fluids, refer to Section 7 - Lubrication and Maintenance and Section 9 - Specifications to determine proper type and intervals. Before removing filler caps or fill plugs, wipe all dirt and grease away from the ports. If dirt enters these ports, it can severely reduce component life.
7. **Attachments/Accessories** - Ensure correct load charts are installed on the telehandler. If provided, reference the Operation & Maintenance Manual of each attachment or accessory installed for specific inspection, operation and maintenance instructions.

Section 2 - Pre-Operation and Inspection

8. **Operational Check** - Once the walk-around inspection is complete, perform a warm-up and operational check (see page 2-12) of all systems in an area free of overhead and ground level obstructions. See Section 3 - Controls and Indicators for more specific operating instructions.



WARNING

If telehandler does not operate properly, immediately bring machine to a stop, lower boom and attachment to ground and stop the engine. Determine cause and correct before continued use.

2.2 SAFETY DECALS

Ensure all **DANGER, WARNING, CAUTION** and instructional decals and proper capacity charts are legible and in place. Clean and replace as required.

Note: *Part numbers referenced are for inspection and identification purposes only. Refer to the Parts Manual when ordering replacement parts.*

Section 2 - Pre-Operation and Inspection

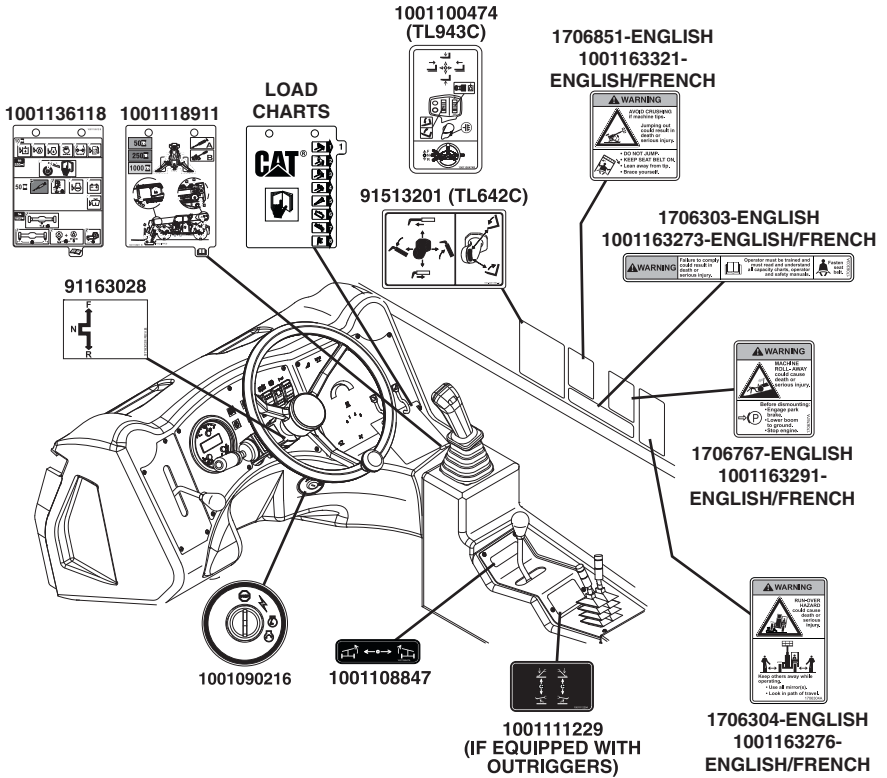

1706301-ENGLISH
1001163222-ENGLISH/FRENCH

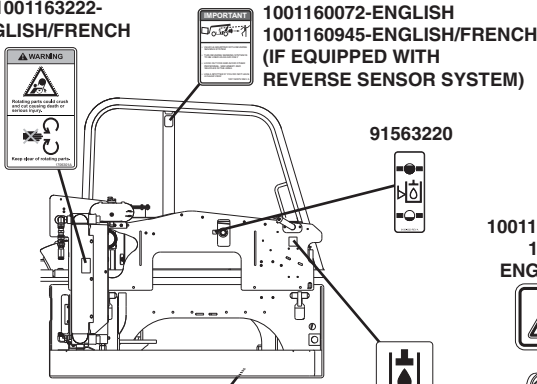

1706296-ENGLISH
1001163174-ENGLISH/FRENCH
VIEW OF ENGINE COMPARTMENT (COMPONENTS REMOVED FOR CLARITY)

1001139578-ENGLISH
1001163323-ENGLISH/FRENCH

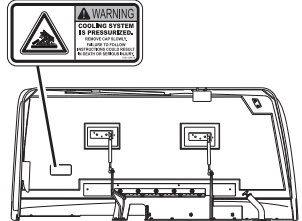

UNDERSIDE VIEW OF ENGINE COVER

OAL3442

Section 2 - Pre-Operation and Inspection

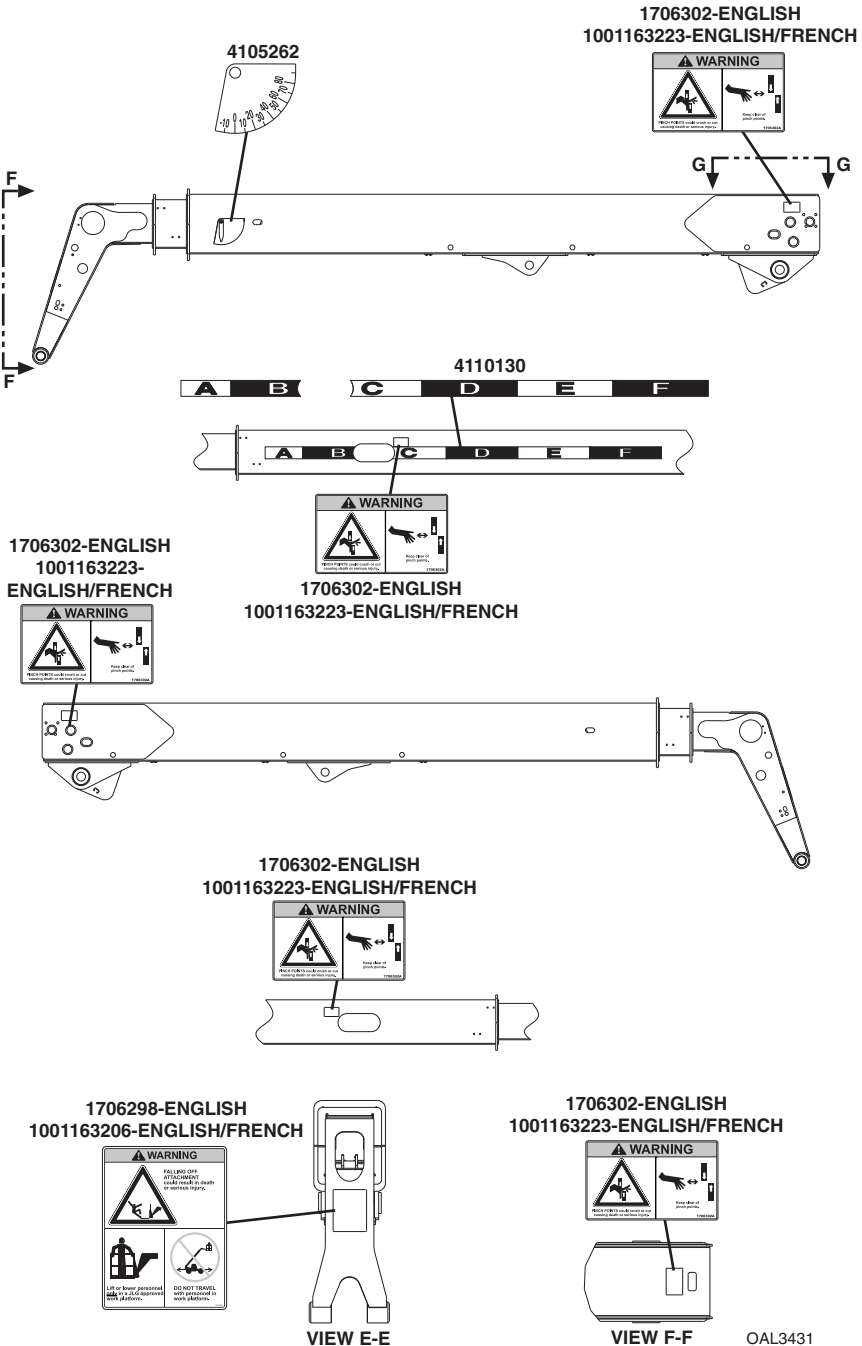

Section 2 - Pre-Operation and Inspection

ISO (THL00150 & After, SXH00150 & After)

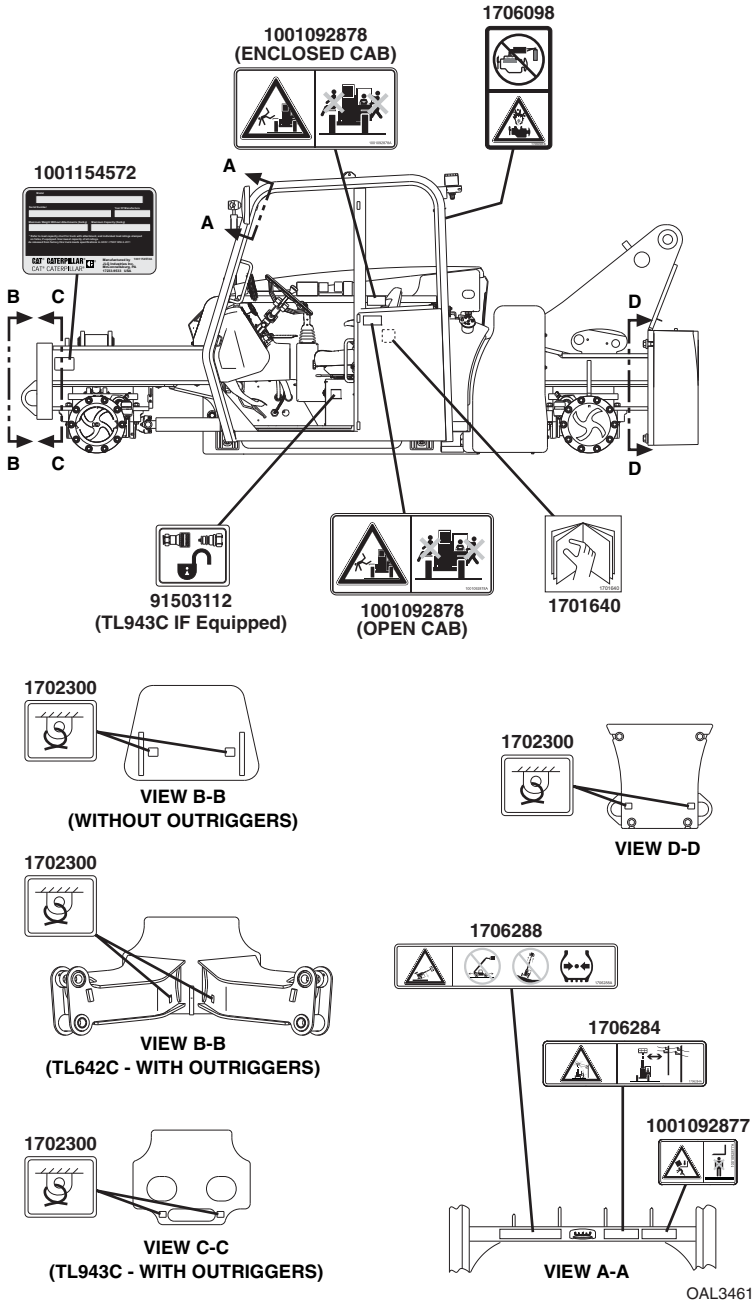

Section 2 - Pre-Operation and Inspection

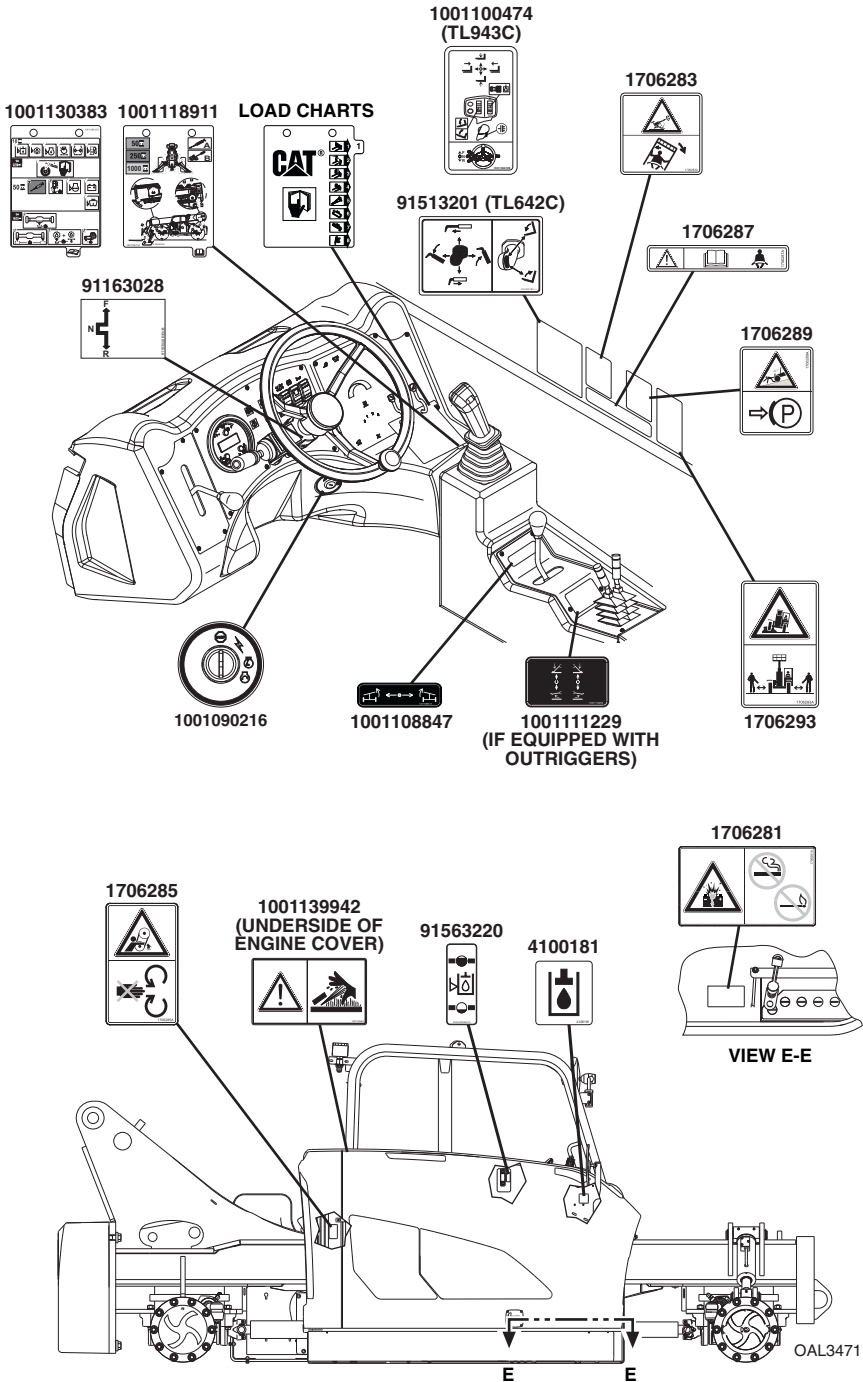

Section 2 - Pre-Operation and Inspection

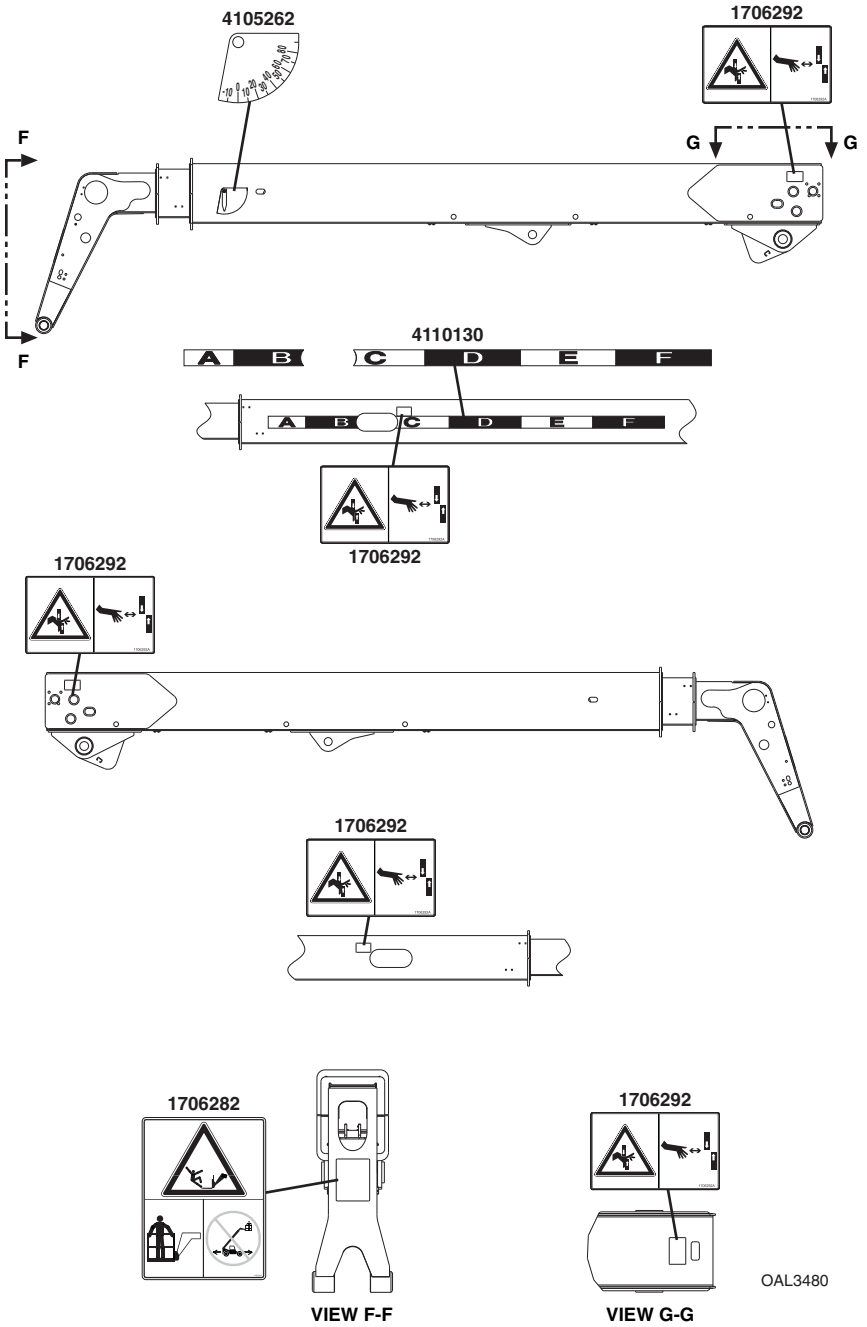

OAL3480

Section 2 - Pre-Operation and Inspection

2.3 WALK-AROUND INSPECTION

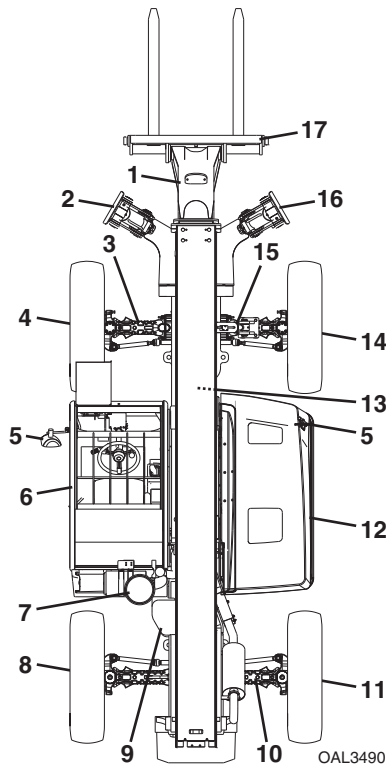

Begin your walk-around inspection at item 1, as noted below. Continue to your right (counterclockwise when viewed from top) checking each item in sequence.

INSPECTION NOTE: On all components, make sure there are no loose or missing parts, that they are securely fastened and no visible leaks or excessive wear exists in addition to any other criteria mentioned. Inspect all structural members including attachment for cracks, excessive corrosion and other damage.

1. Boom Sections and Lift, Tilt, Extend/Retract, Compensating (Slave) Cylinders -
 - Check front, top, side and rear wear pads for presence of grease.
 - Pivot pins secure; hydraulic hoses undamaged, not leaking.
2. Left Outrigger (if equipped) - Pins secure; hydraulic hoses and cylinder undamaged, not leaking.
3. Front Axle - Steer cylinders undamaged, not leaking; pivot pins secure; hydraulic hoses undamaged, not leaking.
4. Wheel/Tire Assembly - Properly inflated and secured; no loose or missing lug nuts. Inspect for worn tread, cuts, tears or other discrepancies.

Section 2 - Pre-Operation and Inspection

5. Mirrors - Clean and undamaged.
6. Cab and Electrical -
 - General appearance; no visible damage.
 - Frame level indicator and window glass undamaged and clean.
 - Gauges, switches, joysticks, foot controls and horn operational.
 - Emergency escape hammer in place (enclosed cab only).
 - Check seat belt for damage, replace belt if frayed or cut webbing, damaged buckles or loose mounting hardware.
7. Air Cleaner - Air cleaner element condition indicator, check for clogged condition. Replace element as required.
8. Wheel/Tire Assembly - Properly inflated and secured; no loose or missing lug nuts. Inspect for worn tread, cuts, tears or other discrepancies.
9. Main Control Valve - See inspection note.
10. Rear Axle - Steer cylinders undamaged, not leaking; pivot pins secure; hydraulic hoses undamaged, not leaking.
11. Wheel/Tire Assembly - Properly inflated and secured; no loose or missing lug nuts. Inspect for worn tread, cuts, tears or other discrepancies.
12. Engine Compartment -
 - Drive belts, check condition and replace as required.
 - Engine mounts - See inspection note.
 - Battery cables tight, no visible damage or corrosion.
 - Engine cover properly secured.
13. Outrigger Control Valve (if equipped) - See inspection note.
14. Wheel/Tire Assembly - Properly inflated and secured; no loose or missing lug nuts. Inspect for worn tread, cuts, tears or other discrepancies.
15. Frame Level Cylinder - Pins secure; hydraulic hoses undamaged, not leaking.
16. Right Outrigger (if equipped) - Pins secure; hydraulic hoses and cylinder undamaged, not leaking.
17. Attachment - Properly installed, see “*Attachment Installation*” on page 5-9.

Section 2 - Pre-Operation and Inspection

2.4 WARM-UP AND OPERATIONAL CHECKS

Warm-Up Check

During warm-up period, check:

1. Heater, defroster and windshield wiper (if equipped).
2. Check all lighting systems (if equipped) for proper operation.
3. Voltmeter should show 13.5 to 14 volts.
4. Adjust mirror(s) for maximum visibility.



WARNING

CUT/CRUSH/BURN HAZARD. Keep engine cover closed while engine is running except when checking transmission oil level.

Operational Check

When engine warms, perform an operational check:

1. Service brake and parking brake operation.
2. Forward and reverse travel.
3. Each gear.
4. Steering in both directions with engine at low idle (steering lock to lock will not be reached). Check in each steering mode.
5. Horn and back-up alarm. Must be audible from inside operator cab with engine running.
6. All boom and attachment functions - operate smoothly and correctly.
7. Perform any additional checks described in Section 8.

2.5 OPERATOR CAB

The telehandler is equipped with an open or enclosed ROPS/FOPS cab.



WARNING

Never operate telehandler unless the overhead guard, cab structure and right side glass or screen are in good condition. Any modification to this machine must be approved by JLG to assure compliance with ROPS/FOPS certification for this cab/machine configuration. If the overhead guard or cab structure is damaged, the **CAB CANNOT BE REPAIRED**. It must be **REPLACED**.

Section 2 - Pre-Operation and Inspection

2.6 WINDOWS

Keep all windows and mirrors clean and unobstructed.

Cab Door Window (if equipped)

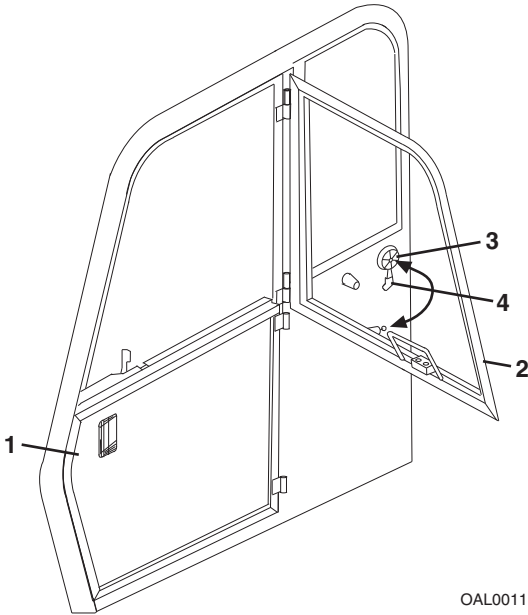

- Cab door (1) must be closed during operation.
- During operation the cab door window (2) must either be latched open or closed.
- Open the cab door window and secure it in the latch (3).
- Press release button inside the cab or pull on lever (4) outside the cab to unlatch the window.

SECTION 3 - CONTROLS AND INDICATORS

3.1 GENERAL

This section provides the necessary information needed to understand control functions.

Note: *The manufacturer has no direct control over machine application and operation. The user and operator are responsible for conforming with good safety practices.*

Section 3 - Controls and Indicators

3.2 CONTROLS

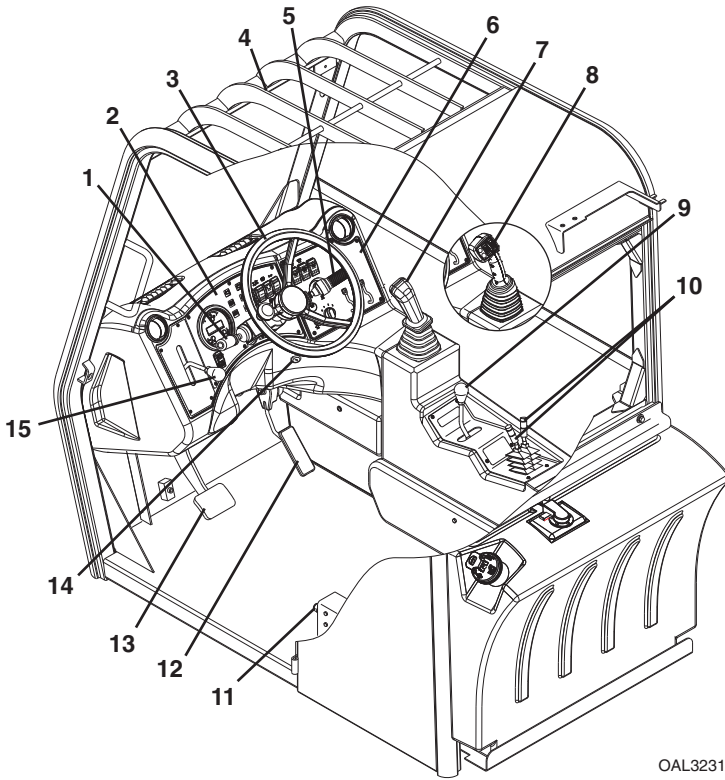

OAL3231

Section 3 - Controls and Indicators

1. Transmission Control Lever: See page 3-8.
2. Instrument Panel: See page 3-4.
3. Steering Wheel: Turning the steering wheel to the left or right steers the machine in the corresponding direction. Three steering modes are available. See “*Steer Modes*” on page 3-19.
4. Frame Level Indicator: Enables the operator to determine the left to right level condition of the telehandler.
5. Accessory Control Lever (if equipped): See page 3-18.
6. Right Hand Panel: See page 3-17.
7. Boom Joystick (TL642C): See page 3-10.
8. Boom Joystick (TL943C): See page 3-12.
9. Frame Level Joystick: See page 3-14.
10. Outrigger Joysticks (if equipped): See page 3-16.
11. Decompression Valve: Depress button to relieve pressure in auxiliary hydraulic circuit. See “*Hydraulic Operated Attachment*” on page 5-12.
12. Accelerator Pedal: Pressing down the pedal increases engine and hydraulic speed.
13. Service Brake Pedal: The further the pedal is depressed, the slower the travel speed.
14. Ignition Switch: Key activated. See page 3-6.
15. Auxiliary Hydraulic Joystick (TL642C): See page 3-15.

Section 3 - Controls and Indicators

Dash Controls and Indicators

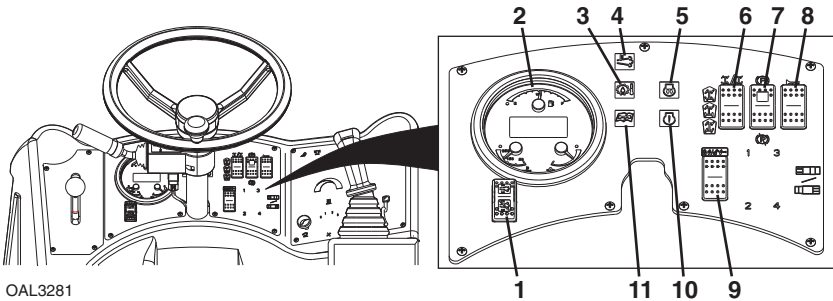

OAL3281

1. **Regeneration Switch** (THG00150 & After; THH00150 & After): Momentary switch used to inhibit regeneration or perform a manual regeneration. See page 4-6 for details.
2. **3-in-1 Gauge and Display:**
 - a. Engine Coolant Temperature Gauge
 - b. Engine Oil Pressure Gauge
 - c. Fuel Gauge
 - d. Display - Displays engine operating hours, battery voltage and engine rpm. Engine fault codes displayed when detected. See Service Manual for details.
3. **Transmission Temperature Indicator:** Illuminates red when transmission temperature is too high. Immediately bring machine to a stop, retract and lower boom and stop the engine. Determine cause and correct before continued use.
4. **High Exhaust System Temperature (HEST) Indicator** (THG00150 & After; THH00150 & After): Illuminates yellow during active regeneration. See page 4-6 for details.



WARNING

HIGH EXHAUST TEMPERATURE. Keep flammables and people away from hot exhaust.

5. **Engine Pre-Heat Indicator:** Illuminates yellow with ignition key in the "RUN" position. Indicator goes out when start temperature is reached.
6. **Steer Select Switch:** Three positions: 4-wheel circle steer, 4-wheel crab steer and 2-wheel steer. See page 3-19 for details.
7. **Park Brake Switch:** See page 3-7 for details.
8. **Horn Button:** Depress button to sound horn.

Section 3 - Controls and Indicators

9. Quick Coupler Switch (if equipped): Use in conjunction with the auxiliary hydraulic joystick to hydraulically lock or unlock an attachment. See “*Hydraulic Quick Coupler*” on page 5-11.
10. Engine Warning Indicator: Illuminates red when the engine is in a critical state. Immediately bring machine to a stop, retract and lower boom and stop the engine. Determine cause and correct before continued use.
11. Check Engine Indicator: Illuminates orange when maintenance is required. Engine may derate. See Service Manual for details.

Section 3 - Controls and Indicators

Ignition

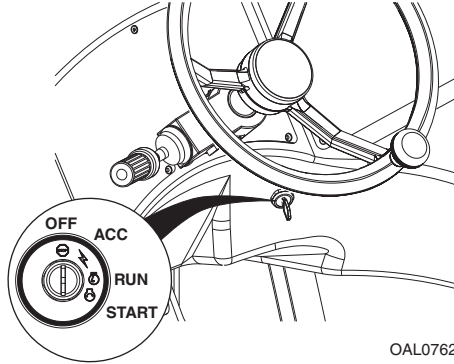

OAL0762

- In "ACC" or "RUN" position, voltage is available for all electrical functions.
- Full clockwise rotation to "START" engages starter motor.
- Counter-clockwise rotation to "OFF" stops engine and removes voltage from all electrical functions.

Park Brake



Park brake switch controls the application and release of the park brake. Indicator light on switch illuminates to indicate brake is applied.

- With the engine running and the park brake switch in "OFF" position (1), park brakes are disengaged.
- With switch in "ON" position (2), park brake is engaged and transmission will not engage forward or reverse.



WARNING

MACHINE ROLL-AWAY HAZARD. Always move park brake switch to "ON" position, lower boom to ground and stop engine before leaving cab.



WARNING

CRUSH HAZARD. Turning engine off applies the park brake. Applying park brake or turning engine off while traveling will cause unit to stop abruptly and could cause load loss. Either may be used in an emergency situation.

Parking Procedure

1. Using service brake, stop telehandler in an appropriate parking area.
2. Follow "Shut-Down Procedure" on page 4-4.

Section 3 - Controls and Indicators

Transmission Control Lever

Direction of Travel Selection

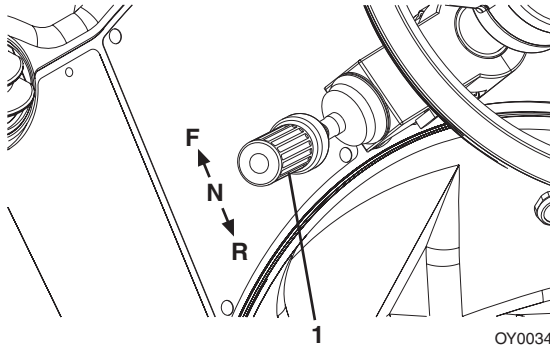

Transmission control lever (1) engages forward or reverse travel.

- Lift and push lever forward for forward travel; lift and pull lever rearward for reverse travel. Move lever to centered position for neutral.
- Forward or reverse travel can be selected while in any gear.
- When traveling in reverse, the back-up alarm will automatically sound.
- Drive in reverse and turn only at slow rates of speed.
- Do not increase engine speed with the transmission in forward or reverse and the service brake depressed in an attempt to get quicker hydraulic performances. This could cause unexpected machine movement.



WARNING

TIP OVER/CRUSH HAZARD. Bring telehandler to a complete stop before shifting transmission control lever. A sudden change in direction of travel could reduce stability and/or cause load to shift or fall.

NOTICE

EQUIPMENT DAMAGE.

- Do not downshift more than one gear at a time.
 - Bring telehandler to a complete stop before shifting transmission control lever into neutral or changing direction of travel.
- Improper use may result in transmission damage.

Gear Selection

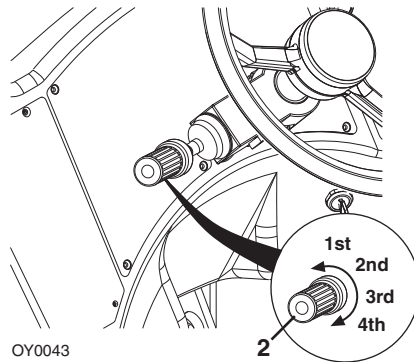

Gear selection is located on the twist grip handle (2) of transmission control lever.

- Twist hand grip to select gear.
- Select the appropriate gear for the task being performed. **Use a lower gear when transporting a load.** Use a higher gear only when driving unloaded for longer distances.
- Slow down prior to downshifting. **Do not downshift more than one gear at a time.**

Section 3 - Controls and Indicators

Boom Joystick (TL642C)

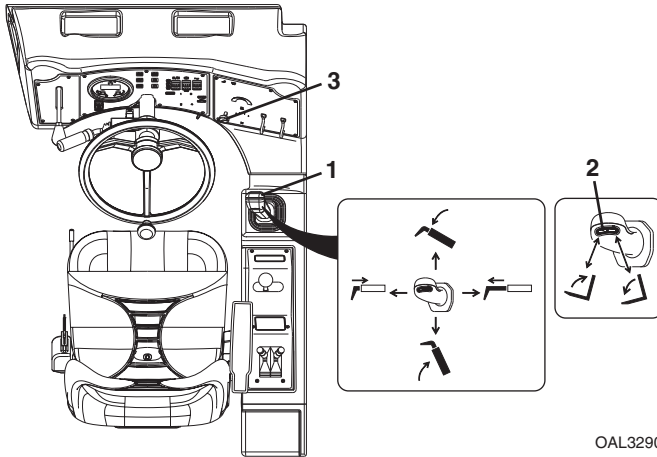

OAL3290

The boom joystick (1) controls the boom and attachment tilt functions.

Boom Functions

- Move the joystick back to lift boom; move joystick forward to lower boom; move joystick right to extend boom; move joystick left to retract boom.
- The speed of boom functions depends upon amount of joystick travel in corresponding direction. Increasing engine speed will also increase function speed.
- For two simultaneous boom functions, move the joystick between quadrants. For example; moving the joystick forward and to the left will lower and retract boom simultaneously.

Attachment Function

Tilt control is actuated by the switch (2).

- Depress the left side of the switch to tilt up; depress the right side of switch to tilt down.
- Use knob (3) to regulate the speed of the tilt. Rotate knob counter-clockwise to increase speed; rotate knob clockwise to decrease speed.



WARNING

TIP OVER/CRUSH HAZARD. Rapid, jerky operation of controls will cause rapid, jerky movement of the load. Such movements could cause the load to shift or fall or could cause the machine to tip over.

This Page Intentionally Left Blank

Section 3 - Controls and Indicators

Boom Joystick (TL943C)

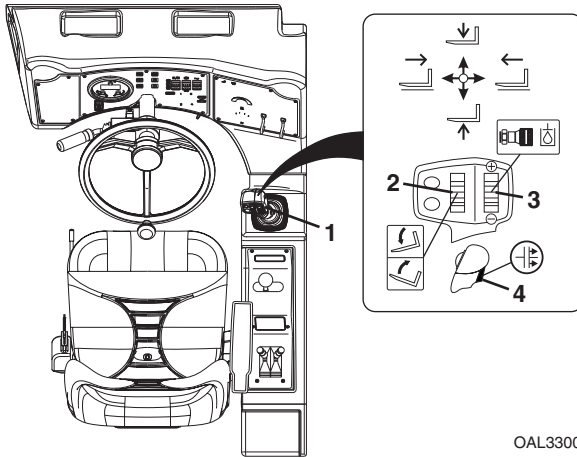

The boom joystick (1) controls the boom, attachment tilt, auxiliary hydraulic and clutch lock functions.

Boom Functions

- Move the joystick back to lift boom; move joystick forward to lower boom; move joystick right to extend boom; move joystick left to retract boom.
- The speed of boom functions depends upon the amount of joystick travel in corresponding direction. Increasing engine speed will also increase function speed.
- For two simultaneous boom functions, move the joystick between quadrants. For example; moving the joystick forward and to the left will lower and retract boom simultaneously.



WARNING

TIP OVER/CRUSH HAZARD. Rapid, jerky operation of controls will cause rapid, jerky movement of the load. Such movements could cause the load to shift or fall or could cause the machine to tip over.

Attachment Function

Attachment tilt is controlled by the roller switch (2).

- Push the roller switch up to tilt attachment down; push the roller switch down to tilt attachment up.

Auxiliary Hydraulic Functions

Auxiliary Hydraulics roller switch (3) controls function of attachments that require hydraulic supply for operation. See Section 5- Attachments for approved attachments and control instructions.

Clutch Lock Switch

Clutch Lock is controlled by the joystick trigger (4).

- Squeeze and release trigger once to deactivate system and have transmission disengage. Quickly squeeze and release trigger twice to activate system and keep transmission engaged.

Section 3 - Controls and Indicators

Frame Level Joystick

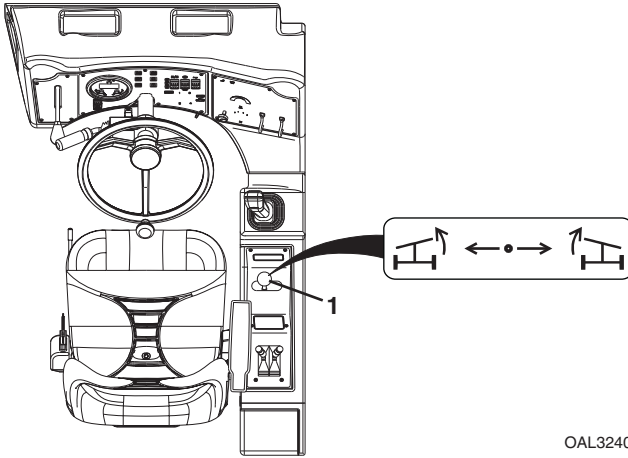

OAL3240

The frame level joystick (1) controls the left to right frame level.

- Move the joystick left to rotate frame left, move the joystick right to rotate frame right.
- A level indicator is located above the front cab window to permit operator to determine whether the telehandler frame is level.



WARNING

TIP OVER HAZARD. Always move boom as low as possible while allowing for best visibility of right hand mirror before leveling frame. Attempting to level machine with boom raised could cause it to tip over.

Auxiliary Hydraulic Joystick (TL642C)

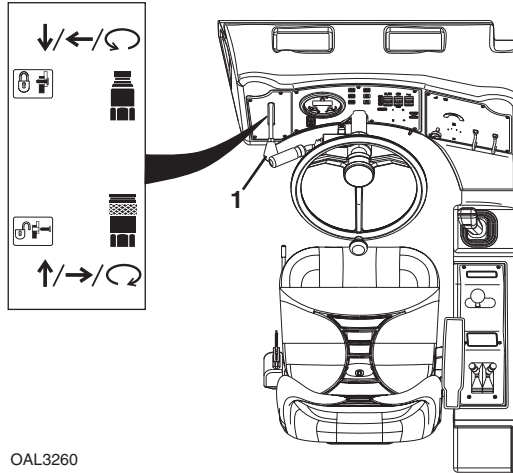

OAL3260

The auxiliary hydraulic joystick (1) controls function of attachments that require hydraulic supply for operation. See Section 5- Attachments for approved attachments and control instructions.

Section 3 - Controls and Indicators

Outrigger Joysticks (if equipped)

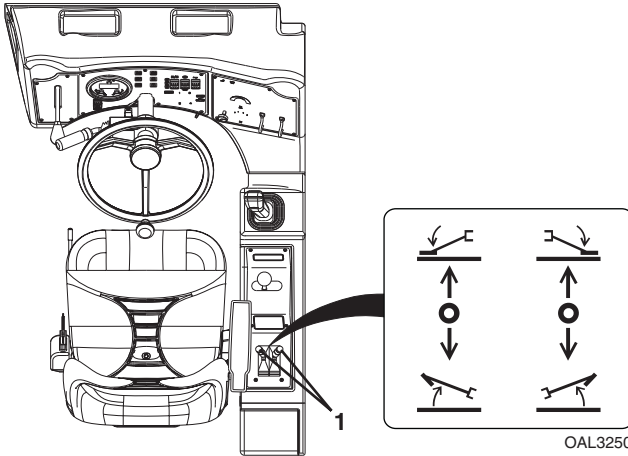

The rear joysticks (1) control the outriggers.

- Left joystick controls left outrigger and the right joystick controls right outrigger.
- Push joysticks forward to lower outriggers; push joysticks back to raise outriggers.
- Use outriggers to increase stability and/or load capacity and in leveling the telehandler. Study load charts to determine maximum load capacities, with and without outriggers.



WARNING

TIP OVER HAZARD. Outriggers increase stability and load capacity only if they are used properly. Using outriggers on soft surfaces could cause telehandler to tip over. Always ensure surface can support telehandler and load.

Right Hand Panel

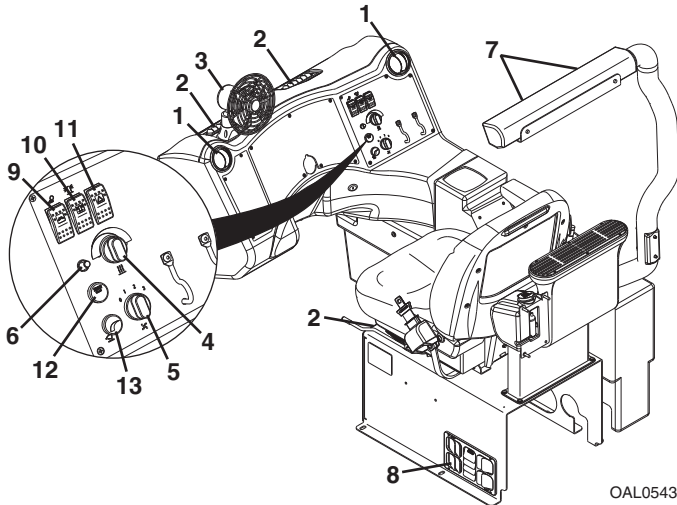

Heater and Air Conditioning Controls (if equipped)

1. Air Vent: Two individually adjustable round vents.
2. Air Louver: Three individually adjustable air louvers.
3. Defroster Fan: Two speed fan. Press fan switch down for slow speed; press switch up for fast speed. Return switch to middle position to turn off.
4. Temperature Control Switch: Adjustable rotary switch
5. Fan Speed: Four-position rotary switch.
6. Air Conditioning Switch: On/Off switch.
7. Air Louver: Two individually adjustable air louvers.
8. Recirculation Vent: Open louvers when operating heat. Close louvers when operating air conditioning.

Other Controls (if equipped)

9. Work Light Switch: On/Off switch.
10. Beacon Light Switch: On/Off switch.
11. Hazard Light Switch: On/Off switch.
12. Windshield Wiper and Washer Switch: Two speed rotary switch. Depress to activate washer. Return to first position to turn off wiper.
13. Attachment Tilt Speed Switch (TL642C): See page 3-10.

Section 3 - Controls and Indicators

Accessory Control Lever (if equipped)

The accessory control lever (1) operates the turn signals, parking lights and headlights.

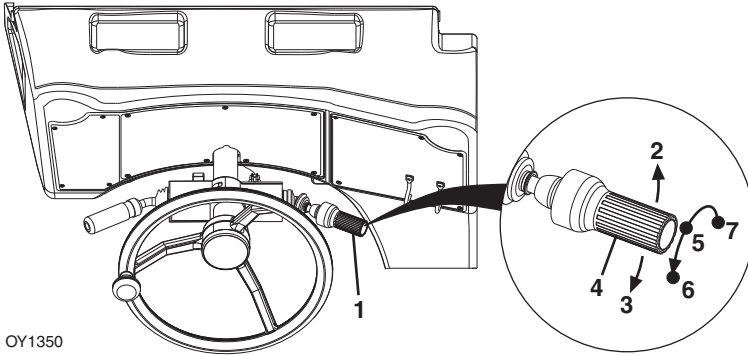

OY1350

Turn Signal

- Push the lever forward (2) to activate the left turn signal.
- Pull the lever back (3) to activate the right turn signal.
- The lever must be manually returned to the center position to deactivate either turn signal. The lever will not cancel automatically after a turn.

Parking Lights and Headlights

- Turn the twist grip (4) of the lever counterclockwise to the first position (5) to turn on the parking lights.
- Turn the twist grip to the second position (6) to turn on the headlights.
- Raise/lower the lever to switch between low beam and high beam.
- Turn the twist grip clockwise to the OFF position (7) to turn all lights off.

3.3 STEER MODES

Three steer modes are available for operator use.

2-Wheel Front Steer

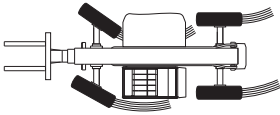

OAL2030

4-Wheel Circle Steer

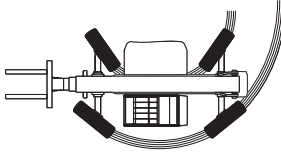

4-Wheel Crab Steer

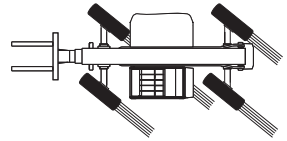

Note: 2-Wheel Front Steer mode is required for travel on public roads.

Steer Mode Change

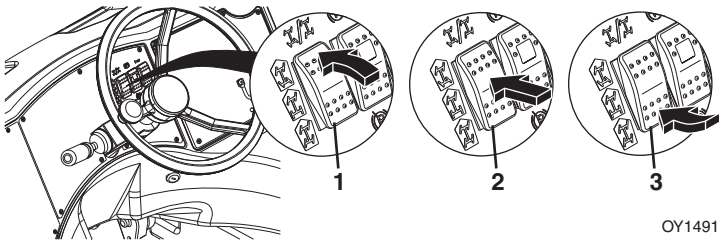

1. Bring machine to a stop using service brake while either circle steer mode (1) or crab steer mode (3) is selected.

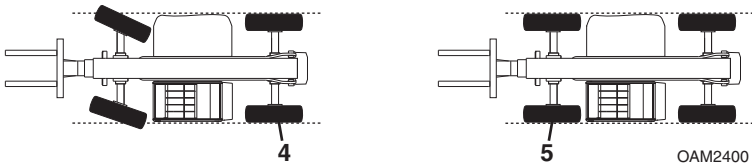

2. Turn the steering wheel until the left rear wheel (4) is aligned with the side of the machine.
3. Select front steer mode (2).
4. Turn the steering wheel until the left front wheel (5) is aligned with the side of the machine.
5. Wheels are now aligned. Select desired steer mode.

Section 3 - Controls and Indicators

3.4 OPERATOR SEAT

Adjustments

Prior to starting engine adjust seat for position and comfort.

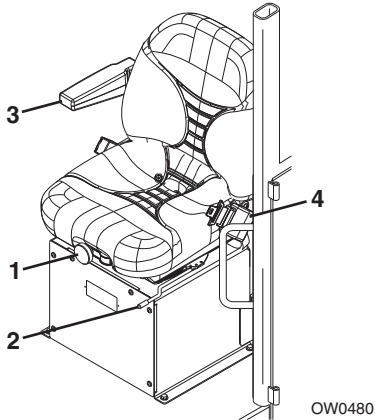

1. Suspension: Use knob to adjust suspension to the appropriate setting. Turn clockwise to increase stiffness. Turn counterclockwise to reduce stiffness.
2. Fore/Aft: Pull up on handle to move seat fore and aft.
3. Arm Rest: Arm rest can be moved up or down for comfort.
4. Seat Belt: Always fasten seat belt during operation. If required, a 3 in (76 mm) seat belt is available.

Seat Belt



Fasten seat belt as follows:

1. Grasp both free ends of the belt making certain that belt webbing is not twisted or entangled.
2. With back straight in the seat, couple the retractable end (male end) of the belt into the receptacle (buckle) end of the belt.
3. With belt buckle positioned as low on the body as possible, pull the retractable end of the belt away from the buckle until it is tight across the lap.
4. To release belt latch, depress red button on the buckle and pull free end from buckle.

Section 3 - Controls and Indicators

3.5 REVERSE SENSOR SYSTEM (IF EQUIPPED)

Reverse Sensor System provides audible indication of objects to rear of unit while in reverse gear.

- Alarm sounds signaling machine is placed in reverse gear.

Note: *Reverse Sensing System detects objects larger than 36 square inches (232.25 square centimeters) area and is functional when machine is moving in reverse direction.*

- No alarm when detection zone is clear of objects.
- Pulsing alarm sounds when an object is in range of Reverse Sensing System. Alarm increases in frequency as object becomes closer.
- If alarm sounds at a frequency of eight pulses per second (8 Hz) an object is detected within 5 feet (1.5 m). Stop reverse direction of machine by applying service brake. Perform “*Shut-Down Procedure*” on page 4-4. Check and clear area behind machine of objects before proceeding in a reverse direction.

3.6 BOOM ANGLE AND EXTENSION INDICATORS

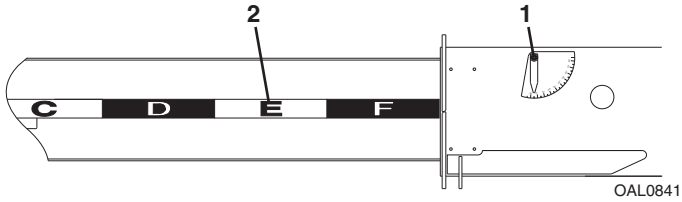

- The boom angle indicator (1) is located on the left side of the boom. Use this indicator to determine the boom angle when using the capacity chart (see “Use of the Load Chart” on page 5-5).
- The boom extension indicators (2) are located on the left side of the boom. Use these indicators to determine boom extension when using the capacity chart (see “Use of the Load Chart” on page 5-5).

This Page Intentionally Left Blank

SECTION 4 - OPERATION

4.1 ENGINE

Starting the Engine

This machine can be operated under normal conditions in temperatures of 0°F to 104°F (-20°C to 40°C). Consult the local Caterpillar dealer for operation outside this range or under abnormal conditions.

If equipped for extreme cold weather, -40°F to 0°F (-40°C to -20°C), see page 4-2 for starting procedure.

1. Make sure all controls are in “Neutral” and all electrical components (lights, heater, defroster, etc.) are turned off. Apply park brake.
2. Turn the ignition switch to “RUN” position and wait until engine pre-heat indicator light goes out.
3. Turn ignition switch to “START” to engage starting motor. Release key immediately when engine starts. If engine fails to start within 20 seconds, release key and allow starting motor to cool for two minutes before trying again.
4. After engine starts, observe oil pressure gauge. If gauge remains on zero for more than ten seconds, stop engine and determine cause before restarting engine.

Note: *If engine pre-heat indicator flashes after engine starts, accelerator pedal is deactivated until indicator goes out.*

5. Warm up engine at approximately 1/2 throttle.

Note: *Engine will not start unless transmission control lever is in “Neutral” and park brake switch is applied.*



WARNING

ENGINE EXPLOSION. Do not use ether for cold weather starting.



WARNING

UNEXPECTED MOVEMENT HAZARD. Always ensure that transmission control lever is in neutral and the service brake is applied before releasing park brake. Releasing park brake in either forward or reverse could cause the machine to move abruptly.

Section 4 - Operation

Extreme Cold Weather Starting (if equipped)

If equipped with extreme cold weather components, machine can be operated in temperatures of -40°F to 0°F (-40° C to -20° C).

1. Machine must be equipped with heating components and extreme cold weather fluids. See Section 9 - Specifications for fluid details.
2. Locate the two yellow extension cords stored behind seat in cab.
3. Connect the oil pan and hydraulic tank heaters to one extension cord and the battery and block heaters to the other extension cord. Connect each extension cord to separate A/C power supplies with a minimum rating of 15 Amps each.
4. Allow heating components to operate a minimum of 12 hours prior to machine operation.

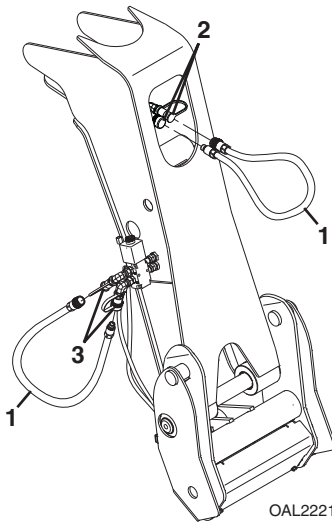

5. Locate recirculation hoses stored behind seat in cab.
6. Connect recirculation hose (1) to tilt circuit quick disconnects (2). Connect the other recirculation hose (1) to auxiliary hydraulic quick disconnects (3).
7. Follow start-up procedure on page 4-1 and allow engine to idle 20 minutes.
8. Operate tilt and auxiliary hydraulic functions continuously for five minutes to circulate the warm hydraulic fluid.
9. Operate all boom functions continuously for another five minutes.
10. Perform "Shut-Down Procedure" on page 4-4.
11. Disconnect recirculation hoses and A/C power supplies and place back in storage locations.
12. Machine is ready for operation.

Battery Boosted Starting



OW0530

If battery-boost starting (jump-start) is necessary, proceed as follows:

- Never allow vehicles to touch.
- Ensure boosting vehicle engine is running.
- Connect the positive (+) jumper cable to positive (+) post of discharged battery.
- Connect the opposite end of positive (+) jumper cable to positive (+) post of booster battery.
- Connect the negative (-) jumper cable to negative (-) post on booster battery.
- Connect opposite end of negative (-) jumper cable to ground point on machine away from discharged battery.
- Follow standard starting procedures.
- Remove cables in reverse order after machine has started.



WARNING

BATTERY EXPLOSION HAZARD. Never jump start or charge a frozen battery as it could explode. Keep sparks, flames and lighted smoking materials away from the battery. Lead acid batteries generate explosive gases when charging. Wear safety glasses.

Section 4 - Operation

Normal Engine Operation

- Observe instrument panel frequently to be sure all systems are functioning properly.
- **Be alert for unusual noises or vibration.** When an unusual condition is noticed, park machine in safe position and perform shut-down procedure. Report condition to your supervisor or local Caterpillar dealer.
- **Avoid prolonged idling.** If the engine is not being used, turn it off.
- (S/N THG00150 & After; S/N THH00150 & After) Prolonged operation in 9,800 ft to 13,100 ft (3000 m to 4000 m) altitudes requires the following restrictions.
 - Minimum fuel level should be no less than 1/4 tank.
 - Fuel filter maintenance increased to 250 hours.

Shut-Down Procedure

When parking the telehandler, park in a safe location on flat level ground and away from other equipment and/or traffic lanes.

1. Apply the park brake.
2. Shift the transmission to "Neutral."
3. Lower forks or attachment to the ground.
4. Operate engine at low idle for 3 to 5 minutes. **DO NOT over rev engine.**
5. Shut off engine and remove ignition key.
6. Exit telehandler properly.
7. Block wheels (if necessary).

This Page Intentionally Left Blank

Section 4 - Operation

4.2 AFTER-TREATMENT SYSTEM (THG00150 & AFTER; THH00150 & AFTER)

This machine is equipped with an exhaust After-Treatment System (ATS). The ATS includes a Diesel Particulate Filter (DPF), regeneration switch and indicators.

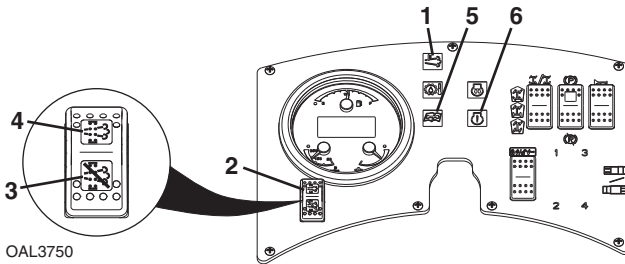

Automatic Regeneration

ATS is in automatic regeneration mode at start-up and will perform regenerations as required without any operator interaction.

- High Exhaust System Temperature (HEST) Indicator (1) illuminates during and shortly after active regeneration.



WARNING

HIGH EXHAUST TEMPERATURE. Keep flammables and people away from hot exhaust.

- If operating in a sensitive environment or to stop an active regeneration, depress and hold bottom of regeneration switch (2) until indicator (3) illuminates to inhibit regeneration.
- With inhibit mode active, regeneration indicator (4) will illuminate when regeneration is required.
- Move telehandler to an area free of flammables and people that could be exposed to hot exhaust. Deactivate inhibit function by depressing bottom of regeneration switch until indicator goes out. The machine is now in automatic regeneration mode and will perform a regeneration as needed.

Manual Regeneration

If inhibit function is continually utilized, the regeneration indicator (4) illuminates, check engine indicator (5) flashes and engine will derate. A manual regeneration is required at this point.

1. Move telehandler to an area free of flammables and people that could be exposed to hot exhaust.
2. Apply park brake, shift transmission to neutral and lower boom.
3. Deactivate inhibit function by depressing bottom of regeneration switch until indicator (3) goes out.
4. To activate ATS regeneration, depress top of regeneration switch (2) until engine rpm begins to increase. Engine will ramp up to approximately 2000 rpm.
5. Do not depress accelerator pedal or other controls during an active regeneration.

Note: *If a manual regeneration must be interrupted, the operator can do so by depressing the bottom of the regeneration switch, releasing the park brake, shifting the transmission into forward or reverse, depressing the accelerator pedal or by turning off the engine.*

6. HEST indicator (1) illuminates during and shortly after active regeneration.



WARNING

HIGH EXHAUST TEMPERATURE. Keep flammables and people away from hot exhaust.

7. Manual regeneration takes up to approximately 25 minutes to complete.
8. Manual regeneration is complete after engine returns to idle and HEST indicator goes out.

NOTICE

EQUIPMENT DAMAGE. If manual regeneration requirement is continually ignored, the regeneration (4), check engine (5) and engine warning (6) indicators will illuminate. Immediately bring machine to a stop, retract and lower boom and stop the engine. Regeneration is no longer available and machine must be serviced. Contact the local Caterpillar dealer for further information.

Section 4 - Operation

4.3 OPERATING WITH A NON-SUSPENDED LOAD

Lift Load Safely

- You must know the weight and load center of every load you lift. If you are not sure of the weight and load center, check with your supervisor or with the supplier of the material.



WARNING

TIP OVER HAZARD. Exceeding lift capacity of the telehandler could damage the equipment and/or cause tip over.

- Know the rated load capacities (see Section 5) of the telehandler to determine the operating range in which you can safely lift, transport and place a load.

Picking Up a Load

- Note the conditions of the terrain. Adjust travel speed and reduce amount of load if conditions warrant.
- Avoid lifting double-tiered loads.
- Make sure load is clear of any adjacent obstacles.
- Adjust spacing of forks so they engage the pallet or load at maximum width. See “*Adjusting/Moving Forks*” on page 5-13.
- Approach load slowly and squarely with fork tips straight and level. **NEVER** attempt to lift a load with just one fork.
- **NEVER** operate telehandler without a proper and legible load chart in the operator cab for the telehandler/attachment combination you are using.

Transporting a Load



After engaging the load and resting it against the backrest, tilt the load back to position it for travel. Travel in accordance with the requirements set forth in Section 1 - General Safety Practices and Section 5- Attachments.

Leveling Procedure

1. Position machine in best location to lift or place load.
2. Apply parking brake and move transmission control lever to NEUTRAL.
3. Observe level indicator to determine whether machine must be leveled prior to lifting load.
4. Move boom/attachment to 4 ft (1,2 m) off ground.
(AUS - Move boom so forks are no more than 300 mm (11.8 in) above ground surface.)

Important things to remember:

- Never raise the boom/attachment more than 4 ft (1,2 m) above ground unless telehandler is level.
(AUS - Never raise the forks more than 300 mm (11.8 in) above ground surface unless telehandler is level.)
- The combination of side tilt and load could cause the telehandler to tip over.

Section 4 - Operation

Placing a Load

Before placing any load be sure that:

- The landing point can safely support the weight of the load.
- The landing point is level; front to back and side to side.
- Use the load chart to determine safe boom extension range. See *“Use of the Load Chart”* on page 5-5.
- Align forks at the level load is to be placed, then extend boom slowly until load is just above area where it is to be placed.
- Lower the boom until the load rests in position and the forks are free to retract.

Disengaging a Load

Once the load has been placed safely at the landing point, proceed as follows:

1. With the forks free from the weight of the load, the boom can be retracted and/or the telehandler can be backed away from under the load if surface will not change level condition of telehandler.
2. Lower the carriage.
3. The telehandler can now be driven from the landing location to continue work.

4.4 OPERATING WITH A SUSPENDED LOAD

Lift Load Safely

- You must know the weight and load center of every load you lift. If you are not sure of the weight and load center, check with your supervisor or with the supplier of the material.



WARNING

TIP OVER HAZARD. Exceeding lift capacity of the telehandler could damage the equipment and/or cause tip over.

- Know the rated load capacities (refer to Section 5) of the telehandler to determine the operating range in which you can safely lift, transport and place a load.

Picking Up a Suspended Load

- Note the conditions of the terrain. Adjust travel speed and reduce amount of load if conditions warrant.
- Avoid lifting double-tiered loads.
- Make sure load is clear of any adjacent obstacles.
- **NEVER** operate telehandler without a proper and legible load chart in the operator cab for the telehandler/attachment combination you are using.
- Only use approved lifting devices rated for the lifting of the load.
- Identify the proper lifting points of the load, taking into consideration the center of gravity and load stability.
- Ensure to always properly tether loads to restrict movement.
- Refer to *“Use of the Load Chart”* on page 5-5 for proper lifting guidelines in addition to the appropriate load chart in the operator cab.

Section 4 - Operation

Transporting a Suspended Load



OZ3160

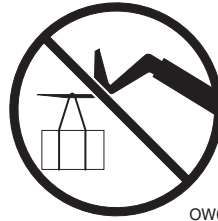

OW0130

- Travel in accordance with the requirements set forth in Section 1 - General Safety Practices and Section 5- Attachments.
- For additional requirements, refer to the appropriate load chart in the operator cab.

Important things to remember:

- Ensure the boom is fully retracted.
- Never raise the load more than 11.8 in (300 mm) above ground surface or the boom more than 45°.
- The combination of frame leveling and load could cause the telehandler to tip over.
- The guide persons and operator must remain in constant communication (verbal or hand) and be in visual contact with the operator at all times.
- Never place the guide persons between the suspended load and the telehandler.
- Only transport the load at walking speed, 0.9 mph (0.4 m/s), or less.

Leveling Procedure

1. Position machine in best location to lift or place load.
2. Apply parking brake and move transmission control lever to NEUTRAL.
3. Observe level indicator to determine whether machine must be leveled prior to lifting load.
4. Move boom so load is no more than 11.8 in (300 mm) above ground surface and boom/or boom is raised no more than 45°.

Placing a Suspended Load

Before placing any load be sure that:

- The landing point can safely support the weight of the load.
- The landing point is level; front to back and side to side.
- Use the load chart to determine safe boom extension range. “*Use of the Load Chart*” on page 5-5
- Align load at the level load is to be placed, then position boom slowly until load is just above area where it is to be placed.
- Ensure that the guide persons and operator remain in constant communication (verbal or hand) when placing the load.

Disengaging a Suspended Load

- Never place the guide persons between the suspended load and the telehandler.
- Once at load destination, bring telehandler to a complete stop and apply park brake prior to disengagement of lifting devices and tethers.

Section 4 - Operation

4.5 LOADING AND SECURING FOR TRANSPORT

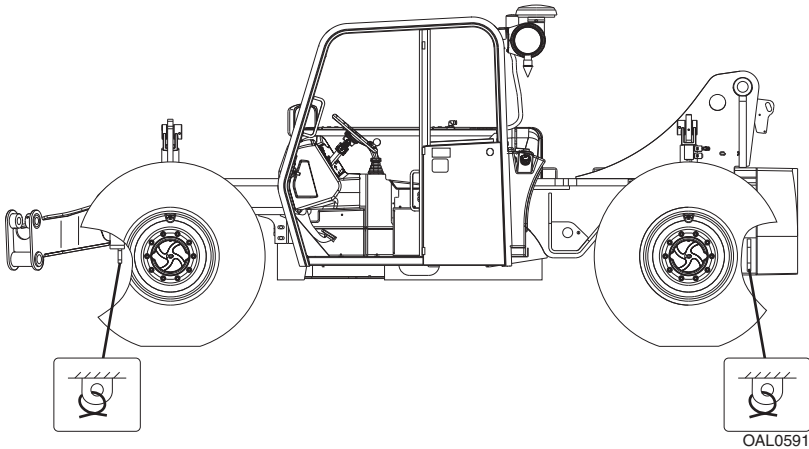

Tiedown

1. Level the telehandler prior to loading.
2. Using a spotter, load the telehandler with boom as low as possible.
3. Once loaded, apply parking brake and lower boom until boom or attachment is resting on deck. Move all controls to "Neutral," stop engine and remove ignition key.
4. Secure machine to deck by passing chains through the designated tie down points as shown in the figure.
5. Do not tie down front of boom.

Note: The user assumes all responsibility for choosing the proper method of transportation and tie-down devices, making sure the equipment used is capable of supporting the weight of the vehicle being transported and that all manufacturer's instructions and warnings, regulations and safety rules of their employer, the Department of Transportation and/or any other local, state or federal/provincial laws are followed.



WARNING

TELEHANDLER SLIDE HAZARD. Before loading telehandler for transport, make sure deck, ramps and telehandler wheels are free of mud, snow and ice. Failure to do so could cause telehandler to slide.

Lifting

- When lifting machine, it is very important that the lifting device and equipment is attached only to designated lifting points. If machine is not equipped with lifting lugs contact JLG Product Safety for information.
- Make adjustments to the lifting device and equipment to ensure the machine will be level when elevated. The machine must remain level at all times while being lifted.
- Ensure that the lifting device and equipment is adequately rated and suitable for the intended purpose. See Section 9 - Specifications for machine weight or weigh machine.
- Remove all loose items from machine prior to lifting.
- Lift machine with smooth, even motion. Set machine down gently. Avoid quick or sudden motions that could cause shock loads to machine and/or lifting devices.

This Page Intentionally Left Blank

SECTION 5 - ATTACHMENTS

5.1 APPROVED ATTACHMENTS

To determine if an attachment is approved for use on the specific telehandler you are using, perform the following prior to installation.

- The attachment type, weight, dimensions and load center must be equal to or less than the data shown on a load chart located in the operator cab.
- The model on the load chart must match the model telehandler being used.
- Hydraulically powered attachments must only be used on machines equipped with auxiliary hydraulics.

If any of the above conditions are not met, do not use the attachment. The telehandler may not be equipped with the proper load chart or the attachment may not be approved for the model telehandler being used. Contact JLG or the local Caterpillar dealer for further information.

5.2 UNAPPROVED ATTACHMENTS

Do not use unapproved attachments for the following reasons:

- Range and capacity limitations for “will fit,” homemade, altered, or other non-approved attachments cannot be established.
- An overextended or overloaded telehandler can tip over with little or no warning and cause serious injury or death to the operator and/or those working nearby.
- The ability of a non-approved attachment to perform its intended function safely cannot be assured.



WARNING

Use only approved attachments. Attachments which have not been approved for use with your telehandler could cause machine damage or an accident.

Section 5- Attachments

5.3 JLG SUPPLIED ATTACHMENTS

Note: Part numbers referenced are for inspection and identification purposes only. Refer to the Parts Manual when ordering replacement parts.

Attachment	Part Number	Applicable Model	
		TL642C	TL943C
Carriage, 50 in (1270 mm)	301-9757	X	X
Carriage, 72 in (1829 mm)	301-9758	X	X
Side Shift Carriage, 48 in (1220 mm)	314-8479	X	X
Rotate/Side Tilt Carriage, 50 in (1270 mm)	309-4315	X	X
Rotate/Side Tilt Carriage, 72 in (1829 mm)	309-4316	X	X
100° Swing Carriage, 72 in (1829 mm)	318-9222	X	X
Dual Fork Positioning Carriage, 50 in (1270 mm)	397-6838	X	X
Fork, Pallet 2.36x4x48 in (60x100x1220 mm)	301-9755	X	X
Fork, Pallet 2.36x5x48 in (60x125x1220 mm)	301-9753	X	X
Fork, Lumber 2.36x6x60 in (60x150x1539 mm)	301-9754	X	X
Fork, Lumber 1.75x7x60 in (45x180x1539 mm)	301-9756	X	X
Fork, Dual Taper 2x6x72 in (50x150x1829 mm)	311-2854	X	X
Fork, Block 2x2x48 in (50x50x1220 mm)	301-9752	X	X
Fork Extension, 90 in (2286 mm)	397-6114	X	X
Hook, Fork Mounted	321-0556	X	X
Winch, Boom Head-Mounted	305-3768	X	X
Platform, Fork Mounted (ASME)	343-9736	X	X
Platform, Fork Mounted (ASME - French)	343-9738	X	X
Platform, Fork Mounted (ISO)	343-9737	X	X
Bucket, GP 1.3 yd ³ (1,0 m ³)	163-4261	X	X
Bucket, MP 1.3 yd ³ (1,0 m ³)	163-4265	X	X
Bucket, Light Material 1.9 yd ³ (1,5 m ³)	186-5838	X	X
Coupler Mounted Hook	169-6460	X	X
Truss Boom, 13.1 ft (4 m)	169-3945	X	X
Material Handling Arm, 6.7-13.2 ft (2-4 m)	229-9714	X	X

This Page Intentionally Left Blank

Section 5- Attachments

5.4 TELEHANDLER/ATTACHMENT/FORK CAPACITY

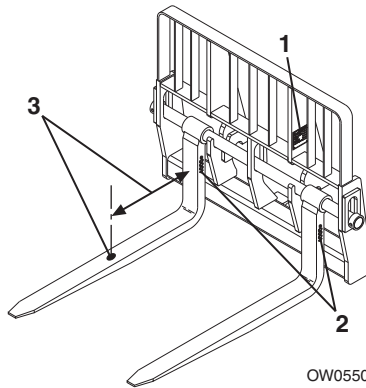

Prior to installing the attachment verify it is approved and the telehandler is equipped with the proper load chart. See “*Approved Attachments*” on page 5-1.

To determine the maximum capacity of the telehandler and attachment, use the **smallest** of the following capacities:

- Capacity stamped on the attachment identification plate (1).
- Fork capacities and load centers are stamped on the side of each fork (2) (if equipped). This rating specifies the maximum load capacity that the individual fork can safely carry at the maximum load center (3). Total attachment capacity is multiplied by the number of forks on the attachment (if equipped), up to the maximum capacity of the attachment.
- Maximum capacity as indicated on the proper load chart. See “*Approved Attachments*” on page 5-1.
- When the load rating of the telehandler differs from the capacity of the forks or attachment, the lower value becomes the overall load capacity.

Use the proper load chart to determine maximum capacity at various machine configurations. Lifting and placing a load may require use of more than one load chart based on machine configuration.

Other than block forks, all forks should be used in matched pairs, block forks used in matched sets.



WARNING

Never use an attachment without the appropriate JLG approved load chart installed on the telehandler.

5.5 USE OF THE LOAD CHART

To properly use the load chart (see page 5-6), the operator must first determine and/or have the following:

1. An approved attachment. See “*Approved Attachments*” on page 5-1.
2. The proper Load Chart(s).
3. Weight of the load being lifted.
4. Load placement information:
 - a. HEIGHT where the load is to be placed.
 - b. DISTANCE from the front tires of the telehandler where the load is to be placed.
5. On the load chart, find the line for the height and follow it over to the distance.
6. The number in the load zone where the two cross is the maximum capacity for this lift. If the two cross at a division between zones, the smaller number must be used.

The number in the load zone must be equal to or greater than the weight of the load to be lifted. Determine the limits of the load zone on the load chart and keep within these limits.

Capacity Indicator Locations

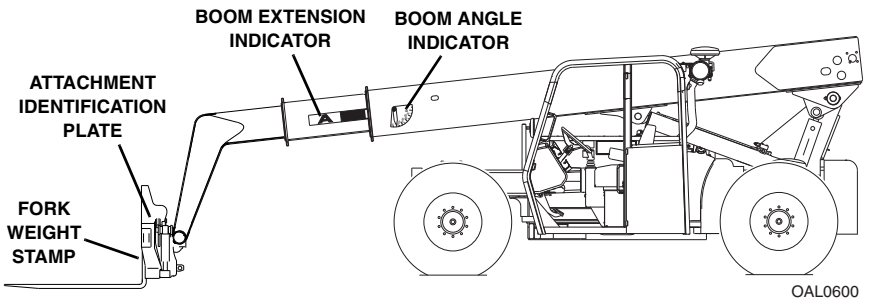

Section 5- Attachments

Sample Load Chart

This Load Chart may be used with this model ONLY. The telehandler model is indicated on the boom or chassis. Model XXXXX is used for demonstration purposes only.

Attachment type, weight and dimensions must be equal to or less than the data shown.

XXXXX

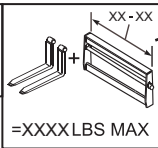

2

Boom Angle

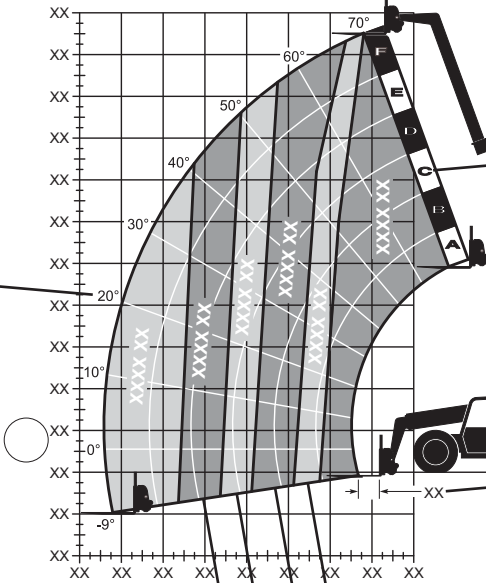

Boom Extension Indicator (arc)

Load center must be equal to or less than value shown.

ANSI / ITSDF B56.6-2005

OAL1071

Load zones indicate the maximum weight that may be safely lifted.

Note: This is a sample load chart **only!** **DO NOT** use this chart, use the one located in your operator cab.



WARNING

TIP OVER HAZARD. All loads shown on rated load chart are based on machine being on firm ground with frame level (see page 4-9); the forks being positioned evenly on carriage; the load being centered on forks; proper size tires being properly inflated; and the telehandler being in good operating condition.

Section 5- Attachments

To identify the proper load chart on telehandlers equipped with outriggers, refer to the following icons which may be located on the load chart.

- Use when lifting a load with outriggers up.



OAL1090

- Use when lifting a load with outriggers down.

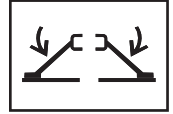

OAL1100

Section 5- Attachments

Example

A contractor owns a model xxxxx telehandler with a fork carriage. He knows this attachment may be used with his model since:

- The attachment style, weight, dimensions and load center match the attachment data on the load chart.
- The load chart is clearly marked for model xxxxx and corresponds with machine configuration being used.

Below are examples with various conditions the contractor may encounter and whether or not the load may be lifted.

	Load Weight	Distance	Height	OK to Lift
1	2500 lb (1134 kg)	16 ft (4,9 m)	12 ft (3,6 m)	Yes
2	2000 lb (907 kg)	21 ft (6,4 m)	20 ft (6,1 m)	NO
3	4000 lb (1814 kg)	10 ft (3,0 m)	18 ft (5,5 m)	Yes
4	6500 lb (2948 kg)	8 ft (2,4 m)	28 ft (8,5 m)	NO

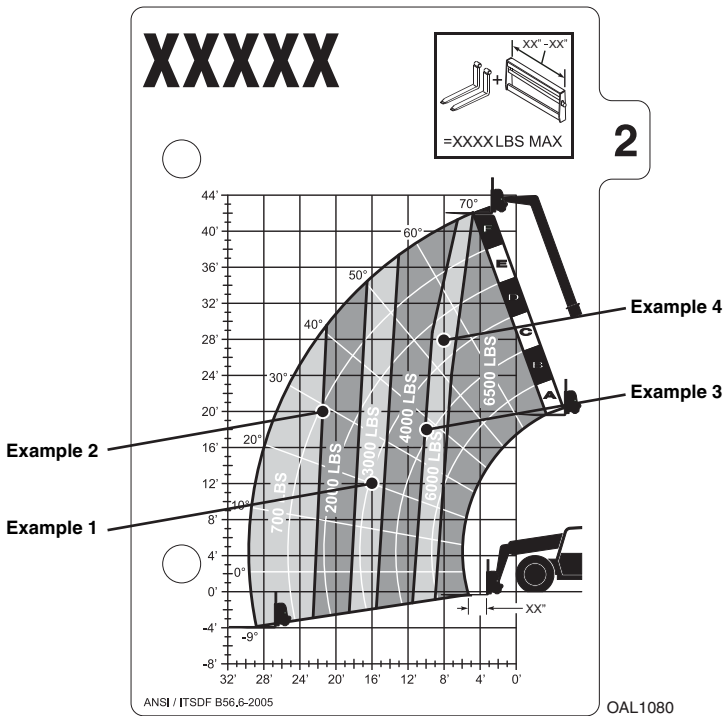

Note: This is a sample load chart **only!** **DO NOT** use this chart, use the one located in your operator cab.

5.6 ATTACHMENT INSTALLATION

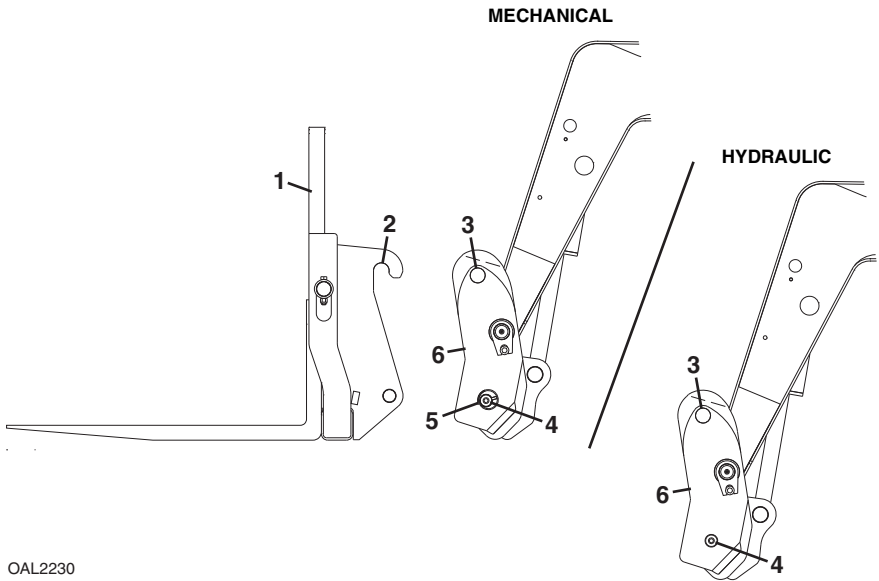

OAL2230

1. Attachment
2. Attachment Pin Recess
3. Attachment Pin
4. Lock Pin
5. Retainer Pin (mechanical quick coupler)
6. Quick Coupler (attachment tilt control in cab, see page 3-10)



WARNING

CRUSH HAZARD. Always be certain that carriage or attachment is properly positioned on boom and is secured by lock pin and retainer pin. Failure to ensure proper installation could permit carriage/attachment/load to disengage.

Section 5- Attachments

Mechanical Quick Coupler

This installation procedure is designed for one-person operation. Prior to exiting cab, perform “*Shut-Down Procedure*” on page 4-4.

1. Tilt quick coupler forward to provide clearance.

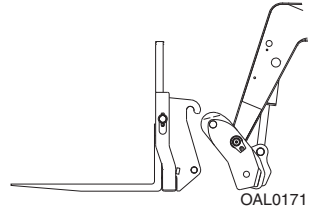

2. Align attachment pin with recess in attachment. Raise boom slightly to engage attachment pin in recess.

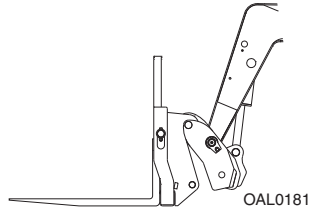

3. Check to be sure lock pin and retainer pin are out. Tilt quick coupler back to engage attachment.

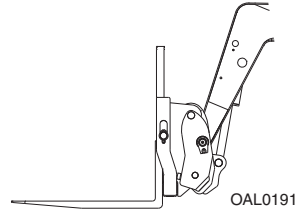

4. Insert lock pin and secure with retainer pin.

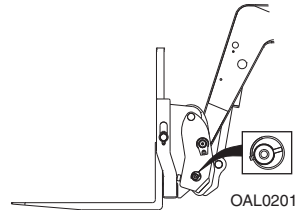

5. If attachment is equipped, connect auxiliary hydraulic hoses. See “*Hydraulic Operated Attachment*” on page 5-12.

Hydraulic Quick Coupler

This installation procedure is designed for one-person operation.

1. Tilt quick coupler forward to provide clearance.

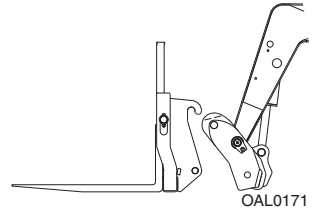

2. Align attachment pin with recess in attachment. Raise boom slightly to engage attachment pin in recess.

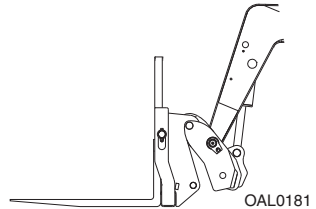

3. Check to be sure lock pin is disengaged. Tilt quick coupler back to engage attachment.

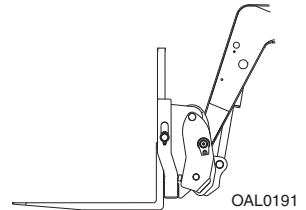

4. TL642C - Unlock the quick coupler switch (1), press and hold. At the same time push auxiliary hydraulic joystick (2) up to engage lock pin. Push auxiliary hydraulic joystick down to disengage lock pin.

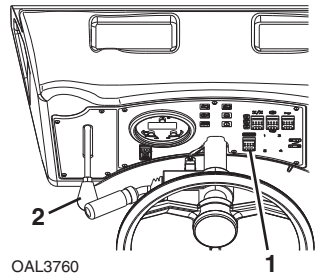

- TL943C - Press and hold quick coupler switch (1). At the same time push the roller switch (3) down to engage lock pin or push roller switch up to disengage lock pin.

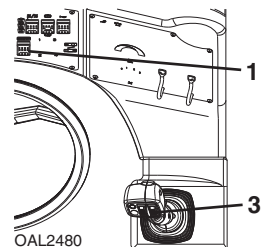

Section 5- Attachments

5. Raise boom to eye level and visually check that the lock pins protrude through the holes on both sides of the quick coupler. If the lock pins do not protrude through the holes, place the attachment on the ground and return to step 2.

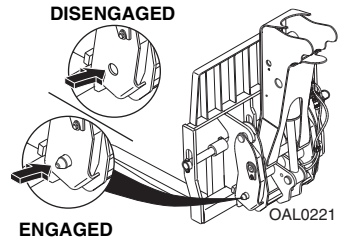

6. If attachment is equipped, connect auxiliary hydraulic hoses. See "Hydraulic Operated Attachment" on page 5-12.

5.7 HYDRAULIC OPERATED ATTACHMENT

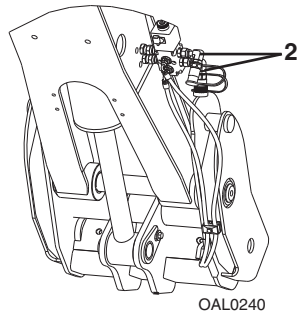
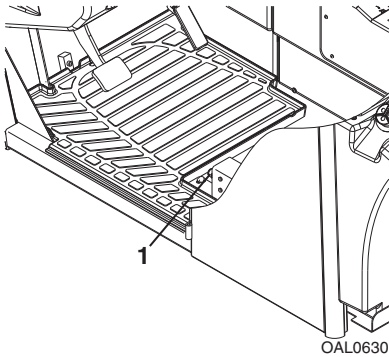

1. Install attachment (see page 5-9).
2. Lower attachment to ground and perform "Shut-Down Procedure" on page 4-4.
3. Press decompression valve button (1) to relieve auxiliary hydraulic pressure.
4. Connect attachment hoses to both auxiliary fittings (2).

5.8 ADJUSTING/MOVING FORKS

Carriages may have different locations where forks can be positioned. Two different methods can be used for repositioning, depending upon the carriage structure.

Note: Apply a light coating of appropriate lubricant to ease sliding of forks or fork bar.

To slide forks:

1. Ensure attachment is properly installed. See "Attachment Installation" on page 5-9.
2. Elevate attachment to approximately 5 ft (1,5 m) and tilt carriage forward until fork heel is free from attachment.
3. Stand at the side of the carriage. To slide fork toward the center of the carriage, push the fork near the fork eye. To slide fork toward the edge of the carriage, pull the fork near the fork eye. To avoid pinching, do not place fingers or thumb between the fork and carriage structure.

If removing fork bar is necessary:

1. Rest forks on ground.
2. Remove fork bar.
3. Reposition forks.
4. Reinstall the fork bar and fork bar retaining mechanism(s).

Section 5- Attachments

5.9 ATTACHMENT OPERATION

- Capacities and range limits for the telehandler change depending on the attachment in use.
- Separate attachment instructions must be kept in manual holder in cab with this Operation & Maintenance Manual. An additional copy must be kept with the attachment if it is equipped with a manual holder.

NOTICE

EQUIPMENT DAMAGE. Some attachments may contact front tires or machine structure when the boom is retracted and the attachment is rotated. Improper use of attachment may result in attachment or machine structural damage.

NOTICE

EQUIPMENT DAMAGE. Avoid contact with any structure or object when lifting a load. Maintain clearance around boom structure and load. Failure to maintain clearance may result in attachment or machine structural damage.

This Page Intentionally Left Blank

Section 5- Attachments

Carriage with Forks

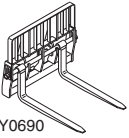

Use Carriage Attachment Load Chart

To determine maximum capacity, refer to "Telehandler/ Attachment/Fork Capacity" on page 5-4.

Suspend loads in accordance with requirements set forth in Section 1 - General Safety Practices.

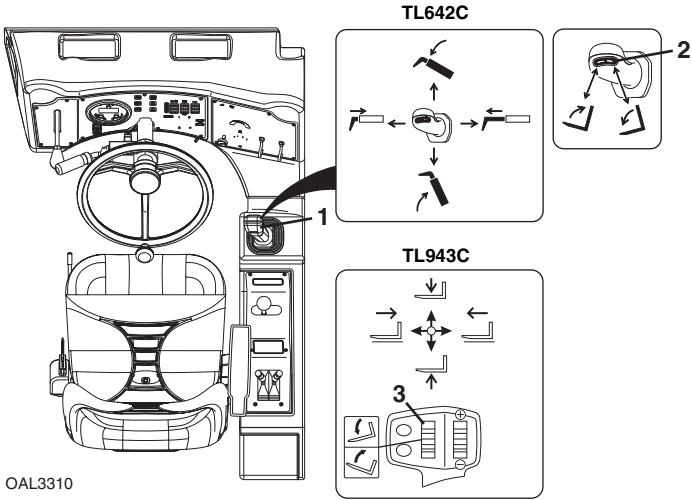

The joystick (1) controls lift/lower and extend/retract movement of the boom.

TL642C - The tilt switch (2) controls fork tilt.

- Press the left side of the switch to tilt up.
- Press the right side of the switch to tilt down.

TL943C - The tilt roller switch (3) controls fork tilt.

- Press roller switch down to tilt up.
- Press roller switch up to tilt down.

Installation Procedure:

- Refer to “Attachment Installation” on page 5-9.

Operation:

When utilizing lifting lug, weight of rigging must be included as part of total load lifted

Equipment Damage Precautions:

- Do not use forks as a lever to pry material. Excessive prying forces could damage forks or machine structure.
- Do not attempt to lift loads that are attached or connected to another object.

Section 5- Attachments

Side Shift Carriage

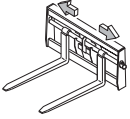

OAL1540

Use Side Shift Carriage Load Chart

To determine maximum capacity, refer to "Telehandler/Attachment/Fork Capacity" on page 5-4.

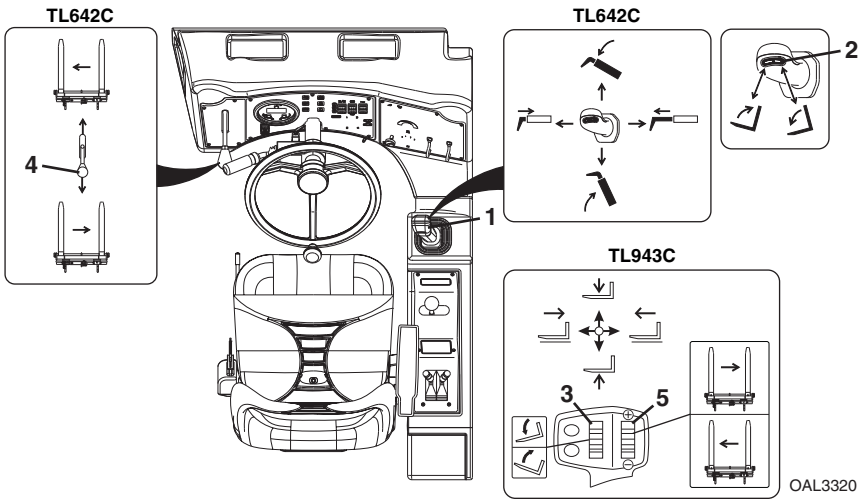

The joystick (1) controls lift/lower and extend/retract movement of the boom.

TL642C - The tilt switch (2) controls fork tilt.

- Press the left side of the switch to tilt up.
- Press the right side of the switch to tilt down.

TL943C - The tilt roller switch (3) controls fork tilt.

- Press roller switch down to tilt up.
- Press roller switch up to tilt down.

To Side Shift:

TL642C - The auxiliary hydraulic joystick (4) controls carriage side shift.

- Move joystick up to shift left.
- Move joystick down to shift right.

TL943C - The auxiliary hydraulic roller switch (5) controls carriage side shift.

- Press roller switch down to shift left.
- Press roller switch up to shift right.

Installation Procedure:

- Refer to “Attachment Installation” on page 5-9.



WARNING

CRUSH HAZARD. Do not use side shift to push or pull objects or load. Failure to comply could cause object or load to fall.

Equipment Damage Precautions:

- Do not use forks as a lever to pry material. Excessive prying forces could damage forks or machine structure.
- Do not attempt to lift loads that are attached or connected to another object.

Section 5- Attachments

Rotate/Side Tilt Carriage

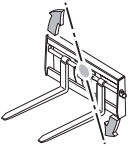

OAL1550

Use Rotate/Side Tilt Carriage Load Chart

To determine maximum capacity, refer to "Telehandler/Attachment/Fork Capacity" on page 5-4.

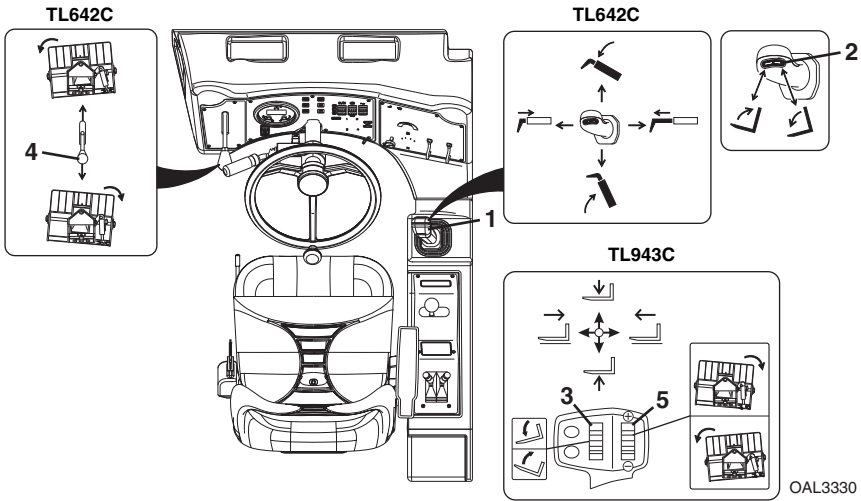

OAL3330

The joystick (1) controls lift/lower and extend/retract movement of the boom.

TL642C - The tilt switch (2) controls fork tilt.

- Press the left side of the switch to tilt up.
- Press the right side of the switch to tilt down.

TL943C - The tilt roller switch (3) controls fork tilt.

- Press roller switch down to tilt up.
- Press roller switch up to tilt down.

To Rotate:

TL642C - The auxiliary hydraulic joystick (4) controls carriage rotation.

- Move joystick up to rotate left.
- Move joystick down to rotate right.

TL943C - The auxiliary hydraulic roller switch (5) controls carriage rotation.

- Press roller switch down to rotate left.
- Press roller switch up to rotate right.

Installation Procedure:

- Refer to “Attachment Installation” on page 5-9.



WARNING

CRUSH HAZARD. Do not use rotation to push or pull objects or load. Failure to comply could cause object or load to fall.

Equipment Damage Precautions:

- Do not use forks as a lever to pry material. Excessive prying forces could damage forks or machine structure.
- Do not attempt to lift loads that are attached or connected to another object.

Section 5- Attachments

Swing Carriage

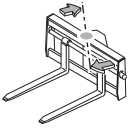

OU2150

Use Swing Carriage Load Chart

To determine maximum capacity, refer to "Telehandler/Attachment/Fork Capacity" on page 5-4.

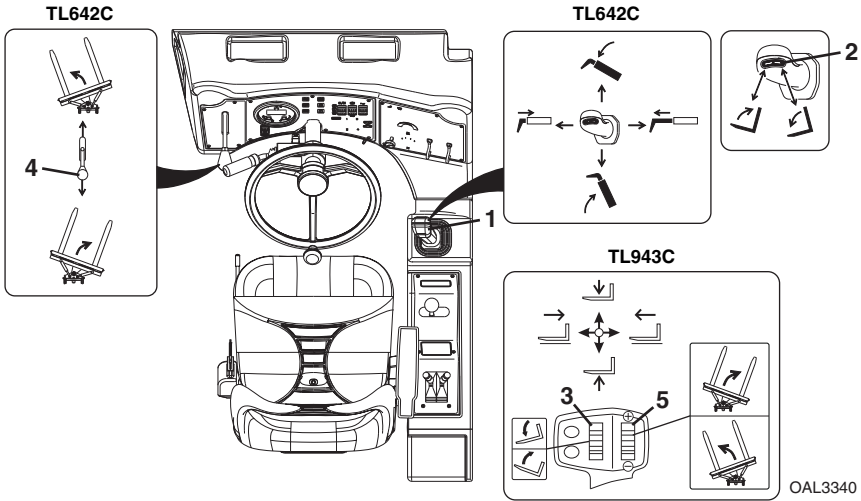

The joystick (1) controls lift/lower and extend/retract movement of the boom.

TL642C - The tilt switch (2) controls fork tilt.

- Press the left side of the switch to tilt up.
- Press the right side of the switch to tilt down.

TL943C - The tilt roller switch (3) controls fork tilt.

- Press roller switch down to tilt up.
- Press roller switch up to tilt down.

To Swing:

TL642C - The auxiliary hydraulic joystick (4) controls carriage swing.

- Move joystick up to swing left.
- Move joystick down to swing right.

TL943C - The auxiliary hydraulic roller switch (5) controls carriage swing.

- Press roller switch down to swing left.
- Press roller switch up to swing right.

Installation Procedure:

- Refer to “Attachment Installation” on page 5-9.



WARNING

CRUSH HAZARD. Always level forks (horizontally) and telehandler frame before swinging load to side. Swinging unlevel forks could cause load to slide off forks.



WARNING

CRUSH HAZARD. Do not use swing carriage to push or pull objects or load. Failure to comply could cause object or load to fall.



WARNING

CRUSH HAZARD. Use retaining pin (if equipped) for locking swing frame to fixed frame when carrying loads greater than 5000 lb. Failure to comply could cause object or load to fall.

Operation:

- To drive with a load, keep forks pointed forward and travel in accordance with the requirements set forth in Section 1 - General Safety Practices.

Equipment Damage Precautions:

- Do not use forks as a lever to pry material. Excessive prying forces could damage forks or machine structure.
- Do not attempt to lift loads that are attached or connected to another object.

Section 5- Attachments

Dual Fork Positioning Carriage

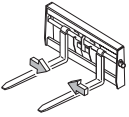

OZ3670

Use Dual Fork Positioning Carriage Load Chart

To determine maximum capacity, refer to "Telehandler/
Attachment/Fork Capacity" on page 5-4.

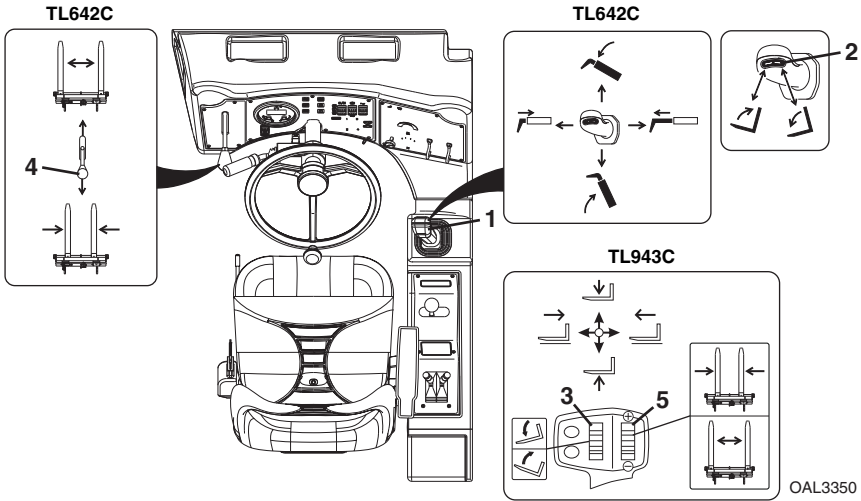

The joystick (1) controls lift/lower and extend/retract movement of the boom.

TL642C - The tilt switch (2) controls fork tilt.

- Press the left side of the switch to tilt up.
- Press the right side of the switch to tilt down.

TL943C - The tilt roller switch (3) controls fork tilt.

- Press roller switch down to tilt up.
- Press roller switch up to tilt down.

To Fork Position:

TL642C - The auxiliary hydraulic joystick (4) controls fork position.

- Move joystick up to shift forks out.
- Move joystick down to shift forks in.

TL943C - The auxiliary hydraulic roller switch (5) controls fork position.

- Press roller switch down to shift forks out.
- Press roller switch up to shift forks in.

Installation Procedure:

- Refer to “Attachment Installation” on page 5-9.



WARNING

CRUSH HAZARD. Do not use fork positioning to push or pull objects or load. Failure to comply could cause object or load to fall.

Operation:

- Travel in accordance with the requirements set forth in Section 1 - General Safety Practices.

Equipment Damage Precautions:

- Do not use forks as a lever to pry material. Excessive prying forces could damage forks or machine structure.
- Do not attempt to lift loads that are attached or connected to another object.

Section 5- Attachments

Fork Extension

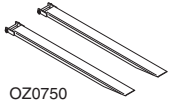

Use Appropriate Carriage Attachment Capacity Chart

To determine maximum capacity, refer to “*Telehandler/Attachment/Fork Capacity*” on page 5-4. The maximum capacity of the carriage when equipped with fork extensions may be reduced to the capacity indicated on the fork extensions. If the load exceeds the capacity of the fork extension contact JLG to obtain forks and/or fork extensions of the proper load rating and length.

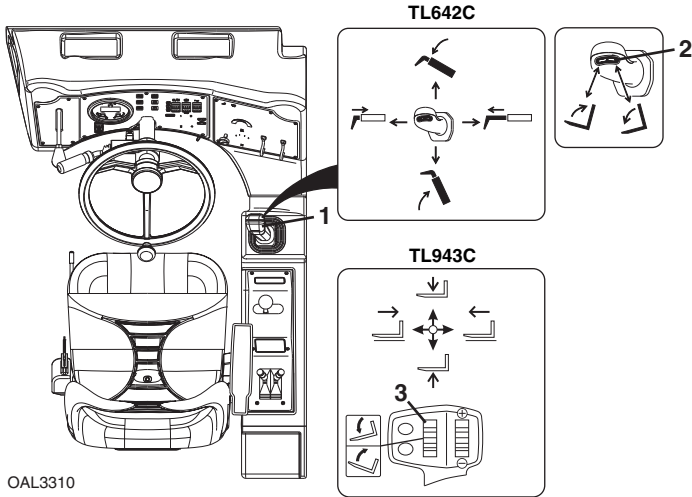

The joystick (1) controls lift/lower and extend/retract movement of the boom.

TL642C - The tilt switch (2) controls fork tilt.

- Press the left side of the switch to tilt up.
- Press the right side of the switch to tilt down.

TL943C - The tilt roller switch (3) controls fork tilt.

- Press roller switch down to tilt up.
- Press roller switch up to tilt down.

Installation Procedure:

- Ensure carriage is properly installed. Refer to “*Attachment Installation*” on page 5-9.
- Ensure length and cross section of the parent fork arm is equal to or exceeds the parent fork arm blade length stamped into the fork extension.
- Secure the fork extensions to the forks by sliding the fork extensions onto the parent forks and install the retaining pin behind the vertical shank of the fork.

Operation:

- Heavy part of load must be against carriage backrest.
- Do not allow load center of gravity to be in front of tip of the supporting fork.
- Do not pick up a load or pry materials with tip of fork extensions.

Section 5- Attachments

Bucket

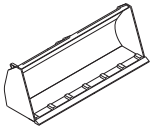

OZ0730

Use Bucket Load Chart

To determine maximum capacity, refer to "Telehandler/ Attachment/Fork Capacity" on page 5-4.

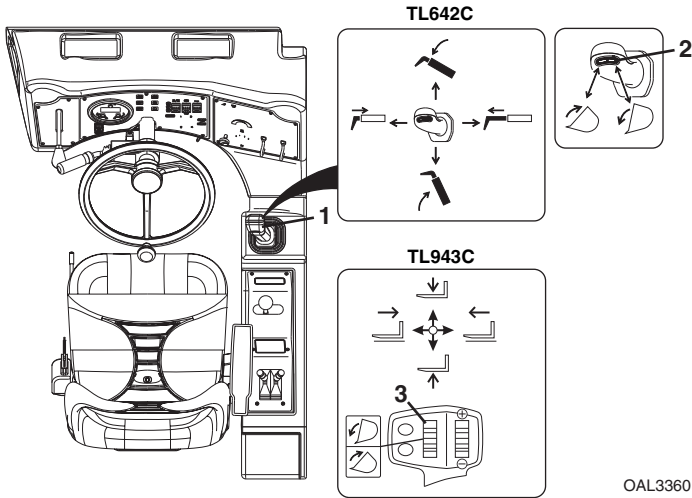

OAL3360

The joystick (1) controls lift/lower and extend/retract movement of the boom.

TL642C - The tilt switch (2) controls bucket tilt.

- Press the left side of the switch to tilt up.
- Press the right side of the switch to tilt down.

TL943C - The tilt roller switch (2) controls bucket tilt.

- Press roller switch down to tilt up.
- Press roller switch up to tilt down.

Installation Procedure:

- Refer to "Attachment Installation" on page 5-9.

Operation:

- Raise or lower boom to appropriate height for loading material from stockpile.
- Align telehandler with face of stockpile and drive slowly and smoothly into pile to load bucket.
- Tilt bucket up far enough to retain load and back away from pile.
- Travel in accordance with requirements set forth in Section 1 - General Safety Practices.
- Tilt bucket down to dump load.

Equipment Damage Precautions

- Except for lifting or dumping a load, the boom must be fully retracted for all bucket operations.
- Do not corner-load bucket. Distribute material evenly within the bucket. Bucket load charts are for evenly distributed loads only.
- Do not use bucket as a lever to pry material. Excessive prying forces could damage bucket or machine structure.
- Do not attempt to load material which is hard or frozen. This could cause severe damage to quick coupler or machine structure.
- Do not use bucket for "back dragging." This could cause severe damage to quick coupler and retraction cables/chains.

Section 5- Attachments

Multi-Purpose Bucket

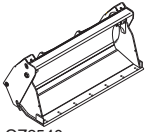

OZ2540

Use Multi-Purpose Bucket Load Chart

To determine maximum capacity, refer to "Telehandler/Attachment/Fork Capacity" on page 5-4.

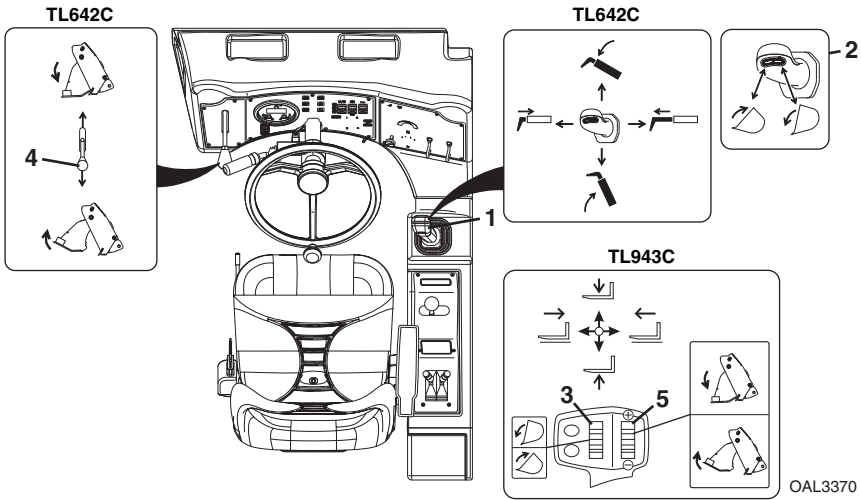

The joystick (1) controls lift/lower and extend/retract movement of the boom.

TL642C - The tilt switch (2) controls bucket tilt.

- Press the left side of the switch to tilt up.
- Press the right side of the switch to tilt down.

TL943C - The tilt roller switch (2) controls bucket tilt.

- Press roller switch down to tilt up.
- Press roller switch up to tilt down.

To Open/Close Bucket:

TL642C - The auxiliary hydraulic joystick (3) controls open/close movement of the bucket.

- Move joystick left to close.
- Move joystick right to open.

TL943C - The auxiliary hydraulic roller switch (3) controls open/close movement of the bucket.

- Press roller switch down to open.
- Press roller switch up to close.

Installation Procedure:

- Refer to "Attachment Installation" on page 5-9.

Operation:

- Raise or lower boom to appropriate height and close bucket for loading material from stockpile.
- Align telehandler with face of stockpile and drive slowly and smoothly into pile to load bucket.
- Tilt bucket up far enough to retain load and back away from pile.
- Travel in accordance with requirements set forth in Section 1 - General Safety Practices.
- Open bucket or tilt bucket down to dump load.

Equipment Damage Precautions

- Except for lifting or dumping a load, the boom must be fully retracted for all bucket operations.
- Do not corner-load bucket. Distribute material evenly within the bucket. Bucket load charts are for evenly distributed loads only.
- Do not use bucket as a lever to pry material. Excessive prying forces could damage bucket or machine structure.
- Do not attempt to load material which is hard or frozen. This could cause severe damage to quick coupler or machine structure.
- Do not use bucket for "back dragging." This could cause severe damage to quick coupler and retraction cables/chains.

Section 5- Attachments

Fork Mounted Hook

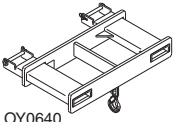

Use Appropriate Carriage Attachment Load Chart

To determine maximum capacity, refer to "Telehandler/ Attachment/Fork Capacity" on page 5-4.

Suspend loads in accordance with requirements set forth in Section 1 - General Safety Practices.

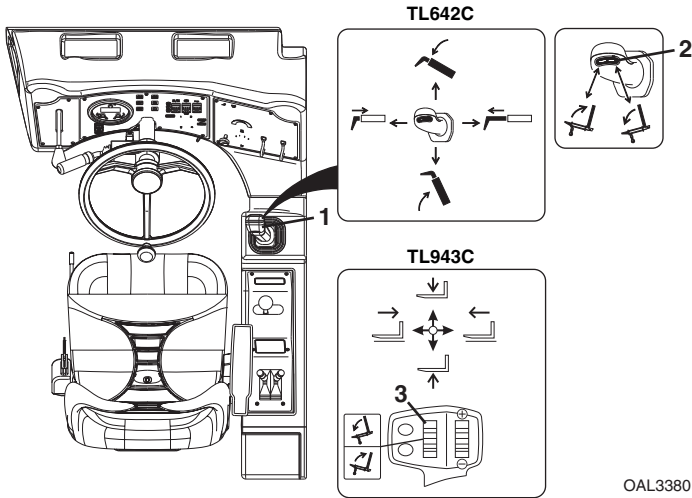

The joystick (1) controls lift/lower and extend/retract movement of the boom.

TL642C - The tilt switch (2) controls fork tilt.

- Press the left side of the switch to tilt up.
- Press the right side of the switch to tilt down.

TL943C - The tilt roller switch (3) controls fork tilt.

- Press roller switch down to tilt up.
- Press roller switch up to tilt down.

Installation Procedure:

- Ensure carriage is properly installed. Refer to "Attachment Installation" on page 5-9.
- Secure the fork mounted hook to the forks by sliding the fork mounted hook onto the parent forks and install the retaining pin behind the vertical shank of the fork.

Operation:

- Pallet or lumber forks of an appropriate load rating must be used. Do not use with cubing or block forks.
- Weight of fork mounted hook and rigging must be included as part of total load being lifted.
- Do not use with mast carriage attachment.
- Do not use fork mounted hook with attachments capable of rotating (i.e. side tilt and swing carriages) without disabling the rotation feature(s).

Section 5- Attachments

Coupler Mounted Hook



OAL1510

Use Coupler Mounted Hook Load Chart

To determine maximum capacity, refer to "Telehandler/Attachment/Fork Capacity" on page 5-4.

Suspend loads in accordance with requirements set forth in Section 1 - General Safety Practices.

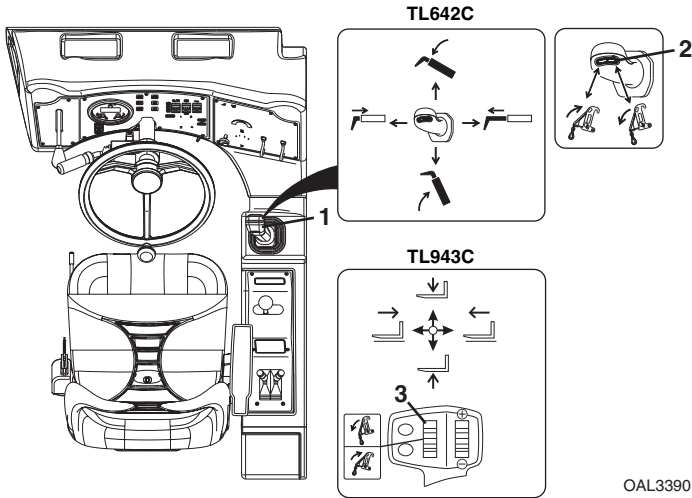

OAL3390

The joystick (1) controls lift/lower and extend/retract movement of the boom.

TL642C - The tilt switch (2) controls the coupler mounted hook tilt.

- Press the left side of the switch to tilt up.
- Press the right side of the switch to tilt down.

TL943C - The tilt roller switch (3) controls the coupler mounted hook tilt.

- Press roller switch down to tilt up.
- Press roller switch up to tilt down.

Installation Procedure:

- Refer to "Attachment Installation" on page 5-9.

Operation:

- Weight of rigging must be included as part of total load being lifted.

Truss Boom

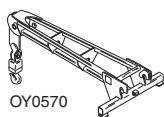

Use Truss Boom Load Chart

To determine maximum capacity, refer to “Telehandler/ Attachment/Fork Capacity” on page 5-4.

Suspend loads in accordance with requirements set forth in Section 1 - General Safety Practices.

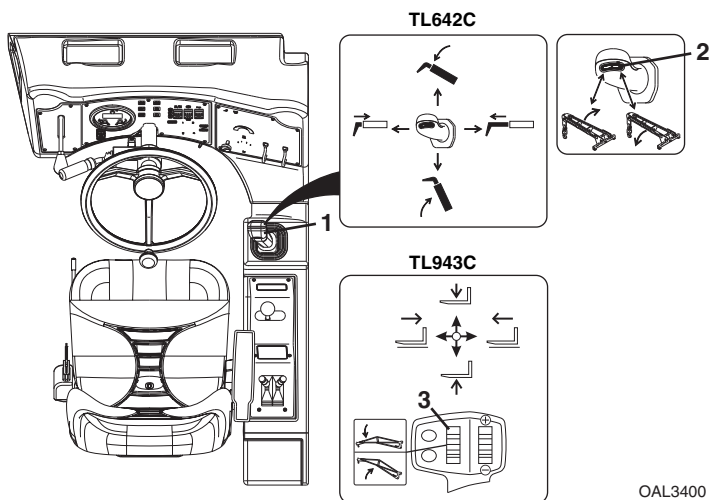

The joystick (1) controls lift/lower and extend/retract movement of the boom.

TL642C - The tilt switch (2) controls truss boom tilt.

- Press the left side of the switch to tilt up.
- Press the right side of the switch to tilt down.

TL943C - The tilt roller switch (3) controls truss boom tilt.

- Press roller switch down to tilt up.
- Press roller switch up to tilt down.

Installation Procedure:

- Refer to “Attachment Installation” on page 5-9.

Operation:

- Weight of rigging must be included as part of total load being lifted.

Section 5- Attachments

Personnel Work Platform - Fork Mounted

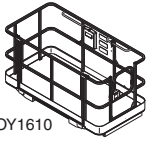

Use Appropriate Carriage Attachment Load Chart

To determine maximum capacity, refer to "Telehandler/Attachment/Fork Capacity" on page 5-4.

The operator and personnel in platform must read and understand the separate personnel work platform manual prior to installing and using a platform.

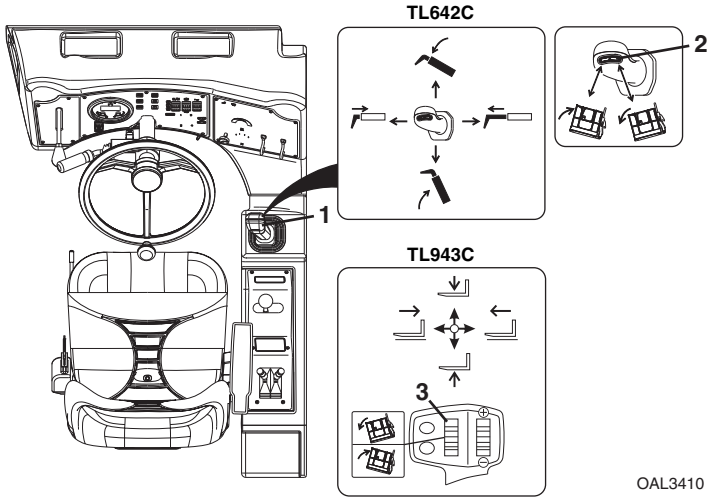

The joystick (1) controls lift/lower and extend/retract movement of the boom.

TL642C - The tilt switch (2) controls platform tilt.

- Press the left side of the switch to tilt up.
- Press the right side of the switch to tilt down.

TL943C - The tilt roller switch (3) controls platform tilt.

- Press roller switch down to tilt up.
- Press roller switch up to tilt down.

Installation Procedure:

- Ensure carriage is properly installed. Refer to “Attachment Installation” on page 5-9.
- Secure the fork mounted platform to the forks by sliding the fork mounted platform onto the parent forks and install the retaining pin behind the vertical shank of the fork.

Preparation and Setup:

1. Ensure the telehandler is on a firm surface and is level.
2. Engage the park brake. Blocking the wheels is also recommended.
3. Level the platform, both side to side (frame level) and front to back (attachment tilt).
4. Keep area under platform free from personnel.
5. When personnel are on platform, the operator must remain seated in cab with personnel in direct line of sight.
6. **DO NOT** lift or carry persons in a bucket or on forks.



WARNING

FALL HAZARD. Never tilt the platform forward, rearward, or level the machine when the platform is occupied.

Section 5- Attachments

Material Handling Arm

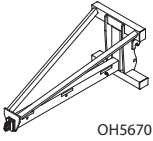

Use Material Handling Arm Load Chart

To determine maximum capacity, refer to "Telehandler/
Attachment/Fork Capacity" on page 5-4.

Suspend loads in accordance with requirements set forth in Section 1 - General Safety Practices.

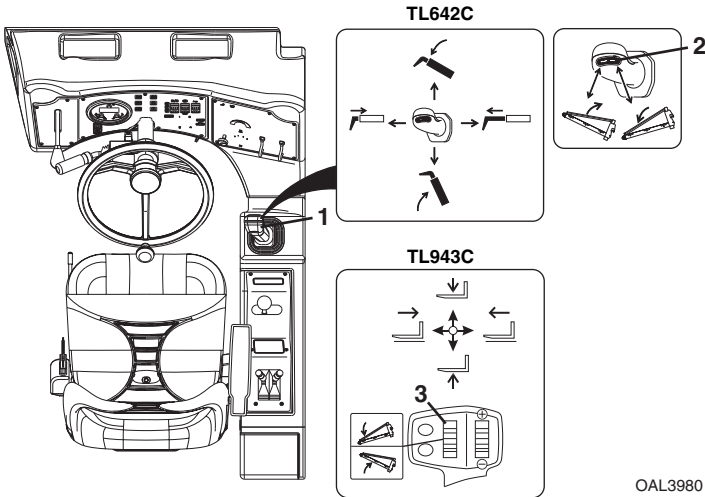

The joystick (1) controls lift/lower and extend/retract movement of the boom.

TL642C - The tilt switch (2) controls material handling arm tilt.

- Press the left side of the switch to tilt up.
- Press the right side of the switch to tilt down.

TL943C - The tilt roller switch (3) controls material handling arm tilt.

- Press roller switch down to tilt up.
- Press roller switch up to tilt down.

Installation Procedures

- Refer to “Attachment Installation” on page 5-9.
- Secure adjustable arm in desired position using the retaining pin.



WARNING

CRUSH HAZARD. Ensure adjustable arm is properly secured using the retaining pin prior to lifting load. Failure to comply could cause object or load to fall.

Operation:

- Weight of rigging must be included as part of total load being lifted.

Section 5- Attachments

Boom Head-Mounted Winch

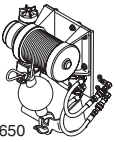

OY0650

Use Carriage Attachment Load Chart

To determine maximum capacity, refer to "Telehandler/Attachment/Fork Capacity" on page 5-4.

Suspend loads in accordance with requirements set forth in Section 1 - General Safety Practices.

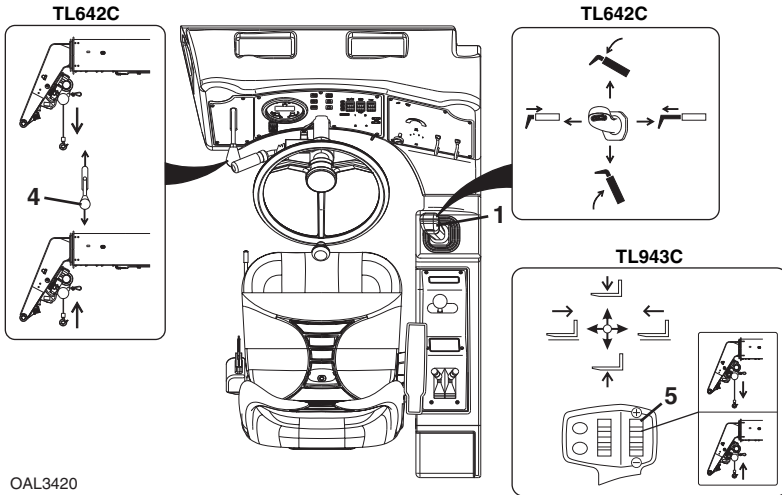

OAL3420

The joystick (1) controls lift/lower and extend/retract movement of the boom.

TL642C - The auxiliary hydraulic joystick (4) controls the winch.

- Move joystick left to lower cable.
- Move joystick right to raise cable.

TL943C - The auxiliary hydraulic roller switch (5) controls the winch.

- Press roller switch down to raise cable.
- Press roller switch up to lower cable.



WARNING

CRUSH HAZARD. Maintain a minimum of three wraps of wire rope on the cable drum at all times. Failure to comply could cause object or load to fall.

Operation:

- Weight of rigging must be included as part of total load being lifted.

SECTION 6 - EMERGENCY PROCEDURES

6.1 TOWING A DISABLED PRODUCT

The following information assumes the telehandler cannot be moved under its own power.

- Before moving the telehandler, read all of the following information to understand options available. Then select the appropriate method.
- Machine mounted retrieval devices provide suitable means to attach a tow rope, chain or tow bar only in the event the telehandler becomes stuck or disabled. Retrieval devices are not intended for trailer towing devices.
- The steering system permits manual steering if engine or power assist feature fails; however, **steering will be slow and will require much greater force.**
- **DO NOT** attempt to tow a telehandler that is loaded or the boom/attachment is raised above 4 ft (1,2 m).

Moving Short Distances

- If it is only necessary to move telehandler a short distance, less than 100 ft (30 m), it is permissible to use a vehicle of sufficient capacity to tow the unit with no previous preparation. Drive wheels will not roll.

Moving Longer Distances

- See Service Manual for details.

Contact the local Caterpillar dealer for specific instructions if neither of these methods are applicable.

Section 6 - Emergency Procedures

6.2 EMERGENCY LOWERING OF BOOM

In the event of total loss of engine power or hydraulic pump failure with an elevated load, the situation must be properly evaluated and dealt with on an individual basis. **Contact the local Caterpillar dealer for specific instructions.**

Secure the telehandler using the following procedures:

1. Clear the area around telehandler of all personnel.
2. Engage the parking brake. Place the transmission control lever in "NEUTRAL".
3. Block all four wheels.
4. Section off a large area under the boom with string or tape to restrict any personnel from entering this area.

6.3 EMERGENCY EXIT FROM ENCLOSED CAB

Fixed Window (if equipped)

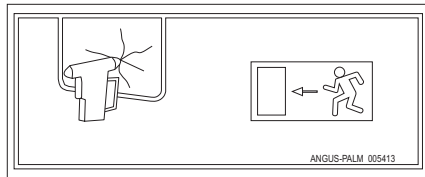

OWO740

- In an emergency, an escape hammer located directly below the rear window in an enclosed cab can be used to exit the telehandler.

Latch Window (if equipped)

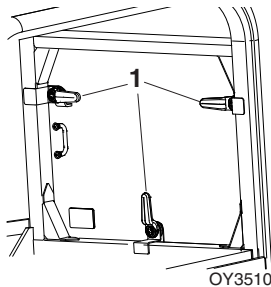

- In an emergency, rear window can be removed to exit the telehandler by releasing hand latches (1).

SECTION 7 - LUBRICATION AND MAINTENANCE

7.1 INTRODUCTION

Service the product in accordance with the maintenance schedule on the following pages.

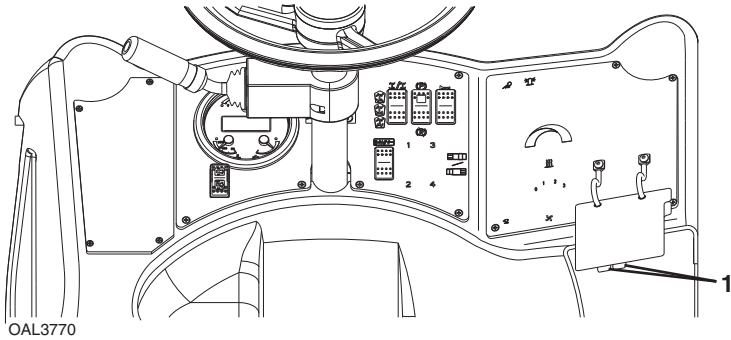

The lubrication and maintenance (2) charts contain instructions that must be followed to keep this product in good operating condition. The Operation & Maintenance Manual and Service Manual contain more detailed service information with specific instructions.

Clothing and Safety Gear

- Wear all the protective clothing and personal safety devices issued to you or called for by job conditions.
- **DO NOT** wear loose clothing or jewelry that can get caught on controls or moving parts.

Section 7 - Lubrication and Maintenance

7.2 GENERAL MAINTENANCE INSTRUCTIONS

Prior to performing any service or maintenance on the telehandler, follow the shut-down procedure on page 4-4 unless otherwise instructed. Ensure telehandler is level, for proper fluid readings.

- Clean lubrication fittings before lubricating.
- After greasing telehandler, cycle all functions several times to distribute lubricants. Perform this maintenance procedure without attachment installed.
- Apply a light coating of engine oil to all linkage pivot points.
- Intervals shown are for normal usage and conditions. Adjust intervals for abnormal usage and conditions.
- Check all lubricant levels when lubricant is cool, with the exception of the transmission fluid. For ease of filling hydraulic reservoir, use a funnel with a hose or flexible tube for best results.



WARNING

CUT/CRUSH/BURN HAZARD. Do not perform service or maintenance on the machine with the engine running with the exception of the transmission fluid level check.

7.3 SERVICE AND MAINTENANCE SCHEDULE

10, 1st 50 & 50 Hour Maintenance Schedule



EVERY

10 



Check Fuel Level



Air Filter Restriction Indicator



Check Engine Oil Level



Check Hydraulic Oil Level

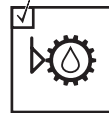

Check Transmission Oil Level



Check Fuel/Water Separator

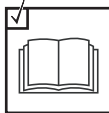

Additional Checks - Section 8

1st

50 



Check Wheel Lug Nut Torque

EVERY

50 



Drain Fuel/Water Separator

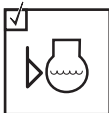

Check Engine Coolant Level

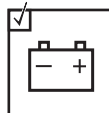

Check Battery



Check Washer Fluid Level (if equipped)



Lubrication Schedule

OAL3501

Section 7 - Lubrication and Maintenance

1st 250, 250 & 1st 500 Hour Maintenance Schedule



1st
250 

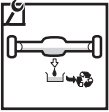

Change
Axle Oil

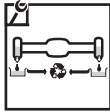

Change Wheel
End Oil

EVERY
250 

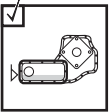

Check Transfer
Case Oil Level

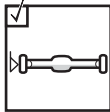

Check Axle
Oil Level

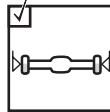

Check Wheel
End Oil Levels

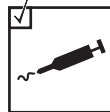

Lubrication
Schedule



Check
Fan Belt



Check Boom
Extend Chains

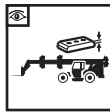

Check Boom
Wear Pads

1st
500 

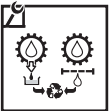

Change
Transmission
Oil & Filter

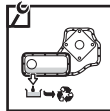

Change
Transfer Case
Oil

OAL3511

Section 7 - Lubrication and Maintenance

500, 1000 & 1500 Hour Maintenance Schedule



EVERY
500 



Change Engine
Oil and Filter



Change Fuel
Filters*



Check Wheel
Lug Nut
Torque

EVERY
1000 



Change
Transmission
Oil & Filter

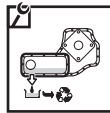

Change
Transfer Case
Oil

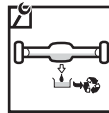

Change
Axle Oil

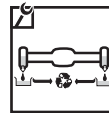

Change Wheel
End Oil



Change
Hydraulic Tank
Breather



Check
Air Intake
System



Check Boom
Retract Chains



Lubrication
Schedule

EVERY
1500 



Change
Engine Coolant

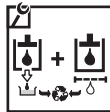

Change
Hydraulic
Fluid & Filters



Change
Crankcase
Vent Filter

OAL3081



Note: Fuel Filter Maintenance increases to 250 hours when operating in high altitudes. See page page 4-4.

Section 7 - Lubrication and Maintenance

3000 Hour Maintenance Schedule

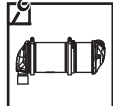

EVERY
3000 

 Change Fan Belt	 Service Diesel Particulate Filter	 Change Exhaust After Treatment Sensor
--	--	--

OAL3520

7.4 LUBRICATION SCHEDULES

50 Hour Lubrication Schedule

EVERY

50 

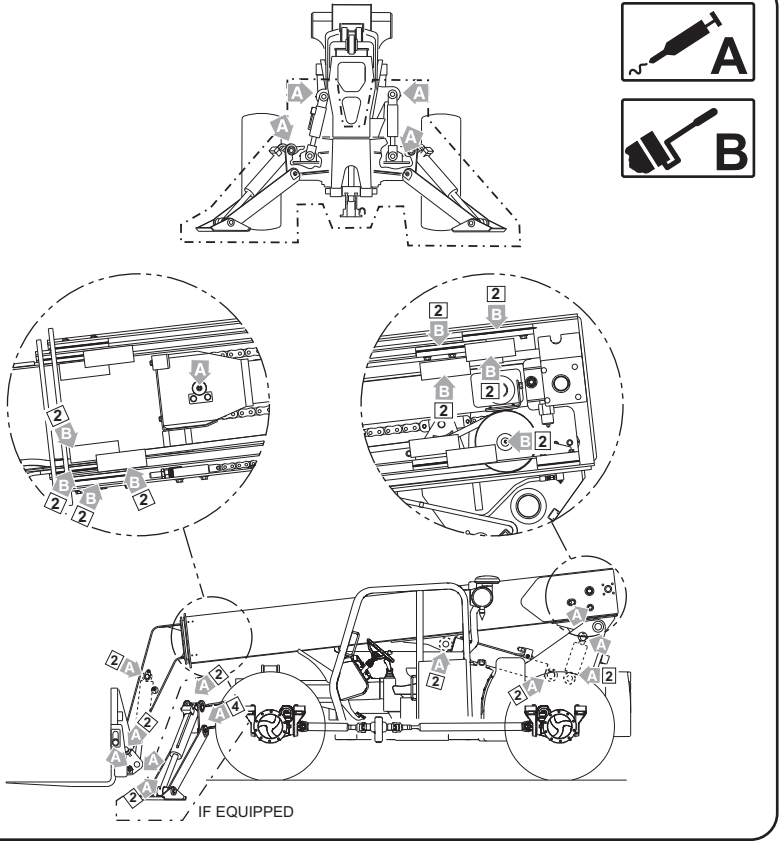

OAL0321

Section 7 - Lubrication and Maintenance

250 Hour Lubrication Schedule

EVERY
250 

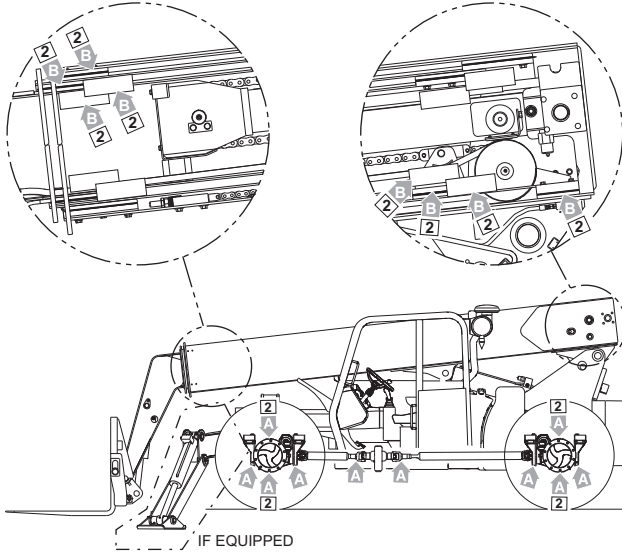

OAL0912

1000 Hour Lubrication Schedule

EVERY
1000 

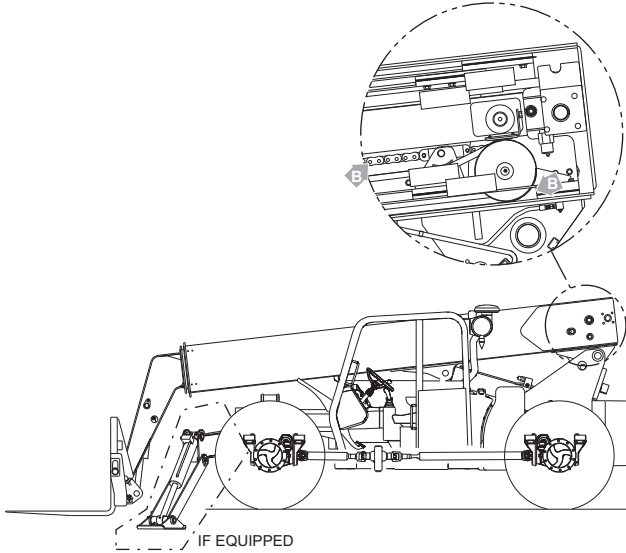

OAL2680

Section 7 - Lubrication and Maintenance

7.5 OPERATOR MAINTENANCE INSTRUCTIONS

Fuel System

A. Fuel Level Check

10 
OW0970

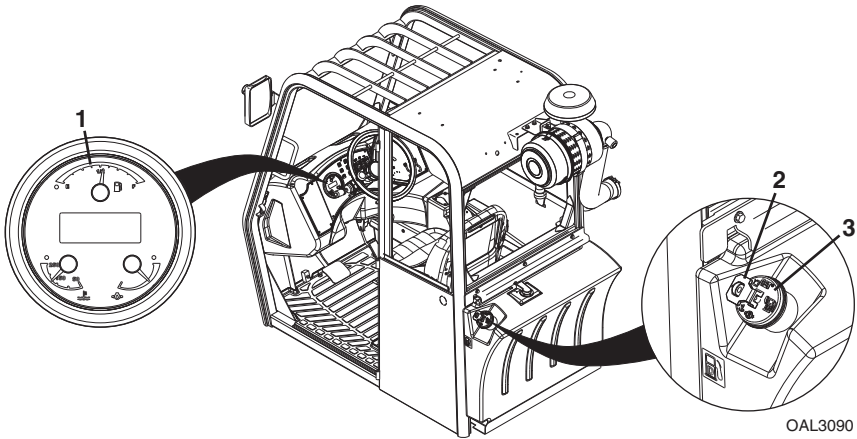

1. Check fuel gauge (1) located on instrument panel in cab.
2. If fuel is low, proceed to fuel source and perform “Shut-Down Procedure” on page 4-4.
3. If equipped, unlock and remove padlock. Lift hasp (2) and turn fuel tank cap (3) to remove from filler neck.
4. Add diesel fuel as needed.
5. Replace and secure fuel tank cap.

Note: Replenish diesel fuel at end of each work shift to minimize condensation.

NOTICE

EQUIPMENT DAMAGE. Do not allow machine to run out of fuel during operation. See Engine Operation & Maintenance Manual for details prior to servicing.

B. Fuel/Water Separator Check

50

OW0980



S/N THG00150 & AFTER
S/N THH00150 & AFTER

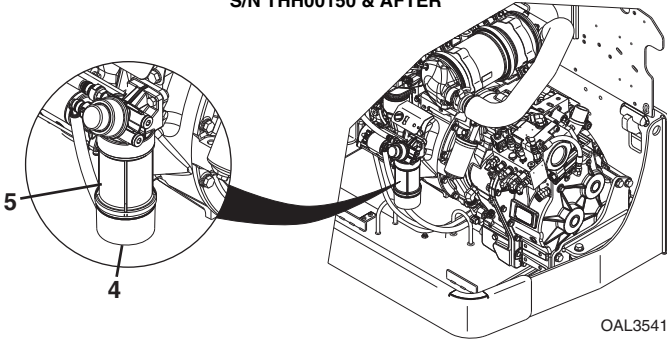

S/N THL00150 & AFTER
S/N SXH00150 & AFTER

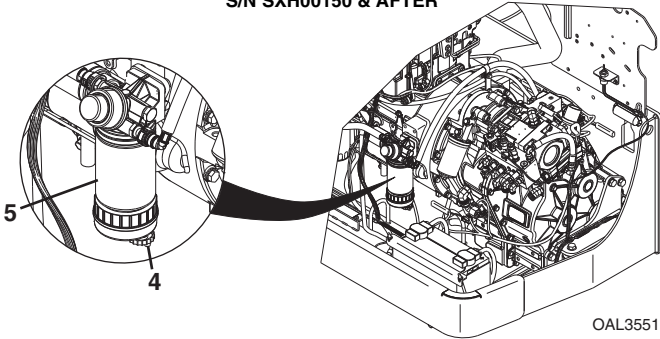

1. Perform “*Shut-Down Procedure*” on page 4-4.
2. Open the engine cover.
3. Loosen drain cock (4) on underside of fuel filter (5) and allow all water to drain into a glass until clear fuel is visible.
4. Tighten drain cock.
5. Close and secure the engine cover.

Section 7 - Lubrication and Maintenance

Air Intake System

A. Air Filter Restriction Indicator Check

10 
OW0970

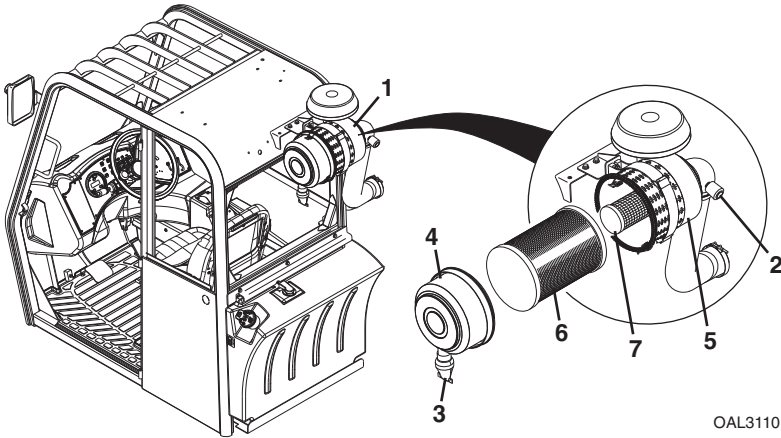

1. Perform “*Shut-Down Procedure*” on page 4-4.
2. Locate air cleaner (1) and check restriction indicator (2). If red band is visible, filter(s) must be replaced.
3. Remove dust from vacuumator valve (3) by squeezing bottom of valve to allow loose particles to fall out.

Note: Only remove canister cover to service the elements as restriction indicator indicates. Excessive access to check an element can lead to premature element failure.

Section 7 - Lubrication and Maintenance

B. Element Change (as restriction indicator indicates)

1. Perform “*Shut-Down Procedure*” on page 4-4.
2. Unlock air cleaner cover (4) and remove from air cleaner canister (5).
3. Remove outer primary element (6) and inspect for damage. Damaged elements should not be reused.
4. Thoroughly clean the interior of the air cleaner canister and vacuator valve.
5. Replace inner safety element (7) after every third primary element change. If replacing the inner safety element at this time, carefully slide the element out and replace with new element.
6. Slide the new primary element over the inner element making sure the sealing edge is flush with the base of the air cleaner.
7. Position air cleaner cover in place and lock into position.
8. Depress button on restriction indicator to reset.

Note: *An inner safety element should never be washed or reused. Always install a new element.*

Section 7 - Lubrication and Maintenance

Engine Oil

A. Engine Oil Level Check

10 
OW0970

OW1020

S/N THG00150 & AFTER
S/N THH00150 & AFTER

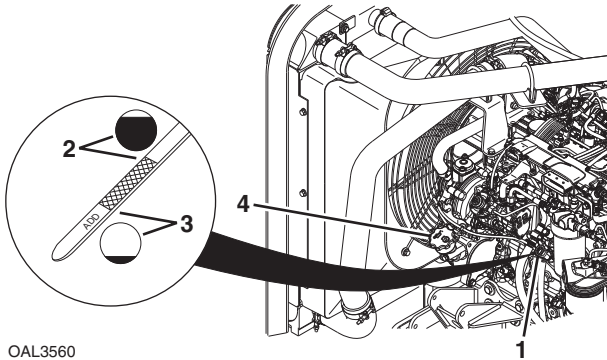

S/N THL00150 & AFTER
S/N SXH00150 & AFTER

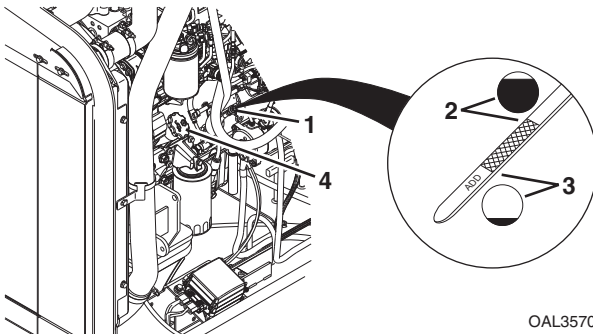

1. Perform "Shut-Down Procedure" on page 4-4.
2. Open the engine cover.
3. Remove dipstick (1) and check oil mark. The oil should be between the full (2) and add (3) marks within the crosshatched area of the dipstick.
4. If oil is low, remove oil fill cap (4) and add oil to bring oil up to the full mark in the crosshatch area.
5. Replace oil fill cap and dipstick.
6. Close and secure the engine cover.

Hydraulic Oil

A. Hydraulic Oil Level Check

10 
OW0970

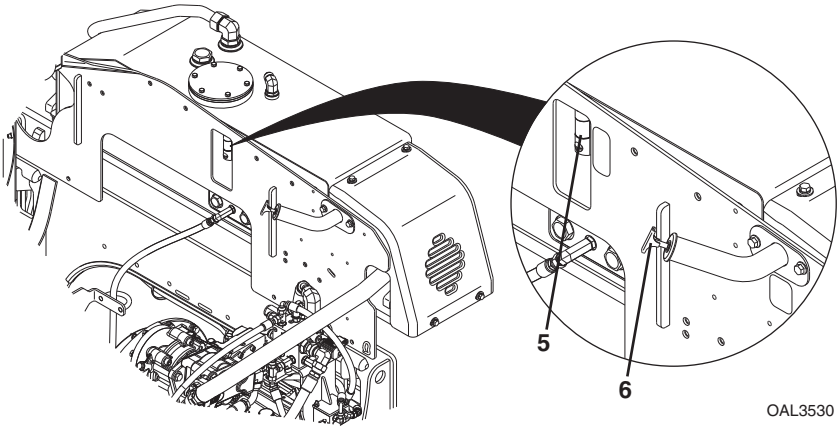

1. Be sure all cylinders are fully retracted and machine is level.
2. Perform “*Shut-Down Procedure*” on page 4-4.
3. Open the engine cover.
4. Check level of hydraulic oil at the sight gauge (5) on the hydraulic tank. The oil level should be between the marks on the sight gauge.
5. If hydraulic oil is low, remove oil fill cap (6) from filler neck. Add hydraulic oil to bring oil up between the marks on the sight gauge.
6. Replace hydraulic oil fill cap.
7. Close and secure the engine cover.

Section 7 - Lubrication and Maintenance

Tires

A. Tire Air Pressure Check



1. Perform “Shut-Down Procedure” on page 4-4.
2. Remove valve stem cap.
3. Check tire pressure.
4. Add air if required.

13.00 x 24, G-2/L-2 Bias-Ply Traction - 12 Ply	65 psi (4,5 bar)
15.50 x 25, G-2/L-2 Bias-Ply Traction - 12 Ply	58 psi (4,0 bar)
370/75-28, 14 Ply	76 psi (5,2 bar)
5. Replace valve stem cap.

B. Tire Damage

For pneumatic tires, when any cut, rip or tear is discovered that exposes sidewall or tread area cords in the tire, measures be taken to remove the product from service immediately. Arrangements must be made for replacement of the tire or tire assembly.

For polyurethane foam filled tires, when any of the following are discovered, measures must be taken to remove the product from service immediately. Arrangements must be made for replacement of the tire or tire assembly.

- a smooth even cut through the cord piles which exceeds 3 in (7,5 cm) in total length.
- any tears or rips (ragged edges) in the cord plies which exceeds 1 in (2,5 cm) in any direction
- any punctures which exceed 1 in (2,5 cm) in diameter.

If a tire is damaged but within the above noted criteria, the tire must be inspected daily to ensure the damage has not propagated beyond the allowable criteria.

Section 7 - Lubrication and Maintenance

C. Tire and Wheel Replacement

It is recommended that a replacement tire to be the same size, ply and brand as originally installed. Refer to the appropriate parts manual for ordering information. If not using an approved replacement tire, the replacement tires must have the following characteristics:

- Equal or greater ply/load rating and size of original.
- Tire tread contact width equal or greater than original.
- Wheel diameter, width and offset dimensions equal to the original.
- Approved for the application by the tire manufacturer (including inflation pressure and maximum tire load).

Unless specifically approved by JLG, do not replace a foam filled or ballast filled tire assembly with a pneumatic tire. Due to size variations between tire brands, when selecting and installing a replacement tire ensure both tires on the axle are the same.

The rims installed have been designed for stability requirements which consist of track width, tire pressure and load capacity. Size changes such as rim width, center piece location, larger or smaller diameter, etc., without written factory recommendations, may result in unsafe condition regarding stability.

Section 7 - Lubrication and Maintenance

E. Wheel Installation

Torque lug nuts after first 50 hours and after each wheel installation.

Note: If machine is equipped with directional tire assemblies, the wheel and tire assemblies must be installed with the directional tread pattern "arrows" facing in the direction of forward travel.

1. Start all nuts by hand to prevent cross threading. DO NOT use a lubricant on threads or nuts.
2. Tighten lug nuts in an alternating pattern as indicated in figure. Torque to 350-400 lb-ft (475-542 Nm).

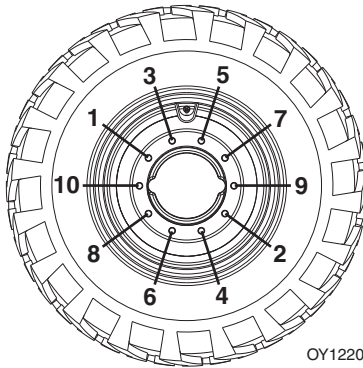

WARNING

TIP OVER HAZARD. Lug nuts must be installed and maintained at the proper torque to prevent loose wheels, broken studs and possible separation of wheel from the axle.

Transmission Oil

A. Transmission Oil Level Check

10 
OW0970

OW1050

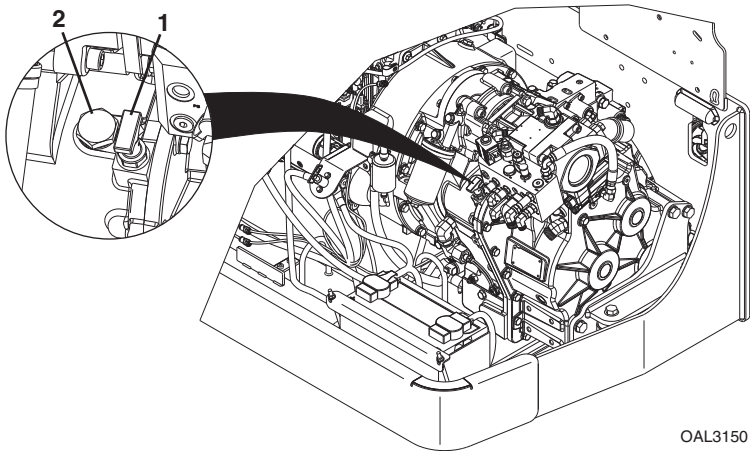

1. Check transmission oil level with engine at idle and transmission oil cold.
2. Apply park brake, shift transmission to "Neutral" and lower forks or attachment to the ground.
3. Open the engine cover.
4. Remove the transmission dipstick (1) and check oil level. The oil level should be at the MAX line.
5. Replace transmission dipstick.
6. If oil is low, remove plug (2) and add oil as required.
7. Replace plug.
8. Close and secure the engine cover.

Section 7 - Lubrication and Maintenance

Engine Cooling System

A. Engine Coolant Level Check

50 
OW0980

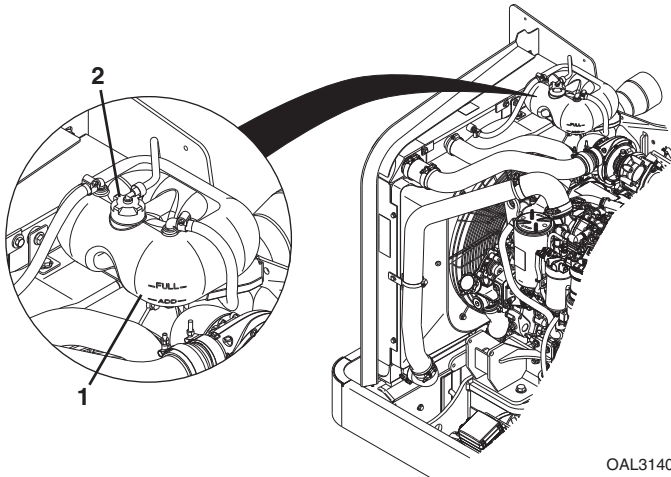

1. Perform “*Shut-Down Procedure*” on page 4-4.
2. Open the engine cover.
3. Check coolant level in surge tank (1). When coolant is hot, the tank should be 1/2 to 3/4 full. When coolant is cool, the tank should be 1/4 to 1/2 full.
4. If coolant is low, allow fluid to cool.
5. Remove surge tank cap (2) slowly. Add coolant as required.
6. Replace surge tank cap.
7. Close and secure the engine cover.

Battery

A. Battery Check

50 
OW0980

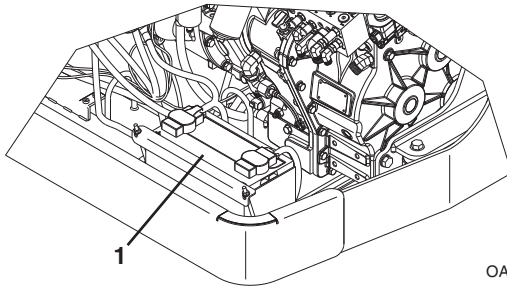
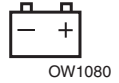

1. Perform “*Shut-Down Procedure*” on page 4-4.
2. Open the engine cover.
3. Wearing eye protection, visually inspect the battery (1). Check terminals for corrosion. Replace battery if it has a cracked, melted or damaged case.
4. Close and secure the engine cover.

Section 7 - Lubrication and Maintenance

Windshield Washer System (if equipped)

A. Windshield Washer Fluid Level Check

50 
OW0980

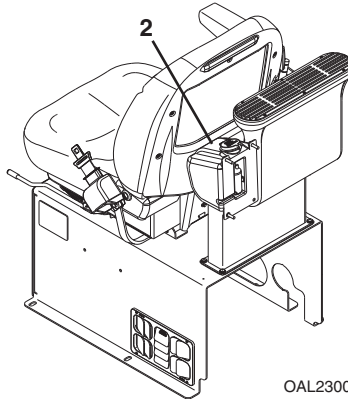

1. Perform “*Shut-Down Procedure*” on page 4-4.
2. The windshield washer fluid should be visible in the reservoir (2).
3. If washer fluid level is low, add fluid as needed.

SECTION 8 - ADDITIONAL CHECKS

8.1 GENERAL

If any of the following test results cannot be achieved, the system is not functioning properly and the machine must be removed from service and repaired before continued operation.

8.2 REVERSE SENSOR SYSTEM (IF EQUIPPED)

A. Reverse Sensor System Check

Reverse Sensor System provides audible indication of objects to rear of unit while in reverse gear.

1. Clear all people and/or obstacles behind machine before performing Reverse Sensing System check.
2. Start machine and depress and hold brake. Place machine in reverse gear.
3. Verify alarm sounds upon system start up.

Note: Reverse Sensing System detects objects of size more than 36 square inches (232.25 square centimeters) area and is functional when machine is moving in reverse direction.

Note: The use of a construction cone or similar object must be used to test the Reverse Sensing System.



WARNING

Do not use a person to test the reverse sensing system.

Section 8 - Additional Checks

4. Verify operation with no objects in detection zone. No audible alarm.
5. Verify operation when object is in range of approximately 9 to 15 ft (2.7 to 4.5 m).
Produces pulsing audible alarm at a frequency of one per second (1 Hz).
6. Verify operation when object is in range of approximately 7 to 9 ft (2.1 to 2.7 m).
Produces pulsing audible alarm. Produces pulsing audible alarm at a frequency of two per second (2 Hz).
7. Verify operation when object is range of approximately 5 to 7 ft (1.5 to 2.1 m)
Produces pulsing audible alarm at a frequency of four per second (4 Hz).
8. Verify operation when object is under approximately 5 ft (1.5 m) from machine.
Produces pulsing audible alarm at a frequency of eight per second (8 Hz).

SECTION 9 - SPECIFICATIONS

9.1 PRODUCT SPECIFICATIONS

Fluids

S/N THG00150 & After

S/N THH00150 & After

Compartment or System	Type and Classification	Viscosities	Ambient Temperature Range			
			°F		°C	
			Min	Max	Min	Max
Engine Crankcase	CAT DEO-ULS API CJ-4 Multigrade	SAE 0W-20	-40	50	-40	10
		SAE 0W-30	-40	86	-40	30
		SAE 0W-40	-40	104	-40	40
		SAE 5W-30	-22	86	-30	30
		SAE 5W-40	-22	122	-30	50
		SAE 10W-30	0	104	-18	40
		SAE 10W-40	0	122	-18	50
		SAE 15W-40	15	122	-9.5	50
Transmission and Transfer Case	CAT TDTO	SAE 0W-20	-40	95	-40	35
		SAE 10W	-4	95	-20	35
		SAE 30	77	122	25	50
		TDTO-TMS	50	122	10	50
Axle Differential* and Wheel End	CAT Synthetic Gear Oil (GO)	SAE 75W-140	-22	113	-30	45
	CAT Gear Oil (GO)	SAE 80W-90	-10	120	-23	49
	CAT Gear Oil (GO)	SAE 85W-140	10	120	-12	49
	CAT TDTO-TMS	Cat TDTO-TMS	-4	122	-20	50
Hydraulic System	CAT TDTO CAT TDTO-TMS CAT Arctic TDTO SYN commercial TO-4	SAE 0W-20	-40	104	-40	40
		SAE 0W-30	-40	104	-40	40
		SAE 5W-30	-22	104	-30	40
		SAE 5W-40	-22	104	-30	40
		SAE 10W	-4	104	-20	40
		SAE 30	50	122	10	50
		SAE 10W-30	-4	104	-20	40
		SAE 15W-40	5	122	-15	50
	Cat TDTO-TMS	-4	122	-20	50	
Boom Wear Pad Grease	CAT Advanced 3Moly	NLGI Grade 2	-4	104	-20	40

Section 9 - Specifications

Compartment or System	Type and Classification	Viscosities	Ambient Temperature Range			
			° F		° C	
			Min	Max	Min	Max
Cylinder and Axle Grease	CAT Multipurpose	NLGI Grade 2	-22	104	-30	40
Boom Chain Lubricant	Schaffer 200S Silver Streak					
Engine Coolant	CAT DEAC (Glycol and Water)	50/50 Mix	Standard			
		60/40 Mix	Cold Weather			
Fuel	#2 Diesel	Ultra Low Sulfur (S ≤ 15 mg/kg)	Standard			
	Blend of #1 diesel and #2 diesel fuels ("winterized" #2)		Cold Weather			
Air Conditioning	Refrigerant R-134-a	Tetrafluoroethane				

Note: Friction Modifier (197-0017) required for axle differential.

Section 9 - Specifications

S/N THL00150 & After
S/N SXH00150 & After

Compartment or System	Type and Classification	Viscosities	Ambient Temperature Range			
			°F		°C	
			Min	Max	Min	Max
Engine Crankcase	CAT DEO API CI-4 Multigrade	SAE 0W-20	-40	50	-40	10
		SAE 0W-30	-40	86	-40	30
		SAE 0W-40	-40	104	-40	40
		SAE 5W-30	-22	86	-30	30
		SAE 5W-40	-22	122	-30	50
		SAE 10W-30	0	104	-18	40
		SAE 10W-40	0	122	-18	50
		SAE 15W-40	15	122	-9.5	50
Transmission and Transfer Case	CAT TDTO	SAE 0W-20	-40	95	-40	35
		SAE 10W	-4	95	-20	35
		SAE 30	77	122	25	50
		TDTO-TMS	50	122	10	50
Axle Differential* and Wheel End	CAT Synthetic Gear Oil (GO)	SAE 75W-140	-22	113	-30	45
	CAT Gear Oil (GO)	SAE 80W-90	-10	120	-23	49
	CAT Gear Oil (GO)	SAE 85W-140	10	120	-12	49
	CAT TDTO-TMS	Cat TDTO-TMS	-4	122	-20	50
Hydraulic System	CAT TDTO CAT TDTO-TMS CAT Arctic TDTO SYN commercial TO-4	SAE 0W-20	-40	104	-40	40
		SAE 0W-30	-40	104	-40	40
		SAE 5W-30	-22	104	-30	40
		SAE 5W-40	-22	104	-30	40
		SAE 10W	-4	104	-20	40
		SAE 30	50	122	10	50
		SAE 10W-30	-4	104	-20	40
		SAE 15W-40	5	122	-15	50
		Cat TDTO-TMS	-4	122	-20	50
Boom Wear Pad Grease	CAT Advanced 3Moly	NLGI Grade 2	-4	104	-20	40
Cylinder and Axle Grease	CAT Multipurpose	NLGI Grade 2	-22	104	-30	40
Boom Chain Lubricant	Schaffer 200S Silver Streak					
Engine Coolant	CAT DEAC (Glycol and Water)	50/50 Mix	Standard			
		60/40 Mix	Cold Weather			

Section 9 - Specifications

Compartment or System	Type and Classification	Viscosities	Ambient Temperature Range			
			° F		° C	
			Min	Max	Min	Max
Fuel	#2 Diesel	Low Sulfur (S ≤ 500 mg/kg)	Standard			
	Blend of #1 diesel and #2 diesel fuels ("winterized" #2)		Cold Weather			
Air Conditioning	Refrigerant R-134-a	Tetrafluoroethane				

Note: Friction Modifier (197-0017) required for axle differential.

Capacities

Engine Crankcase Oil

Capacity with Filter Change9.0 qt (8,5 L)

Fuel Tank

Capacity38 gal (144 L)

Cooling System

System Capacity

THG00150 & After; THH00150 & After.....18 qt (17 L)

THL00150 & After; SXH00150 & After23 qt (22 L)

Surge Tank Capacity5 qt (4,7 L)

Hydraulic System

System Capacity

TL642C.....43 gal (163 L)

TL943C.....45 gal (170 L)

Reservoir Capacity to Middle of Sight Gauge24.5 gal (93 L)

Auxiliary Hydraulic Circuit Max Flow Not available at Publication

Transmission System

Capacity with Filter Change19.2 qt (18.2 L)

Transfer Case

Capacity2.0 qt (1,9 L)

Axles

Differential Housing Capacity

TL642C.....8.5 qt (8 L)

TL943C

Front Axle8.2 qt (7,8 L)

Rear Axle13 qt (12,3 L)

Friction Modifier (Front differential only)

TL642C.....13.6 oz (402,2 ml)

TL943C.....13.1 oz (372,7 ml)

Wheel End Capacity

TL642C.....1.3 qt (1,2 L)

TL943C.....1.8 qt (1,7 L)

Air Conditioning System (if equipped)

System Capacity2.5 lb (1134 g)

Section 9 - Specifications

Tires

Pressure

13.00 x 24, G-2/L-2 Bias-Ply Traction - 12 Ply

Pneumatic.....	65 psi (4,5 bar)
Foam.....	Approx 542 lb (246 kg)

15.50 x 25, G-2/L-2 Bias-Ply Traction - 12 Ply

Pneumatic.....	58 psi (4,0 bar)
Foam.....	Approx 600 lb (272 kg)

370/75-28, 14 Ply

Pneumatic.....	76 psi (5,2 bar)
Foam.....	Approx 464 lb (210 kg)

Wheel Lug Nut

Torque..... 350-400 lb-ft (475-542 Nm)

Performance

Note: Values shown are per machine as originally manufactured. Reference load charts in operator cab for specific model and attachment configuration values.

Maximum Lift Capacity

TL642C.....	6,500 lb (2948 kg)
TL943C.....	9,000 lb (4082 kg)

Maximum Lift Height

TL642C.....	42 ft (12,8 m)
TL943C.....	43 ft (13,1 m)

Capacity at Maximum Height

TL642C.....	6,500 lb (2948 kg)
TL943C.....	7,000 lb (3175 kg)

Maximum Forward Reach

TL642C.....	30 ft (9,1 m)
TL943C.....	31.7 ft (9,7 m)

Section 9 - Specifications

Capacity at Maximum Forward Reach

TL642C	
No Outriggers	700 lb (317 kg)
With Outriggers	
Outriggers Engaged.....	1700 lb (771 kg)
Outriggers Not Engaged	600 lb (272 kg)
TL943C	
No Outriggers	1,200 lb (544 kg)
With Outriggers	
Outriggers Engaged.....	2,700 lb (1224 kg)
Outriggers Not Engaged	1,100 lb (498 kg)

Reach at Maximum Height

TL642C.....	5 ft (1,5 m)
TL943C.....	6.4 ft (2 m)

Maximum Travel Speed

TL642C	
THG00150 & After	19.7 mph (31,7 kph)
THL00150 & After.....	22.0 mph (35,4 kph)
TL943C	
THH00150 & After	20.3 mph (32,7 kph)
SXH00150 & After	21.2 mph (34,1 kph)

Towing Capacity

TL642C.....	6,500 lb (2948 kg)
TL943C.....	9,000 lb (4082 kg)

Frame Leveling..... 10 degrees

Maximum Travel Grade (boom in travel position)

Gradeability	24 degrees (45%)
Side Slope	5 degrees (8.75%)

Section 9 - Specifications

Dimensions

Overall Height

TL642C	95.4 in (2423 mm)
TL943C	95.5 in (2426 mm)

Overall Width

TL642C	99 in (2515 mm)
TL943C	95.3 in (2421 mm)

Cab Width.....37 in (940 mm)

Track Width82.2 in (2089 mm)

Wheelbase

TL642C	128 in (3251 mm)
TL943C	132 in (3352 mm)

Length at Front Wheels

TL642C	168 in (4267 mm)
TL943C	180 in (4572 mm)

Overall Length (less Attachment)

TL642C	212.6 in (5400 mm)
TL943C	237.5 in (6033 mm)

Ground Clearance (Axle Center) 17 in (432 mm)

Turning Radius Over Tires

TL642C	141.3 in (3588 mm)
TL943C	144 in (3658 mm)

Turning Radius at Forks

TL642C	182.4 in (4633 mm)
TL943C	204.6 in (5197 mm)

Maximum Operating Weight (no attachment)

TL642C

No Outriggers.....	21,360 lb (9.689 kg)
With Outriggers	23,750 lb (10.773 kg)

TL943C

No Outriggers.....	28,410 lb (12.887 kg)
With Outriggers	29,210 lb (13.249 kg)

Section 9 - Specifications

Maximum Front Axle Weight (no attachment, boom level and fully retracted)

TL642C

No Outriggers	10,785 lb (4.892 kg)
With Outriggers.....	12,230 lb (5.547 kg)

TL943C

No Outriggers	13,319 lb (6.041 kg)
With Outriggers.....	14,645 lb (6.643 kg)

Maximum Rear Axle Weight (no attachment, boom level and fully retracted)

TL642C

No Outriggers	14,085 lb (6.389 kg)
With Outriggers.....	12,660 lb (5.743 kg)

TL943C

No Outriggers	16,190 lb (7.344 kg)
With Outriggers.....	15,660 lb (7.103 kg)

Maximum Ground Bearing Pressure

TL642C

13.00 x 24 Foam Filled

No Outriggers.....	180 lbs/in ² (12,66 kg/cm ²)
With Outriggers	187 lbs/in ² (13,15 kg/cm ²)

15.50 x 25 Foam Filled

No Outriggers.....	182 lbs/in ² (12,80 kg/cm ²)
With Outriggers	190 lbs/in ² (13,36 kg/cm ²)

370/75-28 Foam Filled

No Outriggers.....	116 lbs/in ² (8,15 kg/cm ²)
With Outriggers	117 lbs/in ² (8,23 kg/cm ²)

TL943C

13.00 x 24 Foam Filled

No Outriggers.....	188 lbs/in ² (13,22 kg/cm ²)
With Outriggers	191 lbs/in ² (13,43 kg/cm ²)

15.50 x 25 Foam Filled

No Outriggers.....	185 lbs/in ² (13,01 kg/cm ²)
With Outriggers	189 lbs/in ² (13,29 kg/cm ²)

370/75-28 Foam Filled

No Outriggers.....	122 lbs/in ² (8,58 kg/cm ²)
With Outriggers	123 lbs/in ² (8,65 kg/cm ²)

This Page Intentionally Left Blank

A	C
Accessory Control Lever 3-18	Capacities
Additional Checks..... 8-1	Air Conditioning System9-5
Adjusting/Moving Forks 5-13	Axles.....9-5
After-Treatment System 4-6	Cooling System9-5
Air Conditioning	Engine Oil9-5
Controls..... 3-17	Fuel Tank.....9-5
Attachment Installation	Hydraulic System.....9-5
Hydraulic Quick Coupler 5-11	Transfer Case.....9-5
Mechanical Quick Coupler 5-10	Transmission9-5
Attachments	Capacity5-4
Approved..... 5-1	Capacity Indicator Locations.....5-5
JLG Supplied 5-2	Carriage with Forks..... 5-16
Operation 5-14	Chemical Hazards..... 1-13
Unapproved 5-1	Controls.....3-2
Automatic Regeneration..... 4-6	Coolant Level7-20
Auxiliary Hydraulic Joystick 3-15	Coupler Mounted Hook5-34
B	D
Battery 7-21	Dash Controls and Indicators.....3-4
Boom Head-Mounted Winch 5-40	Decals
Boom Indicator	ANSI2-4
Angle..... 3-23	ISO2-7
Extension 3-23	Dimensions9-8
Boom Joystick 3-10, 3-12	Disengaging a Load 4-10
Bucket 5-28	Disengaging a Suspended Load..... 4-13
	Driving Hazards on Slopes 1-9
	Dual Fork Positioning Carriage 5-24
	E
	Electrical Hazards 1-2
	Emergency Exit from Enclosed Cab .6-2
	Emergency Lowering of Boom.....6-2
	Emergency Procedures6-1
	Engine
	Extreme Cold Weather Starting...4-2
	Normal Operation4-4
	Starting4-1
	Engine Oil Level.....7-14

Index

F

Fall Hazard	1-12
Fluids	9-1
Fork Extension.....	5-26
Fork Mounted Hook.....	5-32
Frame Level Joystick.....	3-14
Fuel Level.....	7-10
Fuel/Water Separator	7-11

G

General Maintenance	7-2
---------------------------	-----

H

Hazard Classification System.....	1-1
Headlights.....	3-18
Heater Controls	3-17
Hydraulic Oil Level.....	7-15
Hydraulic Operated Attachment	5-12

I

Ignition.....	3-6
---------------	-----

L

Leveling Procedure.....	4-9, 4-12
Lifting Personnel.....	1-8
Load Chart	
Example	5-8
Sample.....	5-6
Load Falling Hazard	1-7
Lubrication and Maintenance	7-1
Lubrication Schedule	
1000 Hour	7-9
250 Hour	7-8
50 Hour	7-7

M

Manual Regeneration	4-7
Material Handling Arm.....	5-38
Multi-Purpose Bucket	5-30

O

Operating with a Non-Suspended Load	4-8
Operating with a Suspended Load	4-11
Operational Check	2-12
Operator Cab	2-13
Operator Maintenance Instructions.....	7-10
Operator Seat.....	3-20
Outrigger Joysticks.....	3-16

P

Park Brake	3-7
Parking Lights	3-18
Parking Procedure	3-7
Performance.....	9-6
Personnel Work Platform - Fork Mounted	5-36
Picking Up a Load.....	4-8
Picking Up a Suspended Load.....	4-11
Pinch Points and Crush Hazards	1-10
Placing a Load	4-10
Placing a Suspended Load	4-13
Pre-Operation Check and Inspection.....	2-1

R

Restriction Indicator	7-12
Right Hand Panel	3-17
Rotate/Side Tilt Carriage.....	5-20

S

Safety Decals	2-3
Safety Practices	1-1
Safety Signal Words.....	1-1
Seat Belt.....	3-21
Service and Maintenance Schedule	
10 Hour	7-3
1000 Hour	7-5
1500 Hour	7-5
1st 250 Hour	7-4
1st 50 Hour	7-3
1st 500 Hour	7-4
250 Hour	7-4
3000 Hour	7-6
50 Hour	7-3
500 Hour	7-5
Shut-Down Procedure.....	4-4
Side Shift Carriage	5-18
Specifications	9-1
Steer Modes	3-19
Swing Carriage.....	5-22

T

Tip Over Hazard	1-3
Tires	7-16, 9-6
Air Pressure	7-16
Damage	7-16
Replacement.....	7-17
Towing.....	6-1
Transmission Control Lever	
Direction of Travel.....	3-8
Gear Selection	3-9
Transmission Oil Level.....	7-19
Transport	
Lifting	4-15
Tiedown	4-14
Transporting a Load	4-9
Transporting a Suspended Load ...	4-12
Travel Hazard.....	1-6
Truss Boom.....	5-35
Turn Signal.....	3-18

W

Walk-Around Inspection.....	2-10
Warm-Up Check	2-12
Wheel Installation.....	7-18
Wheel Lug Nut	9-6
Wheel Replacement.....	7-17
Windows	2-14
Windshield Washer Fluid Level.....	7-22



An Oshkosh Corporation Company

TRANSFER OF OWNERSHIP

To Product Owner:

If you now own but ARE NOT the original purchaser of the product covered by this manual, we would like to know who you are. For the purpose of receiving safety-related bulletins, it is very important to keep JLG Industries, Inc. updated with the current ownership of all JLG products. JLG maintains owner information for each JLG product and uses this information in cases where owner notification is necessary.

Please use this form to provide JLG with updated information with regard to the current ownership of JLG products. Please return completed form to the JLG Product Safety & Reliability Department via facsimile or mail to address as specified below.

Thank You,
Product Safety & Reliability Department
JLG Industries, Inc.
13224 Fountainhead Plaza
Hagerstown, MD 21742
USA
Telephone: +1-717-485-6591
Fax: +1-301-745-3713

NOTE: Leased or rented units should not be included on this form.

Mfg. Model: _____

Serial Number: _____

Previous Owner: _____

Address: _____

Country: _____ **Telephone:** (_____) _____

Date of Transfer: _____

Current Owner: _____

Address: _____





Country: _____ **Telephone:** (_____) _____

Who in your organization should we notify?

Name: _____

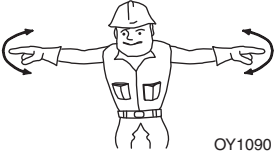
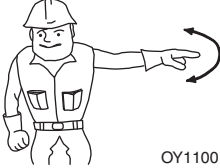
Title: _____

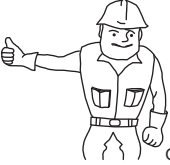
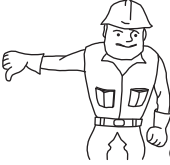
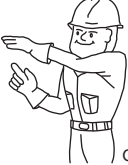
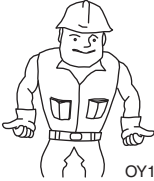
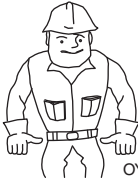
Hand Signals

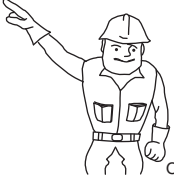
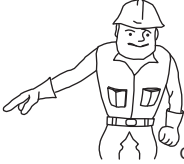
 <p>OY1090</p> <p>EMERGENCY STOP - With both arms extended laterally, hands open downward, move arms back and forth.</p>	 <p>OY1100</p> <p>STOP - With either arm extended laterally, hand open downward, move arm back and forth.</p>	 <p>OY1110</p> <p>STOP ENGINE - Draw thumb or forefinger across throat.</p>
 <p>OY1120</p> <p>RAISE BOOM - With either arm extended horizontally, fingers closed, point thumb upward.</p>	 <p>OY1130</p> <p>LOWER BOOM - With either arm extended horizontally, fingers closed, point thumb downward.</p>	 <p>OY1140</p> <p>MOVE SLOWLY - Place one hand motionless in front of hand giving motion signal. (Raise load slowly shown)</p>
 <p>OY1150</p> <p>EXTEND BOOM - With both hands clenched, point thumbs outward.</p>	 <p>OY1160</p> <p>RETRACT BOOM - With both hands clenched, point thumbs inward.</p>	 <p>OY1170</p> <p>THIS FAR TO GO - With hands raised and open inward, move hands laterally, indicating distance to go.</p>
 <p>OY1180</p> <p>TILT FORKS UP - With one arm held at side, extend other arm upward at about 45 degrees.</p>	 <p>OY1190</p> <p>TILT FORKS DOWN - With one arm held at side, extend other arm downward at about 45 degrees.</p>	

Special Signals - When signals for auxiliary equipment functions or conditions not covered are required, they shall be agreed upon in advance by the operator and signalman.



31200747

CATERPILLAR®